



Automotive Thin Film Chip Resistors
RBA series Standard
(Halogen -Free)
AEC-Q200 compliant

Document No

TRBA-XX0S001B

Issued date

2020/11/11

page

1/13

1. Scope:

This specification applies for the RBA series of automotive thin film chip resistors made by TA-I.

2. Construction:

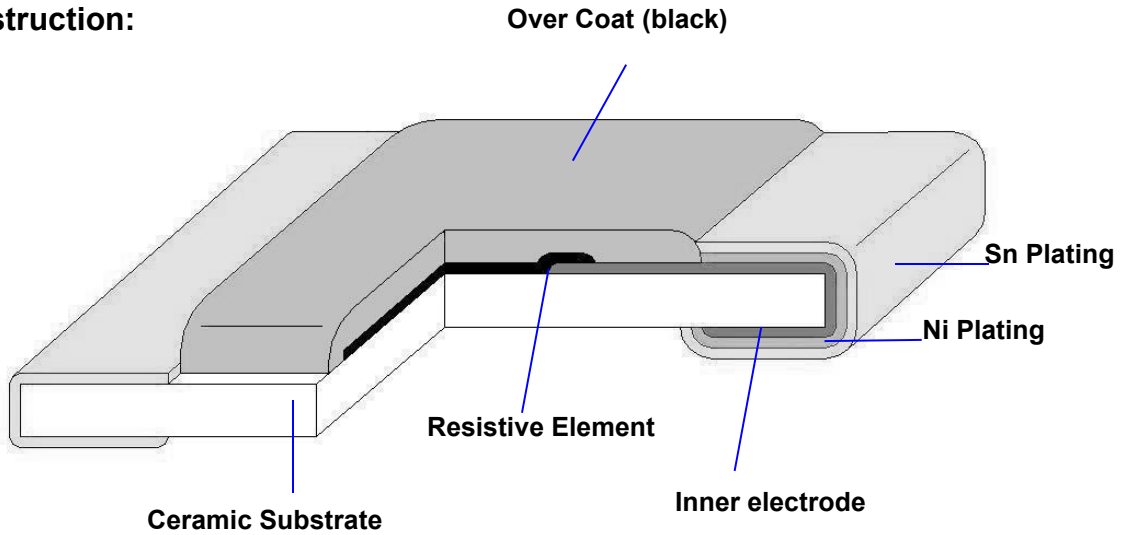

3. Type Designation:

RBA

06

B

T

P

1001

Product Code

Size

Tolerance

Packaging

TCR

Nominal

RBA : Automotive

Power Rating

Resistance

04-0402(1005) 1/16W	B - $\pm 0.10\%$	T- Paper	k- ± 10 ppm	e.g., 1001=1k Ω
06-0603(1608) 1/10W	C - $\pm 0.25\%$	Tape	M- ± 15 ppm	
10-0805(2012) 1/8W	D - $\pm 0.50\%$		P- ± 25 ppm	
12-1206(3216) 1/4W	F - $\pm 1.00\%$		S- ± 50 ppm	



Automotive Thin Film Chip Resistors
RBA series Standard
 (Halogen -Free)
 AEC-Q200 compliant

Document No

TRBA-XX0S001B

Issued date

2020/11/11

page

2/13

4. Dimensions:

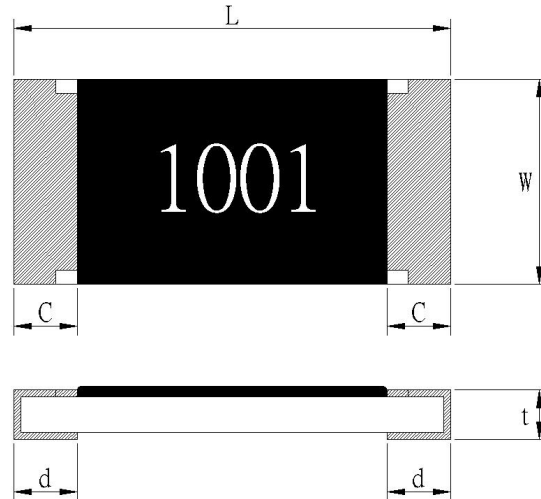

UNIT: mm

Type	L	W	C	d	t
RBA04	1.00± 0.05	0.50 ±0.05	0.20 ±0.10	0.25 ±0.10	0.35 ±0.05
RBA06	1.60 ±0.10	0.80 ±0.10	0.30 ±0.20	0.30 + 0.20 - 0.10	0.45 ±0.10
RBA10	2.00 ±0.10	1.25 ±0.10	0.40 ±0.20	0.40 ±0.20	0.50 ±0.10
RBA12	3.20 ±0.15	1.60 ±0.15	0.50 ±0.30	0.40 ±0.20	0.55 ±0.10



Automotive Thin Film Chip Resistors
RBA series Standard
(Halogen -Free)
AEC-Q200 compliant

Document No

TRBA-XX0S001B

Issued date

2020/11/11

page

3/13

5-1. Standard Ratings & Characteristics

Type	Power Rating at 70°C	Rated Voltage	Max. Working Voltage	Max. Over- Load Voltage	T.C.R (PPM/°C)	Resistance Range	Resistance tolerance(%)
RBA04	1/16 W	Refer 5.2	50V	100V	±10 ±15 ±25 ±50	10Ω~100KΩ	± 0.1~ ±1.0
RBA06	1/10 W	Refer 5.2	75V	150V	±10 ±15 ±25 ±50	10Ω~511KΩ	± 0.1~ ±1.0
RBA10	1/8 W	Refer 5.2	150V	300V	±10 ±15 ±25 ±50	10Ω~800KΩ	± 0.1~ ±1.0
RBA12	1/4 W	Refer 5.2	200V	400V	±10 ±15 ±25 ±50	10Ω~1MΩ	± 0.1~ ±1.0

Operating Temp(°C): -55°C ~ +155°C

Note : Except for the above standardized products, we also provide the customized products.



5.1 Derating Curve :

For resistors operated at ambient temperature over 70°C, power rating shall be derated according to figure 1.

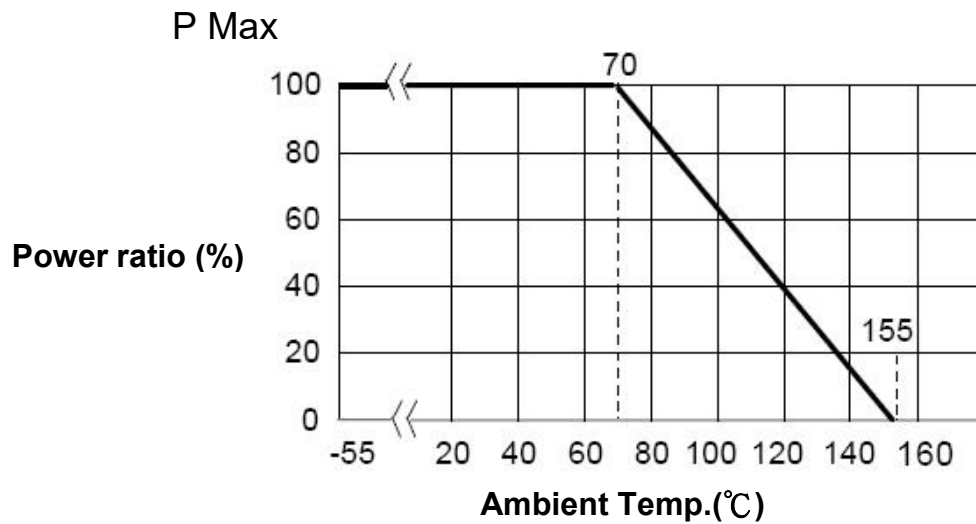

Figure 1.

5.2 Rated Voltage:

The rated voltage is calculated by the following formula:

$$E = \sqrt{P * R}$$

E=Rated Voltage(V)

P=Rated Power(W)

R=Resistance Value(Ω)



**Automotive Thin Film Chip Resistors
RBA series Standard
(Halogen –Free)
AEC-Q200 compliant**

Document No

TRBA-XX0S001B

Issued date

2020/11/11

page

5/13

6. Reliability Tests:

Test Items	Reference standard	Condition of Test	Test Limits
Flowers of sulfur corrosion (FoS)	ASTM-B-809-95* *Modified	Sulfur 1000 hours, 105°C Unpower	±(1%+0.05Ω)
Temperature Coefficient of Resistance	IEC60115-1-4.8 JIS C5201-1-4.8	+25 to +125 °C	Refer 5.0
Short Time Overload	IEC60115-1-4.13 JIS C5201-1-4.13	2.5 X rated voltage for 5sec	tol. ≤0.05% : ±0.5% tol. >0.05% : ±0.2%
High Temperature Exposure (Storage)	AEC-Q200-REV D-Test 3 MIL-STD-202 Method 108	1000 hrs. @ T=125°C. Unpowered. 1000 hrs. @ T=155°C. Unpowered.	±(0.1%+0.05Ω) ±(0.2%+0.05Ω)
Temperature Cycling	JESD22 Method JA-104	-55°C(30 min.) / +125°C(30 min.), 1000 cycles. 1 min. maximum transition time.	±(0.1%+0.05Ω)
Moisture Resistance	AEC-Q200-REV D-Test 6 MIL-STD-202 Method 106	T=24 hours / Cycle, 10 Cycles. Unpowered.	±(0.1%+0.05Ω)
Biased Humidity	MIL-STD-202 Method 103	1000 hours 85°C/85%RH. 10% Rated Power.	±(0.1%+0.05Ω)
Operational Life	MIL-STD-202 Method 108	1000 hrs. @ T=70°C. rated power 1000 hrs. @ T=125°C. 35% rated power	±(0.1%+0.05Ω) ±(0.3%+0.05Ω)
Resistance to Solvent	AEC-Q200-REV D-Test 12 MIL-STD-202 Method 215	a:Isopropyl Alcohol : Mineral Spirits= 1 : 3 b:Terpene Defluxer (Bioact EC-7R) c:Deionized water : Propylene Glycol Monomethyl Ether : monoethanolamine =42 : 1 : 1	Marking and protective layer can't be detached
Mechanical Shock	AEC-Q200-REV D-Test 13 MIL-STD-202 Method 213	Wave Form : Tolerance for half sine shock pulse. Peak value is 100g's. Normal duration(D) is 6(ms)	±(0.1% +0.05Ω)
Vibration	AEC-Q200-REV D-Test 14 MIL-STD-202 Method 204	5 g's for 20 min., 12 cycles each of 3 orientations. Note: Test from 10-2000 Hz.	±(0.1% +0.05Ω)
Resistance to Solder Heat	AEC-Q200-REV D-Test 15 MIL-STD-202 Method 210	260 ±5°C solder, 10 ±1 sec dwell.	±(0.05% +0.05Ω)
Thermal Shock	AEC-Q200-REV D-Test 16 MIL-STD-202 Method 107	-55°C(15min)/+155°C(15min), 1000 cycles. Maximum transfer time-20 seconds, Air-Air.	±(0.1% +0.05Ω)
ESD	AEC-Q200-REV D-Test 17	Human body model 04/06: 200V 10/12: 1kV	±(0.5% +0.05Ω)
Solderability	IEC60115-1-4.17 JIS C5201-1-4.17	245 ±5°C solder, 2 ±0.5 sec dwell. Solder : Sn96.5 / Ag3.0 / Cu0.5	At least 95% of surface area of electrode shall be covered with new solder.
Flammability	AEC-Q200-REV D-Test 20 UL-94	V-0 or V-1 are acceptable. Electrical test not required.	V-0 or V-1
Board Flex (Bending)	AEC- Q200-005	3mm deflection	±(0.1% +0.05Ω)
Terminal Strength (SMD)	AEC-Q200-REV D-Test 22	04: 1.0kg for 60 seconds 06/10/12: 1.8kg for 60 seconds	No broken

Note* :RCWV : Rated continuous working voltage .

MSL : Moisture Sensitivity Level .



**Automotive Thin Film Chip Resistors
RBA series Standard
(Halogen –Free)
AEC-Q200 compliant**

Document No

TRBA-XX0S001B

Issued date

2020/11/11

page

6/13

7. Marking

7.1 ±0.1% , ±0.5% , ±1% (E96) : RBA10 / RBA12

Resistance value is expressed by 4 digits , the first three digits represent the significant figures of nominal resistance value in Ω , and the fourth digit represents exponent for base of 10.

E.G. : 1000 = $100 \times 10^0 = 100 \Omega$

7.2 ±0.1% , ±0.5% , ±1% (RBA06/E96)

When the marking space is too small in such small-sized resistors as RBA06, the marking can not made by 4 digits and may be made by two digits combined with one English capital.

Symbol for E96 series nominal resistance value

Symbol	E96	Symbol	E96	Symbol	E96	Symbol	E96
01	100	25	178	49	316	73	562
02	102	26	182	50	324	74	576
03	105	27	187	51	332	75	590
04	107	28	191	52	340	76	604
05	110	29	196	53	348	77	619
06	113	30	200	54	357	78	634
07	115	31	205	55	365	79	649
08	118	32	210	56	374	80	665
09	121	33	215	57	383	81	681
10	124	34	221	58	392	82	698
11	127	35	226	59	402	83	715
12	130	36	232	60	412	84	732
13	133	37	237	61	422	85	750
14	137	38	243	62	432	86	768
15	140	39	249	63	442	87	787
16	143	40	255	64	453	88	806
17	147	41	261	65	464	89	825
18	150	42	267	66	475	90	845
19	154	43	274	67	487	91	866
20	158	44	280	68	499	92	887
21	162	45	287	69	511	93	909
22	165	46	294	70	523	94	931
23	169	47	301	71	536	95	953
24	174	48	309	72	549	96	976

Symbol for multipliers

Symbol	A	B	C	D	E	F	G	H	X	Y	Z
multipliers	10^0	10^1	10^2	10^3	10^4	10^5	10^6	10^7	10^{-1}	10^{-2}	10^{-3}

Ex: 02c=102 $\times 10^2=10.2k\Omega$



**Automotive Thin Film Chip Resistors
RBA series Standard
(Halogen –Free)
AEC-Q200 compliant**

Document No

TRBA-XX0S001B

Issued date

2020/11/11

page

7/13

7.3 ±0.1% , ±0.5% , ±1% (RBA06/E24)

When the resistance value is not in the list of E96 , 3 digitals with underline in E-24 series is used as mark .

Symbol	E24	Marking	Symbol	E24	Marking	Symbol	E24	Marking
1	12R	<u>120</u>	31	510R	<u>511</u>	61	30K	<u>303</u>
2	16R	<u>160</u>	32	560R	<u>561</u>	62	33K	<u>333</u>
3	18R	<u>180</u>	33	620R	<u>621</u>	63	36K	<u>363</u>
4	22R	<u>220</u>	34	680R	<u>681</u>	64	39K	<u>393</u>
5	24R	<u>240</u>	35	820R	<u>821</u>	65	43K	<u>433</u>
6	27R	<u>270</u>	36	910R	<u>911</u>	66	47K	<u>473</u>
7	30R	<u>300</u>	37	1K2	<u>122</u>	67	51K	<u>513</u>
8	33R	<u>330</u>	38	1K6	<u>162</u>	68	56K	<u>563</u>
9	36R	<u>360</u>	39	1K8	<u>182</u>	69	62K	<u>623</u>
10	39R	<u>390</u>	40	2K2	<u>222</u>	70	68K	<u>683</u>
11	43R	<u>430</u>	41	2K4	<u>242</u>	71	82K	<u>823</u>
12	47R	<u>470</u>	42	2K7	<u>272</u>	72	91K	<u>913</u>
13	51R	<u>510</u>	43	3K0	<u>302</u>	73	120K	<u>124</u>
14	56R	<u>560</u>	44	3K3	<u>332</u>	74	160K	<u>164</u>
15	62R	<u>620</u>	45	3K6	<u>362</u>	75	180K	<u>184</u>
16	68R	<u>680</u>	46	3K9	<u>392</u>	76	220K	<u>224</u>
17	82R	<u>820</u>	47	4K3	<u>432</u>	77	240K	<u>244</u>
18	91R	<u>910</u>	48	4K7	<u>472</u>	78	270K	<u>274</u>
19	120R	<u>121</u>	49	5K1	<u>512</u>	79	300K	<u>304</u>
20	160R	<u>161</u>	50	5K6	<u>562</u>	80	330K	<u>334</u>
21	180R	<u>181</u>	51	6K2	<u>622</u>	81	360K	<u>364</u>
22	220R	<u>221</u>	52	6K8	<u>682</u>	82	390K	<u>394</u>
23	240R	<u>241</u>	53	8K2	<u>822</u>	83	430K	<u>434</u>
24	270R	<u>271</u>	54	9K1	<u>912</u>	84	470K	<u>474</u>
25	300R	<u>301</u>	55	12K	<u>123</u>	85	510K	<u>514</u>
26	330R	<u>331</u>	56	16K	<u>163</u>	86	560K	<u>564</u>
27	360R	<u>361</u>	57	18K	<u>183</u>	87	620K	<u>624</u>
28	390R	<u>391</u>	58	22K	<u>223</u>	88	680K	<u>684</u>
29	430R	<u>431</u>	59	24K	<u>243</u>	89	820K	<u>824</u>
30	470R	<u>471</u>	60	27K	<u>273</u>	90	910K	<u>914</u>



Automotive Thin Film Chip Resistors
RBA series Standard
 (Halogen -Free)
 AEC-Q200 compliant

Document No

TRBA-XX0S001B

Issued date

2020/11/11

page

8/13

Ex.: 0603 , 120Ω , 0.1% Marking is 121



7.4 ±0.1% , ±0.5% , ±1%(E96/3digitals)

The resistance value by 3 digits is requirement for customer.

7.5 No Marking for RBA04

8. Taping & Reel

8.1 Taping Dimensions

8.1.1 4 mm pitch paper

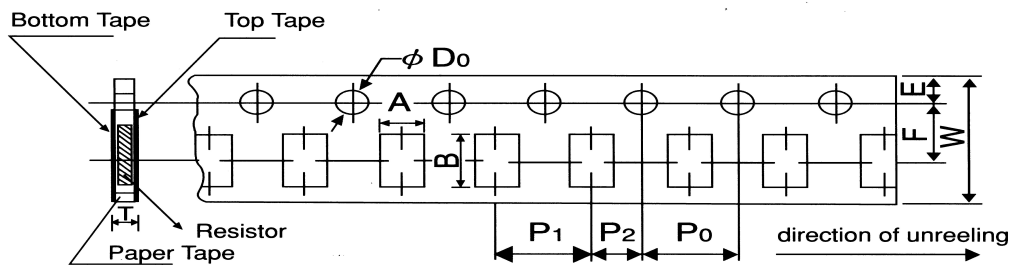

Packing	Type	A	B	W	F	E	P ₁	P ₂	P ₀	D ₀	T
Paper Tape	RBA06	1.1±0.1	1.9±0.1								0.64±0.1
	RBA10	1.6±0.15	2.4±0.2	8.0±0.2	3.5±0.05	1.75±0.1	4.0±0.1	2.0±0.1	4.0±0.1	Φ _{1.5} ^{+0.1} ₋₀	0.84±0.1
	RBA12	2.0±0.15	3.6±0.2								

UNIT: mm



Automotive Thin Film Chip Resistors
RBA series Standard
 (Halogen -Free)
 AEC-Q200 compliant

Document No

TRBA-XX0S001B

Issued date

2020/11/11

page

9/13

8.1.2 2 mm pitch paper

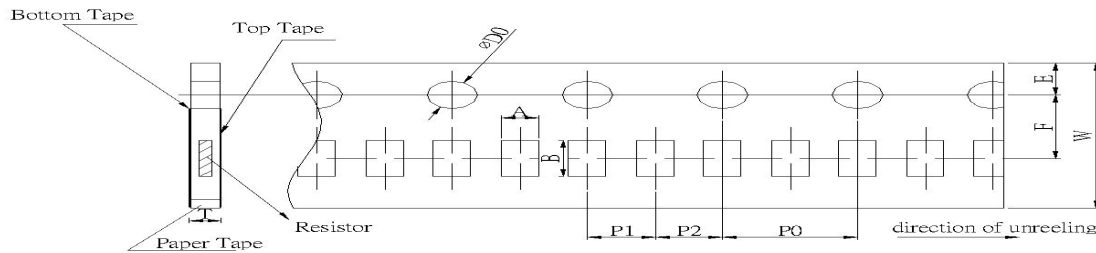

Packing	Type	A	B	W	F	E	P ₁	P ₂	P ₀	D ₀	T
Paper Tape	RBA04	0.7±0.05	1.2±0.05	8.0±0.2	3.5±0.05	1.75±0.1	2.0±0.1	2.0±0.1	4.0±0.1	Φ _{1.5} ^{+0.1} ₋₀	0.45±0.1

UNIT: mm

Type		Paper Tape	
		4 mm pitch	2 mm pitch
		180mm/R	180mm/R
RBA	04	NA	10000
RBA	06	5000	NA
RBA	10	5000	NA
RBA	12	5000	NA



Automotive Thin Film Chip Resistors
RBA series Standard
 (Halogen -Free)
 AEC-Q200 compliant

Document No

TRBA-XX0S001B

Issued date

2020/11/11

page

10/13

8.2 Reel Specifications

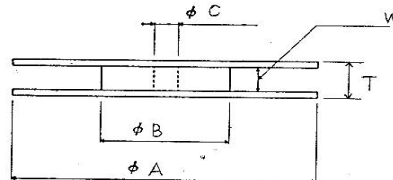
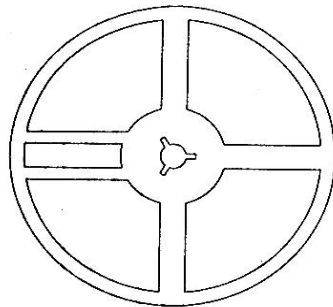

Type	ΦA	ΦB	ΦC	W	T
RBA 04/06/10/12	178.0 ±2.0	60.0 ±1.0	13.0 ±1.0	9.0 ±1.0	11.4 ±1.0

UNIT: mm

8.3 Peel – off force:

Peel – off force of paper and blister tape is in accordance with “JIS ”
 that is , 0.1 to 0.7 N at a peel-off speed of 300 mm / minute.

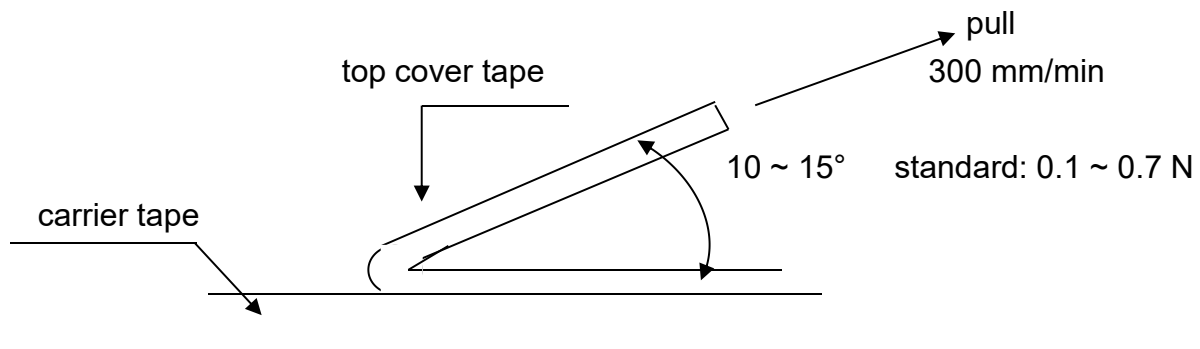

UNIT:mm



Automotive Thin Film Chip Resistors
RBA series Standard
(Halogen -Free)
AEC-Q200 compliant

Document No

TRBA-XX0S001B

Issued date

2020/11/11

page

11/13

9. Label

10.1 Normal Products :

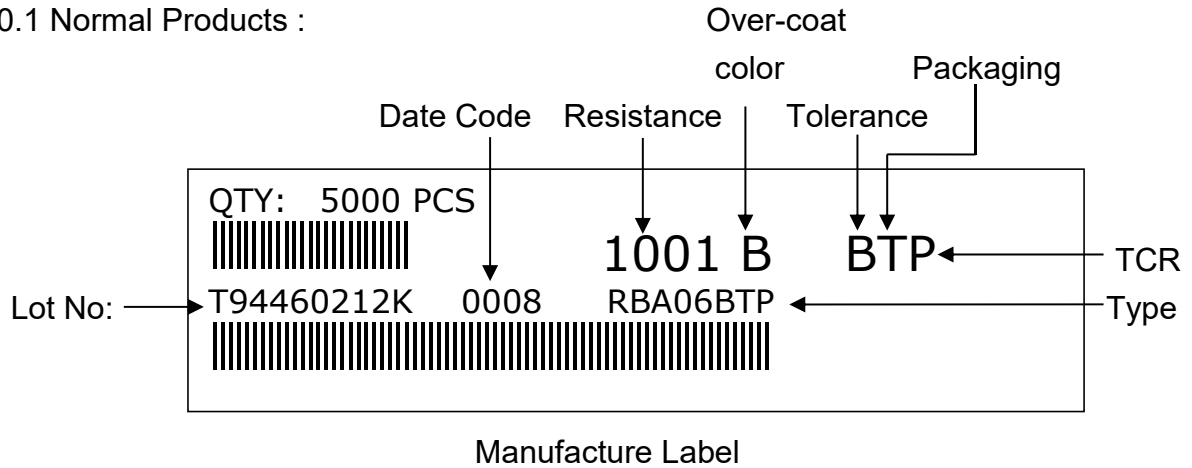

10. Recommended land patterns

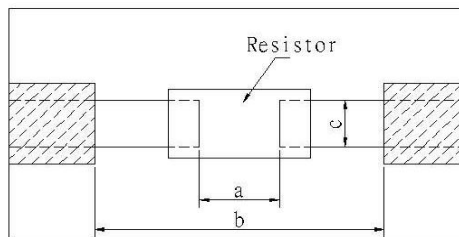

Type	Size	Land pattern		
		Dimension (mm)		
		a	b	c
RBA	04 (0402)	0.5 ~ 0.6	1.4 ~ 1.6	0.5~ 0.6
RBA	06 (0603)	0.7 ~ 0.9	2.0 ~ 2.2	0.9 ~1.0
RBA	10 (0805)	1.0 ~ 1.4	3.2 ~ 3.8	1.3 ~1.4
RBA	12 (1206)	2.0 ~ 2.4	4.4 ~ 5.0	1.6 ~1.8

11. ECN

Engineering Change Notice: The customer will be informed with ECN if there is significant modification on the characteristics and materials described in Approval Sheet.

12. Storage Conditions:

Temperature: 5°C~35°C, Humidity:40%~75%

13. Shelf Life:

2 years from manufacturing date.



Automotive Thin Film Chip Resistors
RBA series Standard
 (Halogen -Free)
 AEC-Q200 compliant

Document No	TRBA-XX0S001B
Issued date	2020/11/11
page	12/13

14. Recommend IR – Reflow profile: (solder: Sn96.5 / Ag3 / Cu0.5)

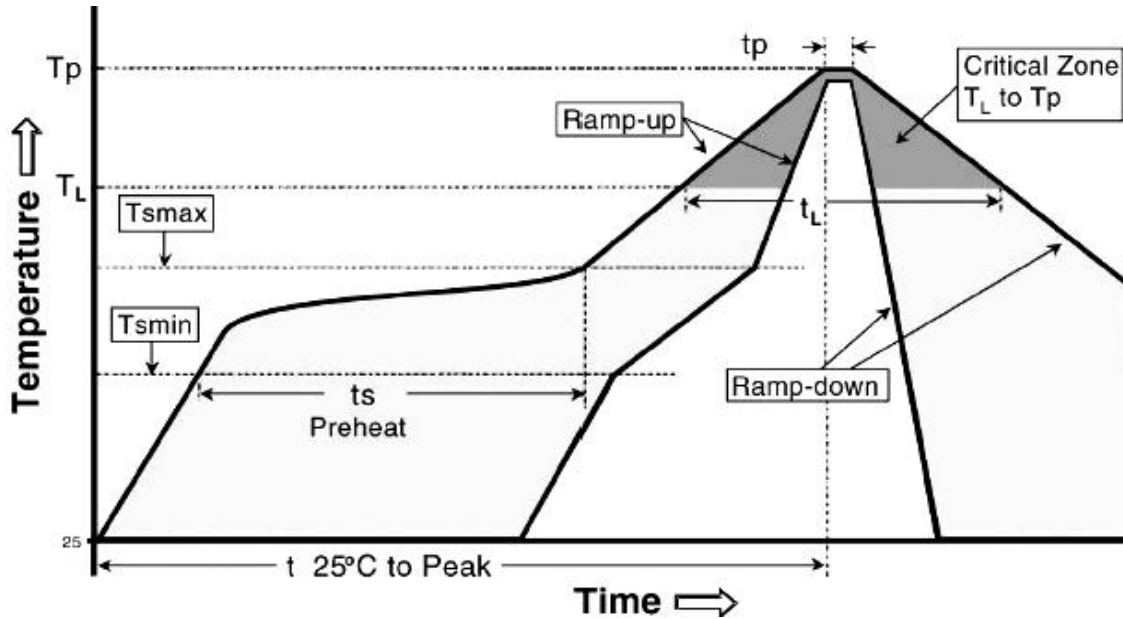

Profile Feature	Lead (Pb)-Free Assembly
Average ramp-up rate (T _{smax} to T _p)	3°C / second max.
Preheat - Temperature Min (T _{Amin}) - Temperature Max (T _{smax}) - Time (T _{Amin} to T _{smax}) (t _s)	150°C 200°C 60 -150 seconds
Time maintained above : - Temperature (T _l) - Time (T _l)	217°C 60-120 seconds
Peak Temperature (T _p)	MAX:260°C
Time within $\begin{matrix} +0 \\ -5 \end{matrix}$ °C of actual Peak Temperature (t _p) ²	10 seconds
Ramp-down Rate	6°C/second max.
Time 25°C to Peak Temperature	8 minutes max.

Allowed Re-flow times : 3 times

Remark : To avoid discoloration phenomena of chip on terminal electrodes, please use N2 Re-flow furnace.



**Automotive Thin Film Chip Resistors
RBA series Standard
(Halogen -Free)
AEC-Q200 compliant**

Document No

TRBA-XX0S001B

Issued date

2020/11/11

page

13/13

15. Manufacturing Country & City :

TA-I TECHNOLOGY CO., LTD. (Taiwan– Tao Yuan)

Tel: (+886) 3-3246169 Fax : (+886) 3-3246167

Associated companies :

(1)TA-I TECHNOLOGY (SU ZHOU) CO., LTD. (China – Su Zhou)

Tel :(+86) 512-63457879 Fax : (+86) 512-63457869

(2) TA-I TECHNOLOGY ELECTRONIC (DONGGUAN) CO., LTD. (China –Dongguan)

Tel : (+86) 769-8339-4790~3 Fax : (+86) 769-8339-4794

(3) FORTUNE TASK RESISTOR FACTORY (China – Dongguan)

Tel : (+86) 769-8339-4790~3 Fax : (+86) 769-8339-4794

(4) TAI OHM ELECTRONICS (M) SDN. BHD. (Malaysia – Penang)

Tel :(+60) 4- 3900480 Fax : (+60) 4-3901481

(5) P.T.TAI ELECTRONIC Indonesia (Indonesia – Jakarta)

Tel :(+62) 21-89830123 Fax : (+62) 21-89830703

单击下面可查看定价，库存，交付和生命周期等信息

[>>TA-I\(大毅\)](#)