

1SC3528VGB01MH08

- ◆ Outline (L* W*H): 3.5*2.8*1.8mm
- ◆ Good thermal dissipation & optical uniformity



Table of Contents

Product Code Method-----	2
Maximum Rating-----	2
Typical Product Characteristics-----	3
Range of Bins-----	3
Directive Characteristics-----	5
Electronic-Optical Characteristics-----	6
Dimensions -----	7
Packing-----	8
Precautions -----	9
Test Items and Results of Reliability-----	12

Features

- Forward current: R ≤ 50mA ;G&B ≤ 30mA
- Typical viewing angle 50% Iv:120°
- Lens color: white diffused
- RoHS and REACH-compliant
- ESD level ≥ 1kV(HBM)

Applications

- Indoor decorating
- Outdoor lighting for amusement
- Consumer electronics
- Other applications

Product Code Method

1 - S - C - 3528 - VGB0 - 1 - M - H - 08

① ② ③ ④ ⑤ ⑥ ⑦ ⑧ ⑨

①	②	③	④	⑤
Process Type	Category	LED Type	Lead Frame Size	Dice wavelength & luminous rank
1: normal process	S: SMD LED	C: PLCC top view D: PLCC side view	3528: 3.5*2.8mm	V:red G:green B:blue

⑥	⑦	⑧	⑨
Lap Polarity	Cap Color	PCB Module Code	Flow Code
1: common anode	M: white diffused	H: article mode	08: no expression above meaning for company

Maximum Rating(Ta=25°C)

Characteristics	Symbol	Typical	Unit
DC Forward Current	I _F	G&B ≤ 30 / R ≤ 50	mA
Pulse Forward Current ^{*3}	I _{PF}	80	mA
Reverse Voltage	V _R	-5	V
Power Dissipation	P _D	G&B:80 / R:100	mW
Junction Temperature	T _J	110	°C
Operating Temperature Range	T _{OP}	-40~80	°C
Storage Temperature Range	T _{STG}	-40~100	°C
Soldering Temperature ^{*4}	T _{SD}	260	°C

Notes 1: There is no maximum or typical voltage parameter

2: For other ambient, limited setting of current will be depended on de-rating curves.

3: Duty 1/10, pulse width 0.1ms

4: The maximum of soldering time is 5 seconds in T_{SD}

Typical Product Characteristics(Ta=25°C)

Characteristics	Symbol	Min	Typical	Max	Unit	Test condition	
Forward Voltage	V _F	R	1.8	1.9	2.6	V	I _F =20mA
		G	2.8	3.2	3.8		
		B	2.8	3.2	3.8		
Leakage Current	I _R	-	-	10	μA	V _R = -5V	
Luminous Intensity	I _v	R	160	235	-	mcd	I _F =20mA
		G	648	1000	-		
		B	160	235	-		
Dominant Wavelength	λ _d	R	615	-	630	nm	I _F =20mA
		G	519	-	534		
		B	461	-	476		
Viewing Angle	2θ _{1/2}	-	120	-	deg	I _F =20mA	

Notes: 1. Measurement Errors:

Forward Voltage: ±0.1V, Luminous Intensity: ±10%I_v, Dominant Wavelength: ±1.0nm

2. Electrical-Optical Characteristics (Ta=25°C)

Range of Bins
1).Luminous Intensity Bins (I_F=20mA)

Bin code		Min. I _v (mcd)	Max. I _v (mcd)
R	7	160	200
	8	200	250
	9	250	310
G	9	640	800
	10	800	1000
	11	1000	1250
B	7	160	200
	8	200	250
	9	250	310



■ Range of Bins

2).Dominant Wavelength Bins ($I_F=20mA$)

Bin Code		Min. λ_d (nm)	Max. λ_d (nm)
R	2	615	620
	3	620	625
	4	625	630
G	2	519	524
	3	524	529
	4	529	534
B	2	461	466
	3	466	471
	4	471	476



Electronic-Optical Characteristics

1). Relative Spectral Distribution

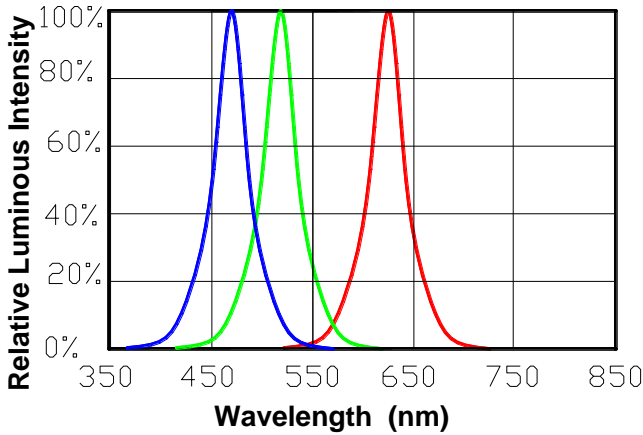

2). Typical Spatial Distribution

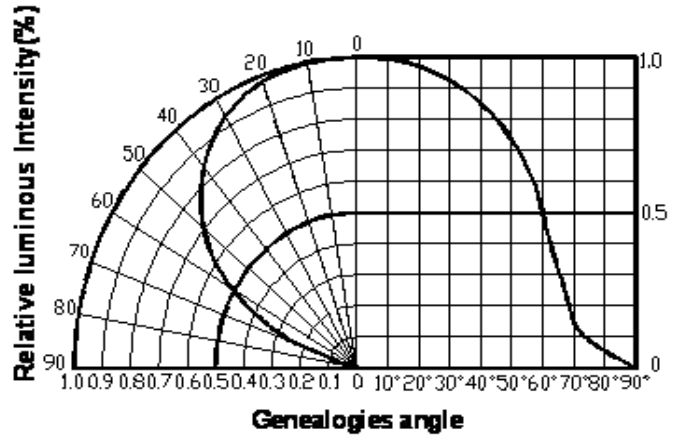

3). Relative Luminous Flux .Current

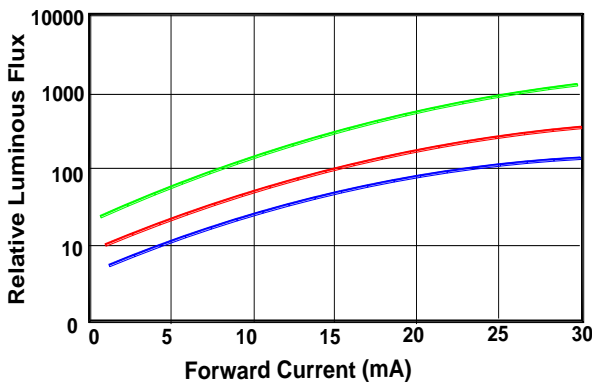

4). Relative Luminous Flux .Ambient Temperature

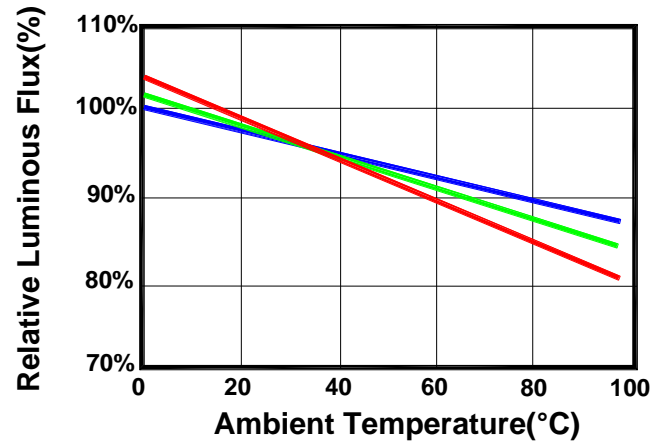

5). Electrical Characteristics

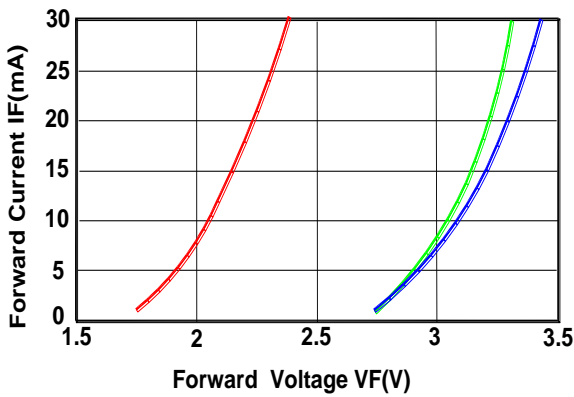

6). Forward Voltage Temperature

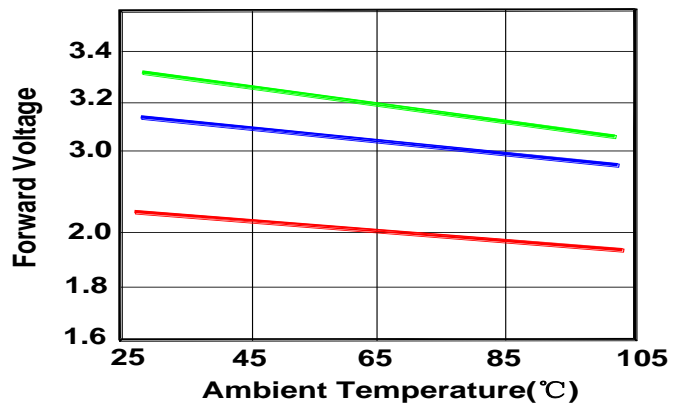

7). Wavelength and current

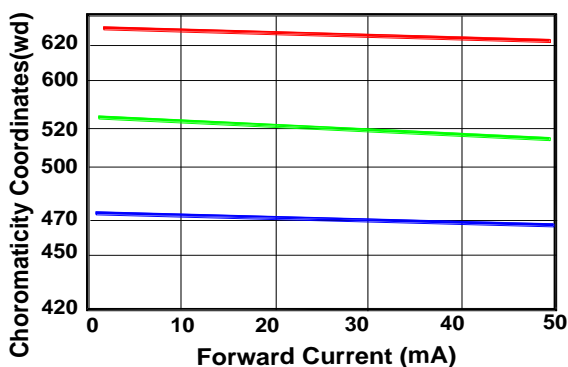

8). Thermal Design

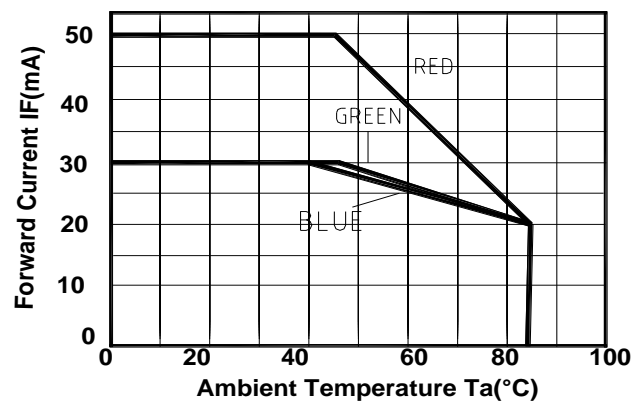

■ Dimensions

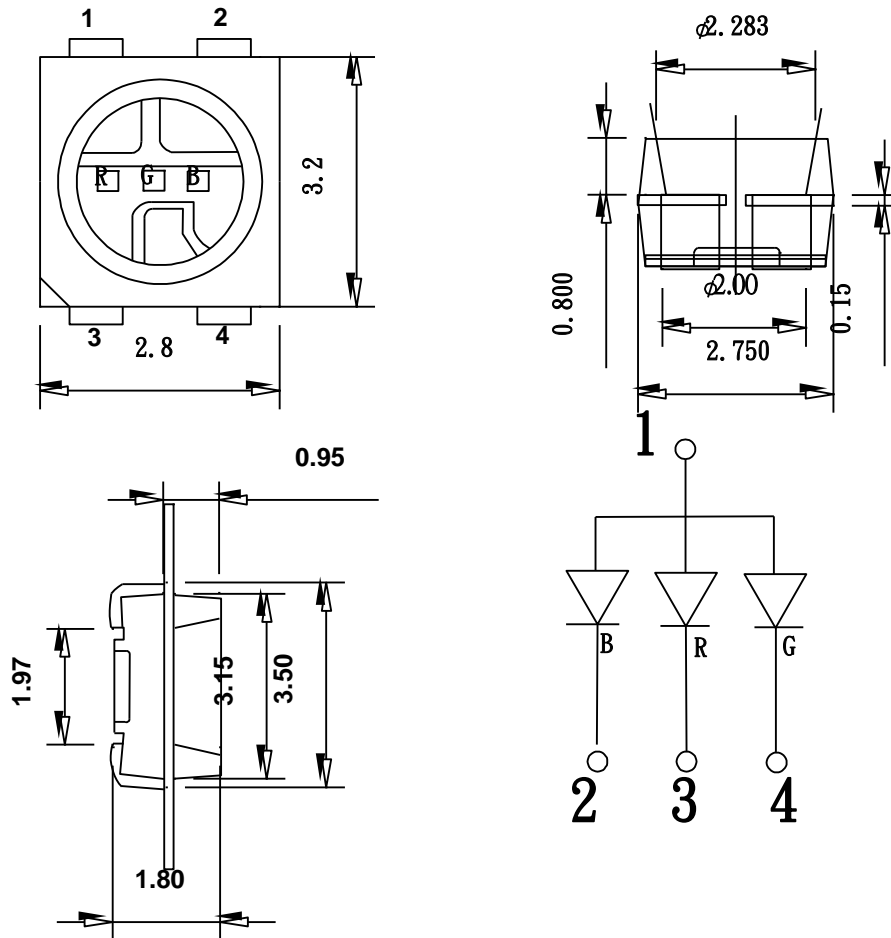

Recommend Padlayout

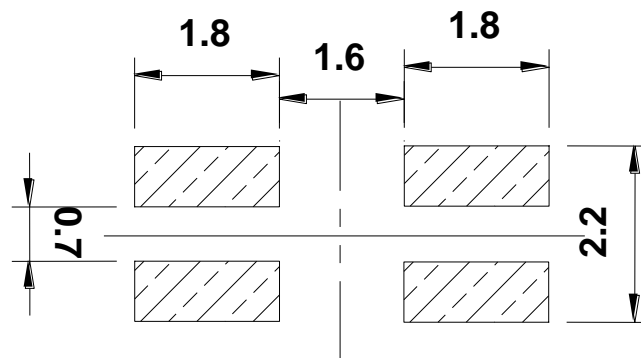

- § All dimensions are in millimeters.
- § Tolerance is ± 0.1 mm unless other specified
- § Specifications are subject to change without notice

■ Reflow Profile

1. I_R reflow soldering Profile for Lead Free solder

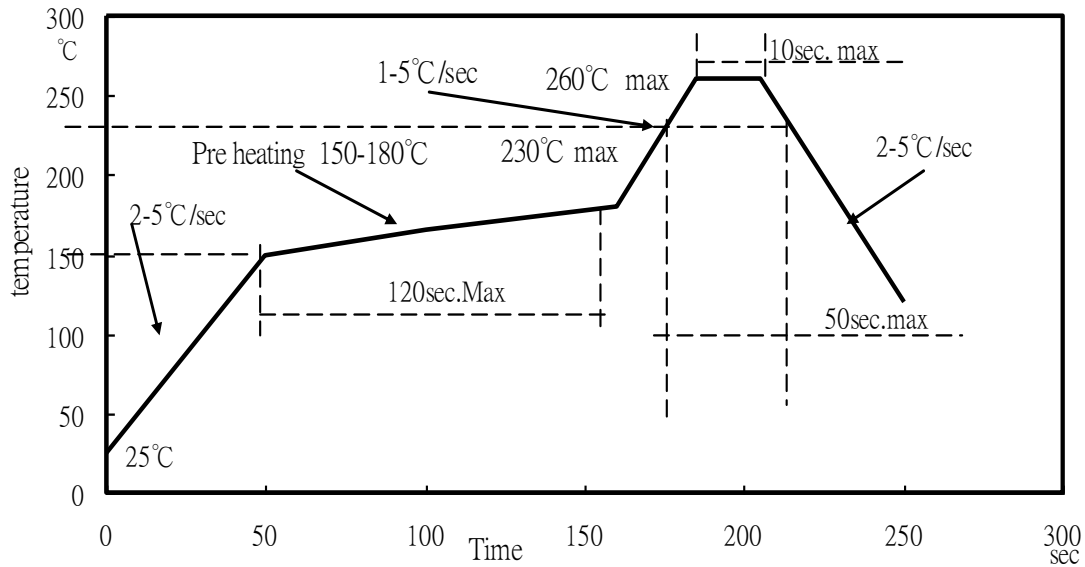

2. I_R reflow soldering Profile for Lead solder

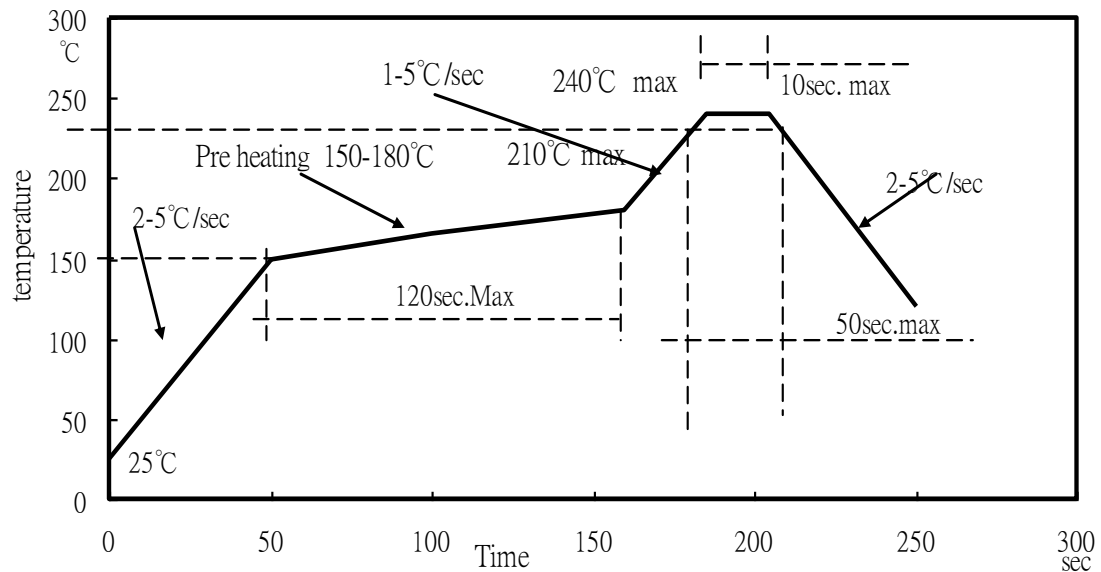

Notes:

1. We recommend the reflow temperature 240°C (±5°C).the maximum soldering temperature should be limited to 260°C.
2. Don't cause stress to the silicone resin while it is exposed to high temperature.
3. Number of reflow process shall be less than 3 times.

■ Test Circuit and Handling Precautions

1. Test circuit

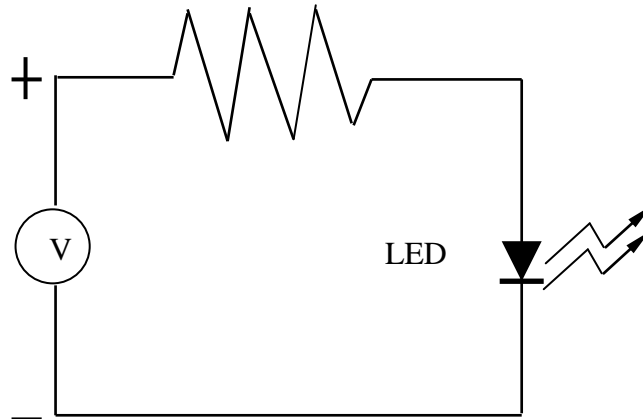

2. Handling precautions

2.1. Over-current-proof

Customer must apply resistors for protection; otherwise slight voltage shift will cause big current change (Burn out will happen).

2.2. Storage

1). It is recommended to store the products in the following conditions:

Humidity: 60% R.H. Max.

Temperature : 5°C~30°C (41°F~86°F)

2). Shelf life in sealed bag: 12 month at <5°C~30°C and <60% R.H. after the package is Opened, the products should be used within a week or they should be keeping to stored at $\leq 20\%$ R.H. with zip-lock sealed.

2.3. Baking

It is recommended to baking before soldering when the pack is unsealed after 24hrs.

The Conditions are as followings:

1). 70±3°C X 24hrs and <5%RH, for reel

2). 100±3°C X 2hrs, for single LED

3). 130±3°C X(15~30min), for single LED

It shall be normal to see slight color fading of carrier (light yellow) after baking in process

■ Packing

● Dimensions of Reel (Unit: mm)

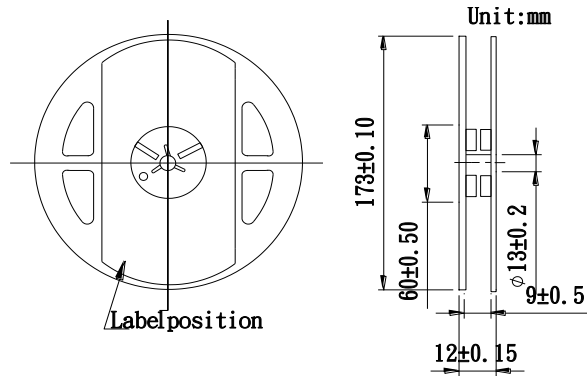

● Dimensions of Tape (Unit: mm)

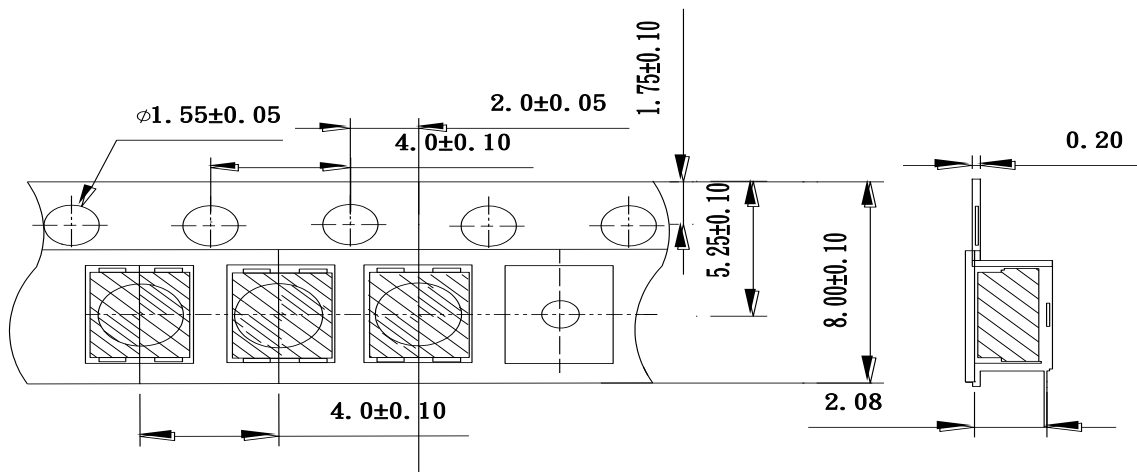

● Arrangement of Tape

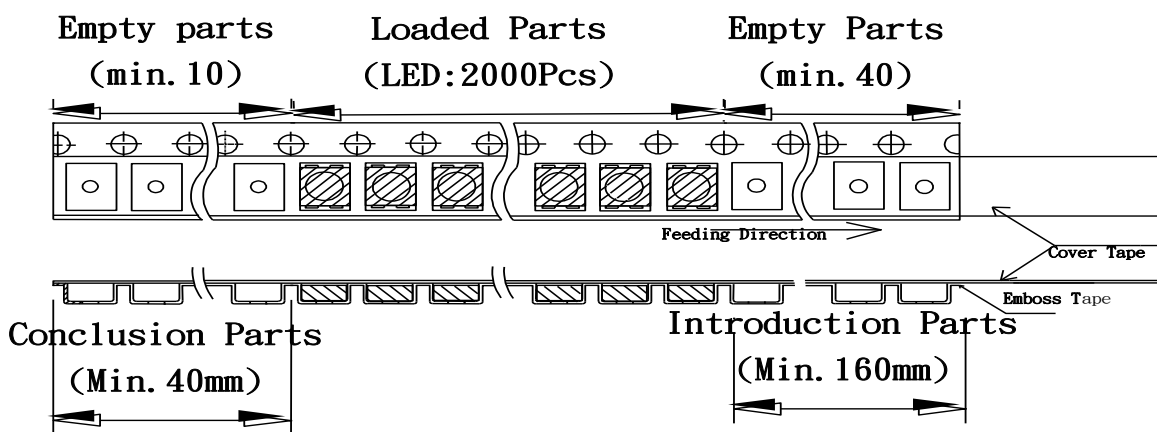

Notes:

1. Empty component pockets are sealed with top cover tape
2. The max loss number of SMD is 2pcs
3. The cathode is oriented towards the tape sprocket hole in accordance with ANSI/EIA RS-481 specifications
4. 2,000pcs per reel

■ Packing

● Packaging specifications

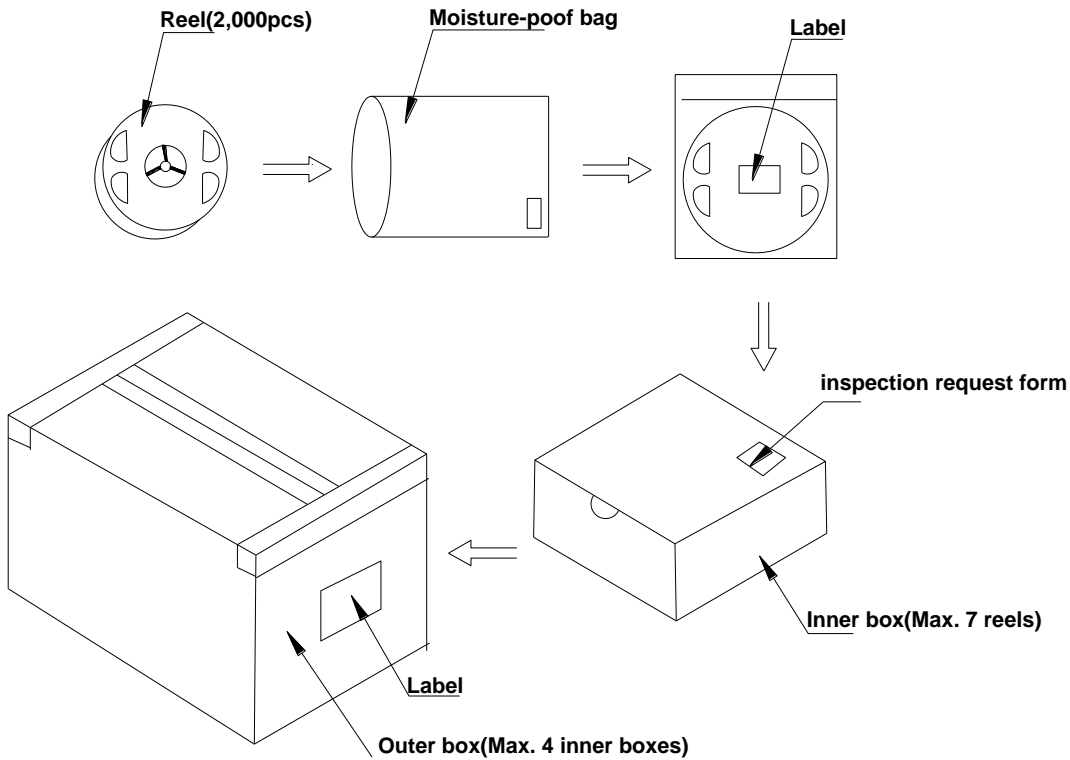

Notes:

Reeled product (max.2,000) is packed in a sealed moisture-proof bag. Seven bags are packed in an inner box (size: about 238 X 194 X 102 mm) and four inner boxes are in an outer box (size: about 410 X 254 X 229mm). On the label of moisture-proof bag, there should be the information of Part No., Lot No. and quantity number; also the total quantity number should be on inspection request form on outer box.

■ **Precautions**

1. Abnormal situation caused by improper setting of collet

To choose the right collet is the key issue in improving the product's quality. LED is different from other electronic components, which is not only about electrical output but also for optical output. This characteristic made LED more fragile in the process of SMT. If the collet's lowering down height is not well set, it will bring damage to the gold wire at the time of collet's picking up and loading which will cause the LED fail to light up, light up now and then or other quality problems

2. How to choose the collet

During SMT, please choose the collet that has larger outer diameter than the lighting area of lens, in case that improper position of collet will damage the gold wire inside the LED. Different collets fit for different products, please refer to the following pictures cross out

Outer diameter of collet should be larger than the lighting area

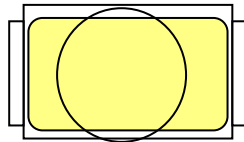

Picture 1(√)

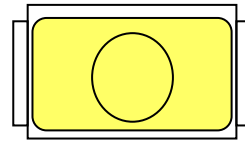

Picture 2(X)

3. Other points for attention

- A. No pressure should be exerted to the epoxy shell of the SMD under high temperature.
- B. Do not scratch or wipe the lens since the lens and gold wire inside are rather fragile and cross out easy to break.
- C. LED should be used as soon as possible when being taken out of the original package, and should be stored in anti-moisture and anti-ESD package.

4. This usage and handling instruction is only for your reference.



■ Test Items and Results of Reliability

Test Item	Test Conditions	Duration/ Cycle	Number of Damage	Reference
Temperature Cycle	-40°C 30min ↑↓1min 100°C 30min	100 cycles	0/22	JEITA ED-4701 300 303
High Temperature Storage	T _a =100°C±5°C	1000 hrs	0/22	EIAJED-4701 200 201
High Humidity Heat Life Test	T _a =85°C RH=85% I _F =20mA	500 hrs	0/22	Tested with Brightek standard
Humidity Heat Storage	T _a =85°C RH=85%	1000 hrs	0/22	EIAJED-4701 100 103
Life Test	T _a =25°C I _F =20mA	1000 hrs	0/22	Tested with Brightek standard
Low Temperature Life Test	T _a =-40°C I _F =20mA	1000 hrs	0/22	Tested with Brightek standard
High Temperature Life Test	T _a =85°C I _F =20mA	1000 hrs	0/22	Tested with Brightek standard

*Criteria for Judging				
Item	Symbol	Condition	Criteria for Judgment of Pass	
			Min	Max
Forward Voltage	V _F	I _F =20mA	-	USL* ¹ ×1.1
Reverse Current	I _R	V _R = -5V	-	10μA
Luminous Intensity	I _v	I _F =20mA	LSL* ² ×0.7	-

[Note] USL*¹: Upper Specification Level

LSL*²: Lower Specification Level

单击下面可查看定价，库存，交付和生命周期等信息

[>>弘硕](#)