



芯基科技

MPVA7N65

Power MOSFET

SWITCHING REGULATOR APPLICATIONS

Features

- High Voltage: $BV_{DSS}=650V(\text{Min.})$
- Low C_{RSS} : $C_{RSS}=8pF(\text{Typ.})$
- Low gate charge : $Q_g=20nC(\text{Typ.})$
- Low $R_{DS(on)}$: $R_{DS(on)}=1.35\Omega(\text{Max.})$

Ordering Information

Type No.	Marking	Package Code
MPVA7N65	MPVA7N65	TO-220F-3L

PIN Connection

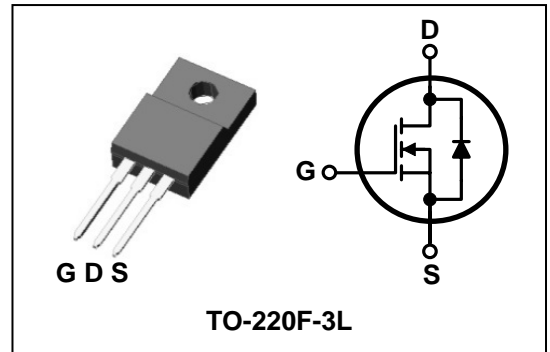

Outline Dimensions

unit : mm

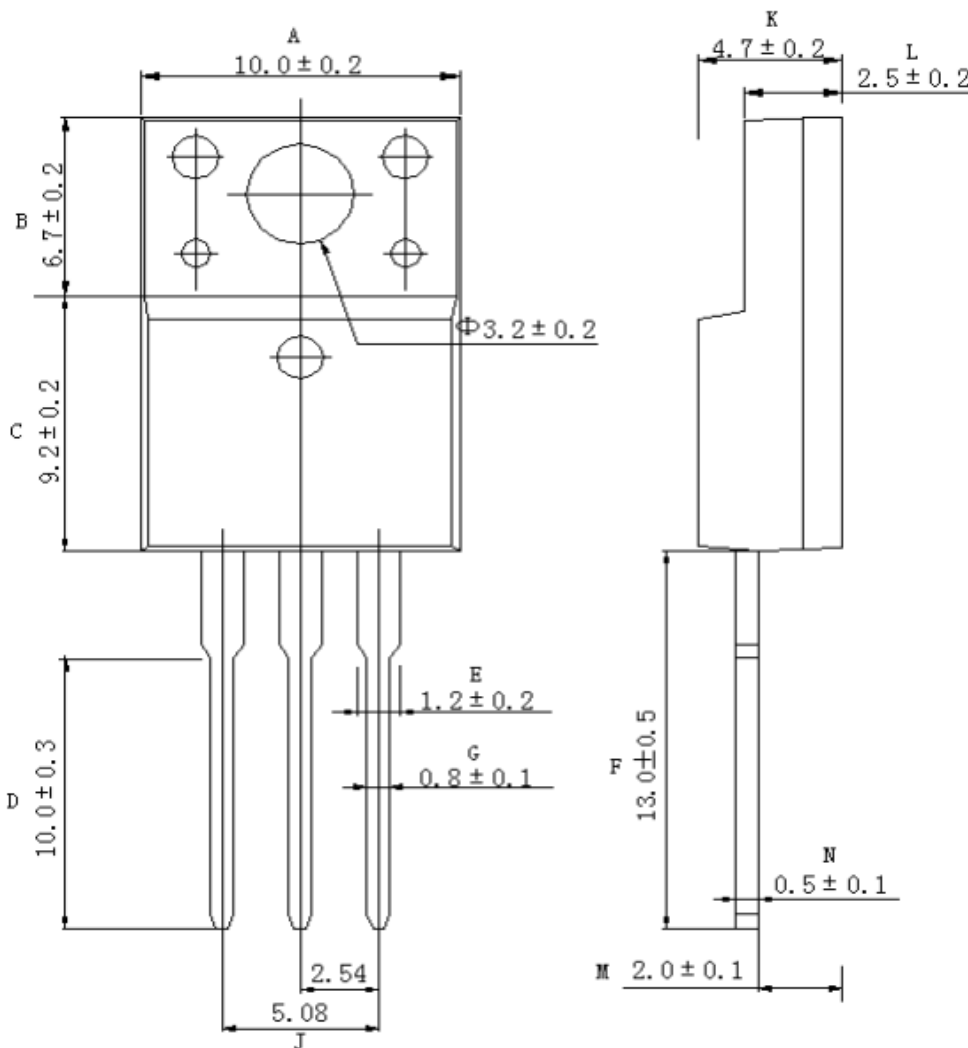

PIN Connections

1. Gate
2. Drain
3. Source



芯基科技

MPVA7N65

Power MOSFET

Absolute maximum ratings

(Tc=25°C)

Characteristic	Symbol	Rating	Unit	
Drain-source voltage	V_{DSS}	650	V	
Gate-source voltage	V_{GSS}	±30	V	
Drain current (DC) *	I_D	(Tc=25°C)	7	A
		(Tc=100°C)	4.0	A
Drain current (Pulsed) *	I_{DM}	28	A	
Drain power dissipation	P_D	46	W	
Avalanche current (Single) ②	I_{AS}	7	A	
Single pulsed avalanche energy ②	E_{AS}	230	mJ	
Avalanche current (Repetitive) ①	I_{AR}	7	A	
Repetitive avalanche energy ①	E_{AR}	21.7	mJ	
Junction temperature	T_J	150	°C	
Storage temperature range	T_{stg}	-55~150		

* Limited by maximum junction temperature

Characteristic		Symbol	Typ.	Max	Unit
Thermal resistance	Junction-case	$R_{th(J-C)}$	-	4.16	°C/W
	Junction-ambient	$R_{th(J-a)}$	-	62.5	



芯基科技

MPVA7N65

Power MOSFET

Electrical Characteristics

(Tc=25°C)

Characteristic	Symbol	Test Condition	Min.	Typ.	Max.	Unit	
Drain-source breakdown voltage	BV_{DSS}	$I_D=250\mu A, V_{GS}=0$	650	-	-	V	
Gate threshold voltage	$V_{GS(th)}$	$I_D=250\mu A, V_{DS}=V_{GS}$	2.0	-	4.0	V	
Drain-source cut-off current	I_{DSS}	$V_{DS}=650V, V_{GS}=0V$	-	-	1	μA	
Gate leakage current	I_{GSS}	$V_{DS}=0V, V_{GS}=\pm 30V$	-	-	± 100	nA	
Drain-source on-resistance ④	$R_{DS(on)}$	$V_{GS}=10V, I_D=3.5A$			1.35	Ω	
Forward transfer conductance ④	g_{fs}	$V_{DS}=10V, I_D=3.5A$	-	7.3	-	S	
Input capacitance	C_{iss}	$V_{GS}=0V, V_{DS}=25V$ $f=1MHz$		1100	1550	pF	
Output capacitance	C_{oss}			100	140		
Reverse transfer capacitance	C_{rss}			8	13		
Turn-on delay time	$t_{d(on)}$	$V_{DD}=325V, I_D=7A$ $R_G=25\Omega$	-	29	-	ns	
Rise time	t_r		-	48	-		
Turn-off delay time	$t_{d(off)}$		③④	-	39		-
Fall time	t_f		-	33	-		
Total gate charge	Q_g	$V_{DS}=400V, V_{GS}=10V$ $I_D=7A$	-	20		nC	
Gate-source charge	Q_{gs}		③④	-	4.0		
Gate-drain charge	Q_{gd}		-	-	7.0		

Source-Drain Diode Ratings and Characteristics

(Tc=25°C)

Characteristic	Symbol	Test Condition	Min	Typ	Max	Unit
Source current (DC)	I_S	Integral reverse diode in the MOSFET	-	-	7	A
Source current (Pulsed) ①	I_{SM}		-	-	28	
Forward voltage ④	V_{SD}	$V_{GS}=0V, I_S=7A$	-	-	1.4	V
Reverse recovery time	t_{rr}	$I_S=7A, V_{GS}=0,$ $di_S/dt=100A/\mu s$	-	365	-	ns
Reverse recovery charge	Q_{rr}		-	3.4	-	μC

Note ;

- ① Repetitive Rating : Pulse Width Limited by Maximum Junction Temperature
- ② $L=10.0mH, I_{AS}=7A, V_{DD}=50V, R_G=25\Omega$
- ③ Pulse Test : Pulse Width < 300us, Duty cycle $\leq 2\%$
- ④ Essentially independent of operating temperature



芯基科技

MPVA7N65

Power MOSFET

Electrical Characteristic Curves

Fig. 1 $I_D - V_{DS}$

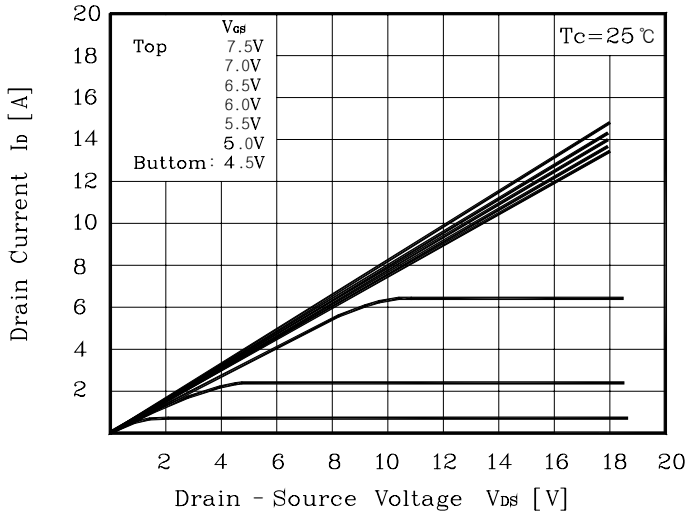

Fig. 2 $I_D - V_{GS}$

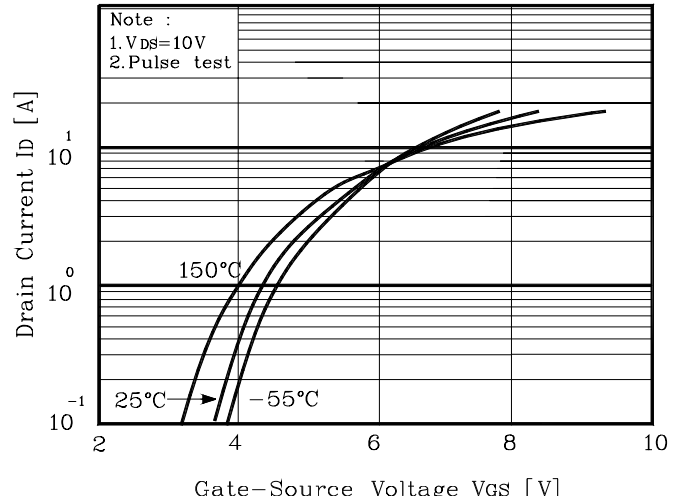

Fig. 3 $R_{DS(on)} - I_D$

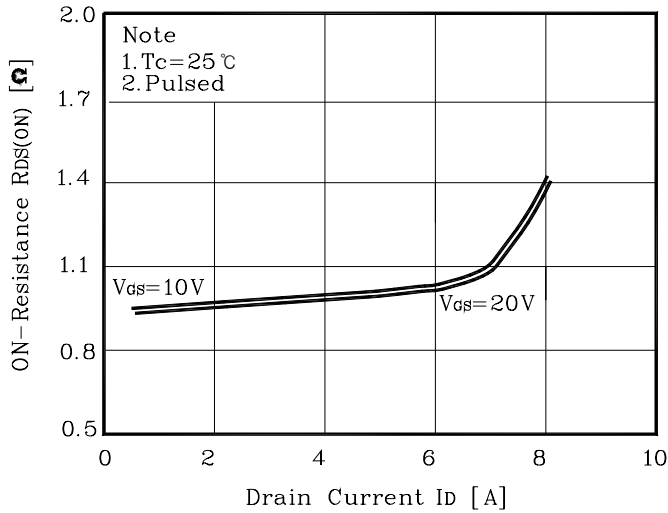

Fig. 4 $I_S - V_{SD}$

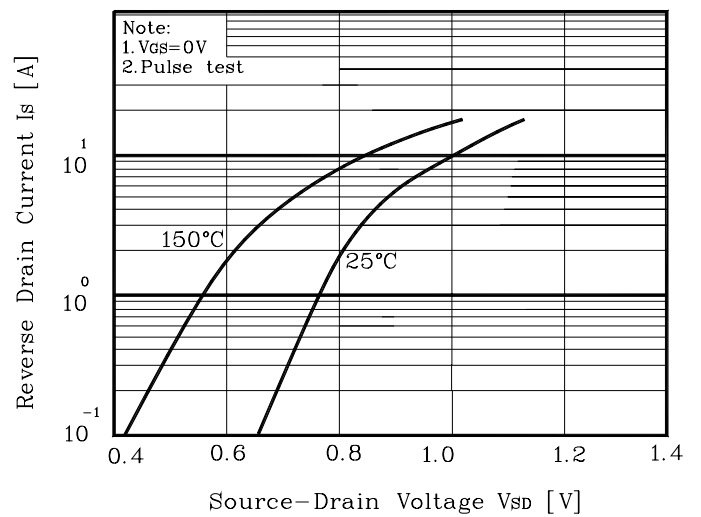

Fig. 5 Capacitance - V_{DS}

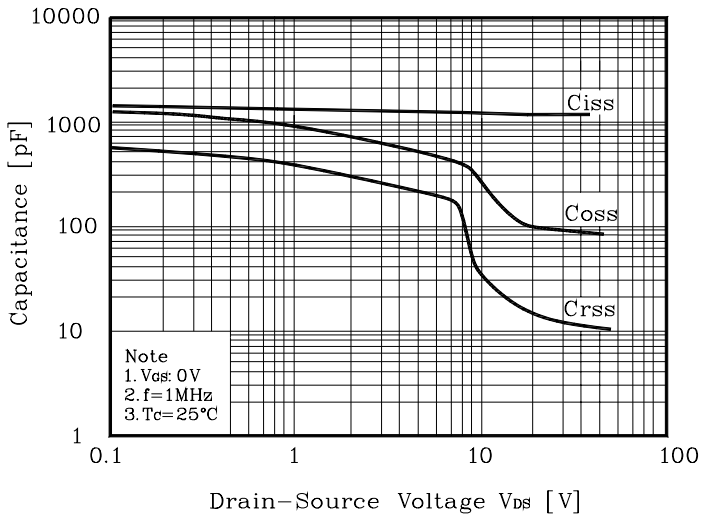
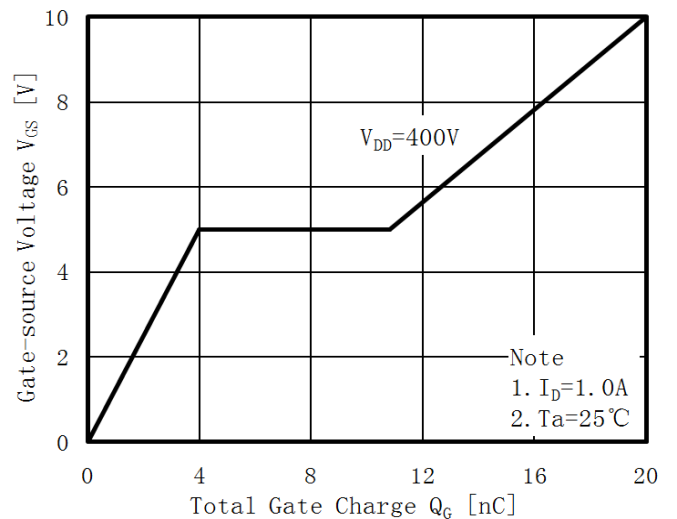

Fig. 6 $V_{GS} - Q_G$





芯普微科技

MPVA7N65

Power MOSFET

Electrical Characteristic Curves

Fig. 7 $V_{DSS} - T_J$

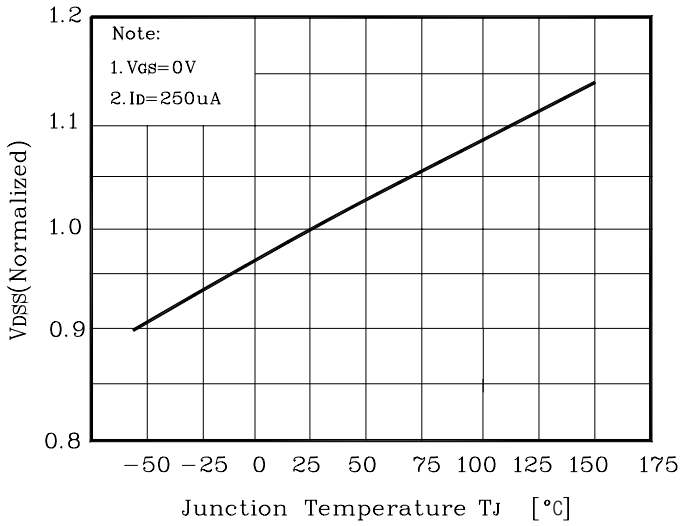

Fig.8 $R_{DS(on)} - T_J$

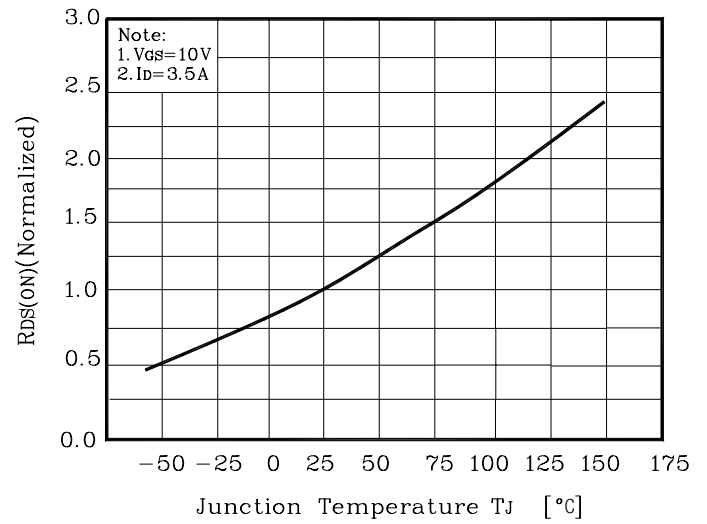

Fig. 9 $I_D - T_C$

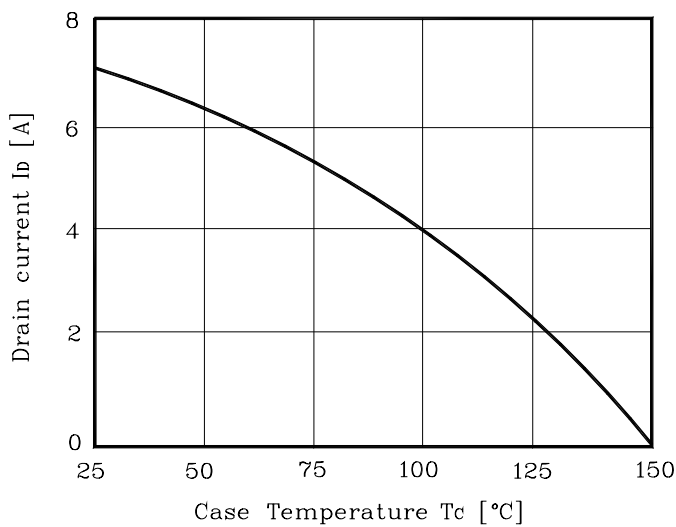

Fig. 10 Safe Operating Area

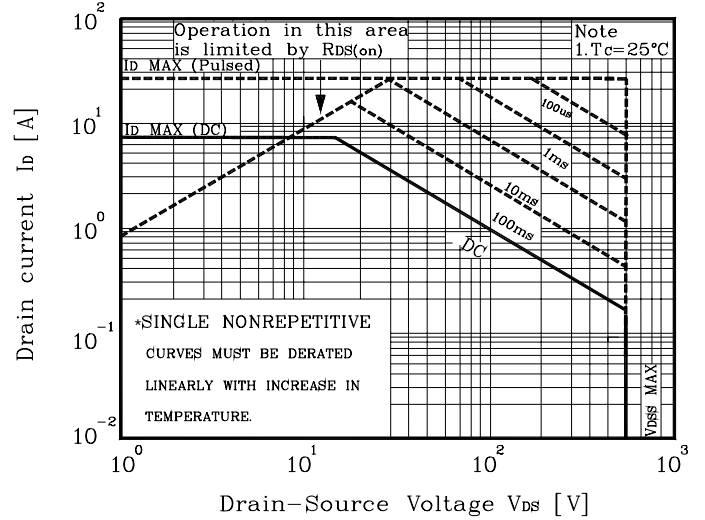

Fig. 10 Gate Charge Test Circuit & Waveform

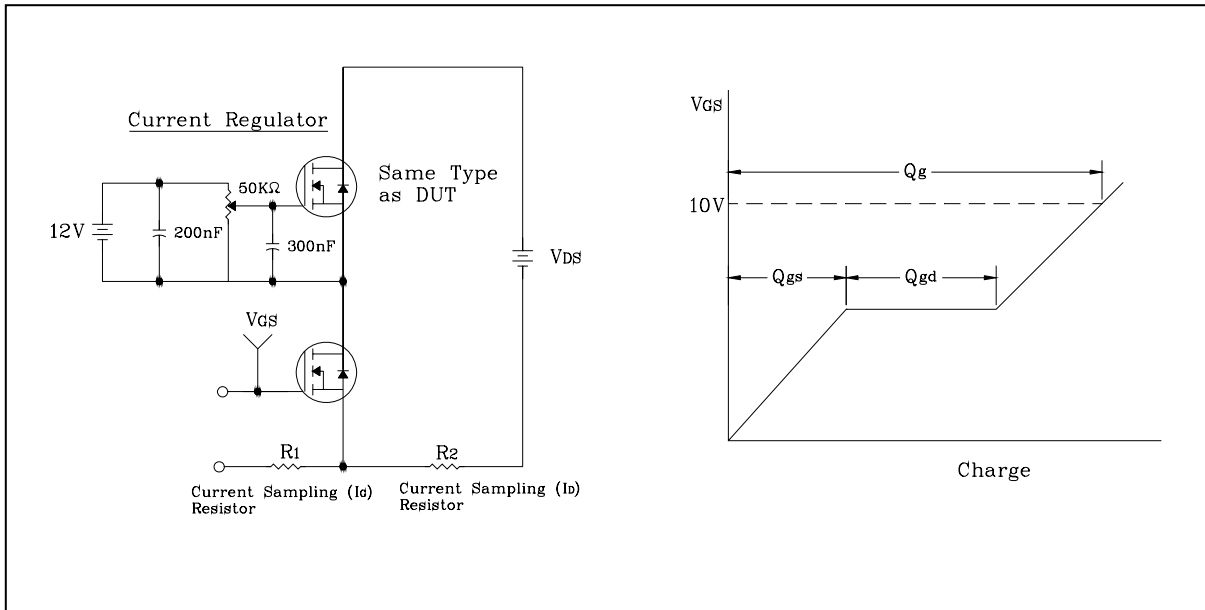

Fig. 11 Resistive Switching Test Circuit & Waveform

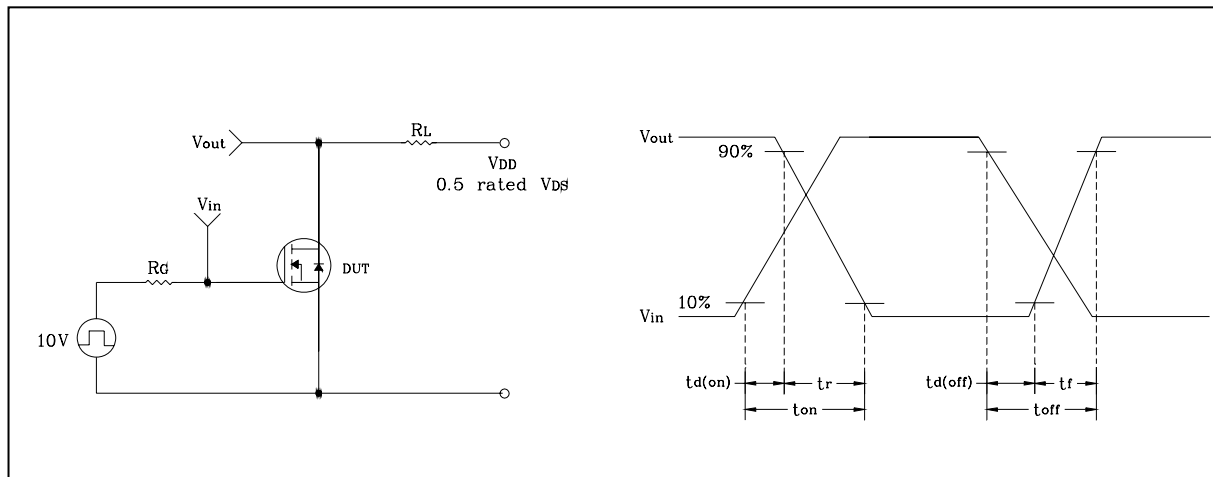

Fig. 12 E_{AS} Test Circuit & Waveform

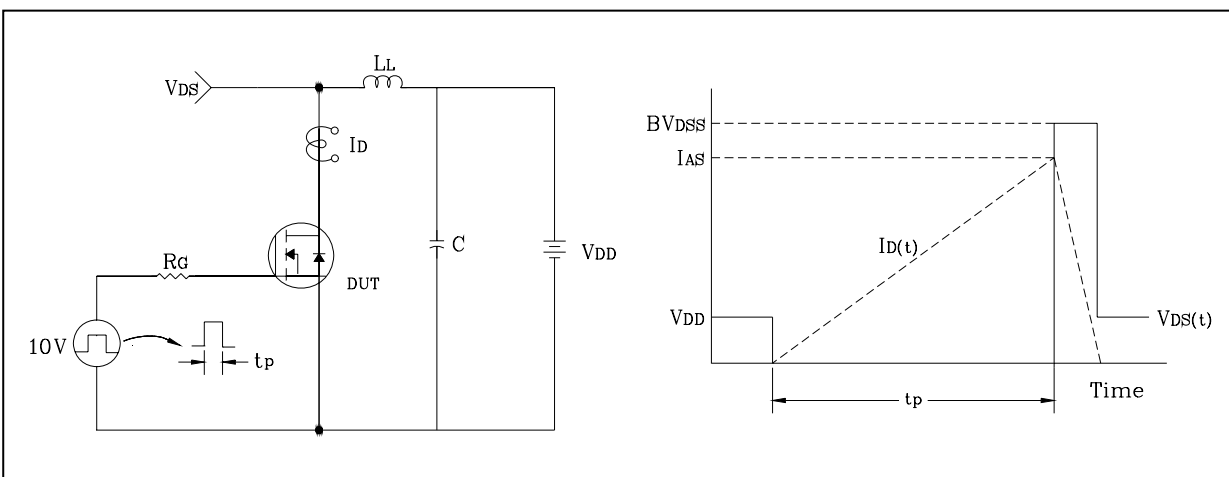
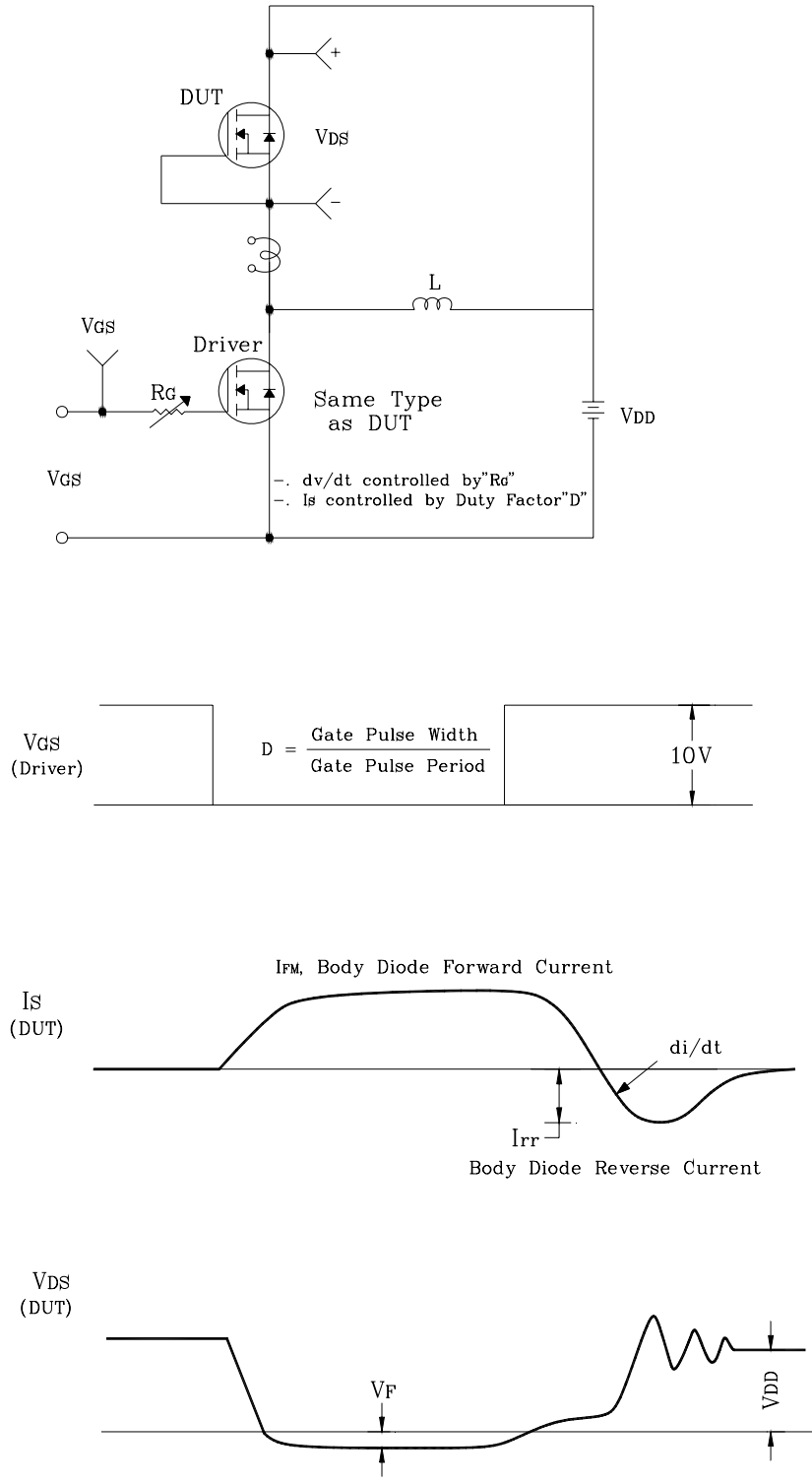

Fig. 13 Diode Reverse Recovery Time Test Circuit & Waveform



单击下面可查看定价，库存，交付和生命周期等信息

[>>芯长征](#)