

LMBT5401LT1G

S-LMBT5401LT1G

High Voltage Transistor

1. FEATURES

- We declare that the material of product compliance with RoHS requirements and Halogen Free.
- S- prefix for automotive and other applications requiring unique site and control change requirements; AEC-Q101 qualified and PPAP capable.

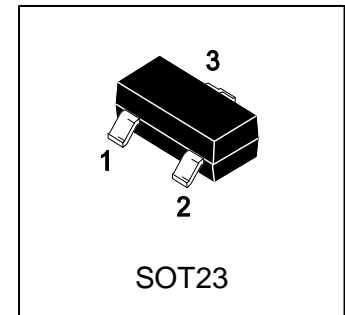

2. DEVICE MARKING AND ORDERING INFORMATION

Device	Marking	Shipping
LMBT5401LT1G	2L	3000/Tape&Reel
LMBT5401LT3G	2L	10000/Tape&Reel

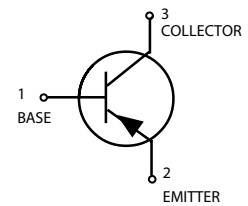

3. MAXIMUM RATINGS(Ta = 25°C)

Parameter	Symbol	Limits	Unit
Collector-Emitter Voltage	V _{CEO}	-150	V
Collector-Base voltage	V _{CBO}	-160	V
Emitter-Base Voltage	V _{EBO}	-5	V
Collector current — Continuous	I _C	-500	mA

4. THERMAL CHARACTERISTICS

Parameter	Symbol	Limits	Unit
Total Device Dissipation, FR-5 Board (Note 1) @ TA = 25°C Derate above 25°C	PD	225 1.8	mW mW/°C
Thermal Resistance, Junction-to-Ambient	R _{θJA}	556	°C/W
Total Device Dissipation, Alumina Substrate, (Note 2) @ TA = 25°C Derate above 25°C	PD	300 2.4	mW mW/°C
Thermal Resistance, Junction-to-Ambient	R _{θJA}	417	°C/W
Junction and Storage temperature	T _J , T _{stg}	-55~+150	°C

1. FR-5 = 1.0×0.75×0.062 in.

2. Alumina = 0.4 x 0.3 x 0.024 in. 99.5% alumina.

5. ELECTRICAL CHARACTERISTICS (Ta= 25°C)
OFF CHARACTERISTICS

Characteristic	Symbol	Min.	Typ.	Max.	Unit
Collector-Emitter Breakdown Voltage (IC = -1.0mA, IB=0)	V(BR)CEO	-150	-	-	V
Collector-Base Breakdown voltage (IC = -100μA, IE=0)	V(BR)CBO	-160	-	-	V
Emitter-Base Breakdown Voltage (IE = -10μA, IC=0)	V(BR)EBO	-5	-	-	V
Collector Cutoff Current (VCB = -120 V, IE=0) (VCB = -120 V, IE=0, TA=100°C)	ICBO	-	-	-50	nA μA
Emitter-Base cut-off current (IC = 0, VEB=-5.0V)	IEBO	-	-	-50	nA
Collector-Emitter cutoff Current (VCE = -150V, IB=0)	ICEO	-	-	-10	μA

ON CHARACTERISTICS

DC Current Gain (IC = -1.0mA, VCE = -5.0 V) (IC = -10 mA, VCE = -5.0 V) (IC = -50 mA, VCE = -5.0 V)	HFE	50 60 50	- - -	- 240 -	
Collector-Emitter Saturation Voltage (IC = -10 mA, IB = -1.0 mA) (IC = -50 mA, IB = -5.0 mA)	VCE(S)	- -	- -	-0.2 -0.5	V
Base-Emitter Saturation Voltage (IC = -10 mA, IB = -1.0 mA) (IC = -50 mA, IB = -5.0 mA)	VBE(S)	- -	- -	-1 -1	V

SMALL-SIGNAL CHARACTERISTICS

Current-Gain — Bandwidth Product (IC = -10 mA, VCE = -10 V, f = 100 MHz)	fT	100	-	300	MHz
Output Capacitance (VCB = -10 V, IE = 0, f = 1.0 MHz)	Cobo	-	-	6	PF
Small-Signal Current Gain (IC = -1.0mA, VCE = -10V, f = 1.0 kHz)	hfe	40	-	200	
Noise Figure (IC = -200 μA, VCE = -5.0 V, Rs=10Ω, f=1.0 kHz)	NF	-	-	8	dB

6.ELECTRICAL CHARACTERISTICS CURVES

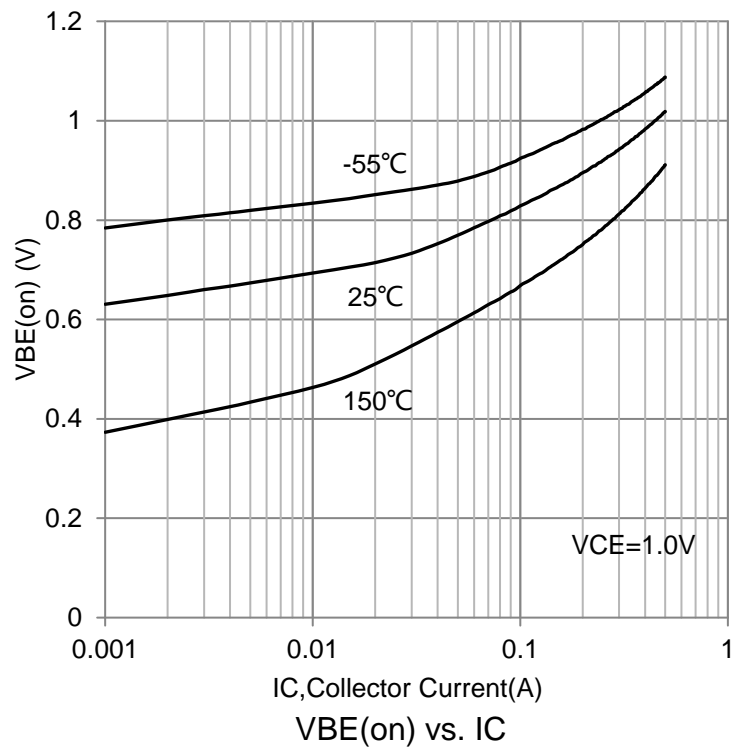
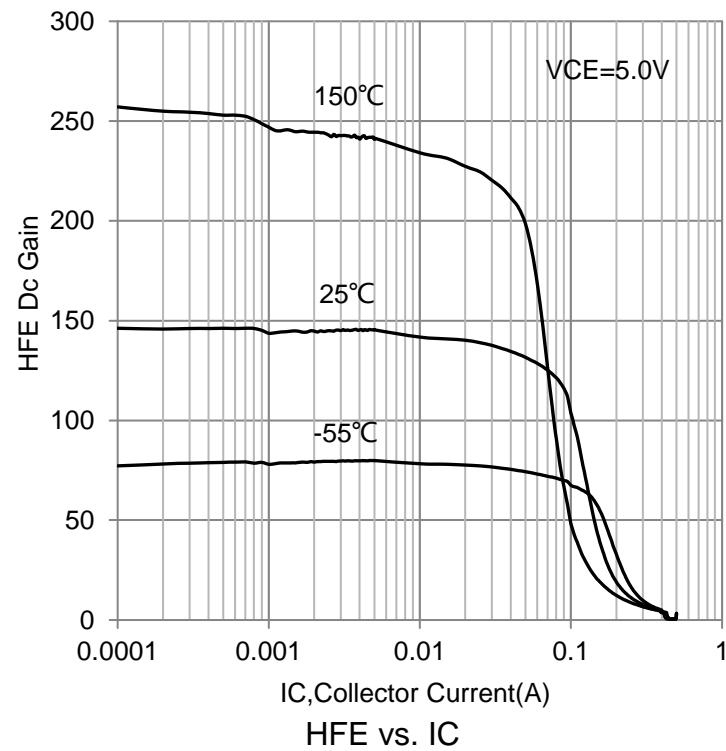
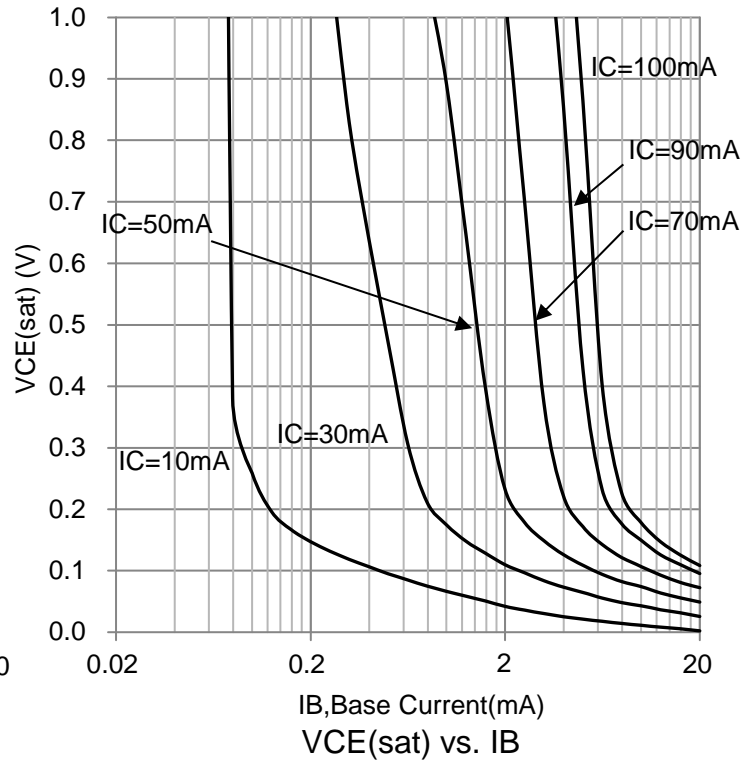
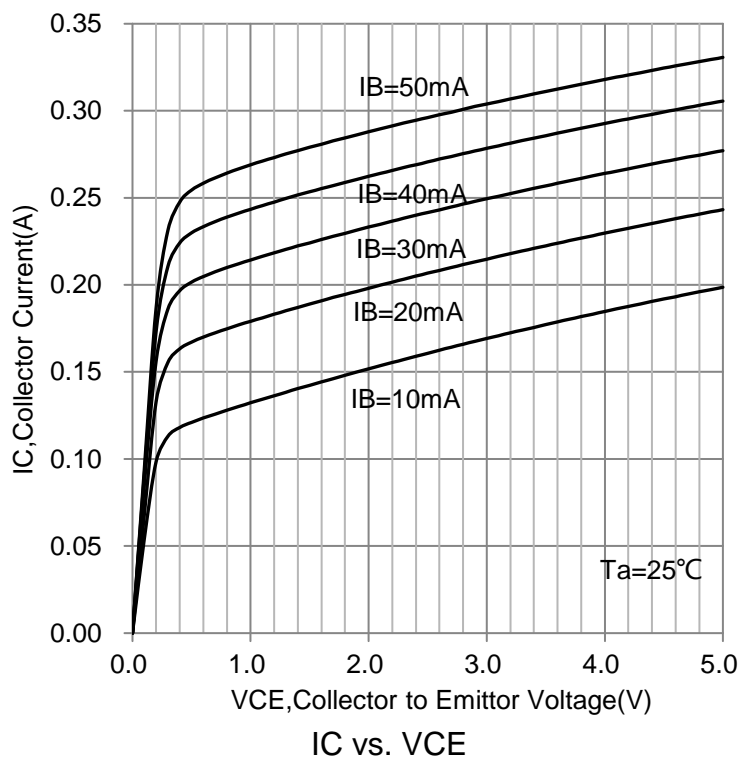

6.ELECTRICAL CHARACTERISTICS CURVES(Con.)

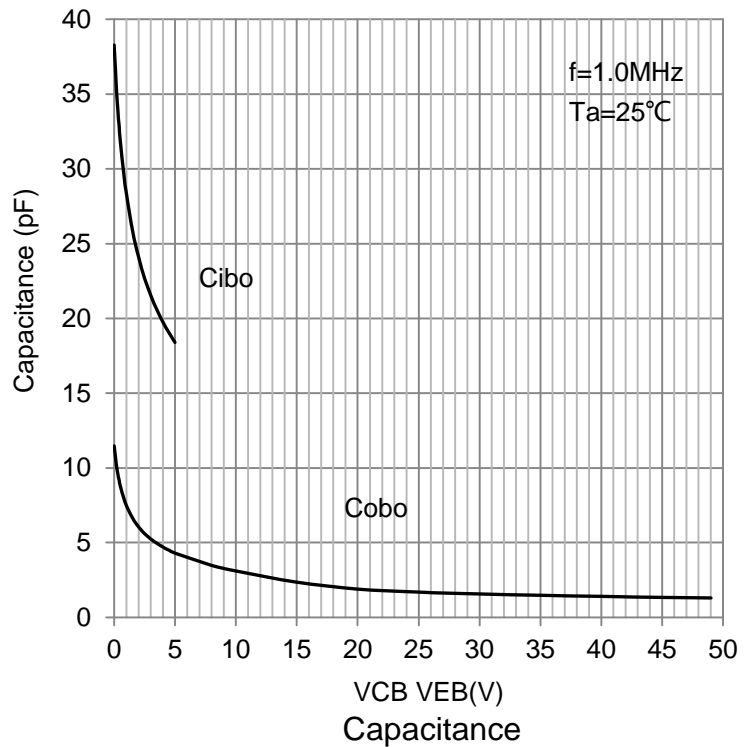
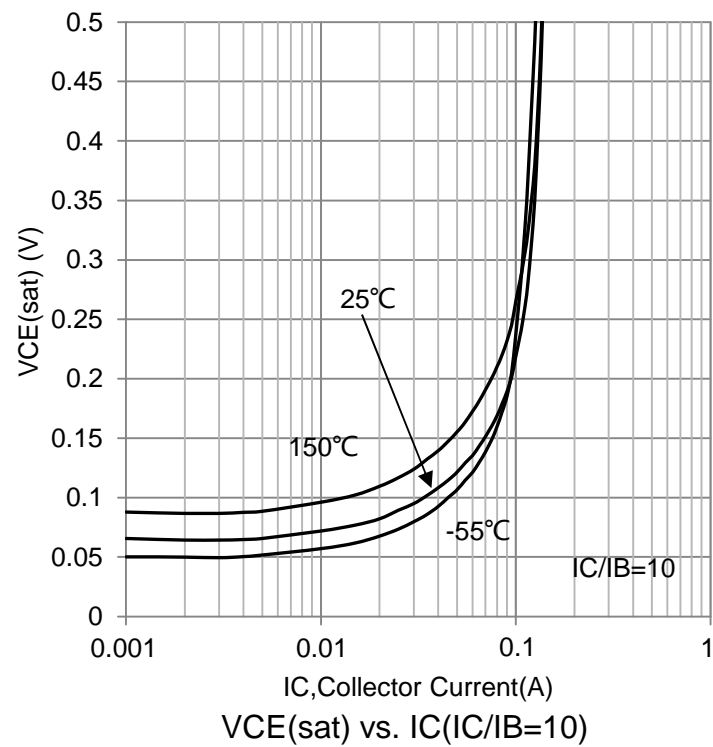
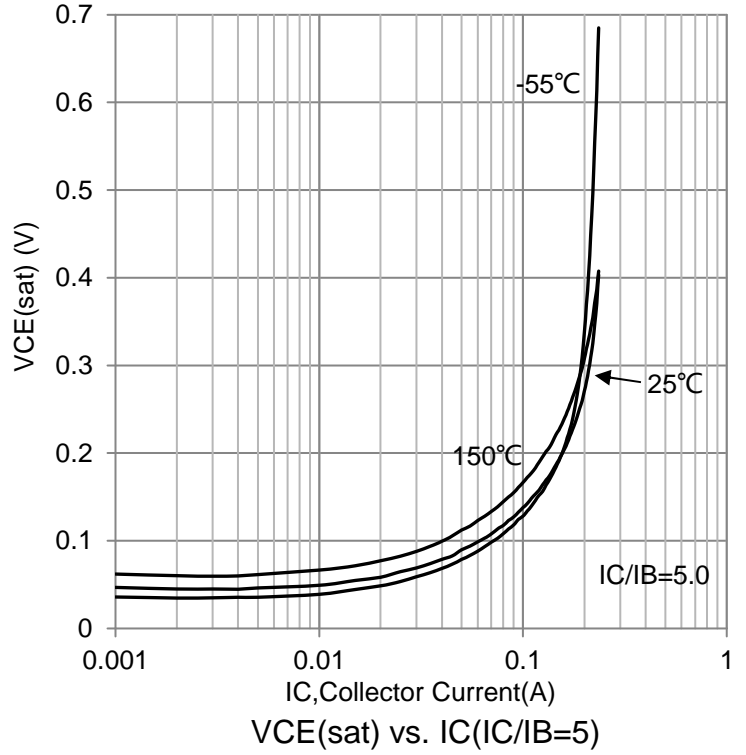
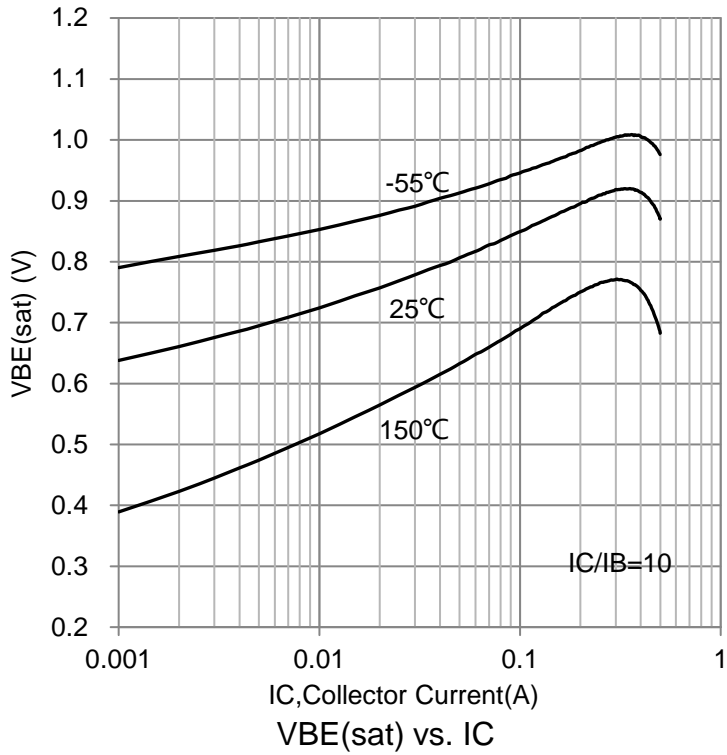

7. OUTLINE AND DIMENSIONS

Notes:

1. DIMENSIONING AND TOLERANCING PER ANSI Y14.5M, 1982.
2. CONTROLLING DIMENSION: MILLIMETERS.
3. MAXIMUM LEAD THICKNESS INCLUDES LEAD FINISH. MINIMUM LEAD THICKNESS IS THE MINIMUM THICKNESS OF BASE MATERIAL.
4. DIMENSIONS D AND E DO NOT INCLUDE MOLD FLASH, PROTRUSIONS OR GATE BURRS.

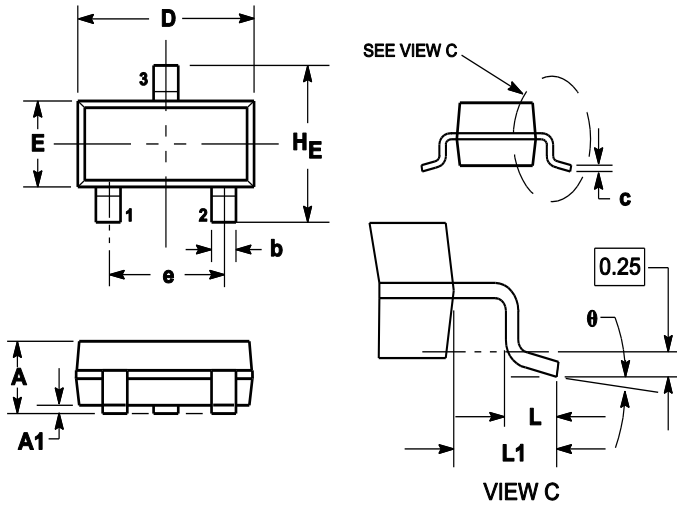

DIM	MILLIMETERS			INCHES		
	MIN	NOM	MAX	MIN	NOM	MAX
A	0.89	1	1.11	0.035	0.04	0.044
A1	0.01	0.06	0.1	0.001	0.002	0.004
b	0.37	0.44	0.5	0.015	0.018	0.02
c	0.09	0.13	0.18	0.003	0.005	0.007
D	2.80	2.9	3.04	0.11	0.114	0.12
E	1.20	1.3	1.4	0.047	0.051	0.055
e	1.78	1.9	2.04	0.07	0.075	0.081
L	0.10	0.2	0.3	0.004	0.008	0.012
L1	0.35	0.54	0.69	0.014	0.021	0.029
HE	2.10	2.4	2.64	0.083	0.094	0.104
θ	0°	---	10°	0°	---	10°

8. SOLDERING FOOTPRINT

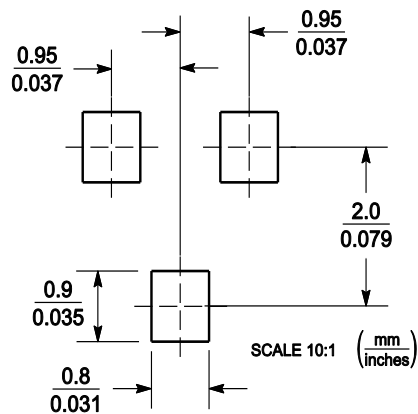

单击下面可查看定价，库存，交付和生命周期等信息

[>>LRC\(乐山无线电\)](#)