

TLE4955C

Differential Hall Effect Transmission Speed Sensors



Features

- High magnetic sensitivity
- Large operating airgap
- Two wire PWM current interface
- Fast start-up
- Dynamic self calibration principle
- Adaptive hysteresis
- Detection of rotation direction
- High vibration suppression capability
- From zero speed up to 12 kHz¹⁾
- Wide operating temperature ranges
- High resistance to piezo effects
- Single chip solution
- Magnetic encoder and ferromagnetic wheel application
- South and north pole pre-induction possible
- Green package with lead-free plating
- Module style package with integrated overmolded capacitor²⁾
 - 1.8 nF between V_{DD} and GND
- AEC-Q100 qualified
- Green Product (RoHS compliant)

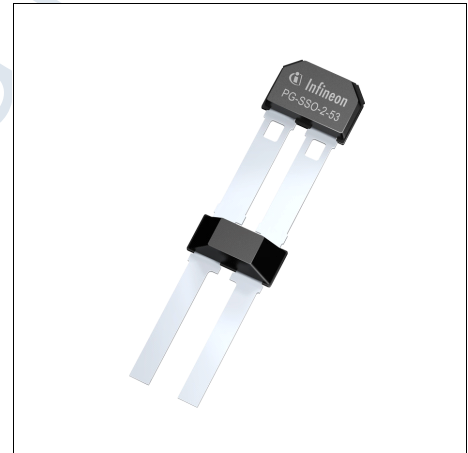

Applications

The TLE4955C is an integrated differential Hall effect sensor for transmission applications with two wire PWM output current interface. Its basic function is to provide information about rotational speed and direction of rotation to the transmission control unit. TLE4955C includes a sophisticated algorithm which actively suppresses vibration while keeping excellent air gap performance.

Description

Product Name	Ordering Code	Marking	Package
TLE4955C	SP001368954	55BIC0	PG-SSO-2-53

1) Magnetic parameters are valid and characterized for $f > 1$ Hz

2) Value of capacitor: 1.8 nF +/-10% (excluded drift because of temperature and over lifetime); ceramic: X8R; maximum voltage: 50 V.

Table of Contents

	Features	1
	Applications	1
	Description	1
	Table of Contents	2
1	Functional Description	3
1.1	Sensor Assembly	3
1.2	Block Diagram	5
2	Operating Modes and States	6
2.1	Uncalibrated and Calibrated Mode	6
2.2	Adaptive Hysteresis	7
2.3	Direction Detection	8
2.4	Vibration Suppression	8
2.5	Undervoltage Behavior	8
3	Absolute Maximum Ratings	9
4	ESD Robustness	9
5	Operating Range	10
6	Electrical Characteristics	11
7	Timing Characteristics	12
8	Electromagnetic Compatibility	14
9	Package Information	16

Functional Description

1 Functional Description

The differential Hall sensor IC detects the motion of tooth and magnet encoder applications. To detect the motion of ferromagnetic objects, the magnetic field must be provided by a back biasing permanent magnet. Either south or north pole of the magnet can be attached to the rear unmarked side of the IC package.

The magnetic measurement is based on three equally spaced Hall elements, integrated on the IC.

Both magnetic and mechanical offsets are cancelled by a self calibration algorithm.

The sensor includes a current output PWM protocol.

1.1 Sensor Assembly

The output signals for a south biased sensor with a magnetic encoder and ferromagnetic tooth wheel will be issued in the following way.

The tooth wheel is rotating in clockwise above the sensor. The output pulse will be issued by reaching the hysteresis levels after the pre low time. For a tooth wheel with ideal pitch (tooth to tooth) of 5 mm the direction signal achieves a phase shift of 90° compared to the speed signal.

Sensor and back bias magnet can be applied in the following ways:

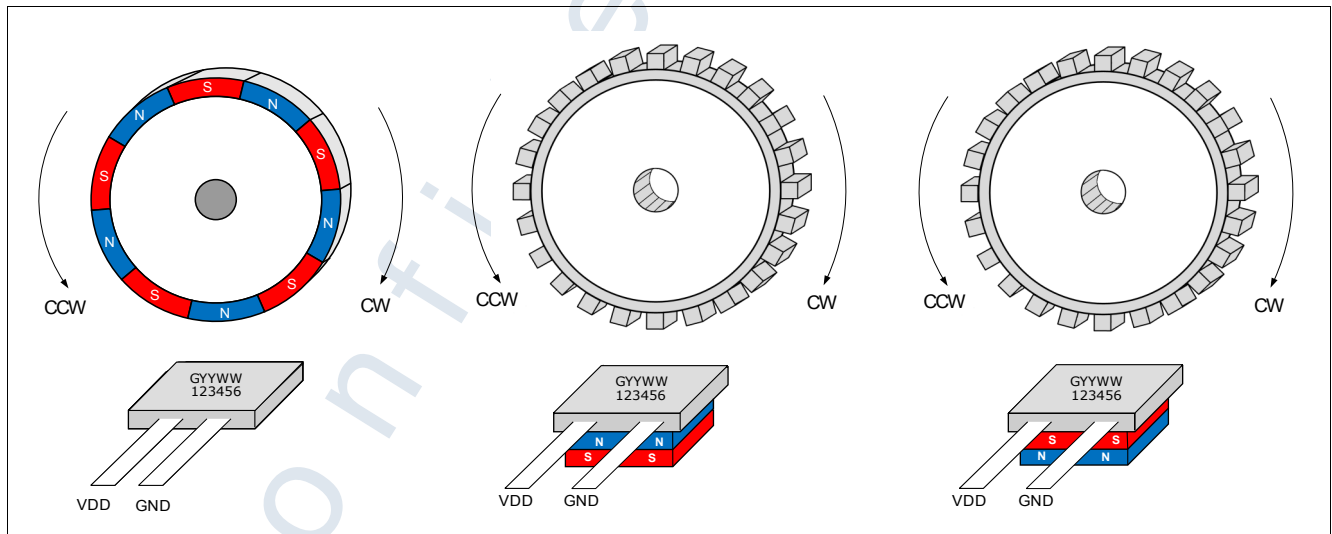

Figure 1 Sensor Assembly and Definition of Rotating Directions

Functional Description

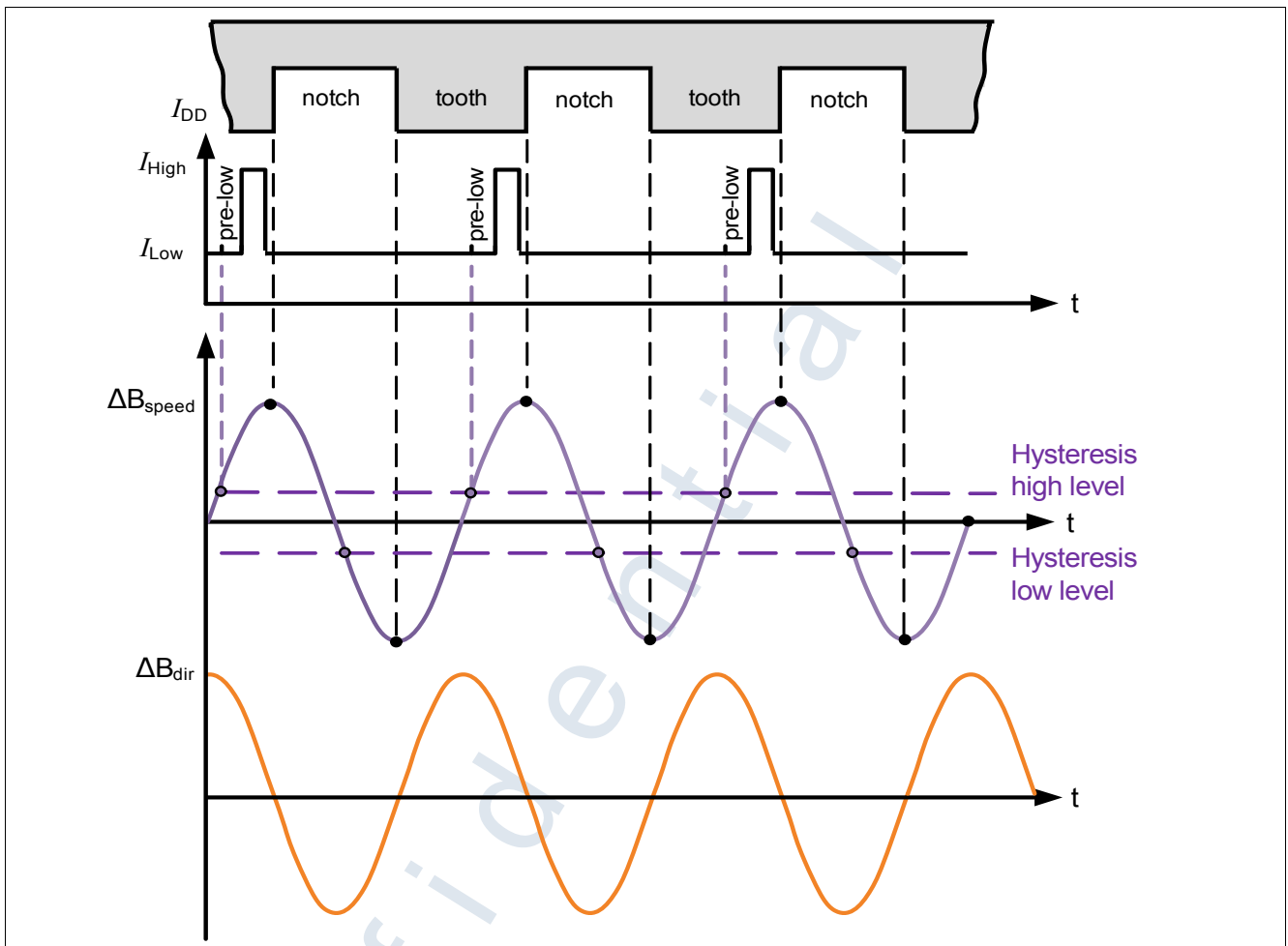

Figure 2 Tooth Wheel vs. Sensor Output Signal in Clockwise Rotation; South Biased Sensor

Functional Description

1.2 Block Diagram

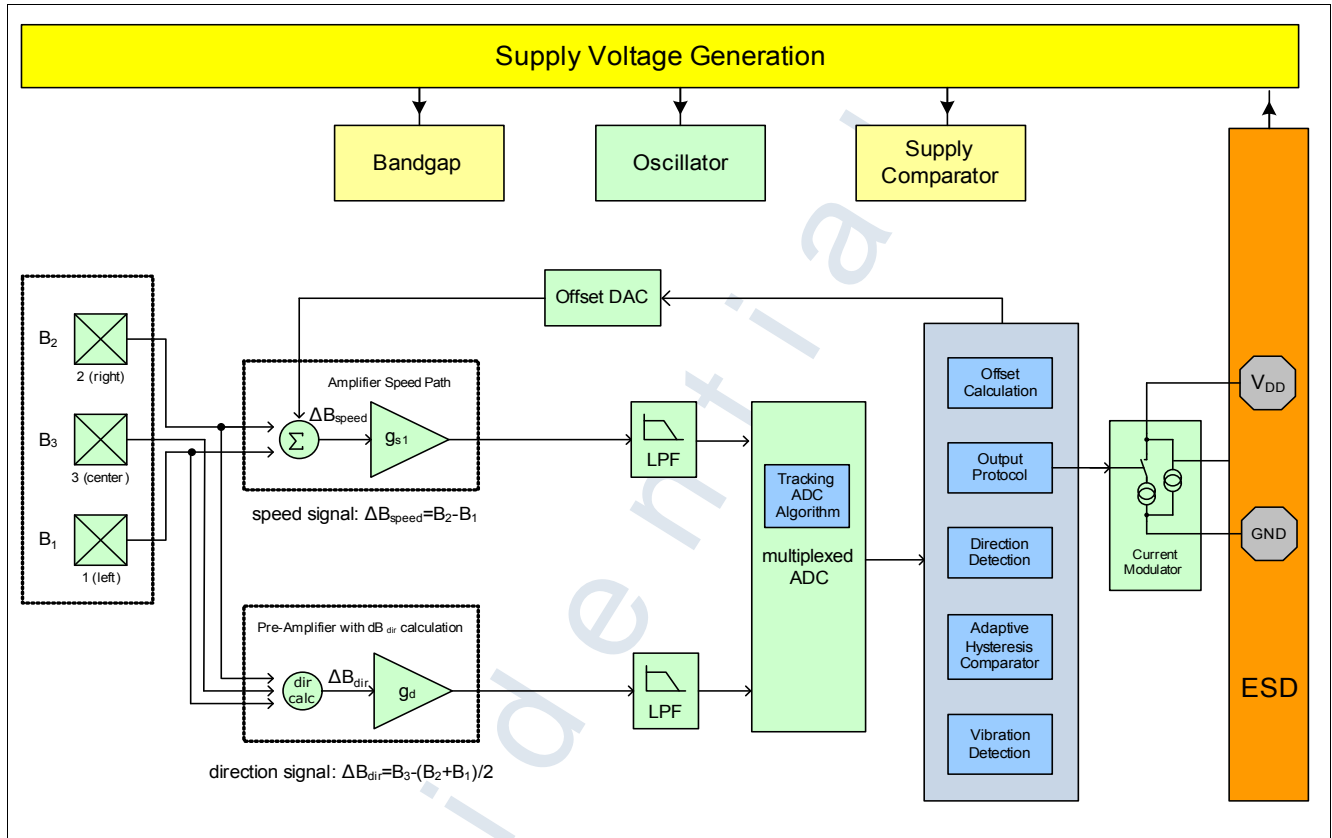

Figure 3 Block Diagram

The speed signal calculated out of $B_2 - B_1$, is amplified, low pass filtered and digitized. An algorithm in the digital core for peak detection and offset calculation will be executed. The offset is fed back into the speed signal path with a digital to analog converter for offset correction. The adaptive hysteresis comparator compares the speed signal to the hysteresis value. During uncalibrated mode, the output of the speed pulse is triggered in the digital core by exceeding a certain threshold.

The direction signal is calculated out of the three Hall signals. The direction signal is amplified, filtered, and digitized. In the digital core the direction and the vibration detection information is determined and the data protocol is issued. The direction information is converted to a current modulated signal.

2 Operating Modes and States

2.1 Uncalibrated and Calibrated Mode

After power on the differential magnetic speed signal is tracked by an analog to digital converter (Tracking ADC) and monitored within the digital core. If the signal slope is identified as a rising edge, the first output pulse is triggered. A second trigger pulse is issued as soon as the next rising edge is detected (see **Figure 4**). In uncalibrated mode, the output protocols are triggered by the DNC (detection noise constant) in the speed path. After start up the first DNC value is set to $2 \times \Delta B_{\text{speed-limit}}$ and after that the DNC is adapted to the magnetic input signal amplitude (ΔB_{speed}) with a minimum of $2 \times \Delta B_{\text{speed-limit}}$.

The offset update starts if two valid extrema values are found and the direction of the update has the same orientation as the magnetic signal. For example, a positive offset update is being issued on a rising magnetic edge only. The offset update is done independent from the output switching. After a successful offset correction, the sensor is in calibrated mode. Switching occurs at the adaptive hysteresis threshold level.

In calibrated mode, the DNC is adapted to magnetic input signal amplitude (as $\Delta B_{\text{speed}}/2$) with a minimum of $2 \times \Delta B_{\text{speed-limit}}$. The output pulses are then triggered with adaptive hysteresis.

In uncalibrated mode (after start-up or reset) for signals with amplitude smaller than $2 \times \Delta B_{\text{limit}}$ (either for direction or speed signal), the sensor always provides the first two pulses and could suppress the third one. The pulse corresponding to the fourth magnetic period is calibrated, thus including the direction information.

Operating Modes and States

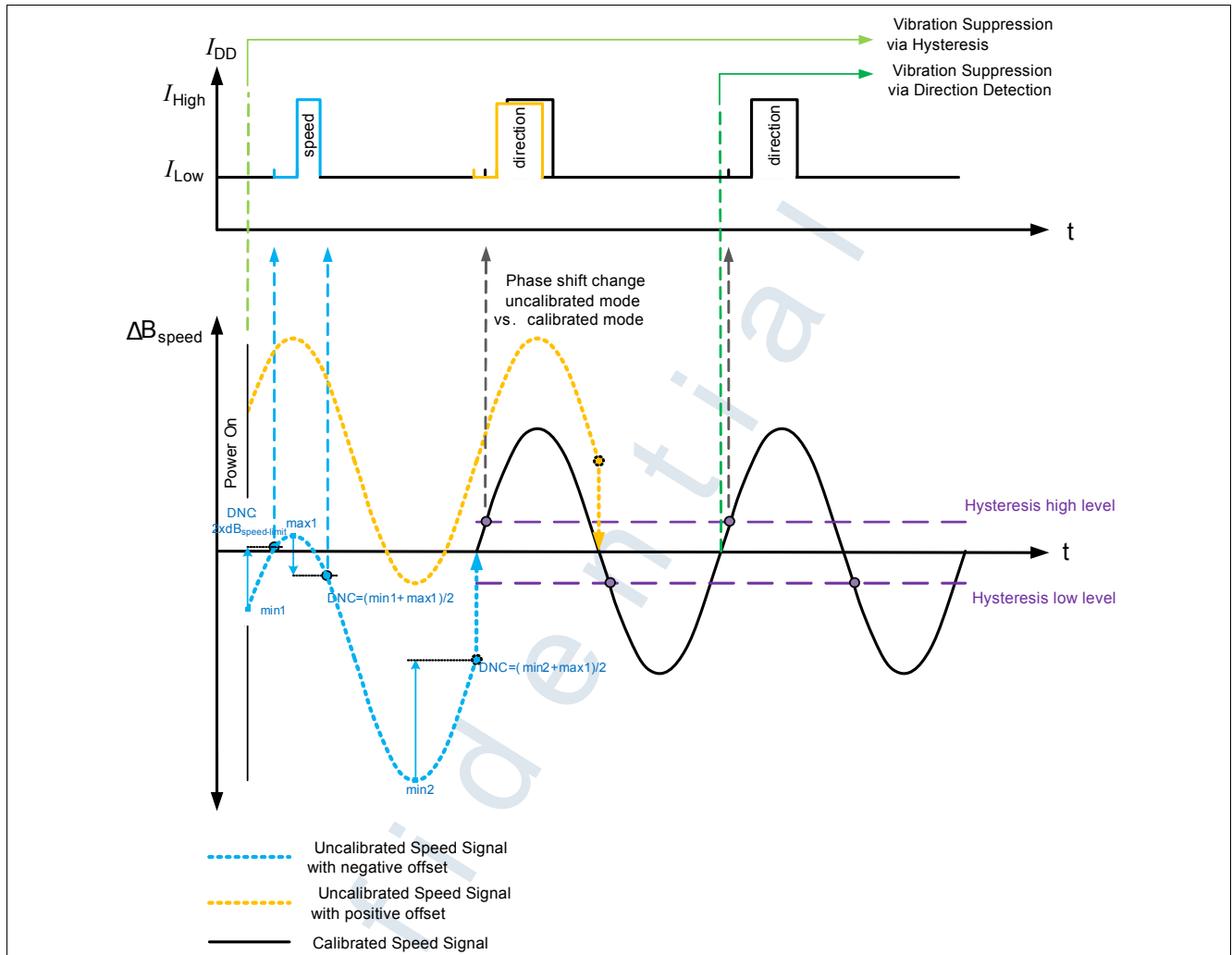

Figure 4 Example for Startup Behavior and Transition from Uncalibrated into Calibrated Mode

2.2 Adaptive Hysteresis

The adaptive hysteresis is linked to the input signal. Therefore, the system is able to suppress switching if vibration or noise signals are smaller than the adaptive hysteresis levels. The typical value for the hysteresis level is 1/8 of the magnetic input signal amplitude, the minimum hysteresis level is $\Delta B_{speed-limit}$ (amplitude). The visible hysteresis keeps the excellent performance in large pitch transmission application wheels.

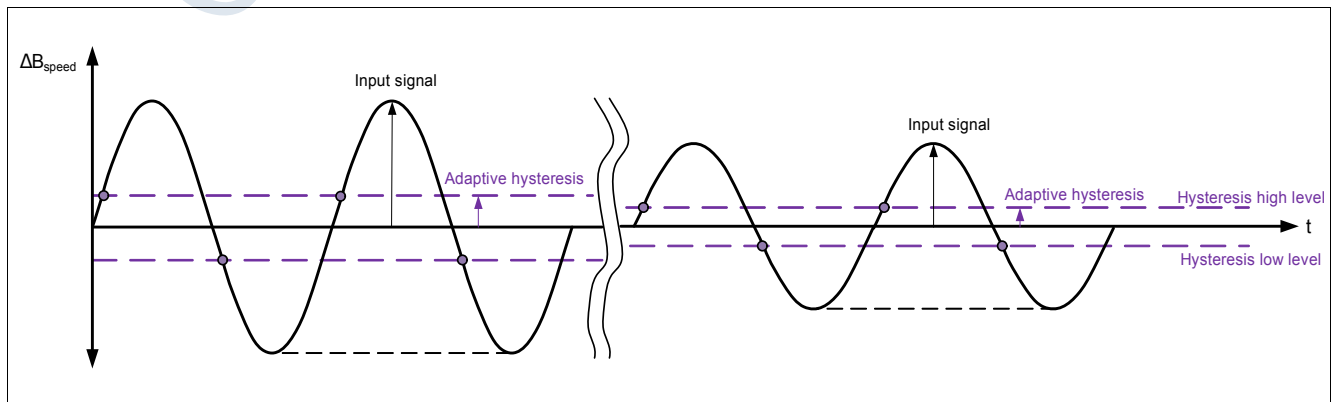

Figure 5 Adaptive Hysteresis

Operating Modes and States

2.3 Direction Detection

The difference between the Hall element signal B_3 and the mean value of the outer Hall elements B_2 and B_1 will be calculated in the direction input amplifier. This signal is digitized by an analog to digital converter (direction ADC) and fed into the digital core.

Depending upon the rotation direction of the target wheel, the signal of the center probe anticipates or lags behind for 90° . This phase relationship is evaluated and converted into rotation direction information by sampling the signal of the center probe in the proximity of the zero crossing of the “speed” bridge signal.

The first pulse after power on is a speed pulse, as there is no valid direction information available.

2.4 Vibration Suppression

The magnetic signal amplitude and the direction information are used for detection of parasitic magnetic signals. Unwanted magnetic signal can be caused by angular or air gap vibrations. If an input signal is identified as a vibration the output pulse will be suppressed.

TLE4955C offers two different kinds of vibration suppression:

- Vibration suppression via hysteresis. This is available after power on
- Vibration suppression via direction detection. This is available after start up calibration is performed.

2.5 Undervoltage Behavior

At the first switching events after power on the undervoltage detection is activated.

If the supply voltage drops below the values specified in operating range, an active output (defined state) will be generated. The output level is switched to high current (I_{High}) and it remains at this level until the supply voltage reaches again the functional level.

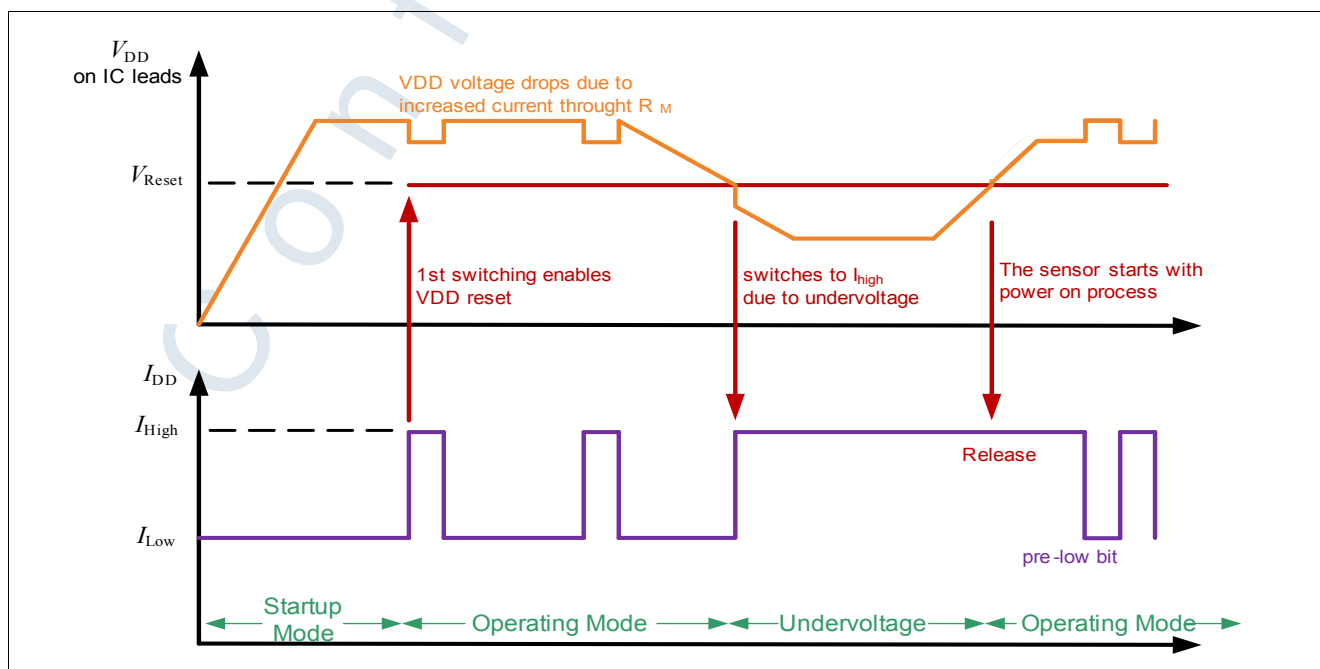

Figure 6 Undervoltage Behavior

If the supply voltage is below 2.3 V typical the sensor will reset and initiate a new calibration.

Absolute Maximum Ratings

3 Absolute Maximum Ratings

Attention: Stresses above the max. values listed here may cause permanent damage to the device. Exposure to absolute maximum rating conditions for extended periods may affect device reliability. Maximum ratings are absolute ratings; exceeding only one of these values may cause irreversible damage to the integrated circuit

Table 1 Absolute Maximum Ratings

Parameter	Symbol	Values			Unit	Note or Test Condition
		Min.	Typ.	Max.		
Supply voltage	V_{DD}	-0.3			V	$T_j < 80\text{ }^\circ\text{C}$
				16.5	V	$T_j = 170\text{ }^\circ\text{C}$
				20	V	$T_j = 150\text{ }^\circ\text{C}$
				22	V	$t = 10 \times 5\text{ min.}$
				24	V	$t = 10 \times 5\text{ min.}; R_M \geq 75\ \Omega$
				27	V	$t = 400\text{ms}, R_M \geq 75\ \Omega,$
		-22			V	$R_M = 75\ \Omega, t < 1\text{ h}$
Junction temperature	T_j ; Either	-40		110	$^\circ\text{C}$	12500 h
	or			125	$^\circ\text{C}$	10000 h
	or			150	$^\circ\text{C}$	5000 h
	or			160	$^\circ\text{C}$	2500 h
	or			170	$^\circ\text{C}$	500 h
	additional			190	$^\circ\text{C}$	4 h, $V_{DD} < 16.5\text{ V}$
Reverse polarity current	I_{DD}	-200			mA	External current limitation required, $t < 4\text{ h}$
		-300			mA	External current limitation required, $t < 1\text{ h}$
		-200			mA	External current limitation required, $t < 10\text{ h}, T_j = 25\text{ }^\circ\text{C}$
Thermal resistance (PG-SSO-2-53)	R_{thJA}			190	K/W	Lower values are possible with overmolded devices
Number of power on cycles	n	500000			cycles	

4 ESD Robustness

Characterized according to Human Body Model (HBM) test in compliance with standard EIA/JESD22-A114-B HBM (covers MIL STD 883D)

Table 2 ESD Protection

Parameter	Symbol	Test Result	Unit	Note
ESD-Protection	V_{ESD}	± 12	kV	$R = 1.5\text{ k}\Omega, C = 100\text{ pF}$

Operating Range

5 Operating Range

All parameters specified in the following sections refer to these operating conditions unless otherwise noticed. For further details please refer also to any relevant Application Notes.

Table 3 Operating Range

Parameter	Symbol	Values			Unit	Note or Test Condition	
		Min.	Typ.	Max.			
Supply voltage	V_{DDIC}	4		20	V	Directly on the IC leads	
Supply voltage modulation	V_{AC}			6	V	$V_{DD} = 13\text{ V}$; $0 < f_{mod} < 150\text{ kHz}^{1)}$ peak-to-peak	
Operating junction temperature	T_j						
	either	-40		110	°C	12500 h	
	or			125	°C	10000 h	
	or			150	°C	5000 h	
	or			160	°C	2500 h	
Operating junction temperature	or			170	°C	500 h	
	Junction temperature variation between two consecutive magnetic edges ³⁾	T_{j_var}	-60		60	K	Values apply for ΔB_{speed} and $\Delta B_{dir} > 2.5\text{ mT}$ (amplitude) in calibrated mode. In case of uncalibrated sensor, values apply for ΔB_{speed} and $\Delta B_{dir} > 7.5\text{ mT}$ (amplitude).
	Frequency range of magnetic input signal ²⁾	f	0		12	kHz	
	Bias-induction ³⁾	B_o	-500		+500	mT	Magnetic bias induction at the position of each sensing element (B_1, B_2, B_3)
	Differential bias-induction ³⁾	$\Delta B_{stat\ l/r}$	-30		+30	mT	Difference of the magnetic bias induction between left (B_1) and right (B_2) sensing element
Differential bias-induction between mean value at left, right and center sensing elements ³⁾	$\Delta B_{stat\ m/o}$	-30		+30	mT	Difference of the magnetic bias induction between $(B_2+B_1)/2$ and B_3	
Speed signal range	$\Delta B_{speed,range}$	-120		120	mT		
Minimum speed signal	$\Delta B_{speed-limit}$	0.6	1.1	2.0	mT	Amplitude value, 99% criteria ⁴⁾	
Minimum direction signal	$\Delta B_{dir-limit}$	0.1	0.18	0.36	mT	Amplitude value, 99% criteria ³⁾⁴⁾	

- 1) Sine wave.
- 2) No time based watchdog.
- 3) Not subject to production test, verified by design/characterization.
- 4) 99% criterion stands for 1 out of 100 pulses is missing.

Note: Magnetic parameters are valid for sinusoidal signals and characterized for $f > 1\text{ Hz}$.

Electrical Characteristics

6 Electrical Characteristics

All values specified at constant amplitude and offset of input signal, over operating range, unless otherwise specified. Typical values correspond to $V_{DD} = 12\text{ V}$ and $T_j = 25\text{ °C}$.

Table 4 Electrical Characteristics

Parameter	Symbol	Values			Unit	Note or Test Condition
		Min.	Typ.	Max.		
Supply current low	I_{Low}	6	7	8	mA	
Supply current high	I_{High}	12	14	16	mA	
Supply current ratio	I_{High}/I_{Low}	1.9		2.2		
Output rise/fall slew rate	SR_r, SR_f	8	17	26	mA/ μ s	Valid for t_r and t_f , between 10% and 90% value $R_M=75\ \Omega$, $T_j<175\text{ °C}$
Reset voltage	$V_{DD\ Reset}$		3.7	4	V	
Power on time ¹⁾	t_{ON}			1	ms	$V_{DD} > 4\text{ V}$
Magnetic edges required for first output pulse ¹⁾	n_{start}			2	magn. edge	No vibration, pulse occurs only on rising magnetic edge
Number of output pulse until active vibration suppression via hysteresis ¹⁾	$n_{VH-Startup}$			0	pulse	Active after power on
Number of output pulse until active vibration suppression via direction detection ¹⁾	$n_{VD-Startup}$			2	pulse	vibration suppression activated with complete 3 rd magnetic signal period
Number of magnetic periods generating missing output pulses or pulse without direction information ¹⁾	$n_{DR-Start}$			1	pulse	$\Delta B_{dir} \geq 2 * \Delta B_{dir-limit}$ and $\Delta B_{speed} \geq 2 * \Delta B_{speed-limit}$
				3	pulse	$\Delta B_{dir-limit} < \Delta B_{dir} < 2 * \Delta B_{dir-limit}$ or $\Delta B_{speed-limit} < \Delta B_{speed} < 2 * \Delta B_{speed-limit}$ ²⁾
Invalid direction after change of direction ¹⁾	n_{IAC}			1	pulse	2 nd pulse correct if $\Delta B_{dir} \geq \Delta B_{dir-limit}$
Period Jitter ¹⁾ , $f \leq 2500\text{ Hz}$	$S_{Jit-far}$, $T_j \leq 150\text{ °C}$			± 1.6	%	1σ value ³⁾ , $V_{DD}=12\text{ V}$, $\Delta B_{speed} \geq 2\text{ mT}$ (amplitude)
				± 2.4	%	
Period Jitter ¹⁾ , $2500\text{ Hz} < f < 12\text{ kHz}$	$S_{Jit-far}$, $T_j \leq 150\text{ °C}$			± 2.7	%	1σ value ⁵⁾ , $V_{DD}=12\text{ V}$, $\Delta B_{speed} \geq 2\text{ mT}$ (amplitude)
				± 4.0	%	
Period Jitter at board net ripple ¹⁾	S_{Jit-AC}			± 2.0	%	$V_{CC} = 13\text{ V} \pm 3\text{ V}_{pp}$; 1σ ; $0 < f_{mod} < 150\text{ kHz}$; $\Delta B_{speed} = 7.5\text{ mT}$

1) Not subject to production test, verified by design/characterization.

2) Either condition or both simultaneously need to be applied.

3) Values based on 3σ measurements.

Timing Characteristics

7 Timing Characteristics

Between each magnetic transition and the rising edge of the corresponding output pulse, the output current is low for $t_{pre-low}$ in order to allow reliable internal conveyance. After pre low time the output current level is set to high.

After power on the speed pulse is being issued. As soon as the sensor has enough information to recognize the direction of the target wheel, the output pulse will include the direction information.

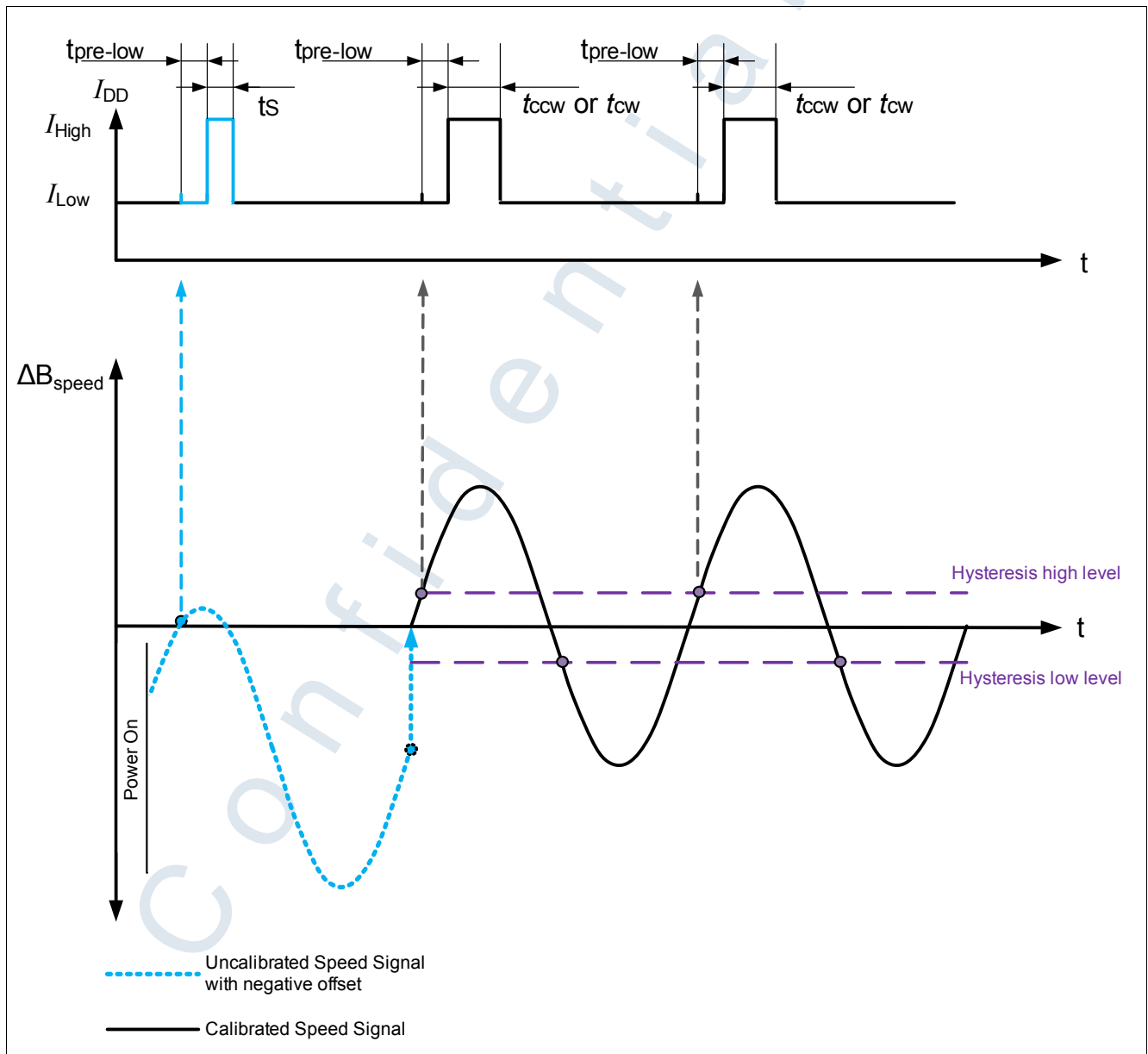

Figure 7 Definition of PWM Current Interface

Timing Characteristics

Table 5 Timing Characteristics

Parameter	Symbol	Values			Unit	Note or Test Condition
		Min.	Typ.	Max.		
Pre-low length	$t_{pre-low}$	26.25	30	33.75	μs	
Length of speed pulse	t_s	26.25	30	33.75	μs	
Length of CCW pulse	t_{CCW}	52.5	60	67.5	μs	
Length of CW pulse	t_{CW}	105	120	135	μs	
CW / CCW pulse maximum frequency	f_{DR_max}	1000			Hz	
speed pulses maximum frequency	f_{ts}	12000			Hz	

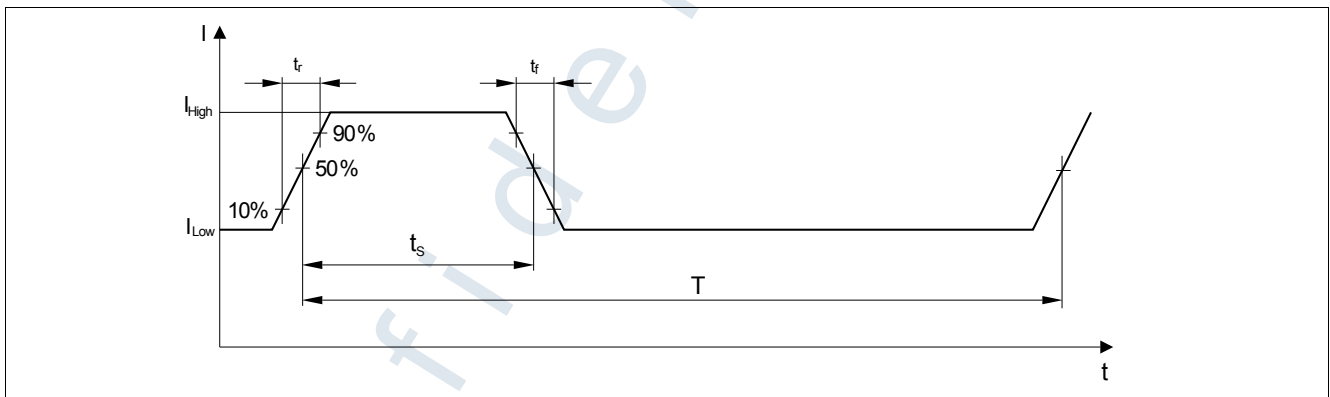

Figure 8 Definition of Rise and Fall time; Duty Cycle= $(t_s / T) \times 100\%$

Electromagnetic Compatibility

8 Electromagnetic Compatibility

Electromagnetic Compatibility (values depends on R_M !). See Figure 9

Note: Characterization of Electro Magnetic Compatibility is carried out on samples based on one qualification lot. Not all specification parameters have been monitored during EMC exposure. Only key parameters e.g. switching current have been monitored.

Table 6 Conducted Pulses

REF. ISO 7637-2; 2004; $\Delta B_{\text{speed}} = 2 \text{ mT}$ (amplitude of sinus signal); $V_{\text{DD}} = 13.5\text{V}$; $f_B = 100 \text{ Hz}$; $T_j = 25 \text{ }^\circ\text{C}$; $R_M = 75 \text{ } \Omega$

Parameter	Symbol	Level/Type	Status
Testpulse 1	V_{EMC}	IV / -100 V	C
Testpulse 2a ¹⁾		IV / 75 V	A ²⁾
Testpulse 2b		- / 10 V	C ³⁾
Testpulse 3a		IV / -150 V	A
Testpulse 3b		IV / 100 V	A
Testpulse 4 ⁴⁾		IV / -7 V	C
Testpulse 5a		IV / 86.5 V	C
Testpulse 5b		$U_s^* = 28.5 \text{ V}^{5)}$	C

- 1) ISO 7637-2 describes internal resistance = 2 Ω (former 10 Ω)
- 2) Node A does not exceed 27 V clamping voltage of D2 in any case; Design target!
- 3) $R_i = 0.01 \text{ } \Omega$
- 4) Testpulse4 tested for $V_{\text{DD}} = 12 \text{ V}$
- 5) A central load dump protection of 42 V is used. $U_s^* = 42 \text{ V} - 13.5 \text{ V}$

Table 7 Coupled Pulses

REF. ISO 7637-3; 1995; $\Delta B_{\text{speed}} = 2 \text{ mT}$ (amplitude of sinus signal);
 $V_{\text{DD}} = 13.5 \text{ V}$; $f_B = 100 \text{ Hz}$; $T_j = 25 \text{ }^\circ\text{C}$; $R_M = 75 \text{ } \Omega$

Parameter	Symbol	Level/Typ	Status
Testpulse 3a		IV / -60 V	A
Testpulse 3b		IV / 40 V	A

Table 8 TEM-cell measurement

REF. ISO 11452-3, 2nd edition 2001-03-01; measured in TEM-cell; $\Delta B_{\text{speed}} = 2 \text{ mT}$ (amplitude of sinus signal)
 $V_{\text{DD}} = 13.5 \text{ V}$; $f_B = 100 \text{ Hz}$; $T = 25 \text{ }^\circ\text{C}$; $R_M = 75 \text{ } \Omega$

Parameter	Symbol	Level/Typ	Status
	E_{TemCell}	IV / 250 V/m	CW; AM=80%, f=1 kHz

Electromagnetic Compatibility

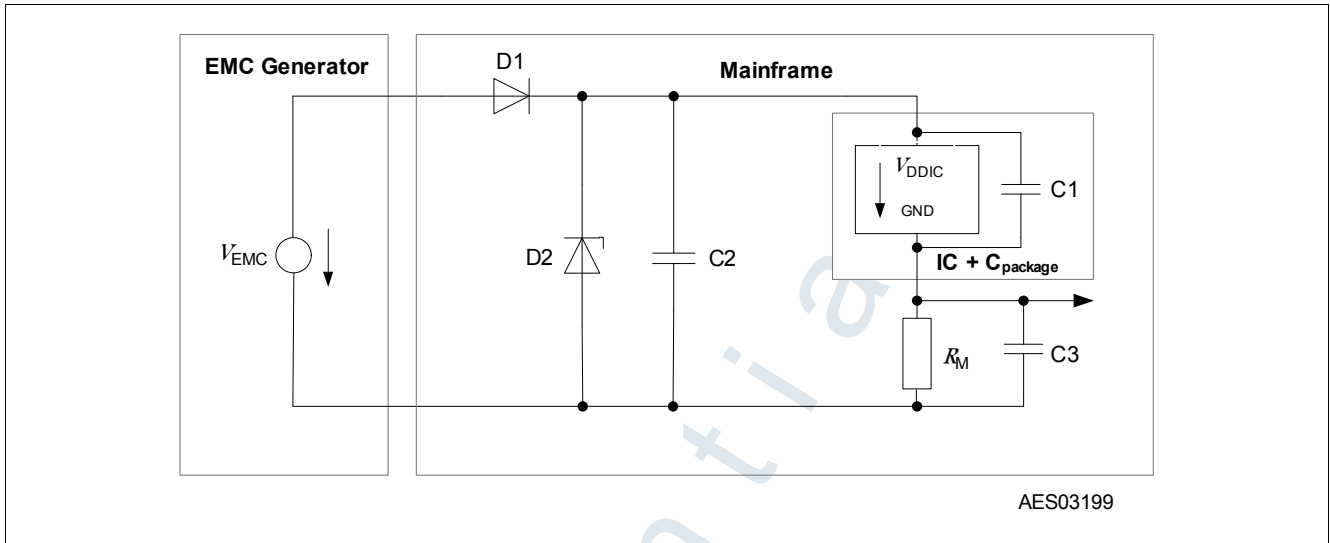

Figure 9 EMC test circuit

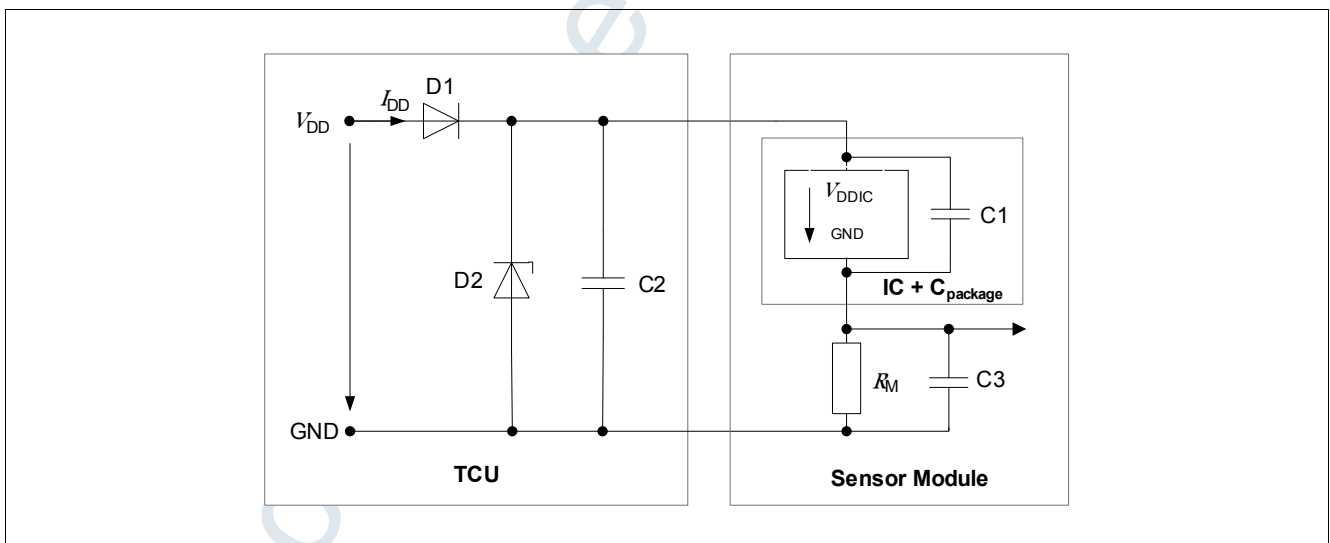

Figure 10 Application circuit

Components

D1= 1N4007

D2= 27 V

C1= 1.8nF / 50 V

C2= 10 μ F / 35 V

C3= 1 nF / 1000 V

R_M = 75 Ω

Package Information

9 Package Information

Pure tin covering (green lead plating) is used. Lead frame material is copper based, e.g. K62. (UNS:C18090) and contains CuSn1CrNiTi. Product is RoHS (Restriction of hazardous Substances) compliant and marked with the letter G in front of the data code marking and may contain a data matrix code on the rear side of the package (see also information note 136/03). Please refer to your key account team or regional sales if you need further information.

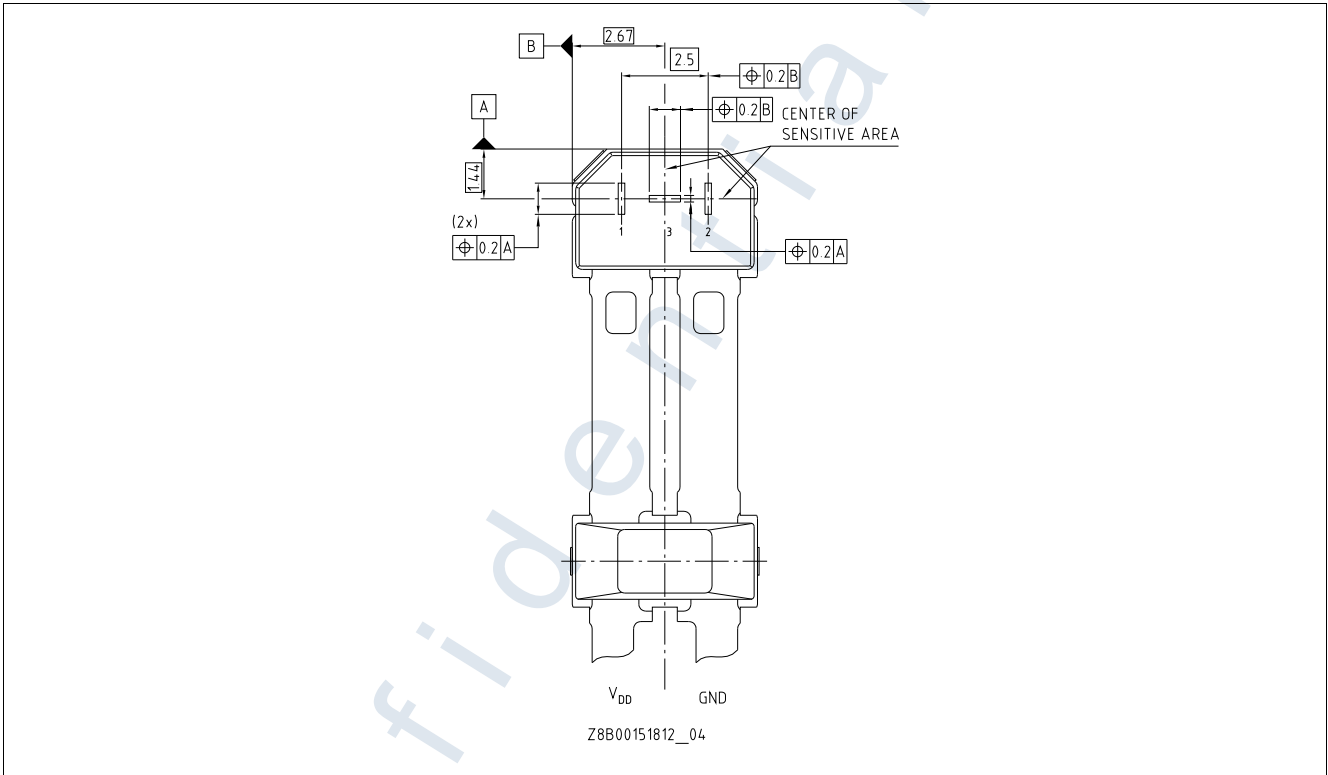

Figure 11 Pin configuration and sensitive area (view on front side with marking of component)

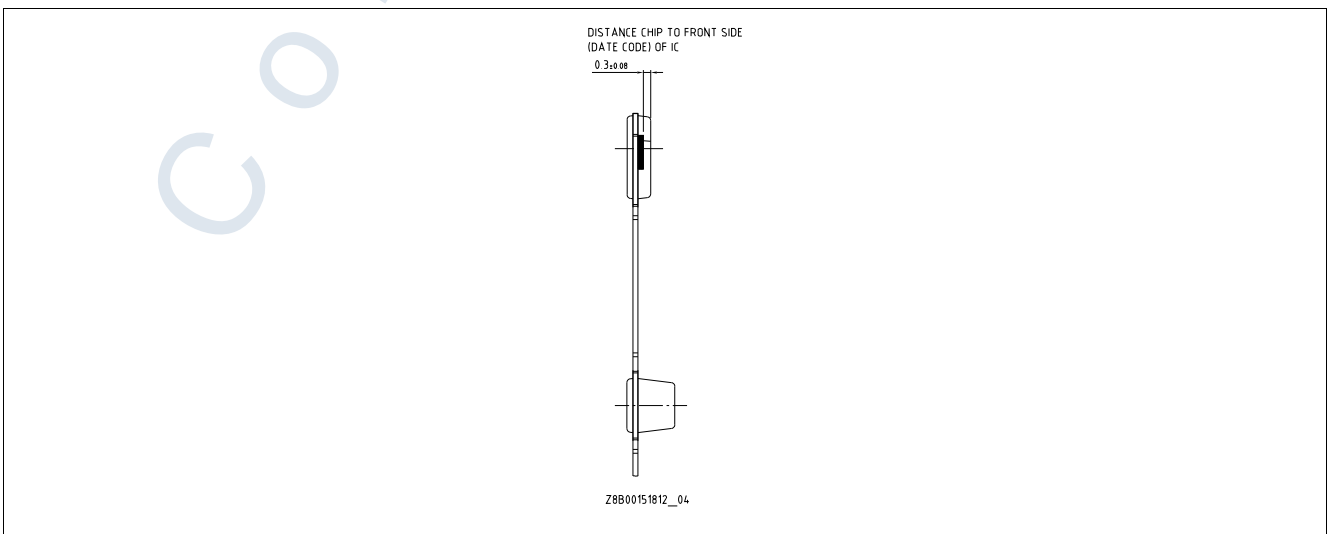

Figure 12 Distance of the chip to the upper package edge

Package Information

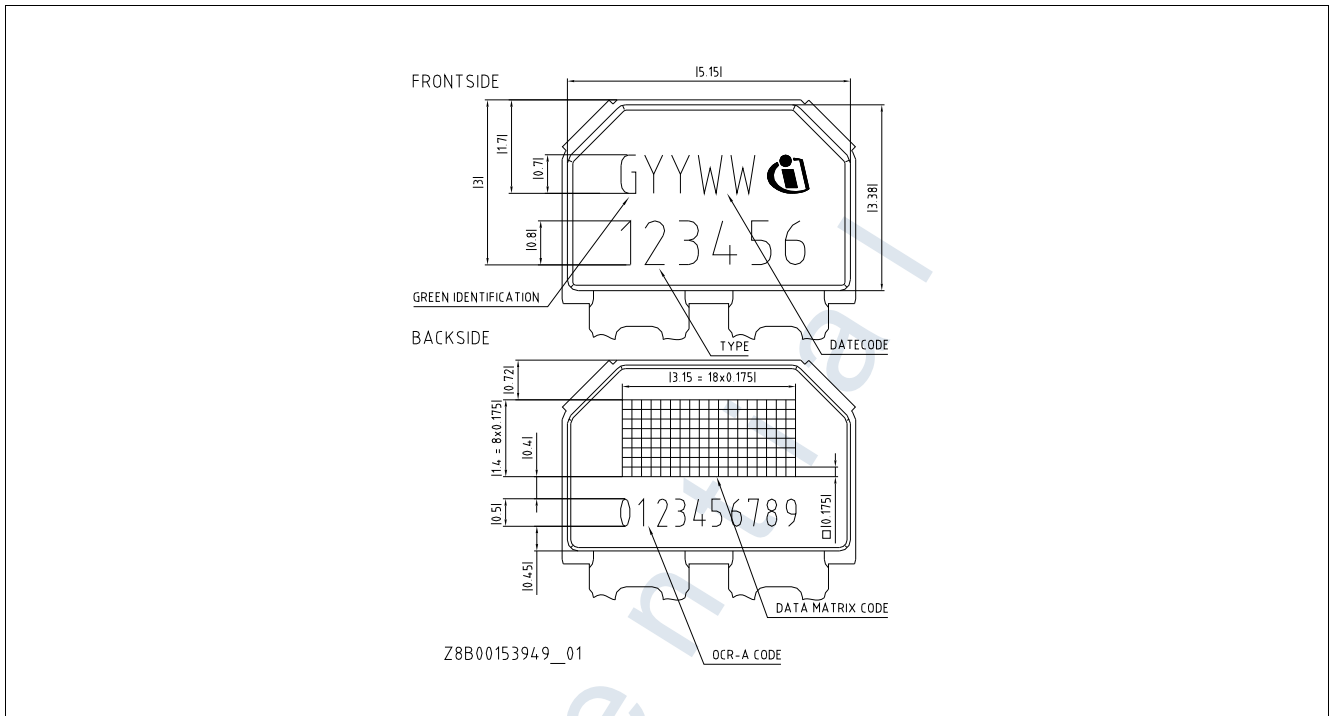

Figure 15 Marking of PG-SSO-2-53

Table 9 Marking Description

GYYWW		123456
G	Green package	55BIC0
YY	Production year	
WW	Production week	

For additional packages information, sort of packing and others, please see Infineon internet web page <http://www.infineon.com/products>

Revision History

Page or Item	Subjects (major changes since previous revision)
	First version of released datasheet

Trademarks of Infineon Technologies AG

AURIX™, C166™, CanPAK™, CIPOS™, CoolGaN™, CoolMOS™, CoolSET™, CoolSiC™, CORECONTROL™, CROSSAVE™, DAVE™, DI-POL™, DrBlade™, EasyPIM™, EconoBRIDGE™, EconoDUAL™, EconoPACK™, EconoPIM™, EiceDRIVER™, eupec™, FCOS™, HITFET™, HybridPACK™, Infineon™, ISOFACE™, IsoPACK™, i-Wafer™, MIPAQ™, ModSTACK™, my-d™, NovalithIC™, OmniTune™, OPTIGA™, OptiMOS™, ORIGA™, POWERCODE™, PRIMARION™, PrimePACK™, PrimeSTACK™, PROFET™, PRO-SIL™, RASIC™, REAL3™, ReverSave™, SatRIC™, SIEGET™, SiPMOS™, SmartLEWIS™, SOLID FLASH™, SPOC™, TEMPFET™, thinQ!™, TRENCHSTOP™, TriCore™.

Trademarks updated August 2015

Other Trademarks

All referenced product or service names and trademarks are the property of their respective owners.

Edition 2016-06-15

Published by

Infineon Technologies AG

81726 Munich, Germany

© 2016 Infineon Technologies AG.

All Rights Reserved.

Do you have a question about any aspect of this document?

Email: erratum@infineon.com

Document reference

IMPORTANT NOTICE

The information given in this document shall in no event be regarded as a guarantee of conditions or characteristics ("Beschaffenhheitsgarantie").

With respect to any examples, hints or any typical values stated herein and/or any information regarding the application of the product, Infineon Technologies hereby disclaims any and all warranties and liabilities of any kind, including without limitation warranties of non-infringement of intellectual property rights of any third party.

In addition, any information given in this document is subject to customer's compliance with its obligations stated in this document and any applicable legal requirements, norms and standards concerning customer's products and any use of the product of Infineon Technologies in customer's applications.

The data contained in this document is exclusively intended for technically trained staff. It is the responsibility of customer's technical departments to evaluate the suitability of the product for the intended application and the completeness of the product information given in this document with respect to such application.

For further information on technology, delivery terms and conditions and prices, please contact the nearest Infineon Technologies Office (www.infineon.com).

WARNINGS

Due to technical requirements products may contain dangerous substances. For information on the types in question please contact your nearest Infineon Technologies office.

Except as otherwise explicitly approved by Infineon Technologies in a written document signed by authorized representatives of Infineon Technologies, Infineon Technologies' products may not be used in any applications where a failure of the product or any consequences of the use thereof can reasonably be expected to result in personal injury.

单击下面可查看定价，库存，交付和生命周期等信息

[>>Infineon Technologies\(英飞凌\)](#)