

NUMBER  
C-1734742

3RD ANGLE PROJECTION

METRIC

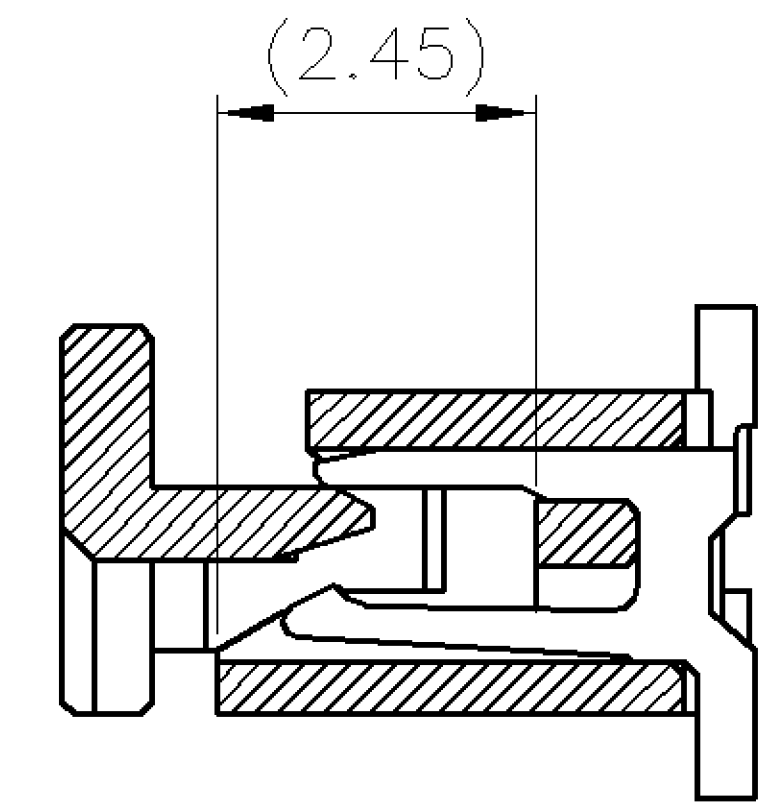
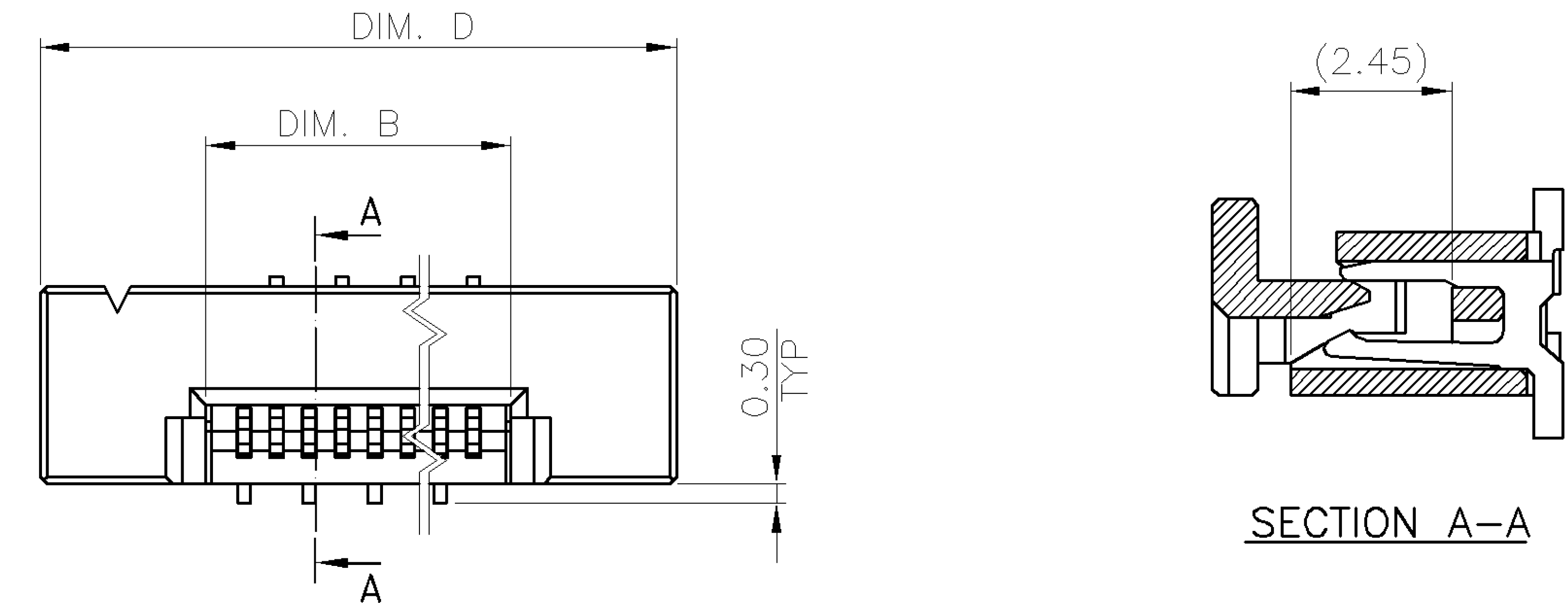

SECTION A-A

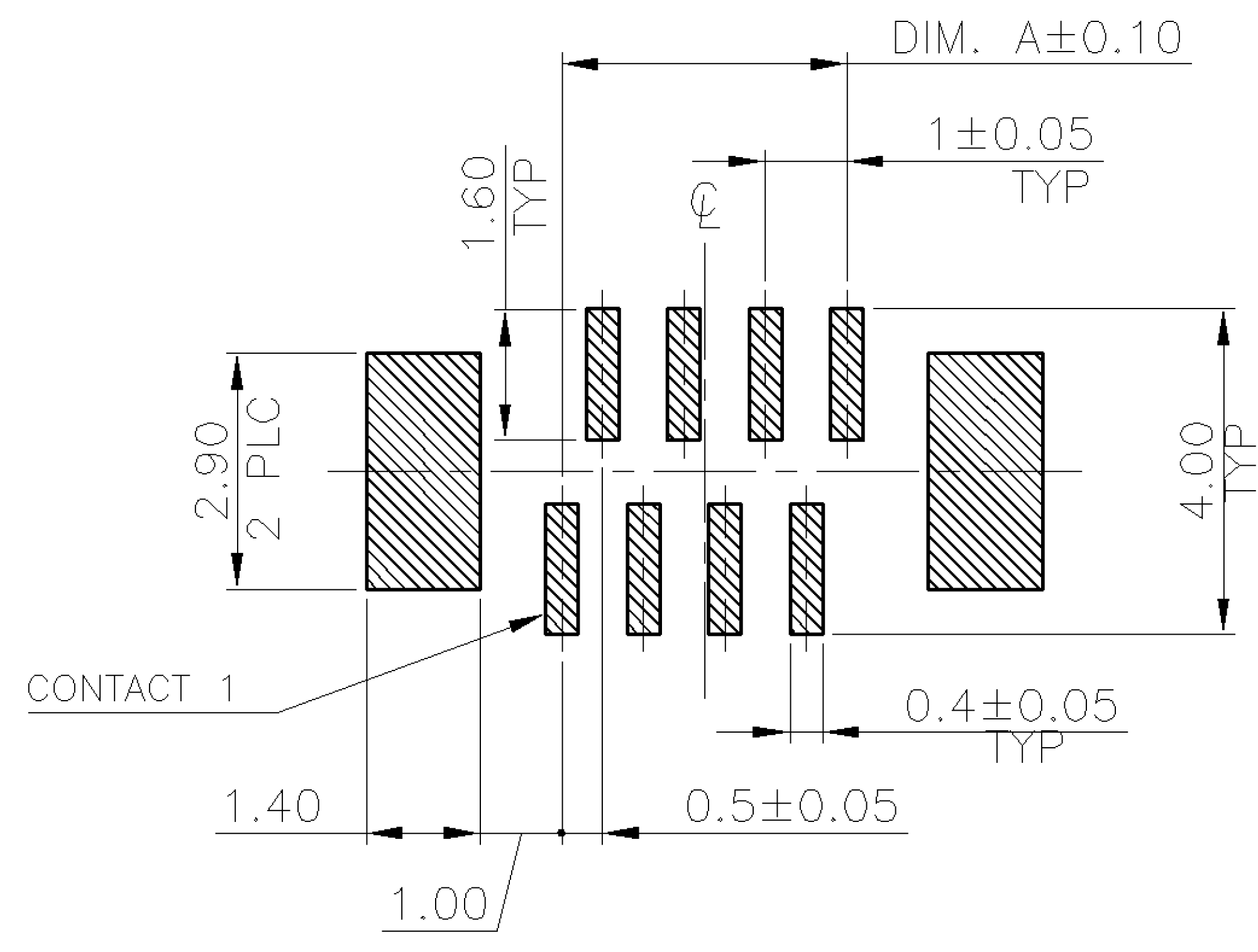
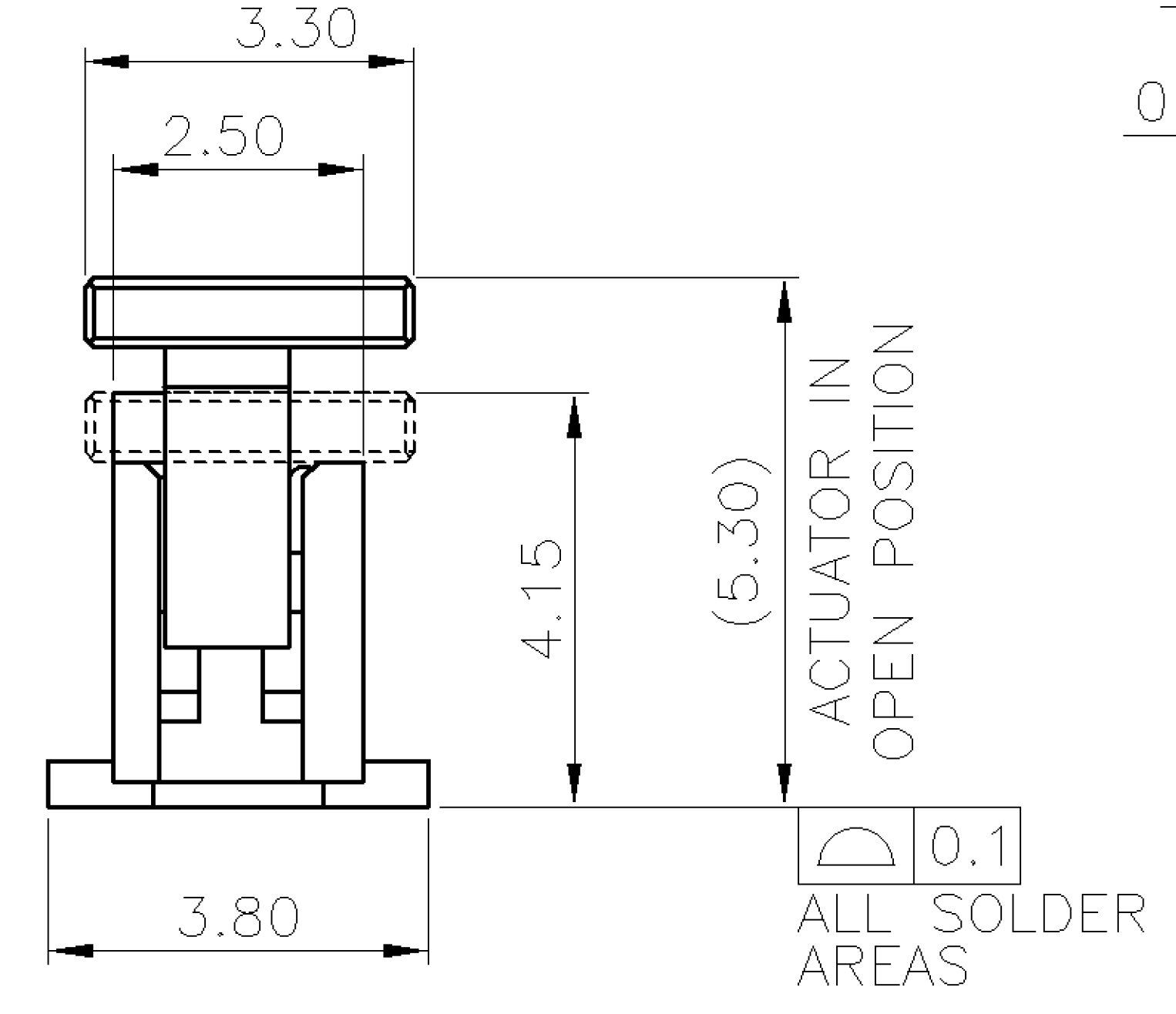
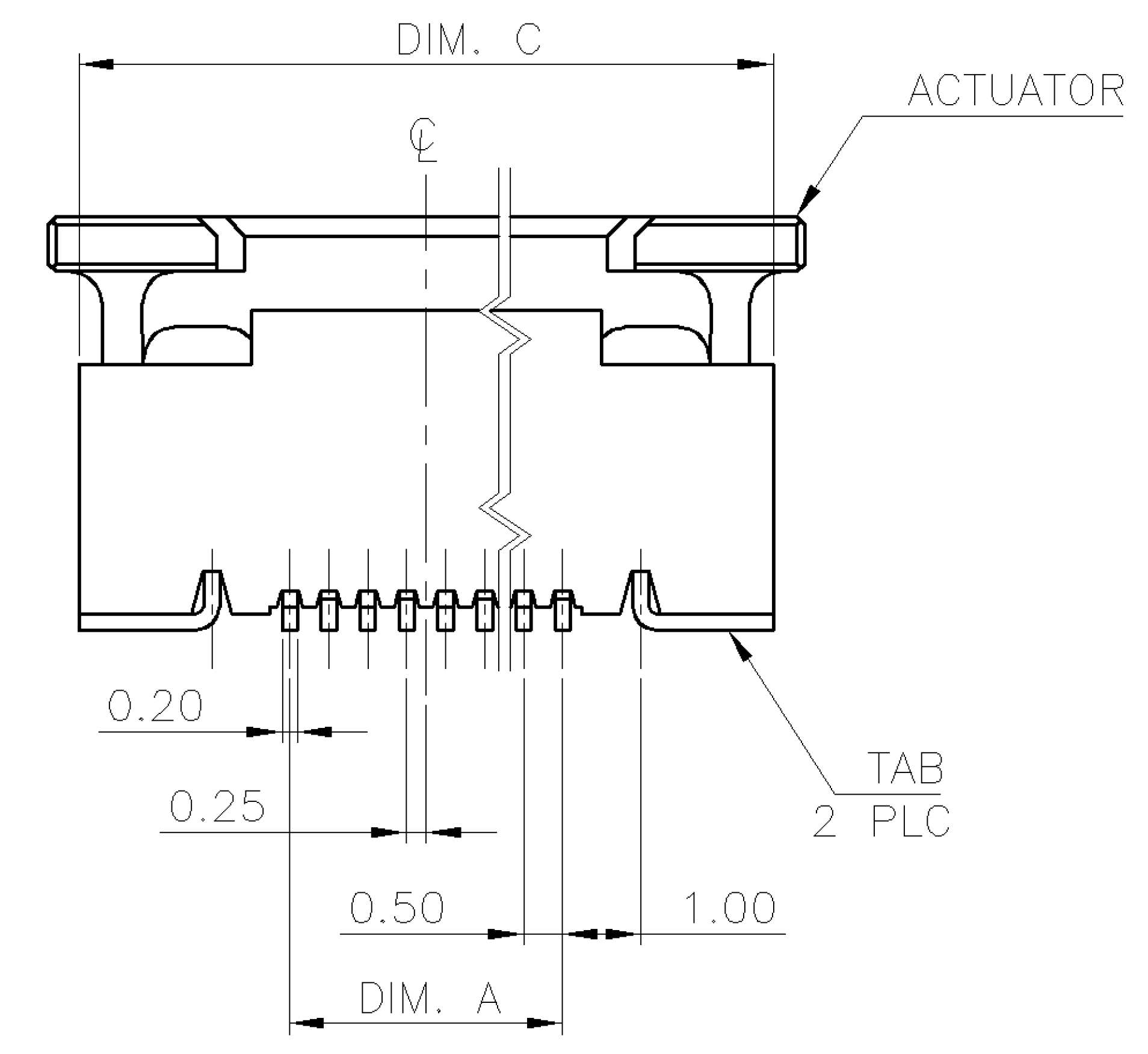

RECOMMENDED PCB LAYOUT (TYPE A)  
(TOLERANCE: ±0.05)

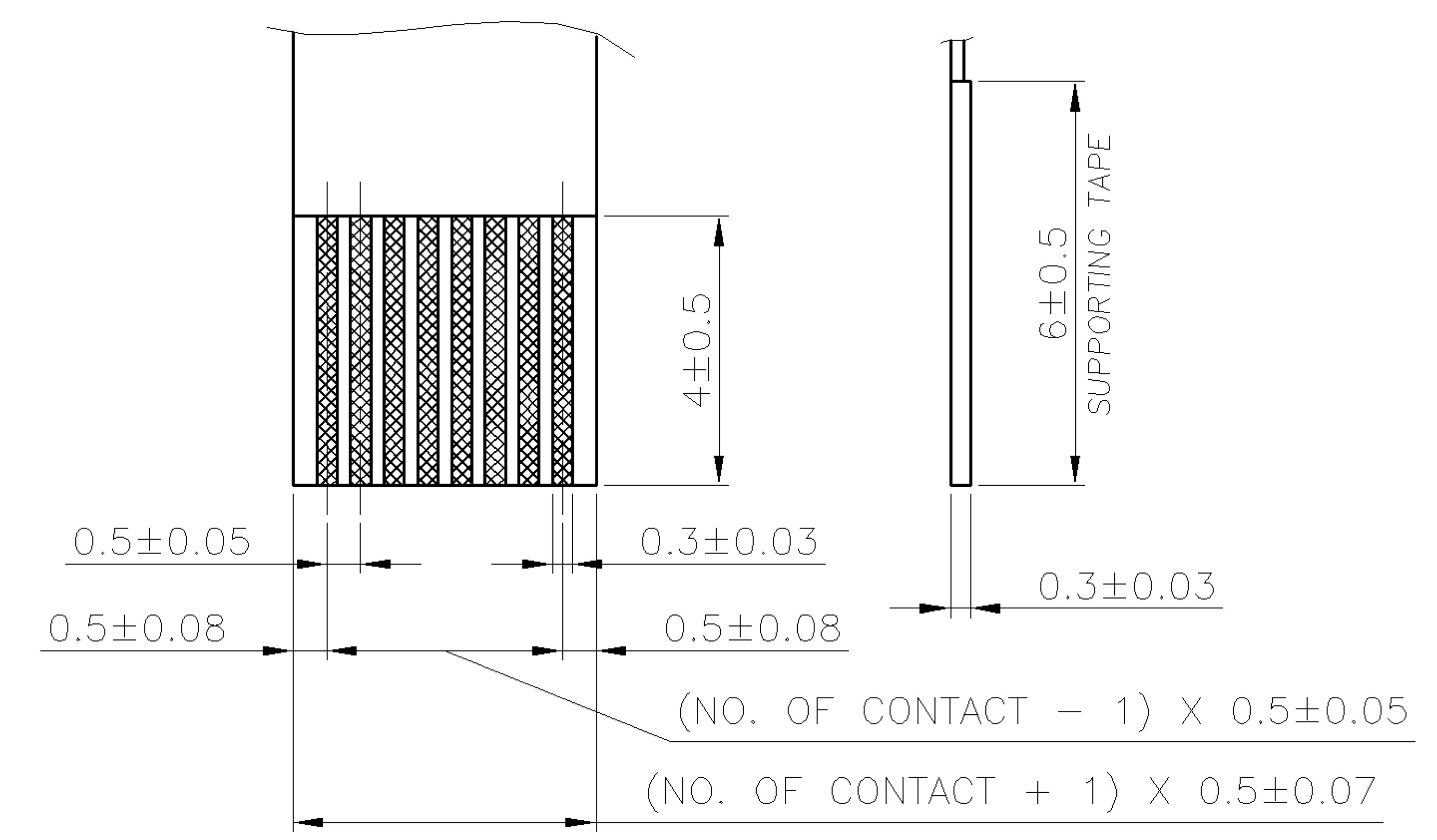

RECOMMENDED FFC LAYOUT

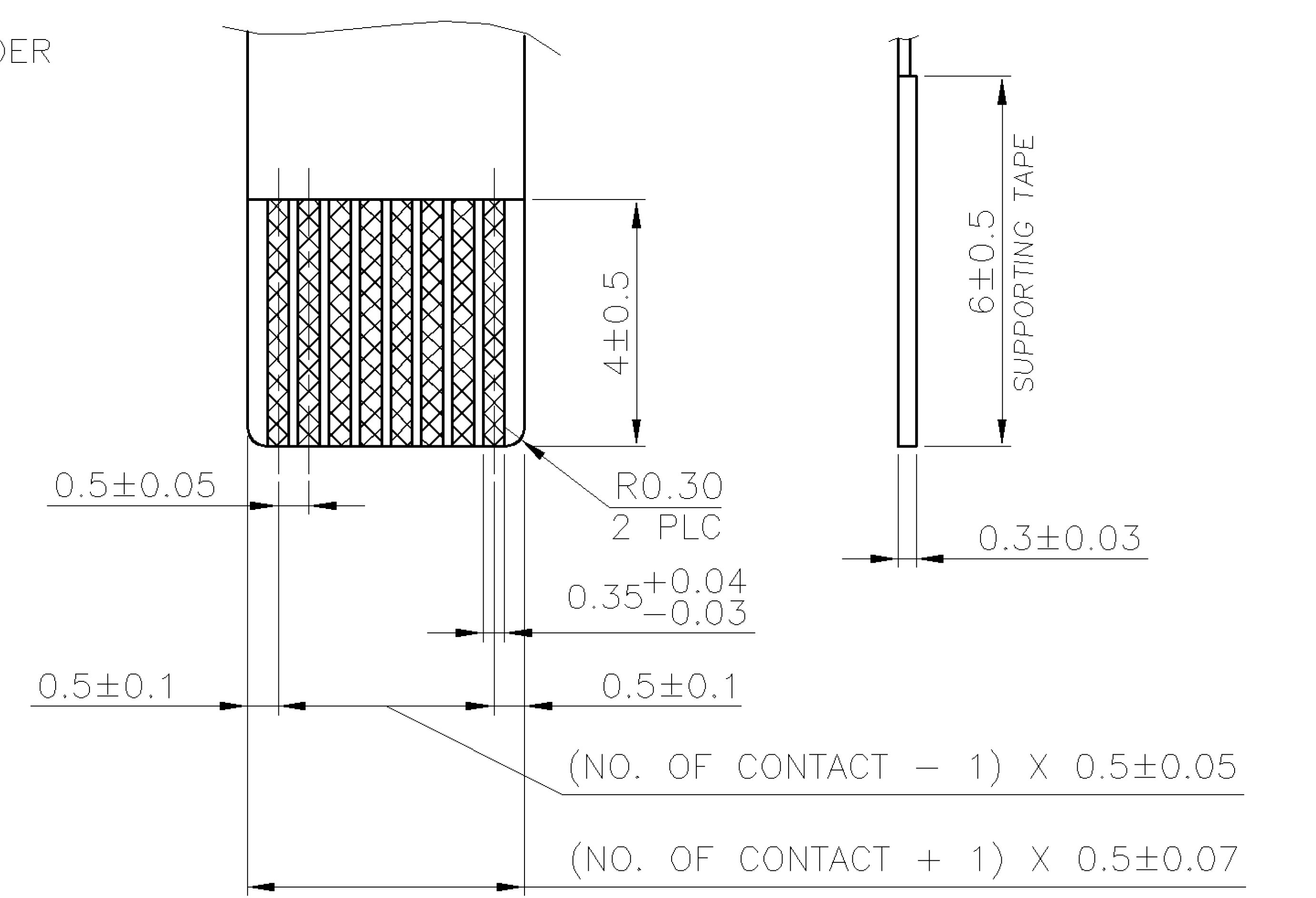

RECOMMENDED FPC LAYOUT

WEIGHT	D	C	B	A	NO. OF CONTACTS	PART NUMBER
0.34g	17.70	16.90	12.65	11.50	24	6-1734742-0
0.52g	25.70	24.90	20.65	19.50	40	4-1734742-0
0.51g	25.20	24.40	20.15	19.00	39	3-1734742-9
0.50g	24.70	23.90	19.65	18.50	38	3-1734742-8
0.49g	24.20	23.40	19.15	18.00	37	3-1734742-7
0.48g	23.70	22.90	18.65	17.50	36	3-1734742-6
0.46g	23.20	22.40	18.15	17.00	35	3-1734742-5
0.45g	22.70	21.90	17.65	16.50	34	3-1734742-4
0.44g	22.20	21.40	17.15	16.00	33	3-1734742-3
0.43g	21.70	20.90	16.65	15.50	32	3-1734742-2
0.42g	21.20	20.40	16.15	15.00	31	3-1734742-1
0.41g	20.70	19.90	15.65	14.50	30	3-1734742-0
0.40g	20.20	19.40	15.15	14.00	29	2-1734742-9
0.39g	19.70	18.90	14.65	13.50	28	2-1734742-8
0.38g	19.20	18.40	14.15	13.00	27	2-1734742-7
0.37g	18.70	17.90	13.65	12.50	26	2-1734742-6
0.36g	18.20	17.40	13.15	12.00	25	2-1734742-5
0.34g	17.70	16.90	12.65	11.50	24	2-1734742-4
0.33g	17.20	16.40	12.15	11.00	23	2-1734742-3
0.32g	16.70	15.90	11.65	10.50	22	2-1734742-2
0.31g	16.20	15.40	11.15	10.00	21	2-1734742-1
0.30g	15.70	14.90	10.65	9.50	20	2-1734742-0
0.29g	15.20	14.40	10.15	9.00	19	1-1734742-9
0.28g	14.70	13.90	9.65	8.50	18	1-1734742-8
0.27g	14.20	13.40	9.15	8.00	17	1-1734742-7
0.26g	13.70	12.90	8.65	7.50	16	1-1734742-6
0.25g	13.20	12.40	8.15	7.00	15	1-1734742-5
0.24g	12.70	11.90	7.65	6.50	14	1-1734742-4
0.22g	12.20	11.40	7.15	6.00	13	1-1734742-3
0.21g	11.70	10.90	6.65	5.50	12	1-1734742-2
0.20g	11.20	10.40	6.15	5.00	11	1-1734742-1
0.19g	10.70	9.90	5.65	4.50	10	1-1734742-0
0.18g	10.20	9.40	5.15	4.00	9	1734742-9
0.17g	9.70	8.90	4.65	3.50	8	1734742-8
0.16g	9.20	8.40	4.15	3.00	7	1734742-7
0.15g	8.70	7.90	3.65	2.50	6	1734742-6

NOTE:

- MATERIAL:  
HOUSING: THERMOPLASTIC WITH 33% GF, UL 94V-0, BLACK COLOR.  
ACTUATOR: THERMOPLASTIC, UL 94V-0, BROWN COLOR.  
CONTACTS: PHOSPHOR BRONZE.  
TABS: BRASS.
- FINISH:  
CONTACTS: GOLD FLASH OVER 50µ" MIN. NICKEL ON ENTIRE CONTACT.  
CONTACTS: 30µ" MIN. GOLD ON CONTACT AREA, WITH GOLD FLASH OVER 50µ" MIN. NICKEL ON ENTIRE CONTACT.  
TABS: 120µ" MIN. MATTE-TIN OVER 50µ" MIN. NICKEL.
- REFLOW SOLDER CAPABLE TO 260°C AS PER TE CONNECTIVITY SPEC. 109-201, CONDITION B.
- NO TYCO LOGO AND DATE CODE ON THE PRODUCT.

TOLERANCES UNLESS OTHERWISE SPECIFIED: 0 PLC ±- 1 PLC ±0.2 2 PLC ±0.1 3 PLC ±0.05 ANGLES ±3'	DWN A. WU 01-DEC-2005		NAME		
	CHK S. HOU 01-DEC-2005		FPC/FFC CONN., 0.5 MM PITCH, ZIF, VERTICAL, SMT, TYPE A		
MATERIAL SEE NOTE	APVD W.J. KE 01-DEC-2005	PRODUCT SPEC 108-57324			
FINISH SEE NOTE	QUALIFICATION TEST REPORT 501-57364	LOC DW	SIZE A <sub>3</sub>	DRAWING NO C-1734742	REV P
	WEIGHT -	SCALE --		SHEET 1 OF 2	

P	REVISION RECORD	ECO	REVISOR	DATE
LTR	ECO	ECO	02APR11	

PRINT DIST DW

NUMBER  
C-1734742

3RD ANGLE PROJECTION

METRIC

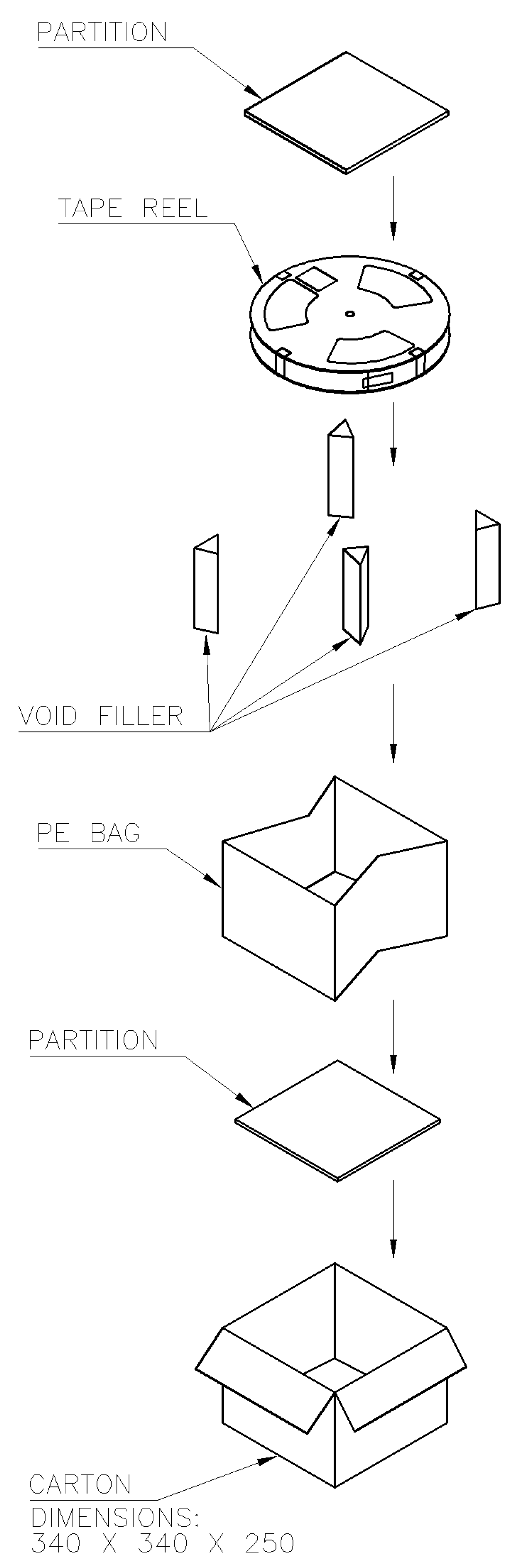
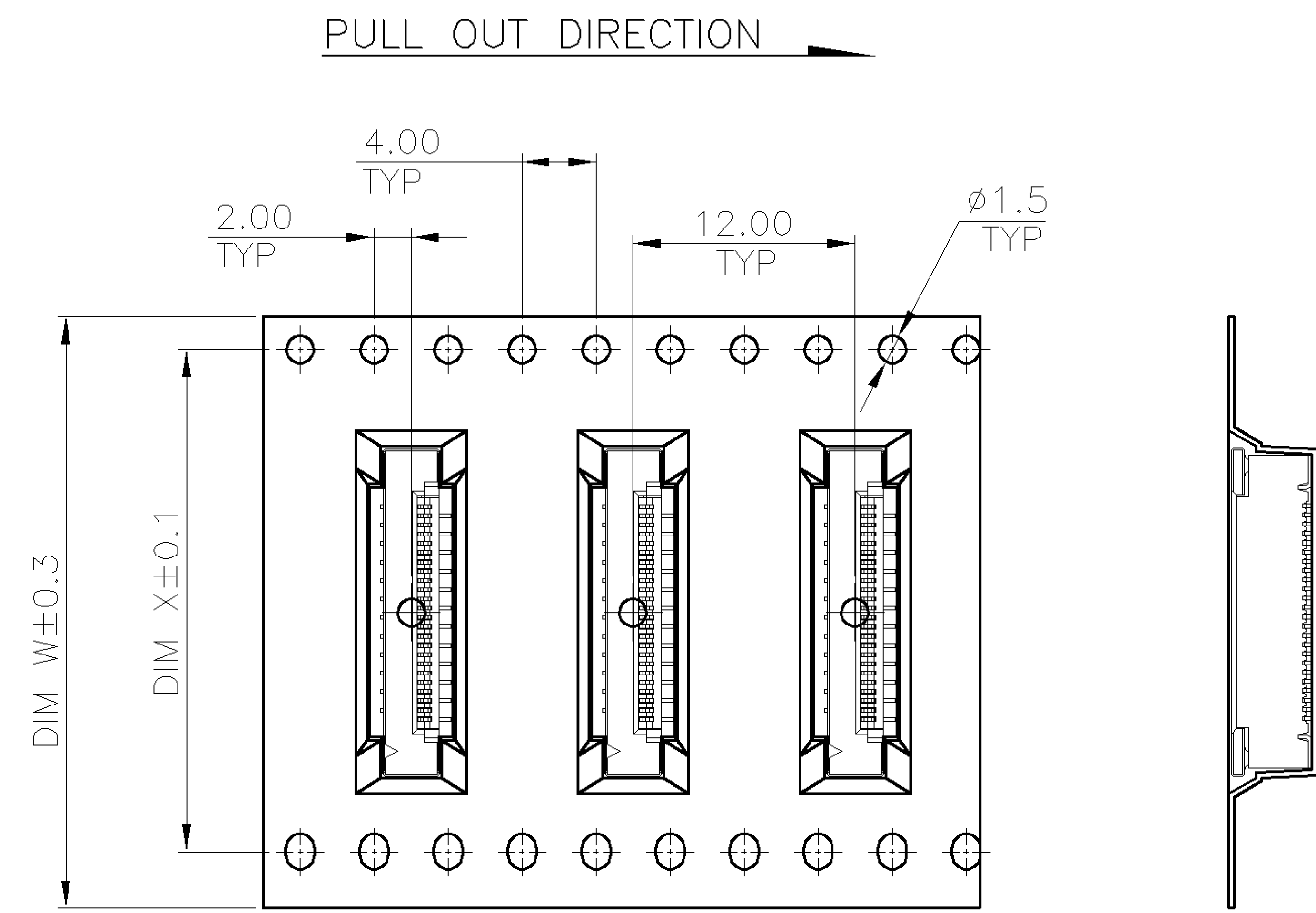
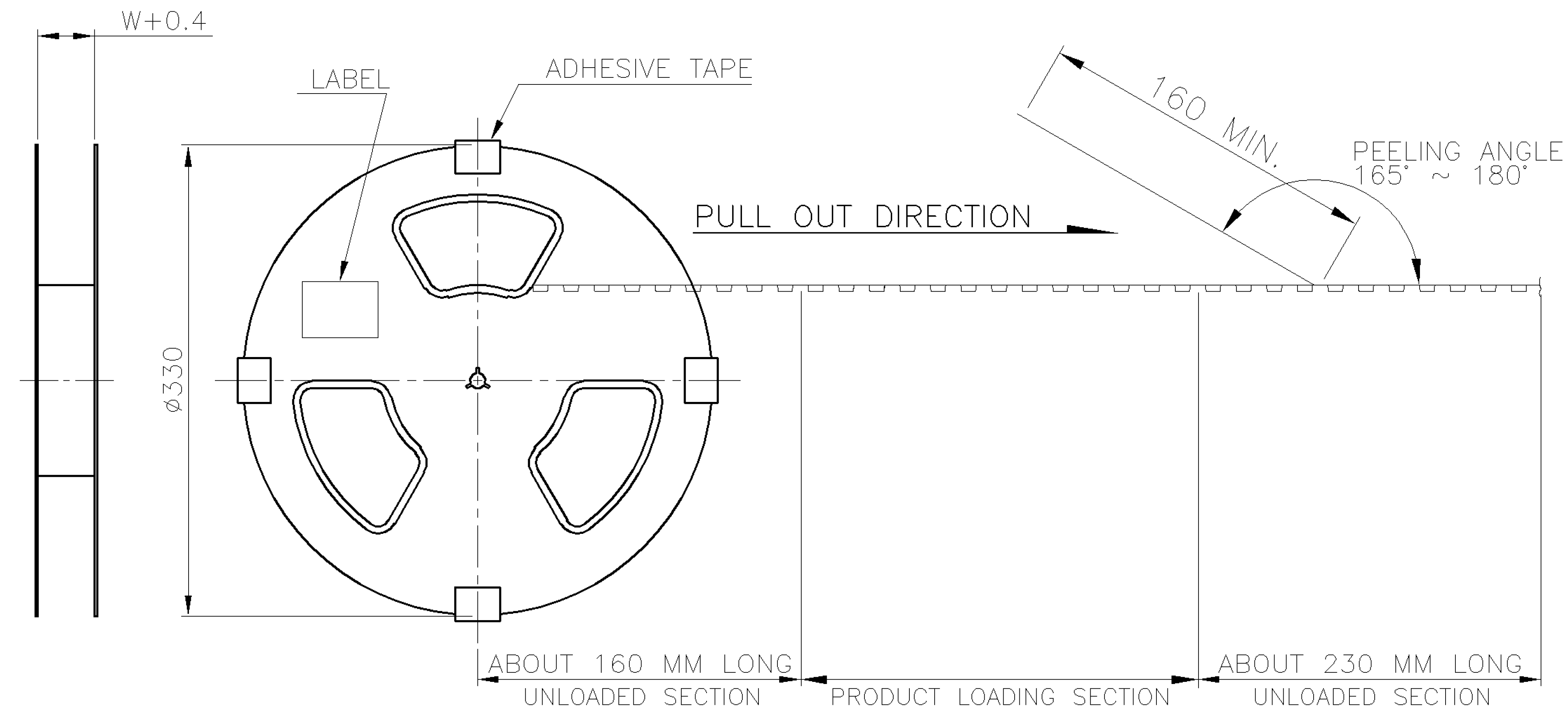

PCS/REEL	REELS/CARTON	QUANTITY	DIM W	DIM X	G/W (KG)	N/W (KG)	NO. OF CONTACTS
					4.61	2.08	40
					4.57	2.04	39
					4.53	2.00	38
					4.49	1.96	37
					4.45	1.92	36
					4.37	1.84	35
					4.33	1.80	34
					4.29	1.76	33
					4.25	1.72	32
					4.21	1.68	31
					6.05	2.46	30
					5.99	2.40	29
					5.93	2.34	28
					5.87	2.28	27
					5.81	2.22	26
					5.75	2.16	25
					5.63	2.04	24
					5.57	1.98	23
					5.51	1.92	22
					5.45	1.86	21
					5.58	2.10	20
					5.51	2.03	19
					5.44	1.96	18
					5.37	1.89	17
					5.30	1.82	16
					5.23	1.75	15
					5.16	1.68	14
					5.02	1.54	13
					4.95	1.47	12
					4.88	1.40	11
					4.81	1.33	10
					4.74	1.26	9
					4.67	1.19	8
					4.60	1.12	7
					4.53	1.05	6

TOLERANCES UNLESS OTHERWISE SPECIFIED: 0 PLC ±- 1 PLC ±- 2 PLC ±- 3 PLC ±- ANGLES ±-		DWN A. WU 01-DEC-2005	TE Connectivity NAME FPC/FFC CONN., 0.5 MM PITCH, ZIF, VERTICAL, SMT, TYPE A			
MATERIAL -		CHK S. HOU 01-DEC-2005				
FINISH -		APVD W.J. KE 01-DEC-2005	LOC DW	SIZE A <sub>3</sub>	DRAWING NO C-1734742	REV P
WEIGHT		APPLICATION SPEC	SCALE		SHEET 2 OF 2	

LTR	REVISION RECORD	SEE SHEET 1.	ECO	DWN CHK	DATE
-----	-----------------	--------------	-----	------------	------

CUSTOMER DRAWING

DIMENSIONS IN MILLIMETERS. DO NOT SCALE PRINT.

PRINT  
DIST  
DW

8 7 6 5 4 3 2 1

单击下面可查看定价，库存，交付和生命周期等信息

[>>TE Connectivity\(泰科\)](#)