

## 12V/24V High Sensitivity Hall IC for FAN Driver

### Features

- **On-Chip Hall Sensor**
- **12V/24V Operating Supply Voltage Available**
- **High Sensitivity Hall Effect Sensor IC:  $\pm 60G$**
- **Built-in Output Protection Clamping Circuit**
- **Lock Protection and Auto Restart Function**
- **4 Pin TO-92M4 Package**
- **Lead Free and Green Devices Available (RoHS Compliant)**

### General Description

The APX9189 is an integrated Hall Effect Sensor IC designed for electric commutation of two-phase DC brushless motor applications. The device is built-in lock protection. When fan is locked, the device will enter the lock protection mode. The APX9189 is available in a low cost TO-92M4 package.

### Applications

- **Brushless DC Fans**
- **Brushless DC Motors**

### Pin Configuration

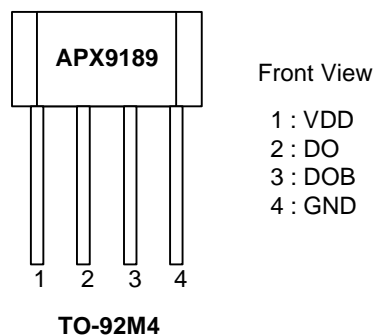

### Ordering and Marking Information

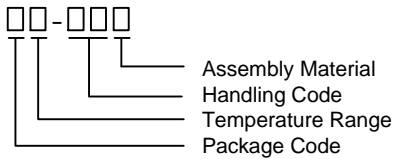
APX9189		Package Code E : TO92-M4 Operating Ambient Temperature Range I : -40 to 85 °C Handling Code PB : Plastic Bag Assembly Material G : Halogen and Lead Free Device
APX9189 E :	<div style="border: 1px solid black; padding: 5px; display: inline-block;">                     APX                      9189                      XXXXX                 </div>	XXXXX - Date Code

Note: ANPEC lead-free products contain molding compounds/die attach materials and 100% matte tin plate termination finish; which are fully compliant with RoHS. ANPEC lead-free products meet or exceed the lead-free requirements of IPC/JEDEC J-STD-020D for MSL classification at lead-free peak reflow temperature. ANPEC defines "Green" to mean lead-free (RoHS compliant) and halogen free (Br or Cl does not exceed 900ppm by weight in homogeneous material and total of Br and Cl does not exceed 1500ppm by weight).

ANPEC reserves the right to make changes to improve reliability or manufacturability without notice, and advise customers to obtain the latest version of relevant information to verify before placing orders.

## Absolute Maximum Ratings (Note 1)

Symbol	Parameter	Rating	Unit
V <sub>DD</sub>	VDD Pin Supply Voltage	-0.3 to 35	V
V <sub>DO, DOB</sub>	Output Pin (DO, DOB) Output Voltage	-0.3 to V <sub>OUT-CLAMP</sub>	V
I <sub>OUT</sub>	Maximum Output Pin (DO, DOB) Sink Current – Continuous Peak (Start-Up)	250 500	mA
T <sub>J</sub>	Maximum Junction Temperature	150	°C
T <sub>STG</sub>	Storage Temperature	-65 to 150	°C
T <sub>SOR</sub>	Maximum Lead Soldering Temperature, 10 Seconds	260	°C

Note1: Stresses beyond those listed under "absolute maximum ratings" may cause permanent damage to the device. These are stress ratings only and functional operation of the device at these or any other conditions beyond those indicated under "recommended operating conditions" is not implied. Exposure to absolute maximum rating conditions for extended periods may affect device reliability.

## Thermal Characteristics

Symbol	Parameter	Typical Value	Unit
θ <sub>JA</sub>	Thermal Resistance-Junction to Ambient <sup>(Note 2)</sup> TO-92M4	200	°C/W
P <sub>D</sub>	Power Dissipation, T <sub>A</sub> =25°C	500	mW

Note 2 : The maximum allowable power dissipation at any T<sub>A</sub> (ambient temperature) is calculated using: P<sub>D</sub> (max) = (T<sub>J</sub> – T<sub>A</sub>) / θ<sub>JA</sub>; T<sub>J</sub> = 125°C. Exceeding the maximum allowable power dissipation will result in excessive die temperature.

## Recommended Operation Conditions

Symbol	Parameter	Range	Unit
V <sub>DD</sub>	VDD Supply Voltage	3.5 to 30	V
T <sub>A</sub>	Operating Ambient Temperature	-40 to 85	°C
T <sub>J</sub>	Junction Temperature	-40 to 125	°C

## Electrical Characteristics (T<sub>A</sub>=25°C, V<sub>DD</sub>=24V unless otherwise noted)

Symbol	Parameter	Test Conditions	APX9189			Unit
			Min.	Typ.	Max.	
I <sub>DD1</sub>	VDD Supply Current	V <sub>DD</sub> =3.5V, Output Open	-	2	4	mA
I <sub>DD2</sub>		V <sub>DD</sub> =24V, Output Open	-	2	4	mA
V <sub>SAT</sub>	Output Saturation Voltage	V <sub>DD</sub> =24V, I <sub>OUT</sub> =150mA	-	300	450	mV
		V <sub>DD</sub> =24V, I <sub>OUT</sub> =250mA	-	500	700	mV
V <sub>OUT-CLAMP</sub>	DO, DOB Output Clamp Voltage	DO, DOB Pin Off	55	-	-	V
I <sub>DOH</sub>	DO Pin High Input Current	V <sub>DO</sub> =48V, B<B <sub>rp</sub>	-	160	200	µA
I <sub>DOBH</sub>	DOB Pin High Input Current	V <sub>DOB</sub> =48V, B>B <sub>op</sub>	-	160	200	µA
T <sub>ON</sub>	Lock Detection On Time		-	0.25	-	sec
T <sub>OFF</sub>	Lock Detection Off Time		-	1.5	-	sec

**Magnetic Characteristics** ( $T_A=25^{\circ}\text{C}$ ,  $V_{DD}=24\text{V}$  unless otherwise noted)

Symbol	Parameter	Test Conditions	APX9189			Unit
			Min.	Typ.	Max.	
$B_{OP}$	Magnetic Operation Point		10	30	60	Gauss
$B_{RP}$	Magnetic Release Point		-60	-30	-10	Gauss
$B_{hys}$	Magnetic Hysteresis		20	60	-	Gauss

### Typical Operating Characteristics

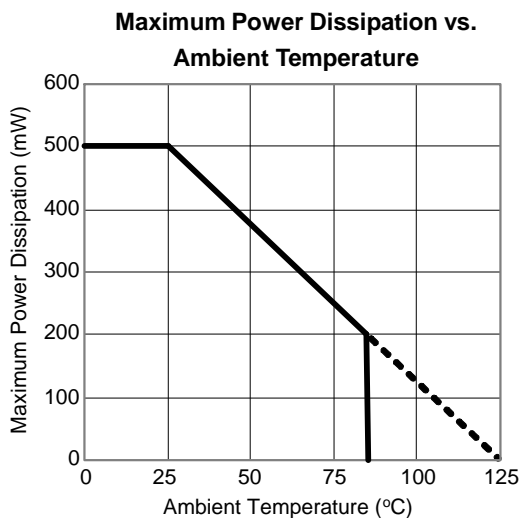
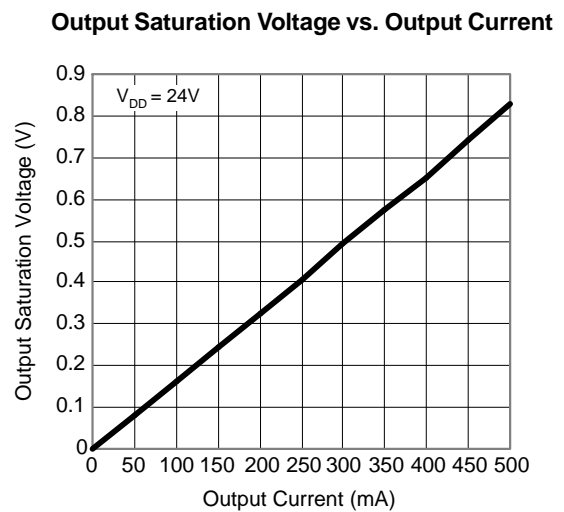
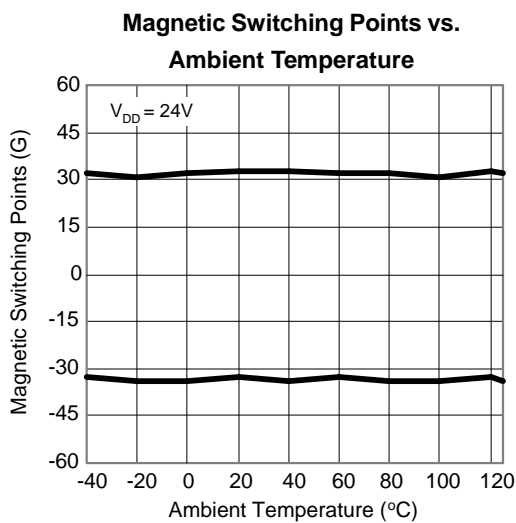
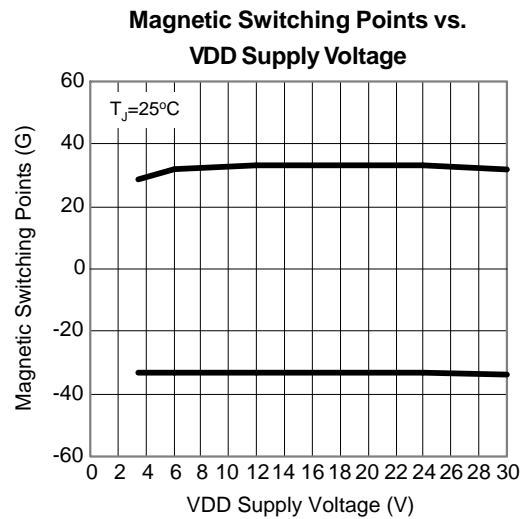
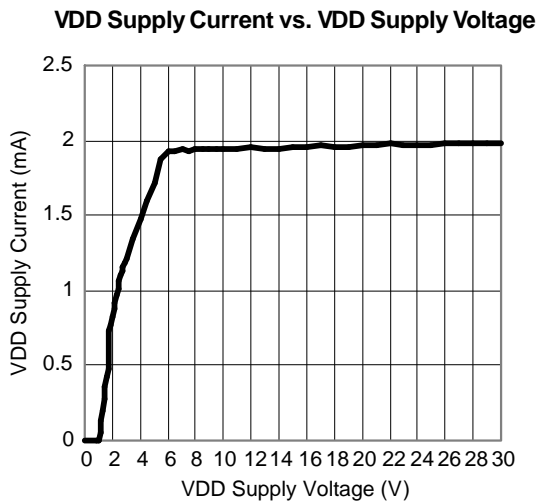

### Pin Description

PIN		FUNCTION
NO.	NAME	
1	VDD	Supply Voltage Input.
2	DO	Open Drain Output. Controlled by magnetic field input.
3	DOB	Open Drain Output. Controlled by magnetic field input.
4	GND	Ground of the IC.

### Block Diagram

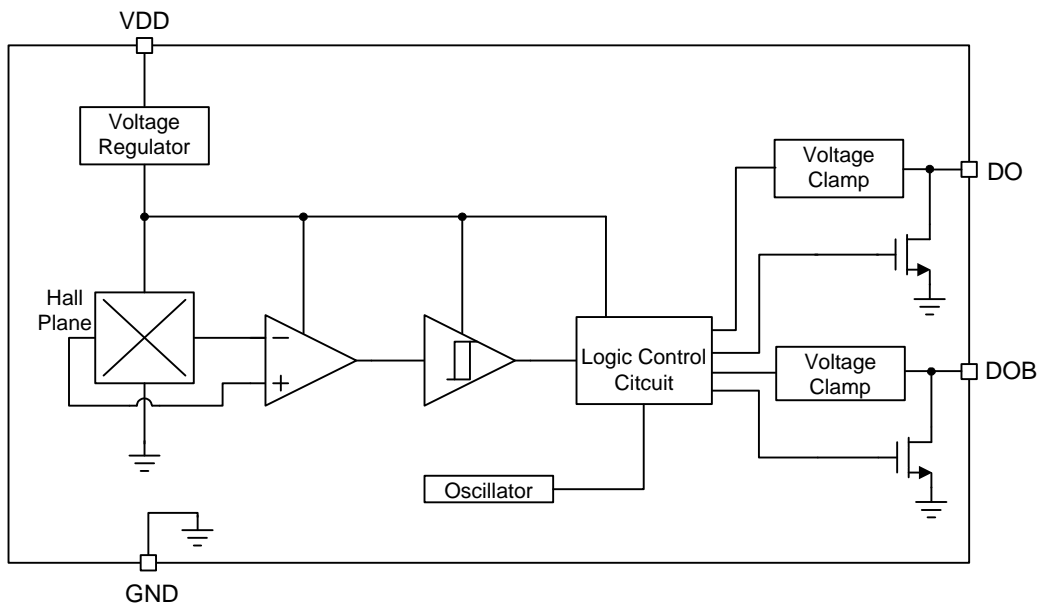

## Typical Application Circuit

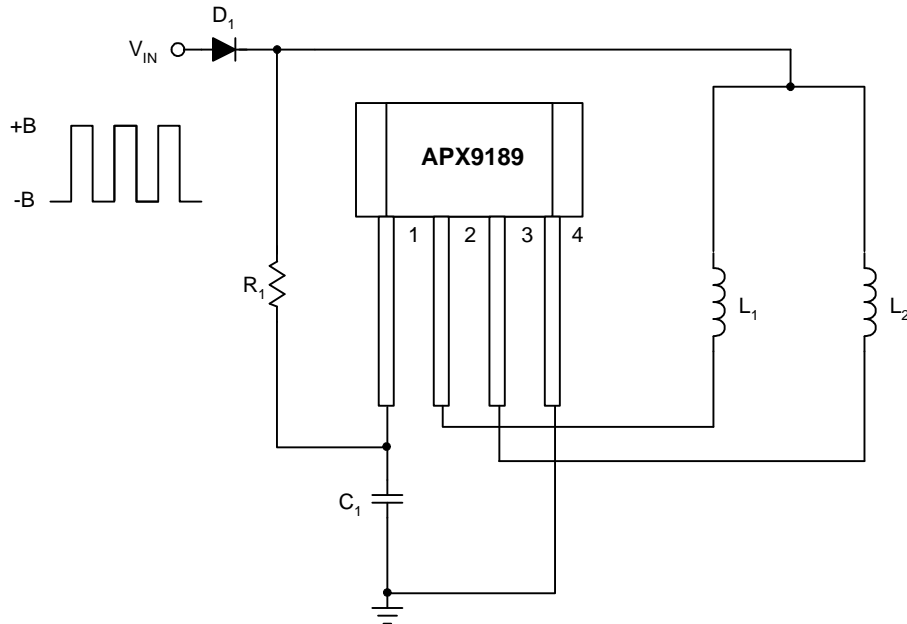

Notes:  $D_1$  is to protect circuit and coils when reverse power input.  
 $C_1$ : typical  $1\mu\text{F}/50\text{V}$  capacitor recommended.  
 $R_1$ : typical  $5.1\Omega$  resistor recommended.  
 The  $R_1$  and  $C_1$  are to avoid inrush current to damage IC at hot plug ON/OFF moments and the  $R_1$  and  $C_1$  values need to be selected base on coils design.

## Function Description

### Output Switch Principle

The APX9189 is built in a hall-effect sensor plane to sense the vertical magnetic flux density (B). There are two output drivers in APX9189 to drive two-phase DC brushless motor. When the South pole magnetic field close to the IC marking surface and the magnetic flux density higher than operate point (Bop), the DO pin output will turn ON and the DOB pin output will turn OFF. When the South pole magnetic field far away the IC marking surface and North pole magnetic field close to the IC marking surface until the magnetic flux density higher than release point (Brp), the DO pin output will turn OFF and the DOB pin output will turn ON.

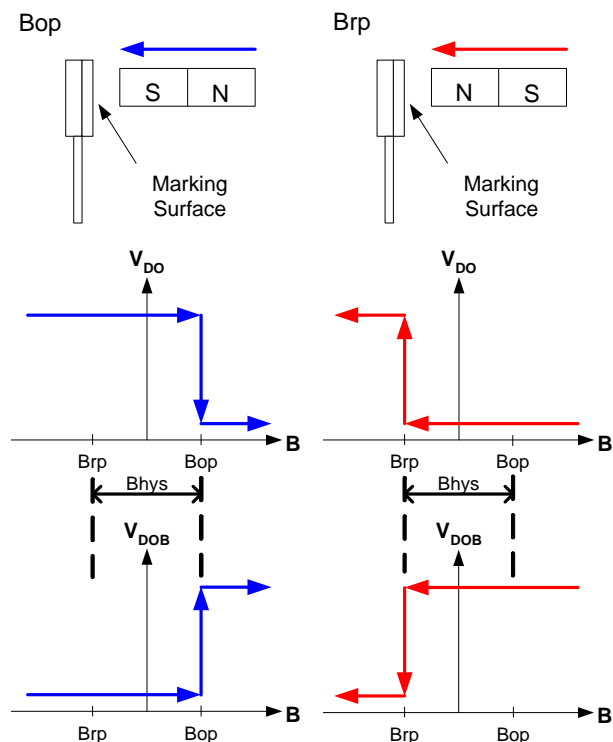
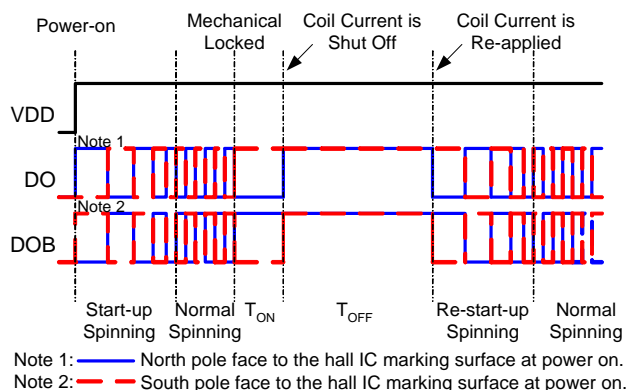

### Lockup Protection and Automatic Restart

The APX9189 detects the rotation of the motor by internal hall sensor signal, and adjusts lock detection ON time ( $T_{ON}$ ) and lock detection OFF time ( $T_{OFF}$ ) by internal counter.

Package Information

TO-92M4

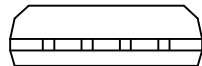
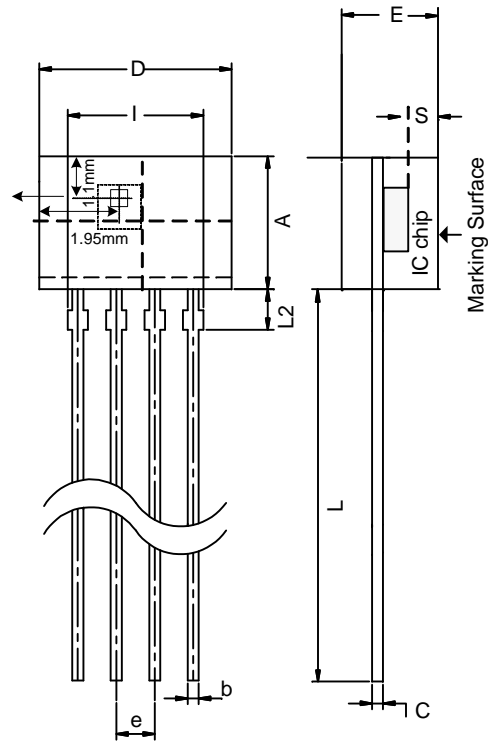

Position of Hall Sensor  
reference to the top-left of package  
X= 1.95±0.1mm  
Y= 1.1±0.1mm

SYMBOL	TO-92M4			
	MILLIMETERS		INCHES	
	MIN.	MAX.	MIN.	MAX.
A	3.60	3.70	0.142	0.146
b	0.35	0.41	0.014	0.016
c	0.35	0.41	0.014	0.016
D	5.17	5.27	0.204	0.208
e	1.27 BSC		0.050 BSC	
E	1.50	1.60	0.059	0.063
I	4.04	4.34	0.159	0.171
L	13.80	14.80	0.543	0.583
L2	1.34	1.54	0.053	0.061
s	0.70	0.76	0.028	0.030



### Classification Profile

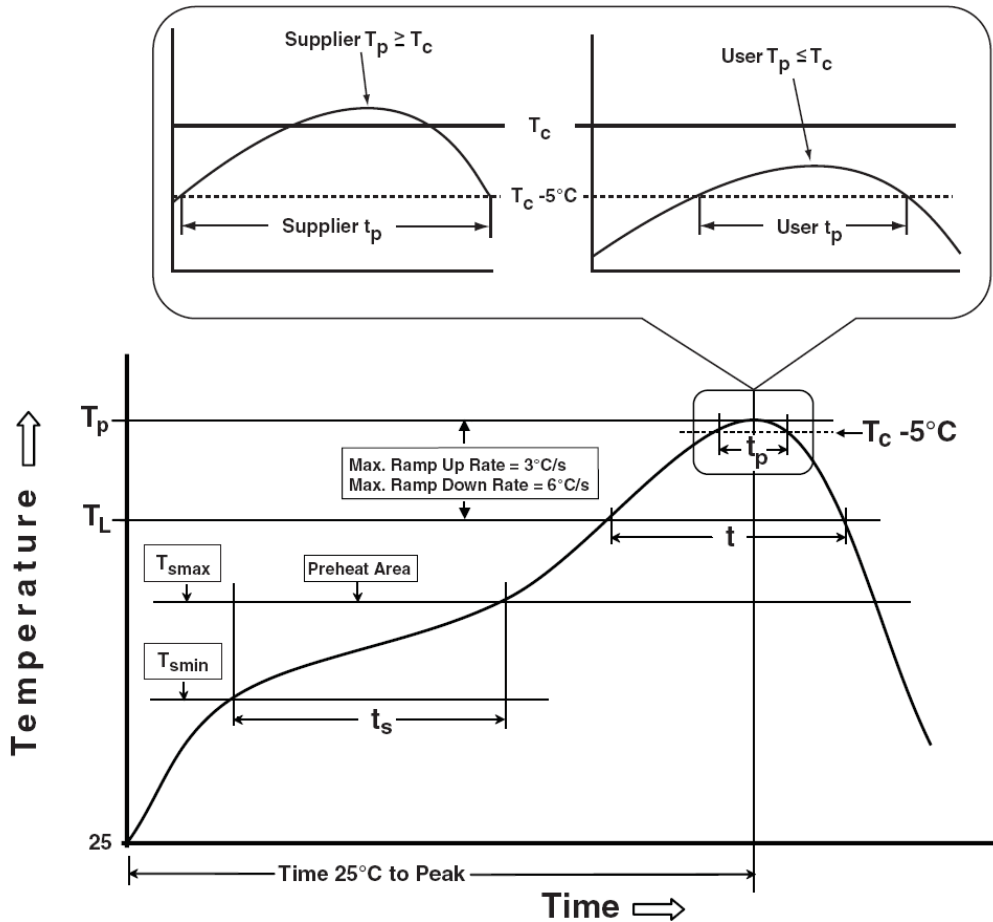

### Classification Reflow Profiles

Profile Feature	Sn-Pb Eutectic Assembly	Pb-Free Assembly
<b>Preheat &amp; Soak</b>		
Temperature min ( $T_{smin}$ )	100 °C	150 °C
Temperature max ( $T_{smax}$ )	150 °C	200 °C
Time ( $T_{smin}$ to $T_{smax}$ ) ( $t_s$ )	60-120 seconds	60-120 seconds
Average ramp-up rate ( $T_{smax}$ to $T_p$ )	3 °C/second max.	3 °C/second max.
Liquidous temperature ( $T_L$ )	183 °C	217 °C
Time at liquidous ( $t_L$ )	60-150 seconds	60-150 seconds
Peak package body Temperature ( $T_p$ )*	See Classification Temp in table 1	See Classification Temp in table 2
Time ( $t_p$ )** within 5°C of the specified classification temperature ( $T_c$ )	20** seconds	30** seconds
Average ramp-down rate ( $T_p$ to $T_{smax}$ )	6 °C/second max.	6 °C/second max.
Time 25°C to peak temperature	6 minutes max.	8 minutes max.
* Tolerance for peak profile Temperature ( $T_p$ ) is defined as a supplier minimum and a user maximum.		
** Tolerance for time at peak profile temperature ( $t_p$ ) is defined as a supplier minimum and a user maximum.		

## Classification Reflow Profiles (Cont.)

Table 1. SnPb Eutectic Process – Classification Temperatures (Tc)

Package Thickness	Volume mm <sup>3</sup> <350	Volume mm <sup>3</sup> ≥350
<2.5 mm	235 °C	220 °C
≥2.5 mm	220 °C	220 °C

Table 2. Pb-free Process – Classification Temperatures (Tc)

Package Thickness	Volume mm <sup>3</sup> <350	Volume mm <sup>3</sup> 350-2000	Volume mm <sup>3</sup> >2000
<1.6 mm	260 °C	260 °C	260 °C
1.6 mm – 2.5 mm	260 °C	250 °C	245 °C
≥2.5 mm	250 °C	245 °C	245 °C

## Reliability Test Program

Test item	Method	Description
SOLDERABILITY	JESD-22, B102	5 Sec, 245°C
HOLT	JESD-22, A108	1000 Hrs, Bias @ T <sub>J</sub> =125°C
PCT	JESD-22, A102	168 Hrs, 100%RH, 2atm, 121°C
TCT	JESD-22, A104	500 Cycles, -65°C~150°C
HBM	MIL-STD-883-3015.7	VHBM 2KV
MM	JESD-22, A115	VMM 200V
Latch-Up	JESD 78	10ms, 1 <sub>tr</sub> 100mA

## Customer Service

### Anpec Electronics Corp.

Head Office :

No.6, Dusing 1st Road, SBIP,  
Hsin-Chu, Taiwan  
Tel : 886-3-5642000  
Fax : 886-3-5642050

Taipei Branch :

2F, No. 11, Lane 218, Sec 2 Jhongsing Rd.,  
Sindian City, Taipei County 23146, Taiwan  
Tel : 886-2-2910-3838  
Fax : 886-2-2917-3838

单击下面可查看定价，库存，交付和生命周期等信息

[>>ANPEC\(台湾茂达\)](#)