

**36V Low Current Consumption
250mA CMOS Voltage Regulator**

LR6375 Series

■ INTRODUCTION

The LR6375 series are a group of positive voltage regulators manufactured by CMOS technologies with low power consumption and low dropout voltage, which provide large output currents even when the difference of the input-output voltage is small. The LR6375 series can deliver 250mA output current and allow an input voltage as high as 36V. The series are very suitable for the battery-powered equipments, such as RF applications and other systems requiring a quiet voltage source.

■ APPLICATIONS

- Cordless Phones
- Radio control systems
- Laptop, Palmtops and PDAs
- Single-lens reflex DSC
- PC peripherals with memory

■ BLOCK DIAGRAM

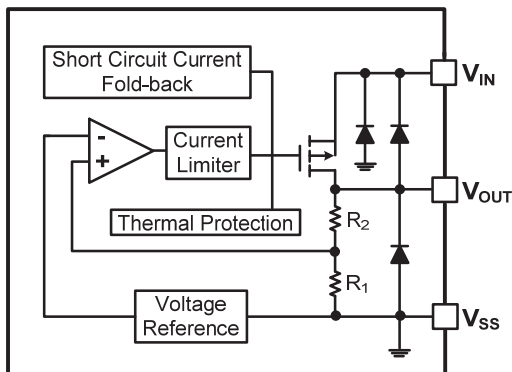

■ FEATURES

- Low Quiescent Current: 2μA
 - Operating Voltage Range: 2.5V~36V
 - Output Current: 250mA
 - Low Dropout Voltage:
400mV@100mA(V_{OUT}=3.3V)
 - Output Voltage: 2.1~ 12V
 - High Accuracy: ±2%/±1%(Typ.)
 - High Power Supply Rejection Ratio:
70dB@1kHz
 - Low Output Noise:
27xV_{OUT} μV_{RMS}(10Hz~100kHz)
 - Excellent Line and Load Transient Response
 - Built-in Current Limiter, Short-Circuit Protection
 - Over-Temperature Protection
 - Stable with Ceramic or Tantalum Capacitor
-
- Wireless Communication Equipments
 - Portable Audio Video Equipments
 - Car Navigation Systems
 - LAN Cards
 - Ultra Low Power Microcontrolle

■ ORDER INFORMATION

LR6375①②③④⑤

DESIGNATOR	SYMBOL	DESCRIPTION
①	A	Standard
②③④	Integer	Output Voltage e.g.12.0V=②:1, ③:2, ④:0
⑤	M/MC/MY	Package:SOT-23-3
	MF/MR	Package:SOT-23-5
	P/PT/PL	Package:SOT-89-3
	ES	Package:SOP8-PP

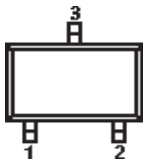
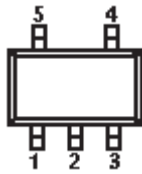
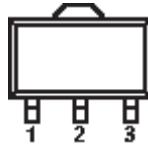
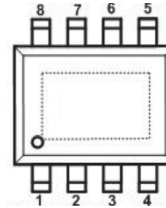
■ PIN CONFIGURATION
SOT-23-3

SOT-23-5

SOT-89-3

SOP8-PP

PIN NUMBER						PIN NAME	FUNCTION
SOT-23-3			SOT-89-3				
M	MC	MY	P	PT	PL		
1	3	3	1	2	2	V_{SS}	Ground
2	2	1	3	1	3	V_{OUT}	Output
3	1	2	2	3	1	V_{IN}	Power input

SOT-23-5

PIN NUMBER		PIN NAME	FUNCTION
MF	MR		
1	2	V_{IN}	Power Input
2	1	V_{SS}	Ground
3/4	4/5	NC	No Connection
5	3	V_{OUT}	Output

SOP8-PP

PIN NUMBER	PIN NAME	FUNCTION
ES		
1	V_{OUT}	Power Input
5	V_{SS}	Ground
8,9	V_{IN}	No Connection
2,3,4,6,7	NC	Output

■ ABSOLUTE MAXIMUM RATINGS⁽¹⁾

(Unless otherwise specified, T_A=25°C)

PARAMETER		SYMBOL	RATINGS	UNITS
Input Voltage ⁽²⁾		V _{IN}	-0.3~40	V
Output Voltage ⁽²⁾		V _{OUT}	-0.3~13	V
Power Dissipation	SOT-23	P _D	0.4	W
	SOT-89		0.6	W
	TO-92		0.6	W
	SOP8-PP		1.2	W
Operating Junction Temperature Range ⁽³⁾		T _j	150	°C
Storage Temperature		T _{stg}	-65~150	°C
Lead Temperature(Soldering, 10 sec)		T _{solder}	260	°C

(1) Stresses beyond those listed under *absolute maximum ratings* may cause permanent damage to the device. These are stress ratings only, and functional operation of the device at these or any other conditions beyond those indicated under *recommended operating conditions* is not implied. Exposure to absolute-maximum-rated conditions for extended periods may affect device reliability.

(2) All voltages are with respect to network ground terminal.

(3) This IC includes over temperature protection that is intended to protect the device during momentary overload. Junction temperature will exceed 125°C when over temperature protection is active. Continuous operation above the specified maximum operating junction temperature may impair device reliability.

■ RECOMMENDED OPERATING CONDITIONS

PARAMETER	MIN.	NOM.	MAX.	UNITS
Supply voltage at V _{IN}	2.5		36	V
Operating junction temperature range, T _j	-40		125	°C
Operating free air temperature range, T _A	-40		85	°C

■ ELECTRICAL CHARACTERISTICS

LR6375 Series (V_{IN}=V_{OUT}+2V, C_{IN}=C_{OUT}=1μF, T_A=25°C, unless otherwise specified)

PARAMETER	SYMBOL	CONDITIONS	MIN.	TYP. ⁽⁴⁾	MAX.	UNITS	
Input Voltage	V _{IN}		2.5	—	36	V	
Output Voltage Range	V _{OUT}		2.1	—	12	V	
DC Output Accuracy		I _{OUT} =10mA	-2	—	2	%	
			-1	—	1	%	
Dropout Voltage	V _{dif} ⁽⁵⁾	I _{OUT} = 100mA, V _{OUT} =3.3V	—	400	—	mV	
Supply Current	I _{SS}	I _{OUT} =0A, 2.1V ≤ V _{OUT} ≤ 5.0V	—	2	5	μA	
		I _{OUT} =0A, 5.0V < V _{OUT} ≤ 12.0V	-	5	10	μA	
Line Regulation	$\frac{\Delta V_{OUT}}{V_{OUT} \times \Delta V_{IN}}$	I _{OUT} = 10mA V _{OUT} + 1V ≤ V _{IN} ≤ 36V	—	0.01	0.3	%/V	
Load Regulation	ΔV_{OUT}	V _{IN} = V _{OUT} + 2V, 1mA ≤ I _{OUT} ≤ 100mA	—	10	—	mV	
Temperature Coefficient	$\frac{\Delta V_{OUT}}{V_{OUT} \times \Delta T_A}$	I _{OUT} =40mA, -40°C < T _A < 85°C		50		ppm/°C	
Output Current Limit	I _{LIM}	V _{OUT} = 0.5 × V _{OUT(Normal)}		350		mA	
Short Current	I _{SHORT}	V _{OUT} = V _{SS}	—	25	—	mA	
Power Supply Rejection Ratio	PSRR	I _{OUT} =50mA	100Hz		80		dB
			1kHz	—	70	—	
			10kHz	—	60	—	
			100kHz	—	50	—	
Output Noise Voltage	V _{ON}	BW=10Hz to 100kHz	—	27 × V _{OUT}	—	μV _{RMS}	
Thermal Shutdown Temperature	T _{SD}	I _{LOAD} = 30mA	—	160	—	°C	
Thermal Shutdown Hysteresis	ΔT _{SD}	—	—	20	—	°C	

(4) Typical numbers are at 25°C and represent the most likely norm.

(5) V_{dif}: The Difference Of Output Voltage And Input Voltage When Input Voltage Is Decreased Gradually Till Output Voltage Equals To 98% Of V_{OUT} (E).

■ TYPICAL APPLICATION CIRCUIT

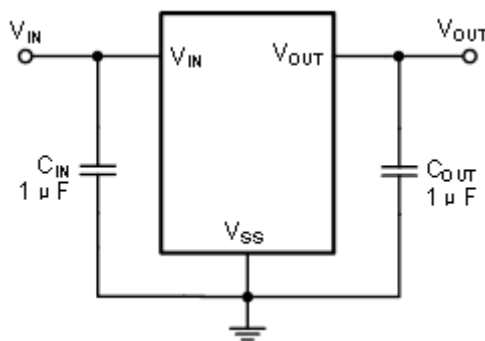

■ APPLICATION INFORMATION

Selection of Input/ Output Capacitors

In general, all the capacitors need to be low leakage. Any leakage the capacitors have will reduce efficiency, increase the quiescent current.

A recent trend in the design of portable devices has been to use ceramic capacitors to filter DC-DC converter inputs. Ceramic capacitors are often chosen because of their small size, low equivalent series resistance (ESR) and high RMS current capability. Also, recently, designers have been looking to ceramic capacitors due to shortages of tantalum capacitors.

Unfortunately, using ceramic capacitors for input filtering can cause problems. Applying a voltage step to a ceramic capacitor causes a large current surge that stores energy in the inductances of the power leads. A large voltage spike is created when the stored energy is transferred from these inductances into the ceramic capacitor. These voltage spikes can easily be twice the amplitude of the input voltage step. (See “Ceramic Input Capacitors Can Cause Overvoltage Transients”—Linear Technology application note 88, March 2001)

Many types of capacitors can be used for input bypassing, however, caution must be exercised when using multilayer ceramic capacitors (MLCC). Because of the self-resonant and high Q characteristics of some types of ceramic capacitors, high voltage transients can be generated under some start-up conditions, such as connecting the LDO input to a live power source. Adding a 3Ω resistor in series with an X5R ceramic capacitor will minimize start-up voltage transients.

The LDO also requires an output capacitor for loop stability. Connect a 1μF tantalum capacitor from OUT to GND close to the pins. For improved transient response, this output capacitor may be ceramic.

■ TYPICAL PERFORMANCE CHARACTERISTICS

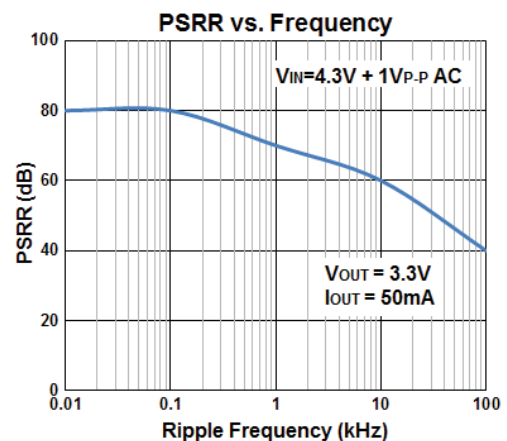
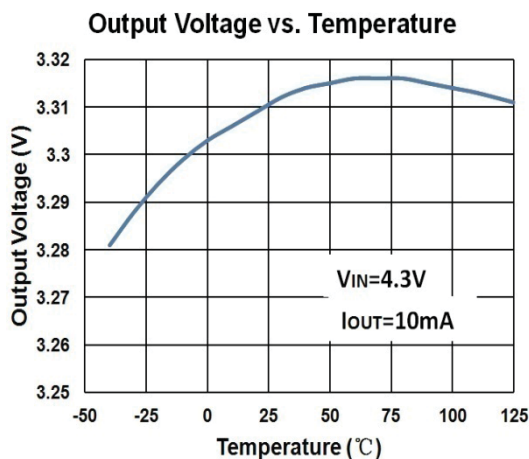

■ TYPICAL PERFORMANCE CHARACTERISTICS

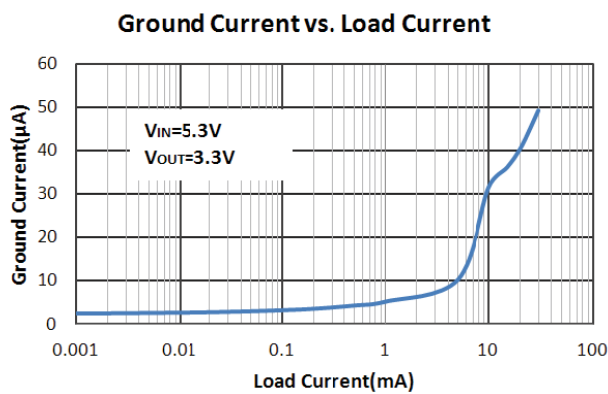
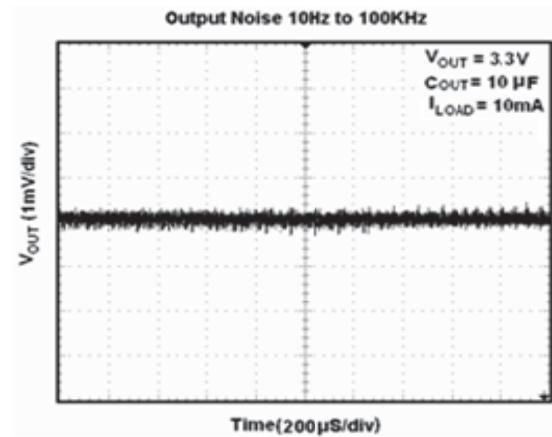
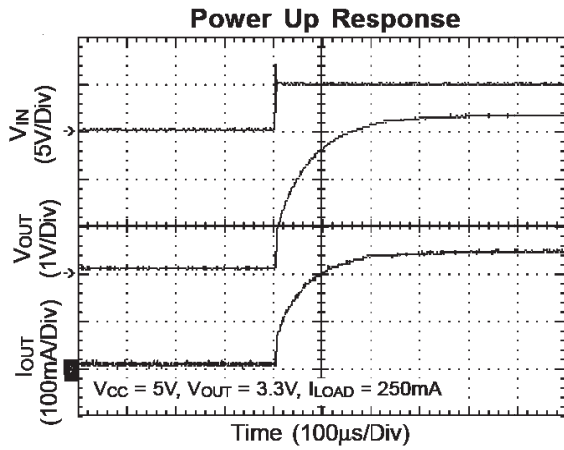
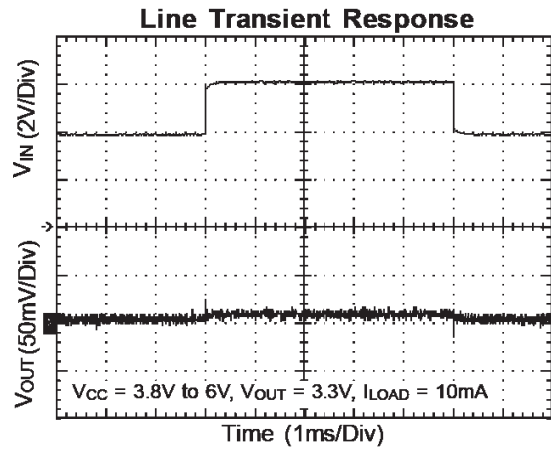
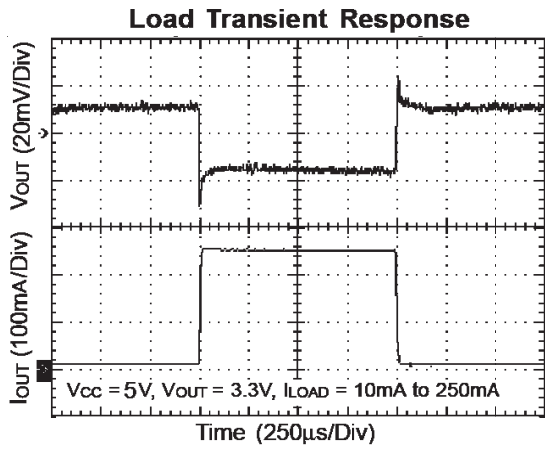

■ PACKAGING INFORMATION

● SOT-23-3 PACKAGE OUTLINE DIMENSIONS

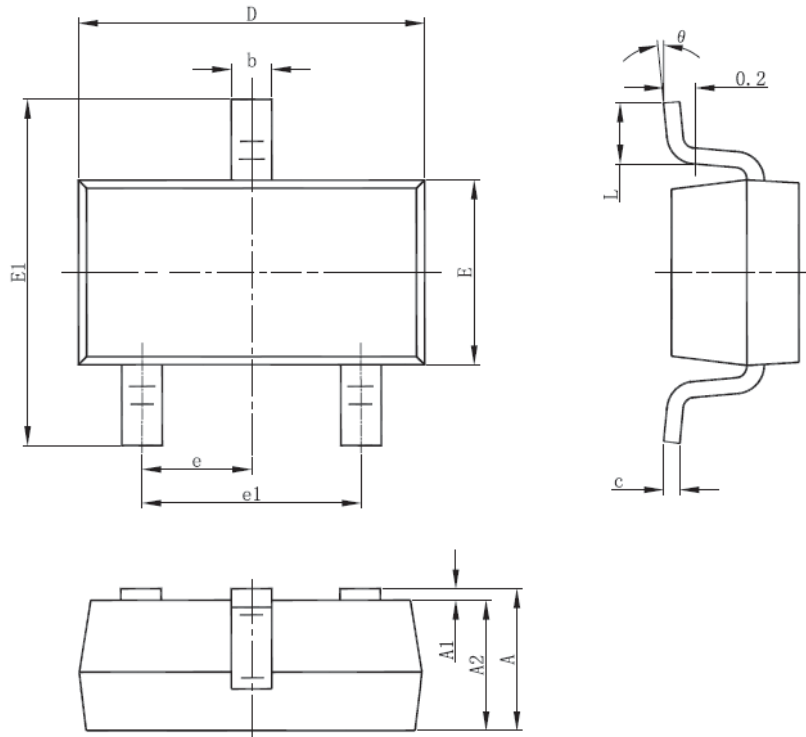

Symbol	Dimensions In Millimeters		Dimensions In Inches	
	Min.	Max.	Min.	Max.
A	1.050	1.250	0.041	0.049
A1	0.000	0.100	0.000	0.004
A2	1.050	1.150	0.041	0.045
b	0.300	0.500	0.012	0.020
c	0.100	0.200	0.004	0.008
D	2.820	3.020	0.111	0.119
E	1.500	1.700	0.059	0.067
E1	2.650	2.950	0.104	0.116
e	0.950(BSC)		0.037(BSC)	
e1	1.800	2.000	0.071	0.079
L	0.300	0.600	0.012	0.024
θ	0°	8°	0°	8°

● **SOT-23-5 PACKAGE OUTLINE DIMENSIONS**

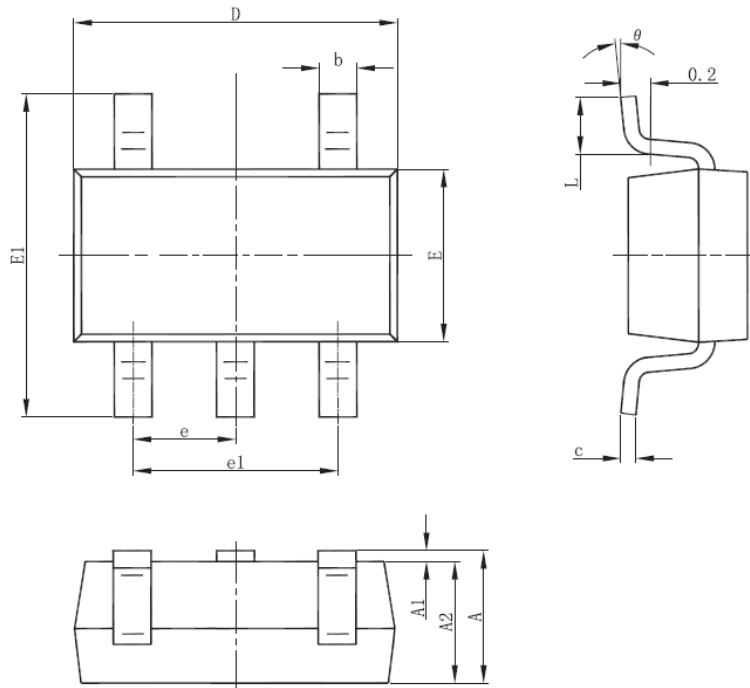

Symbol	Dimensions In Millimeters		Dimensions In Inches	
	Min.	Max.	Min.	Max.
A	1.050	1.250	0.041	0.049
A1	0.000	0.100	0.000	0.004
A2	1.050	1.150	0.041	0.045
b	0.300	0.500	0.012	0.020
c	0.100	0.200	0.004	0.008
D	2.820	3.020	0.111	0.119
E	1.500	1.700	0.059	0.067
E1	2.650	2.950	0.104	0.116
e	0.950(BSC)		0.037(BSC)	
e1	1.800	2.000	0.071	0.079
L	0.300	0.600	0.012	0.024
theta	0°	8°	0°	8°

● SOT-89-3 PACKAGE OUTLINE DIMENSIONS

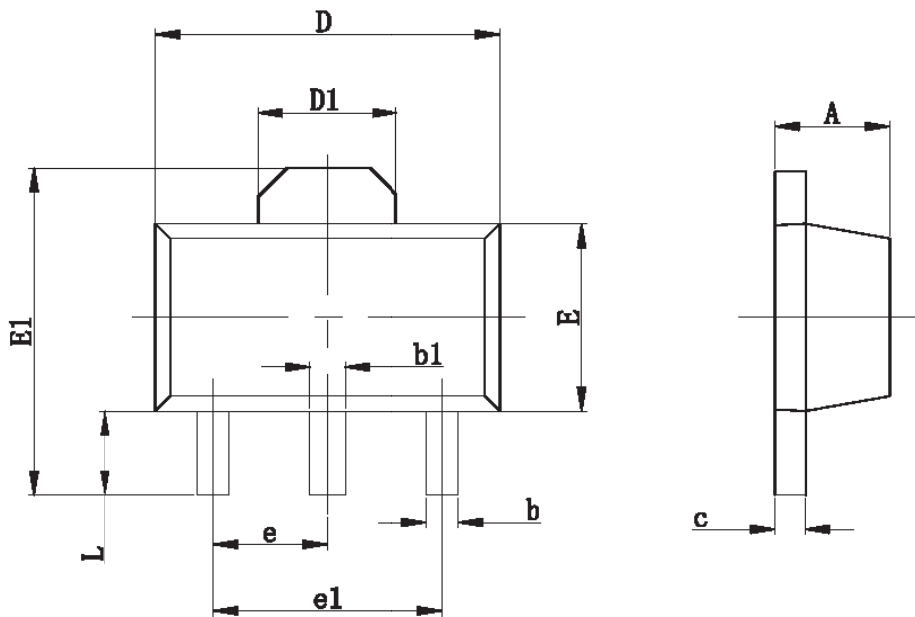

Symbol	Dimensions In Millimeters		Dimensions In Inches	
	Min.	Max.	Min.	Max.
A	1.400	1.600	0.055	0.063
b	0.320	0.520	0.013	0.197
b1	0.400	0.580	0.016	0.023
c	0.350	0.440	0.014	0.017
D	4.400	4.600	0.173	0.181
D1	1.550 REF		0.061 REF	
E	2.300	2.600	0.091	0.102
E1	3.940	4.250	0.155	0.167
e	1.500 TYP		0.060 TYP	
e1	3.000 TYP		0.118 TYP	
L	0.900	1.200	0.035	0.047

- SOP8-PP Package Outline Dimensions

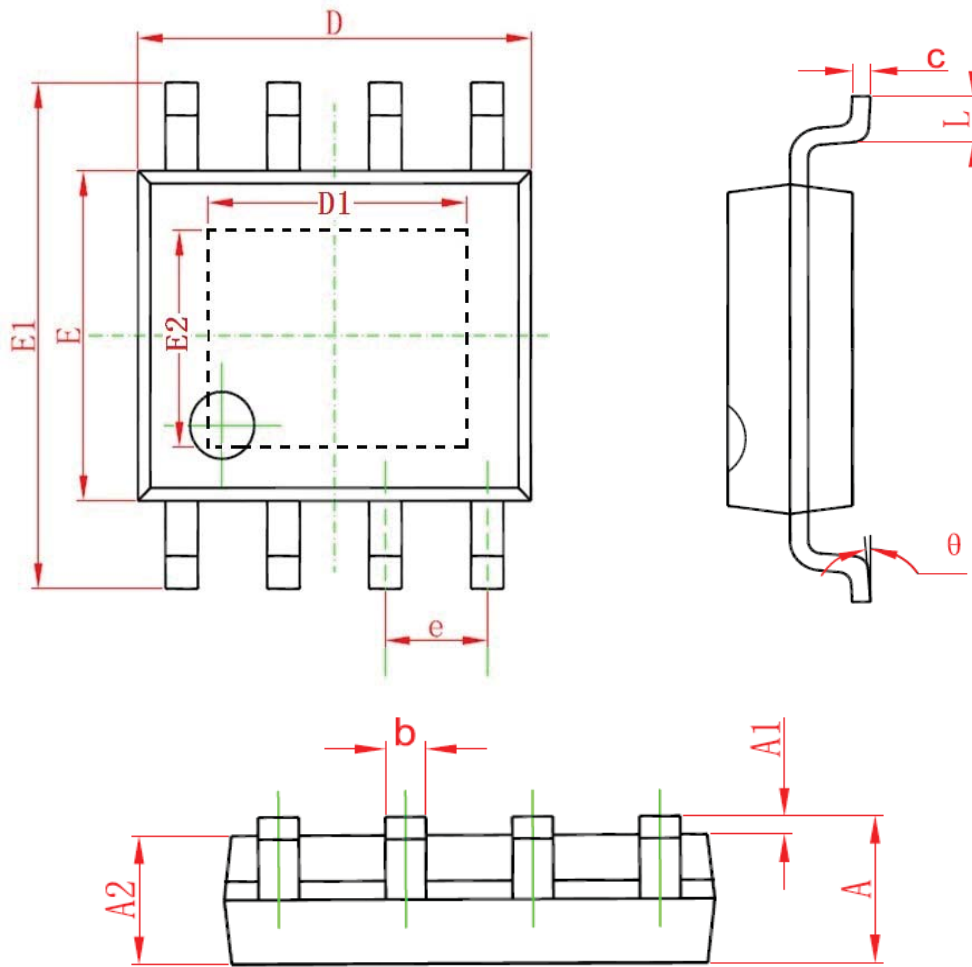

Symbol	Dimensions In Millimeters		Dimensions In Inches	
	Min.	Max.	Min.	Max.
A	1.350	1.750	0.053	0.069
A1	0.100	0.250	0.004	0.010
A2	1.350	1.550	0.053	0.061
b	0.330	0.510	0.013	0.020
c	0.170	0.250	0.006	0.010
D	4.700	5.100	0.185	0.200
D1	3.100	3.500	0.122	0.137
E	3.800	4.000	0.150	0.157
E1	5.800	6.200	0.228	0.244
E2	2.200	2.600	0.086	0.102
e	1.270(BSC)		0.050(BSC)	
L	0.400	1.270	0.016	0.050
θ	0°	8°	0°	8°

单击下面可查看定价，库存，交付和生命周期等信息

[>>LRC\(乐山无线电\)](#)