

LM317L, NCV317L

100 mA Adjustable Output, Positive Voltage Regulator

The LM317L is an adjustable 3-terminal positive voltage regulator capable of supplying in excess of 100 mA over an output voltage range of 1.2 V to 37 V. This voltage regulator is exceptionally easy to use and requires only two external resistors to set the output voltage. Further, it employs internal current limiting, thermal shutdown and safe area compensation, making them essentially blow-out proof.

The LM317L serves a wide variety of applications including local, on card regulation. This device can also be used to make a programmable output regulator, or by connecting a fixed resistor between the adjustment and output, the LM317L can be used as a precision current regulator.

Features

- Output Current in Excess of 100 mA
- Output Adjustable Between 1.2 V and 37 V
- Internal Thermal Overload Protection
- Internal Short Circuit Current Limiting
- Output Transistor Safe-Area Compensation
- Floating Operation for High Voltage Applications
- Standard 3-Lead Transistor Package
- Eliminates Stocking Many Fixed Voltages
- NCV Prefix for Automotive and Other Applications Requiring Unique Site and Control Change Requirements; AEC-Q100 Qualified and PPAP Capable
- These are Pb-Free Devices

Simplified Application

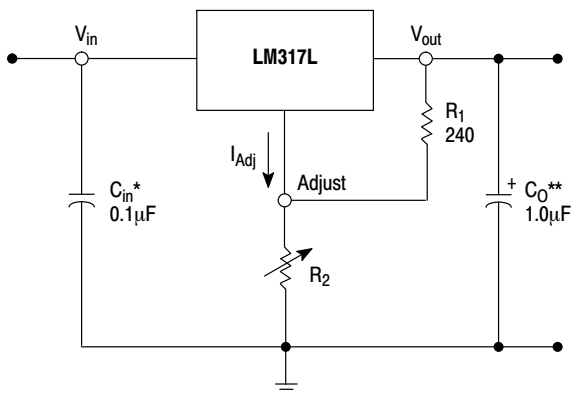

* C_{in} is required if regulator is located an appreciable distance from power supply filter.

** C_O is not needed for stability, however, it does improve transient response.

$$V_{out} = 1.25 V \left(1 + \frac{R_2}{R_1} \right) + I_{Adj} R_2$$

Since I_{Adj} is controlled to less than 100 μA , the error associated with this term is negligible in most applications.



ON Semiconductor®

www.onsemi.com

LOW CURRENT THREE-TERMINAL ADJUSTABLE POSITIVE VOLTAGE REGULATOR



- Pin 1. V_{in}
2. V_{out}
3. V_{out}
4. Adjust
5. N.C.
6. V_{out}
7. V_{out}
8. N.C.

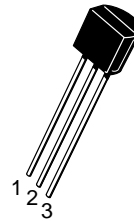

STRAIGHT LEAD
BULK PACK

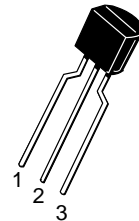

BENT LEAD
TAPE & REEL
AMMO PACK

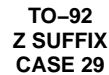

TO-92
Z SUFFIX
CASE 29

- Pin 1. Adjust
2. V_{out}
3. V_{in}

ORDERING INFORMATION

See detailed ordering and shipping information in the package dimensions section on page 9 of this data sheet.

LM317L, NCV317L

MAXIMUM RATINGS

Rating	Symbol	Value	Unit
Input-Output Voltage Differential	$V_I - V_O$	40	Vdc
Power Dissipation Case 29 (TO-92) $T_A = 25^\circ\text{C}$ Thermal Resistance, Junction-to-Ambient Thermal Resistance, Junction-to-Case	P_D $R_{\theta JA}$ $R_{\theta JC}$	Internally Limited 160 83	W $^\circ\text{C/W}$ $^\circ\text{C/W}$
Case 751 (SOIC-8) (Note 1) $T_A = 25^\circ\text{C}$ Thermal Resistance, Junction-to-Ambient Thermal Resistance, Junction-to-Case	P_D $R_{\theta JA}$ $R_{\theta JC}$	Internally Limited 180 45	W $^\circ\text{C/W}$ $^\circ\text{C/W}$
Maximum Junction Temperature	T_{JMAX}	+150	$^\circ\text{C}$
Storage Temperature Range	T_{stg}	-65 to +150	$^\circ\text{C}$

Stresses exceeding those listed in the Maximum Ratings table may damage the device. If any of these limits are exceeded, device functionality should not be assumed, damage may occur and reliability may be affected.

- SOIC-8 Junction-to-Ambient Thermal Resistance is for minimum recommended pad size. Refer to Figure 24 for Thermal Resistance variation versus pad size.
- This device series contains ESD protection and exceeds the following tests:
Human Body Model, 2000 V per MIL STD 883, Method 3015.
Machine Model Method, 200 V.

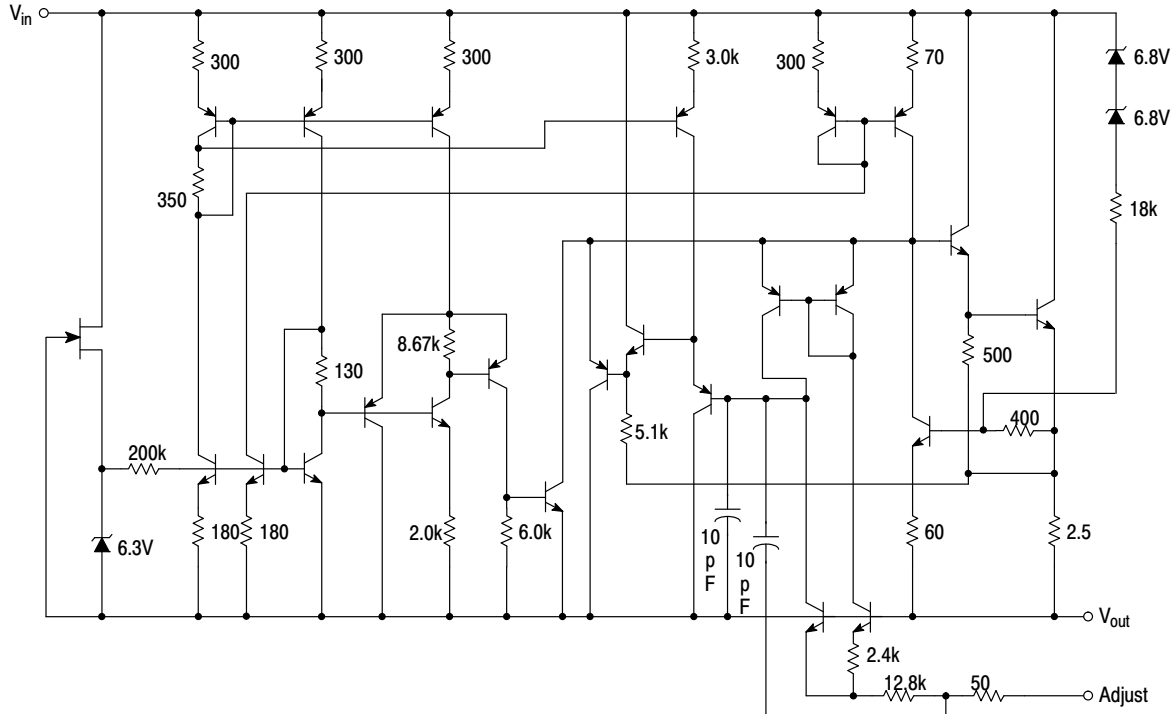

Figure 1. Representative Schematic Diagram

LM317L, NCV317L

ELECTRICAL CHARACTERISTICS

($V_I - V_O = 5.0\text{ V}$; $I_O = 40\text{ mA}$; $T_J = T_{\text{low}}$ to T_{high} (Note 3); I_{max} and P_{max} (Note 4); unless otherwise noted.)

Characteristics	Figure	Symbol	LM317L, LB, NCV317LB			Unit
			Min	Typ	Max	
Line Regulation (Note 5) $T_A = 25^\circ\text{C}$, $3.0\text{ V} \leq V_I - V_O \leq 40\text{ V}$	1	Reg_{line}	–	0.01	0.04	%/V
Load Regulation (Note 5), $T_A = 25^\circ\text{C}$ $10\text{ mA} \leq I_O \leq I_{\text{max}}$ – LM317L $V_O \leq 5.0\text{ V}$ $V_O \geq 5.0\text{ V}$	2	Reg_{load}	– –	5.0 0.1	25 0.5	mV % V_O
Adjustment Pin Current	3	I_{Adj}	–	50	100	μA
Adjustment Pin Current Change $2.5\text{ V} \leq V_I - V_O \leq 40\text{ V}$, $P_D \leq P_{\text{max}}$ $10\text{ mA} \leq I_O \leq I_{\text{max}}$ – LM317L	1, 2	ΔI_{Adj}	–	0.2	5.0	μA
Reference Voltage $3.0\text{ V} \leq V_I - V_O \leq 40\text{ V}$, $P_D \leq P_{\text{max}}$ $10\text{ mA} \leq I_O \leq I_{\text{max}}$ – LM317L	3	V_{ref}	1.20	1.25	1.30	V
Line Regulation (Note 5), $3.0\text{ V} \leq V_I - V_O \leq 40\text{ V}$	1	Reg_{line}	–	0.02	0.07	%/V
Load Regulation (Note 5) $10\text{ mA} \leq I_O \leq I_{\text{max}}$ – LM317L $V_O \leq 5.0\text{ V}$ $V_O \geq 5.0\text{ V}$	2	Reg_{load}	– –	20 0.3	70 1.5	mV % V_O
Temperature Stability ($T_{\text{low}} \leq T_J \leq T_{\text{high}}$)	3	T_S	–	0.7	–	% V_O
Minimum Load Current to Maintain Regulation ($V_I - V_O = 40\text{ V}$)	3	I_{Lmin}	–	3.5	10	mA
Maximum Output Current $V_I - V_O \leq 6.25\text{ V}$, $P_D \leq P_{\text{max}}$, Z Package $V_I - V_O \leq 40\text{ V}$, $P_D \leq P_{\text{max}}$, $T_A = 25^\circ\text{C}$, Z Package	3	I_{max}	100 –	200 20	– –	mA
RMS Noise, % of V_O $T_A = 25^\circ\text{C}$, $10\text{ Hz} \leq f \leq 10\text{ kHz}$	–	N	–	0.003	–	% V_O
Ripple Rejection (Note 6) $V_O = 1.2\text{ V}$, $f = 120\text{ Hz}$ $C_{\text{Adj}} = 10\text{ }\mu\text{F}$, $V_O = 10.0\text{ V}$	4	RR	60 –	80 80	– –	dB
Thermal Shutdown (Note 7)	–	–	–	180	–	$^\circ\text{C}$
Long Term Stability, $T_J = T_{\text{high}}$ (Note 8) $T_A = 25^\circ\text{C}$ for Endpoint Measurements	3	S	–	0.3	1.0	%/1.0 k Hrs.

3. T_{low} to $T_{\text{high}} = 0^\circ$ to $+125^\circ\text{C}$ for LM317L -40° to $+125^\circ\text{C}$ for LM317LB, NCV317LB

4. $I_{\text{max}} = 100\text{ mA}$ $P_{\text{max}} = 625\text{ mW}$

5. Load and line regulation are specified at constant junction temperature. Changes in V_O due to heating effects must be taken into account separately. Pulse testing with low duty cycle is used.

6. C_{Adj} , when used, is connected between the adjustment pin and ground.

7. Thermal characteristics are not subject to production test.

8. Since Long-Term Stability cannot be measured on each device before shipment, this specification is an engineering estimate of average stability from lot to lot.

LM317L, NCV317L

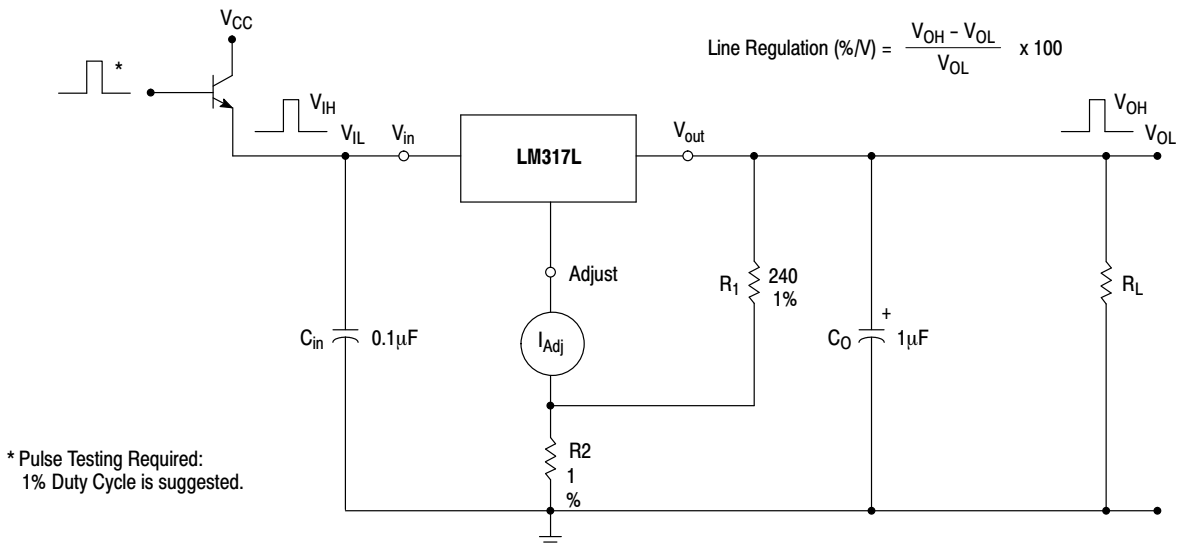

Figure 2. Line Regulation and ΔI_{Adj} /Line Test Circuit

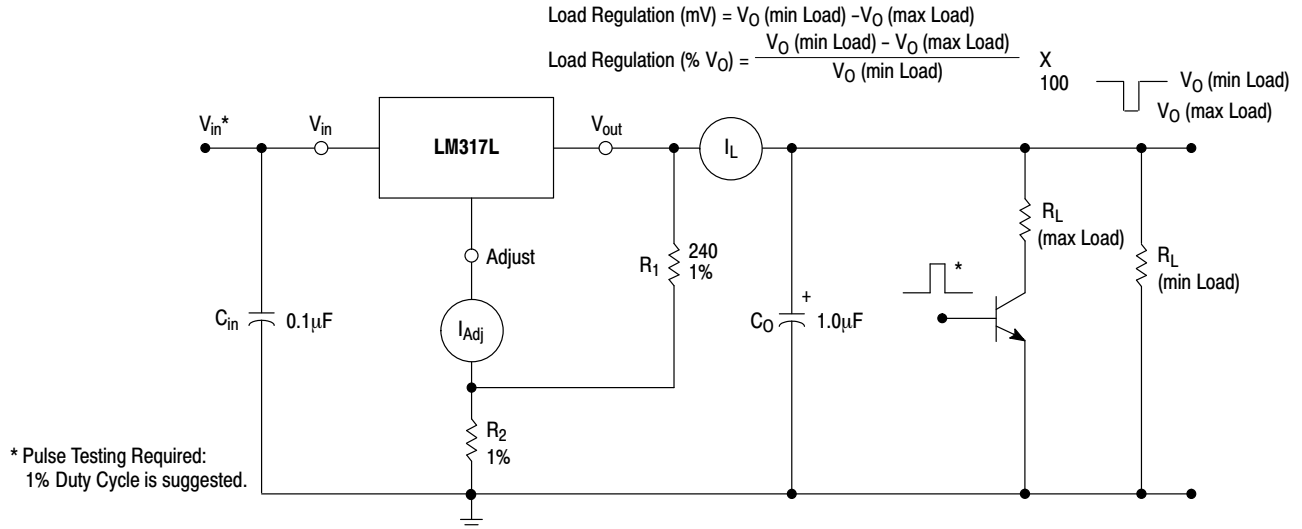

Figure 3. Load Regulation and ΔI_{Adj} /Load Test Circuit

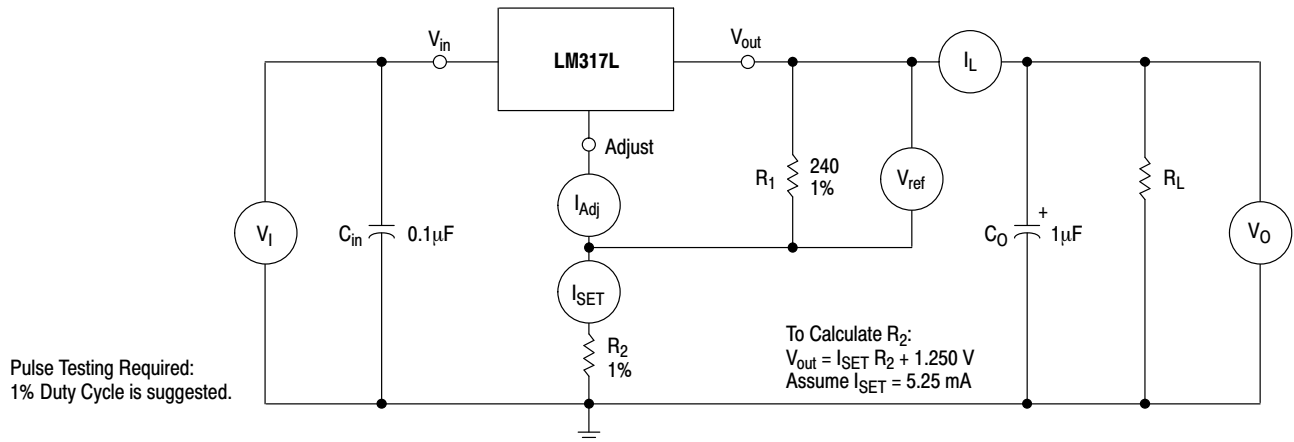
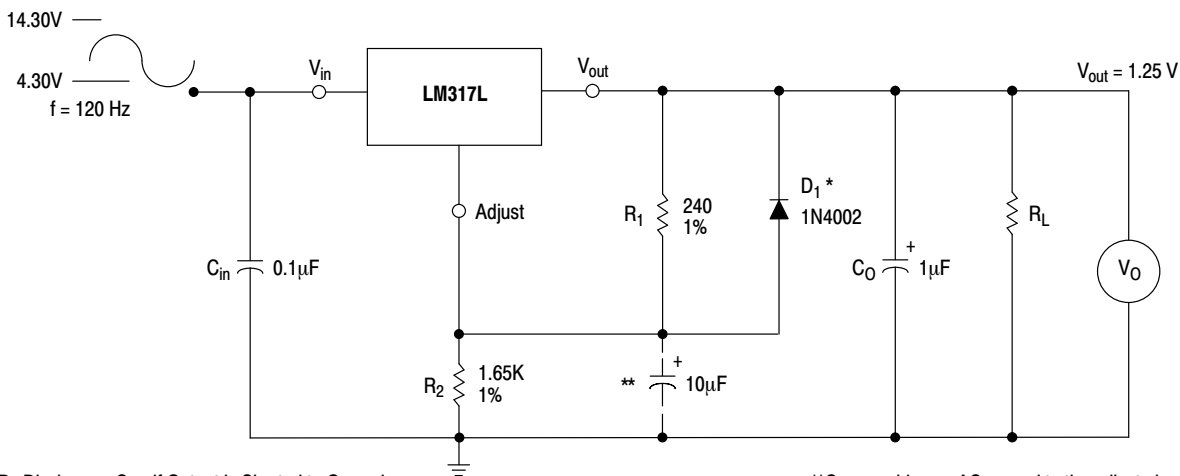

Figure 4. Standard Test Circuit

LM317L, NCV317L



* D_1 Discharges C_{Adj} if Output is Shorted to Ground.

** C_{Adj} provides an AC ground to the adjust pin.

Figure 5. Ripple Rejection Test Circuit

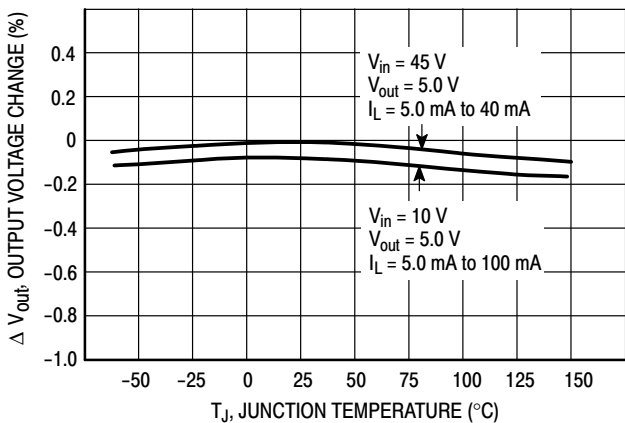

Figure 6. Load Regulation

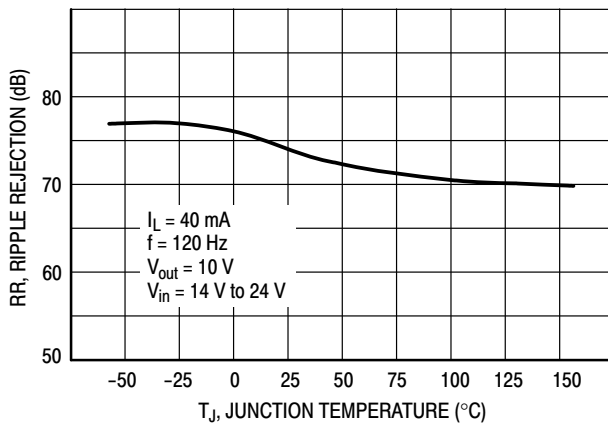

Figure 7. Ripple Rejection

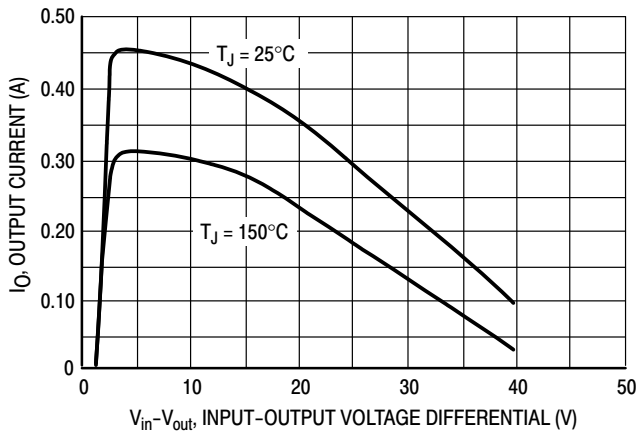

Figure 8. Current Limit

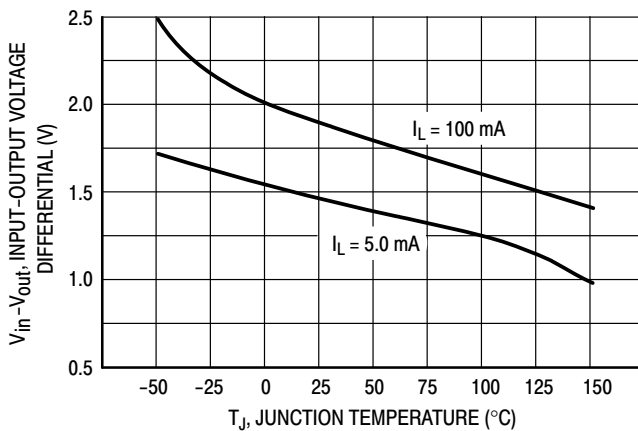

Figure 9. Dropout Voltage

LM317L, NCV317L

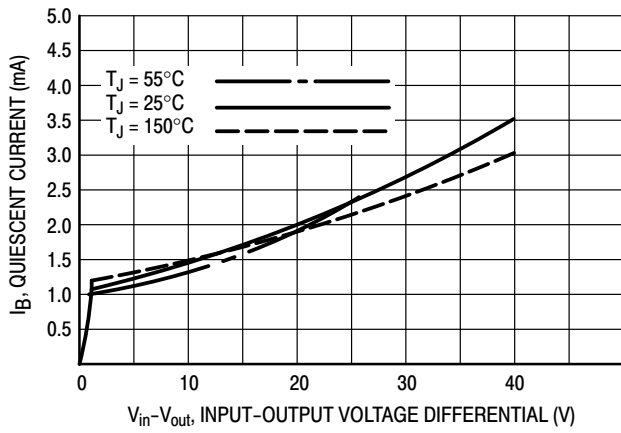

Figure 10. Minimum Operating Current

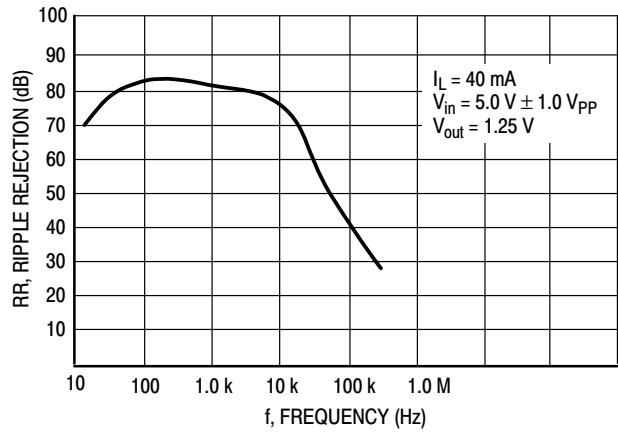

Figure 11. Ripple Rejection versus Frequency

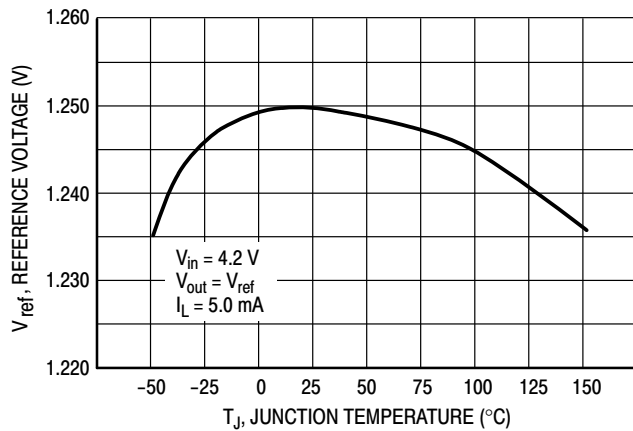

Figure 12. Temperature Stability

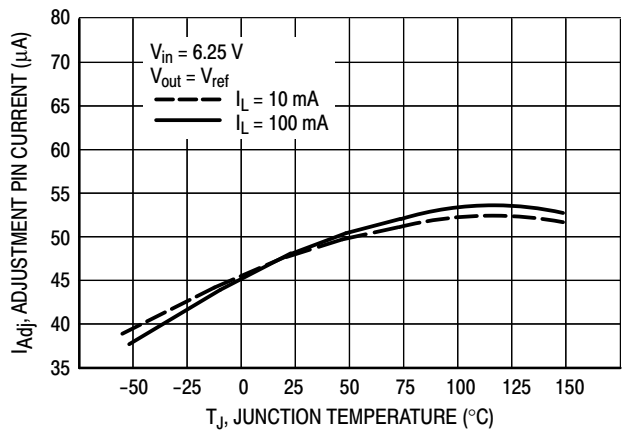

Figure 13. Adjustment Pin Current

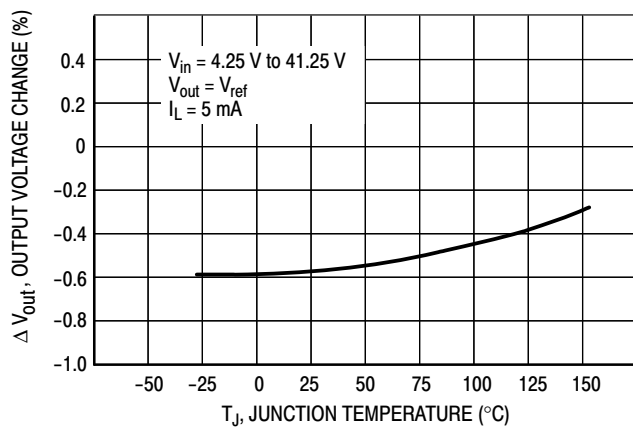

Figure 14. Line Regulation

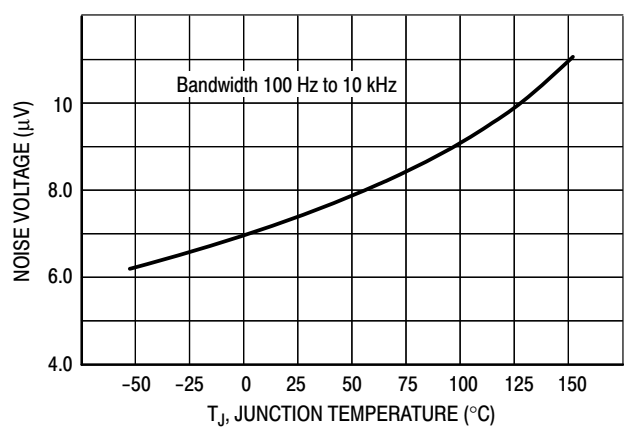

Figure 15. Output Noise

LM317L, NCV317L

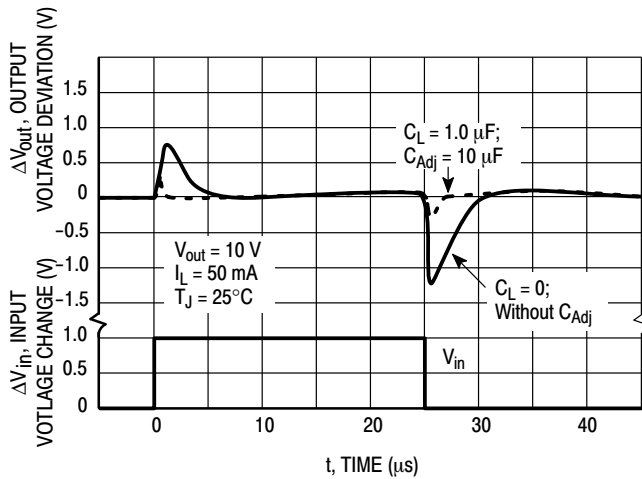

Figure 16. Line Transient Response

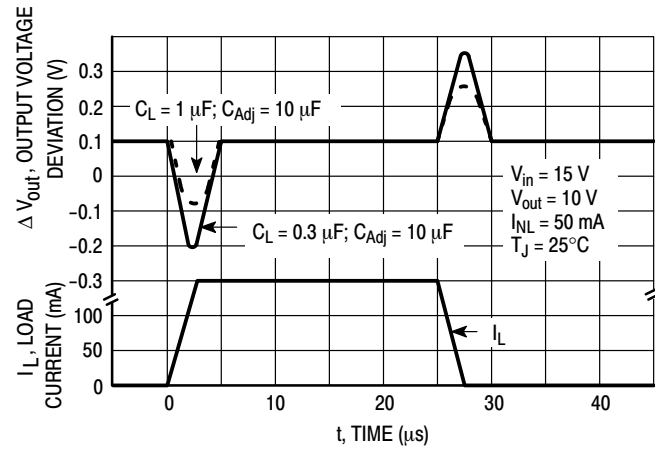

Figure 17. Load Transient Response

APPLICATIONS INFORMATION

Basic Circuit Operation

The LM317L is a 3-terminal floating regulator. In operation, the LM317L develops and maintains a nominal 1.25 V reference (V_{ref}) between its output and adjustment terminals. This reference voltage is converted to a programming current (I_{PROG}) by R_1 (see Figure 13), and this constant current flows through R_2 to ground. The regulated output voltage is given by:

$$V_{out} = V_{ref} \left(1 + \frac{R_2}{R_1} \right) + I_{Adj} R_2$$

Since the current from the adjustment terminal (I_{Adj}) represents an error term in the equation, the LM317L was designed to control I_{Adj} to less than 100 μA and keep it constant. To do this, all quiescent operating current is returned to the output terminal. This imposes the requirement for a minimum load current. If the load current is less than this minimum, the output voltage will rise.

Since the LM317L is a floating regulator, it is only the voltage differential across the circuit which is important to performance, and operation at high voltages with respect to ground is possible.

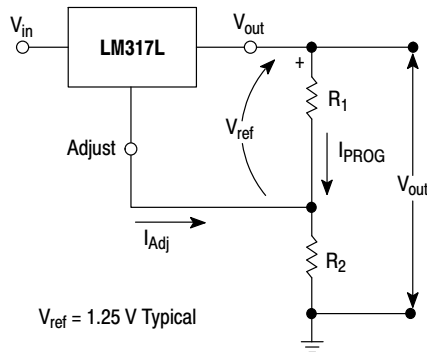

Figure 18. Basic Circuit Configuration

Load Regulation

The LM317L is capable of providing extremely good load regulation, but a few precautions are needed to obtain maximum performance. For best performance, the programming resistor (R_1) should be connected as close to the regulator as possible to minimize line drops which effectively appear in series with the reference, thereby degrading regulation. The ground end of R_2 can be returned near the load ground to provide remote ground sensing and improve load regulation.

External Capacitors

A 0.1 μF disc or 1.0 μF tantalum input bypass capacitor (C_{in}) is recommended to reduce the sensitivity to input line impedance.

The adjustment terminal may be bypassed to ground to improve ripple rejection. This capacitor (C_{Adj}) prevents ripple from being amplified as the output voltage is increased. A 10 μF capacitor should improve ripple rejection about 15 dB at 120 Hz in a 10 V application.

Although the LM317L is stable with no output capacitance, like any feedback circuit, certain values of external capacitance can cause excessive ringing. An output capacitance (C_O) in the form of a 1.0 μF tantalum or 25 μF aluminum electrolytic capacitor on the output swamps this effect and insures stability.

Protection Diodes

When external capacitors are used with any IC regulator it is sometimes necessary to add protection diodes to prevent the capacitors from discharging through low current points into the regulator.

Figure 14 shows the LM317L with the recommended protection diodes for output voltages in excess of 25 V or high capacitance values ($C_O > 10 \mu\text{F}$, $C_{\text{Adj}} > 5.0 \mu\text{F}$). Diode D_1 prevents C_O from discharging thru the IC during an input short circuit. Diode D_2 protects against capacitor C_{Adj} discharging through the IC during an output short circuit. The combination of diodes D_1 and D_2 prevents C_{Adj} from discharging through the IC during an input short circuit.

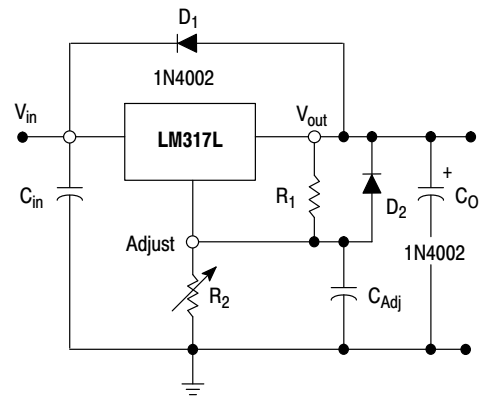

Figure 19. Voltage Regulator with Protection Diodes

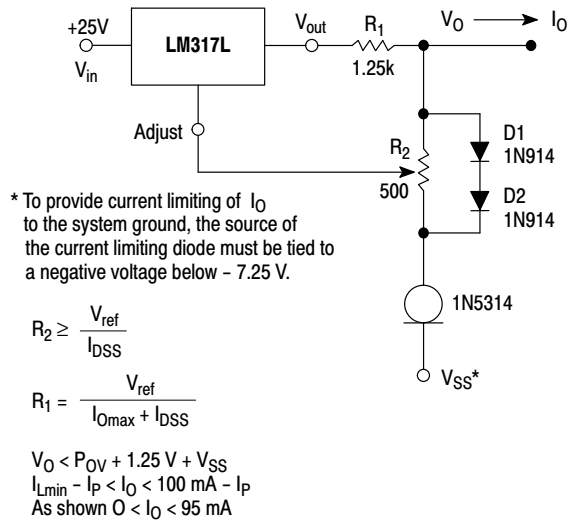
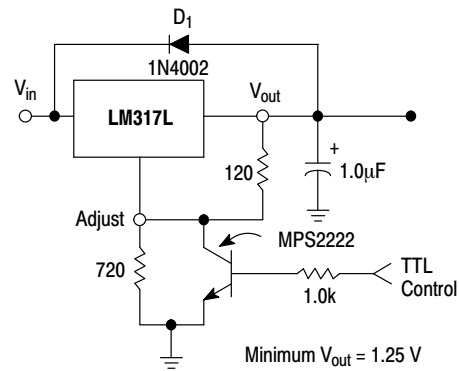

Figure 20. Adjustable Current Limiter



D_1 protects the device during an input short circuit.

Figure 21. 5.0 V Electronic Shutdown Regulator

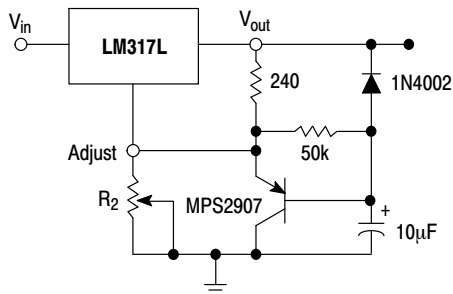
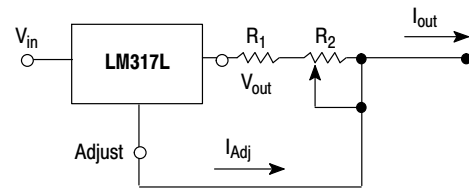

Figure 22. Slow Turn-On Regulator



$$I_{\text{outmax}} = \left(\frac{V_{\text{ref}}}{R_1} \right) + I_{\text{Adj}} \cong \frac{1.25 \text{ V}}{R_1}$$

$$I_{\text{outmax}} = \left(\frac{V_{\text{ref}}}{R_1 + R_2} \right) + I_{\text{Adj}} \cong \frac{1.25 \text{ V}}{R_1 + R_2}$$

$5.0 \text{ mA} < I_{\text{out}} < 100 \text{ mA}$

Figure 23. Current Regulator

LM317L, NCV317L

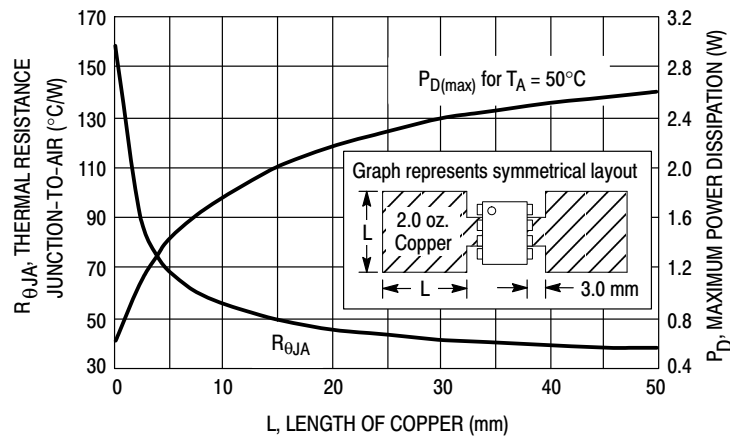

Figure 24. SOP-8 Thermal Resistance and Maximum Power Dissipation versus P.C.B. Copper Length

ORDERING INFORMATION

Device	Operating Temperature Range	Package	Shipping [†]
LM317LBDG	$T_J = -40^{\circ}\text{C}$ to $+125^{\circ}\text{C}$	SOIC-8 (Pb-Free)	98 Units / Rail
LM317LBDR2G		SOIC-8 (Pb-Free)	2500/Tape & Reel
LM317LBZG		TO-92 (Pb-Free)	2000 Units / Bag
LM317LBZRAG		TO-92 (Pb-Free)	2000 Tape & Reel
LM317LBZRPG		TO-92 (Pb-Free)	2000 Ammo Pack
NCV317LBDG*		SOIC-8 (Pb-Free)	98 Units / Rail
NCV317LBDR2G*		SOIC-8 (Pb-Free)	2500/Tape & Reel
NCV317LBZG*		TO-92 (Pb-Free)	2000 Units / Bag
NCV317LBZRAG*		TO-92 (Pb-Free)	2000 Tape & Reel
LM317LDG	$T_J = 0^{\circ}\text{C}$ to $+125^{\circ}\text{C}$	SOIC-8 (Pb-Free)	98 Units / Rail
LM317LDR2G		SOIC-8 (Pb-Free)	2500/Tape & Reel
LM317LZG		TO-92 (Pb-Free)	2000 Units / Bag
LM317LZRAG		TO-92 (Pb-Free)	2000 Tape & Reel
LM317LZREG		TO-92 (Pb-Free)	2000 Tape & Reel
LM317LZRMG		TO-92 (Pb-Free)	2000 Ammo Pack
LM317LZRPG		TO-92 (Pb-Free)	2000 Ammo Pack

[†]For information on tape and reel specifications, including part orientation and tape sizes, please refer to our Tape and Reel Packaging Specifications Brochure, BRD8011/D.

*NCV devices: $T_{low} = -40^{\circ}\text{C}$, $T_{high} = +125^{\circ}\text{C}$. Guaranteed by design. NCV Prefix for Automotive and Other Applications Requiring Unique Site and Control Change Requirements; AEC-Q100 Qualified and PPAP Capable.

LM317L, NCV317L

PACKAGE DIMENSIONS

TO-92 (TO-226)
Z SUFFIX
CASE 29-11
ISSUE AM

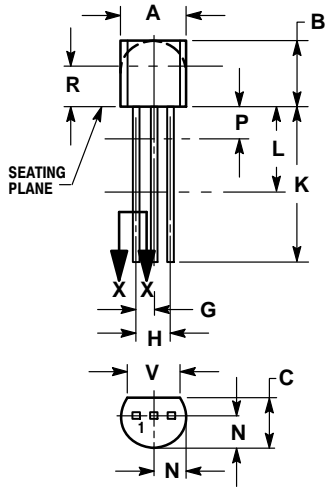

STRAIGHT LEAD
BULK PACK

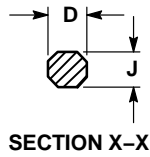

SECTION X-X

NOTES:

1. DIMENSIONING AND TOLERANCING PER ANSI Y14.5M, 1982.
2. CONTROLLING DIMENSION: INCH.
3. CONTOUR OF PACKAGE BEYOND DIMENSION R IS UNCONTROLLED.
4. LEAD DIMENSION IS UNCONTROLLED IN P AND BEYOND DIMENSION K MINIMUM.

DIM	INCHES		MILLIMETERS	
	MIN	MAX	MIN	MAX
A	0.175	0.205	4.45	5.20
B	0.170	0.210	4.32	5.33
C	0.125	0.165	3.18	4.19
D	0.016	0.021	0.407	0.533
G	0.045	0.055	1.15	1.39
H	0.095	0.105	2.42	2.66
J	0.015	0.020	0.39	0.50
K	0.500	---	12.70	---
L	0.250	---	6.35	---
N	0.080	0.105	2.04	2.66
P	---	0.100	---	2.54
R	0.115	---	2.93	---
V	0.135	---	3.43	---

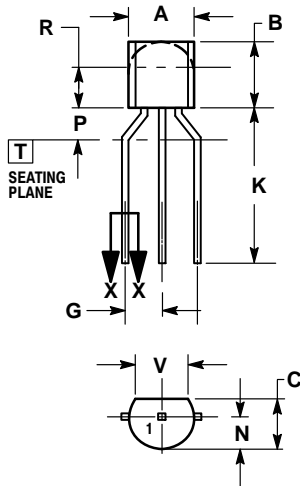

BENT LEAD
TAPE & REEL
AMMO PACK

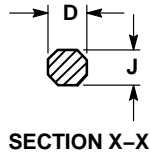

SECTION X-X

NOTES:

1. DIMENSIONING AND TOLERANCING PER ASME Y14.5M, 1994.
2. CONTROLLING DIMENSION: MILLIMETERS.
3. CONTOUR OF PACKAGE BEYOND DIMENSION R IS UNCONTROLLED.
4. LEAD DIMENSION IS UNCONTROLLED IN P AND BEYOND DIMENSION K MINIMUM.

DIM	MILLIMETERS	
	MIN	MAX
A	4.45	5.20
B	4.32	5.33
C	3.18	4.19
D	0.40	0.54
G	2.40	2.80
J	0.39	0.50
K	12.70	---
N	2.04	2.66
P	1.50	4.00
R	2.93	---
V	3.43	---

LM317L, NCV317L

PACKAGE DIMENSIONS

SOIC-8 NB
D SUFFIX
CASE 751-07
ISSUE AK

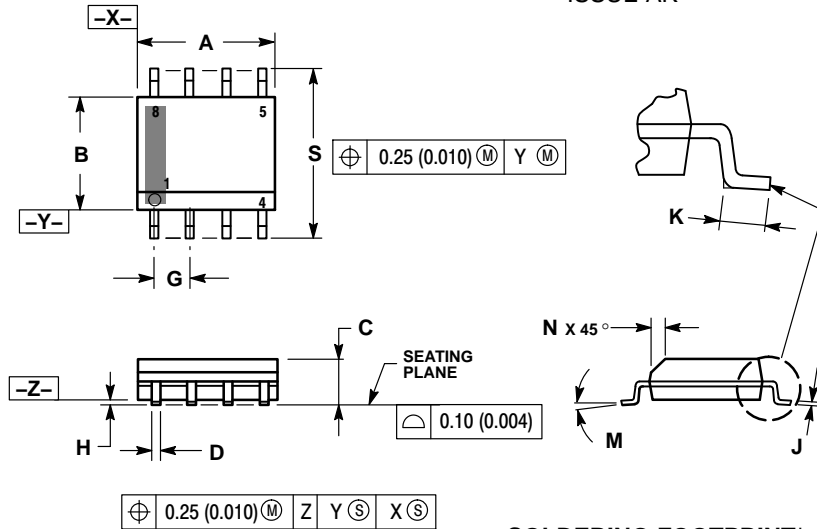

NOTES:

1. DIMENSIONING AND TOLERANCING PER ANSI Y14.5M, 1982.
2. CONTROLLING DIMENSION: MILLIMETER.
3. DIMENSION A AND B DO NOT INCLUDE MOLD PROTRUSION.
4. MAXIMUM MOLD PROTRUSION 0.15 (0.006) PER SIDE.
5. DIMENSION D DOES NOT INCLUDE DAMBAR PROTRUSION. ALLOWABLE DAMBAR PROTRUSION SHALL BE 0.127 (0.005) TOTAL IN EXCESS OF THE D DIMENSION AT MAXIMUM MATERIAL CONDITION.
6. 751-01 THRU 751-06 ARE OBSOLETE. NEW STANDARD IS 751-07.

DIM	MILLIMETERS		INCHES	
	MIN	MAX	MIN	MAX
A	4.80	5.00	0.189	0.197
B	3.80	4.00	0.150	0.157
C	1.35	1.75	0.053	0.069
D	0.33	0.51	0.013	0.020
G	1.27 BSC		0.050 BSC	
H	0.10	0.25	0.004	0.010
J	0.19	0.25	0.007	0.010
K	0.40	1.27	0.016	0.050
M	0°	8°	0°	8°
N	0.25	0.50	0.010	0.020
S	5.80	6.20	0.228	0.244

SOLDERING FOOTPRINT*

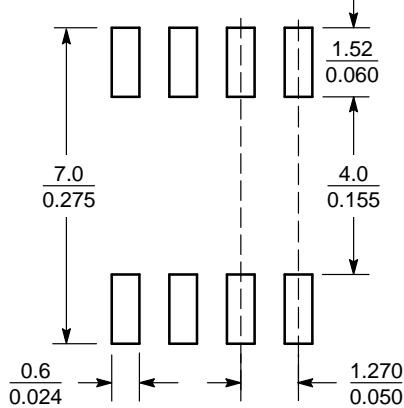

SCALE 6:1 (mm/inches)

*For additional information on our Pb-Free strategy and soldering details, please download the ON Semiconductor Soldering and Mounting Techniques Reference Manual, SOLDERRM/D.

ON Semiconductor and are trademarks of Semiconductor Components Industries, LLC dba ON Semiconductor or its subsidiaries in the United States and/or other countries. ON Semiconductor owns the rights to a number of patents, trademarks, copyrights, trade secrets, and other intellectual property. A listing of ON Semiconductor's product/patent coverage may be accessed at www.onsemi.com/site/pdf/Patent-Marking.pdf. ON Semiconductor reserves the right to make changes without further notice to its products herein. ON Semiconductor makes no warranty, representation or guarantee regarding the suitability of its products for any particular purpose, nor does ON Semiconductor assume any liability arising out of the application or use of any product or circuit, and specifically disclaims any and all liability, including without limitation special, consequential or incidental damages. Buyer is responsible for its products and applications using ON Semiconductor products, including compliance with all laws, regulations and safety requirements or standards, regardless of any support or applications information provided by ON Semiconductor. "Typical" parameters which may be provided in ON Semiconductor data sheets and/or specifications can and do vary in different applications and actual performance may vary over time. All operating parameters, including "Typicals" must be validated for each customer application by customer's technical experts. ON Semiconductor does not convey any license under its patent rights nor the rights of others. ON Semiconductor products are not designed, intended, or authorized for use as a critical component in life support systems or any FDA Class 3 medical devices or medical devices with a same or similar classification in a foreign jurisdiction or any devices intended for implantation in the human body. Should Buyer purchase or use ON Semiconductor products for any such unintended or unauthorized application, Buyer shall indemnify and hold ON Semiconductor and its officers, employees, subsidiaries, affiliates, and distributors harmless against all claims, costs, damages, and expenses, and reasonable attorney fees arising out of, directly or indirectly, any claim of personal injury or death associated with such unintended or unauthorized use, even if such claim alleges that ON Semiconductor was negligent regarding the design or manufacture of the part. ON Semiconductor is an Equal Opportunity/Affirmative Action Employer. This literature is subject to all applicable copyright laws and is not for resale in any manner.

PUBLICATION ORDERING INFORMATION

LITERATURE FULFILLMENT:
Literature Distribution Center for ON Semiconductor
19521 E. 32nd Pkwy, Aurora, Colorado 80011 USA
Phone: 303-675-2175 or 800-344-3860 Toll Free USA/Canada
Fax: 303-675-2176 or 800-344-3867 Toll Free USA/Canada
Email: orderlit@onsemi.com

N. American Technical Support: 800-282-9855 Toll Free
USA/Canada
Europe, Middle East and Africa Technical Support:
Phone: 421 33 790 2910
Japan Customer Focus Center
Phone: 81-3-5817-1050

ON Semiconductor Website: www.onsemi.com
Order Literature: <http://www.onsemi.com/orderlit>

For additional information, please contact your local Sales Representative

单击下面可查看定价，库存，交付和生命周期等信息

[>>ON Semiconductor\(安森美\)](#)