



Title of Document: <b>HANDLING MANUAL</b>	Issue No. CHM-1-2182	Rev. 16
Customer:	Issue date: 22 May 2006	
Title subject: CPT Connector	Revision date: 4 March 2019	

This handling manual describes the usage points and the terminal crimping operation of the CPT connector. Be sure to read this manual thoroughly before crimping operation, and then keep it at the place where operators who adjust the crimping tool and perform crimping operation can see it at any time.

C O N T E N T S

	Page
1. Part Name, Model Number and Parts Identification.....	2
1-1 Part name and model No. ....	2
1-2 Parts identification .....	2
2. Recommended PC Board Pattern Layout.....	4
3. Precaution for Mounting on PC Board .....	4
4. Storage .....	5
4-1 Male assembly .....	5
4-2 Female assembly .....	5
4-3 Female terminal.....	5
5. Applicable Wire.....	5
6. Crimping Tool .....	5
7. Crimping Operation .....	6
7-1 Wire strip .....	6
7-2 Crimping .....	6
7-3 Precautions for the storage and the handling of the crimped terminal.....	12
8. Harness Assembly Operation.....	12
8-1 Inserting the female terminal into the housing .....	12
8-2 Locking the retainer.....	13
8-3 Releasing the retainer .....	14
8-4 Extracting the female terminal from the housing .....	15
8-5 Electrical continuity check .....	15
8-6 In wire handling .....	16
9. Mating and Unmating Connector.....	17
9-1 Mating the connector.....	17
9-2 Unmating the connector .....	18
10. Caution for handling carrier tape .....	18

Prepared by: <i>M. Kawarasaki</i>	Checked by: <i>M. Araki</i>	Reviewed by: -	Approved by: <i>H. Tomimoto</i>
--------------------------------------	--------------------------------	-------------------	------------------------------------

<b>JST</b>	Title subject: CPT connector	No. CHM-1-2182
------------	------------------------------	----------------

1. Part Name, Model Number and Parts Identification

1-1 Part name and model No.

The name of this product is CPT connector, and it consists of following each part as shown in Table-1 and Fig.-1.

Table-1

Part name		JST model No.
Male assembly	Top entry type (2, 8 and 12 circuits)	BM(**)B-CPTK-(%%)(\$\$)-TB
	Side entry type (2, 4, 8, 12, 16, and 20 circuits)	SM(**)B(##)-CPTK-(%%)(\$\$)-TB
	Male housing	_____
	Male terminal	_____
	Reinforcing tab	_____
	Suction cap	_____
Female assembly (2, 4, 8, 12, 16, and 20 circuits)		(**)CPT-B(##)-(%%)(\$\$)
	Female housing	_____
	Retainer	_____
Female terminal		SCPT-A021GF-0.5

- Note<sub>1</sub>: “%%” denotes the alteration.
- Note<sub>2</sub>: “\$\$” denotes the code.
- Note<sub>3</sub>: “\*\*” denotes the circuit number.
- Note<sub>4</sub>: “##” denotes the difference of the specification.

1-2 Parts identification

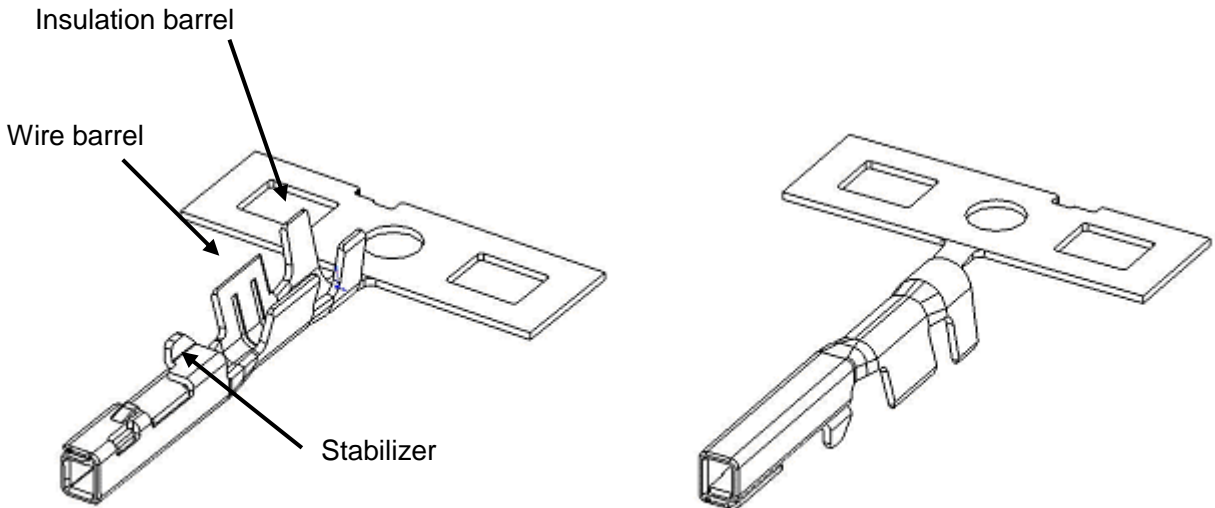
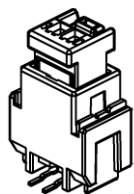

Fig. 1-1: CPT connector's components

<b>JST</b>	Title subject: CPT connector	No. CHM-1-2182
------------	------------------------------	----------------

Top entry type



For 2 circuits

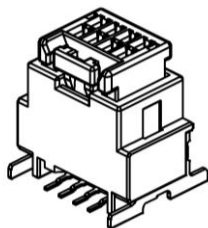

For 8 circuits

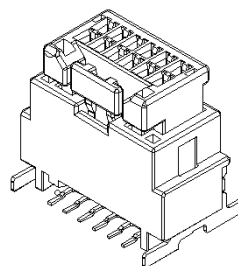

For 12 circuits

Side entry type

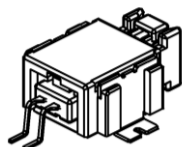

For 2 circuits

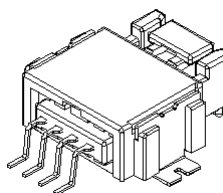

For 4 circuits (Code A and B)

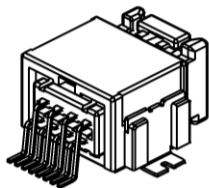

For 8 circuits

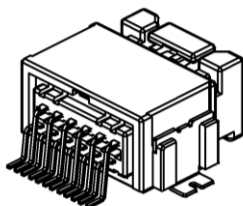

For 12 circuits

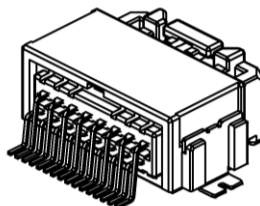

For 16 circuits

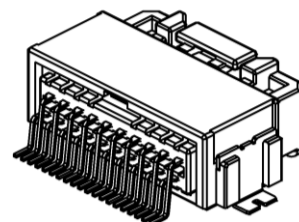

For 20 circuits

Fig. 1-2: CPT connector's components

<b>JST</b>	Title subject: CPT connector	No. CHM-1-2182
------------	------------------------------	----------------

2. Recommended PC Board Pattern Layout  
 Pattern layouts of each circuit are shown below. (Fig.-2)

Top entry type:

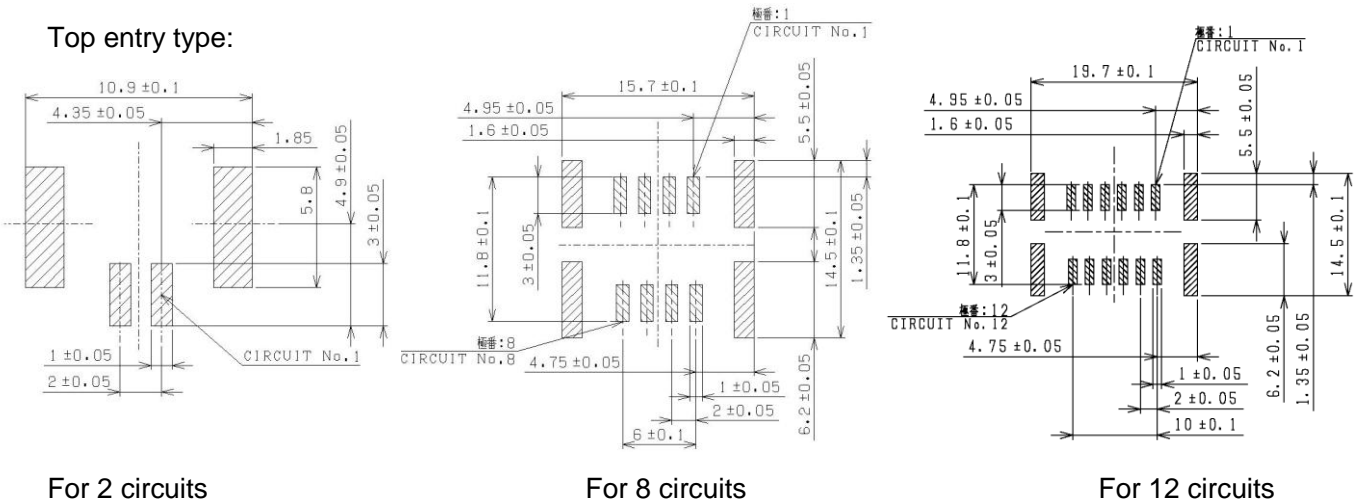

For 2 circuits

For 8 circuits

For 12 circuits

Side entry type:

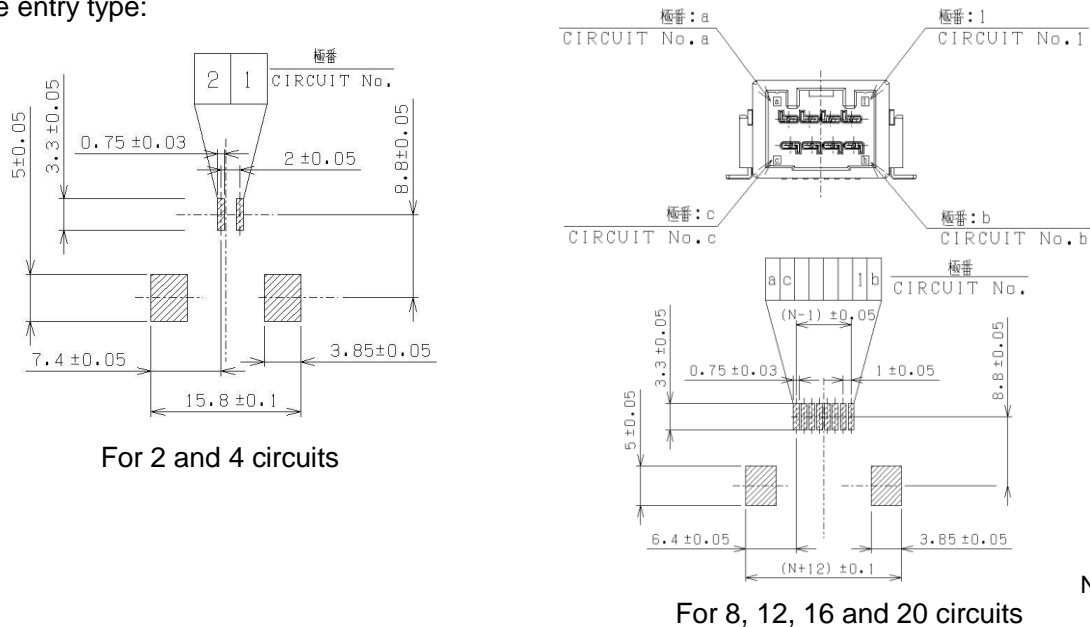

For 2 and 4 circuits

For 8, 12, 16 and 20 circuits

N=Circuit No.

Fig.-2: Pattern layout of each circuit

3. Precaution for Mounting on PC Board

We recommend soldering according to the following condition. However, as the recommended reflow temperature varies depending on soldering materials, such as solder paste, make sure of soldering in advance.

Table-2: Reflow condition

Item	Condition	
Top temperature gradient	5 °C/sec. max.	
Pre-heating	Temperature	160 ~ 180 °C
	Period	100 ± 20 sec.
Period over 200°C	80 ± 10 sec.	
Period over 250°C	50 sec. max.	
Top temperature achieved (Moment)	260°C	
Atmosphere inside soldering bath	N <sub>2</sub> (Concentration of oxygen: 500 ppm)	
Metal mask thickness	180 μm	

<b>JST</b>	Title subject: CPT connector	No. CHM-1-2182
------------	------------------------------	----------------

4. Storage

Store the CPT connector in a carton box and in a clean room with ordinary temperature (5°C ~ 35°C) and relative humidity (40% ~ 60%).

4-1 Male assembly

Handle the male pin with care not to damage because the male side of the CPT connector has the exposed spring. Therefore, the male assembly is wound on the reel for it and shipped.

Do not take it out from the carton box until it is used, but keep the box in a safe place.

The storage limitation is 180 days until soldering.

4-2 Female assembly

The female assembly is put into a vinyl bag and packed into a carton box, and then shipped out.

Do not take it out from carton box until it is used, but keep the box in a safe place.

4-3 Female terminal

In order to keep the female terminal clean and safe, they are wound on the reel with paper covering.

As the female terminal reel is packed into the carton box for safety during the transportation and the storage, do not take it out from the box until crimping operation.

5. Applicable Wire

Table-3

Wire	Wire size
AESSX0.3F	0.3 mm <sup>2</sup> (AWG #22)

Note: Special wires other than the above one cannot be used in principle. When using special wires, please contact JST.

6. Crimping Tool

Table-4

Part name	Model No.
Semi-automatic press	AP-K2N
Crimping applicator set (Crimping applicator with die)	APLMK SCPT-A021-05
Crimping applicator	MKS-L
Die set	MK/SCPT-A021-05

When crimping operation is conducted by using other than the above die set, JST cannot guarantee the connector's performance.

<b>JST</b>	Title subject: CPT connector	No. CHM-1-2182
------------	------------------------------	----------------

## 7. Crimping Operation

Before crimping operation, be sure to check that the combination of the terminal, wires, and the crimping die is correct.

As the gold-plated terminal tends to cause more troubles such as biting into the face of the crimper dies rather than the tin-plated terminal, lubricate JST specified oil to the terminal as shown below during crimping. (Oil: Nihon Kohsakyu Co., Ltd.-made blanking oil, G6316)

For lubricating oil, use a JST-specified lubricator and coat oil throughout the barrel bottom surface and the carrier of the terminal. At this time, be careful not to loose the coating brush of the lubricator which coats oil, because coating becomes insufficient.

Moreover, in case that an interval is made due to pause until crimping after oil lubrication, lubricate oil before crimping.

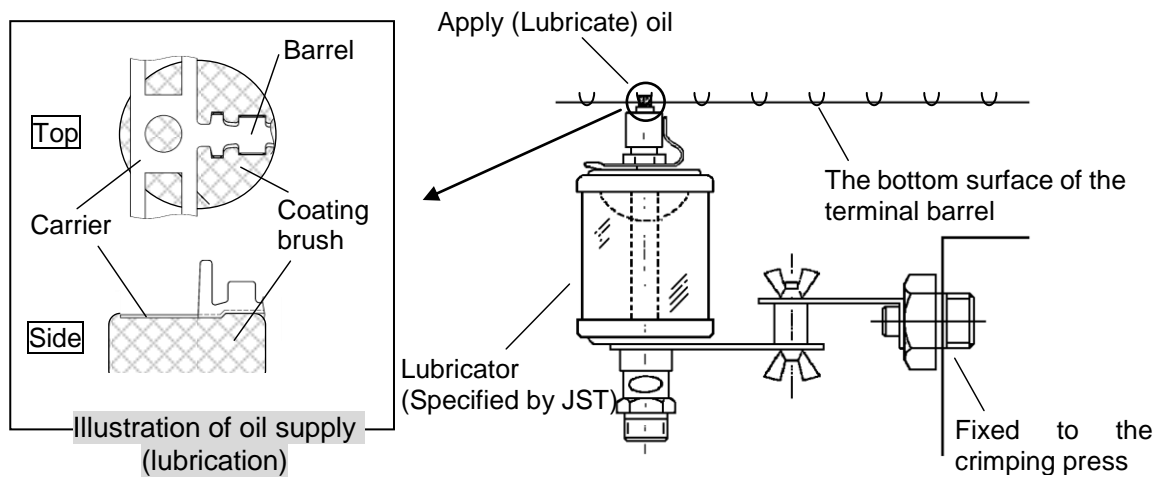

Fig.-3

### 7-1 Wire strip

When the wire is striped, do not damage or cut off the wire conductors. As the wire strip length differs depending on wire type, crimping method, etc. decide the best wire strip length considering the processing condition. (Fig.-4)

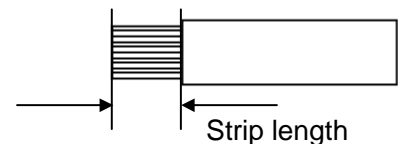

Fig.-4

Reference value of wire strip length: 3.3 mm

### 7-2 Crimping

#### 7-2-1 Precaution for handling applicator

- Precautions for crimping operation are shown in Fig.5. Crimp the wire as close as possible to the terminal crimping part. (See "Good example") Do not crimp the wire at the position which is far from the terminal's crimping part or set the wire diagonally (See "Not good example 1, 2"), because such handling may cause the defective crimping shown in 7-2-2, "Example of defective crimping (Fig. 11)"
- Do not crimp without terminal and twice, because they may cause outstanding burr at the crimped part and may lead to the abrasion of the crimping die quickly.
- As cutting residue (powder), etc. adhered to the crimping die part affects the life of the dies, clean the crimping part occasionally and conduct appropriate crimping.
- As the abrasion of the crimping die and insufficient adjustment of the applicator may cause defective crimping appearance, do not fail to conduct daily inspection.



<b>JST</b>	Title subject: CPT connector	No. CHM-1-2182
------------	------------------------------	----------------

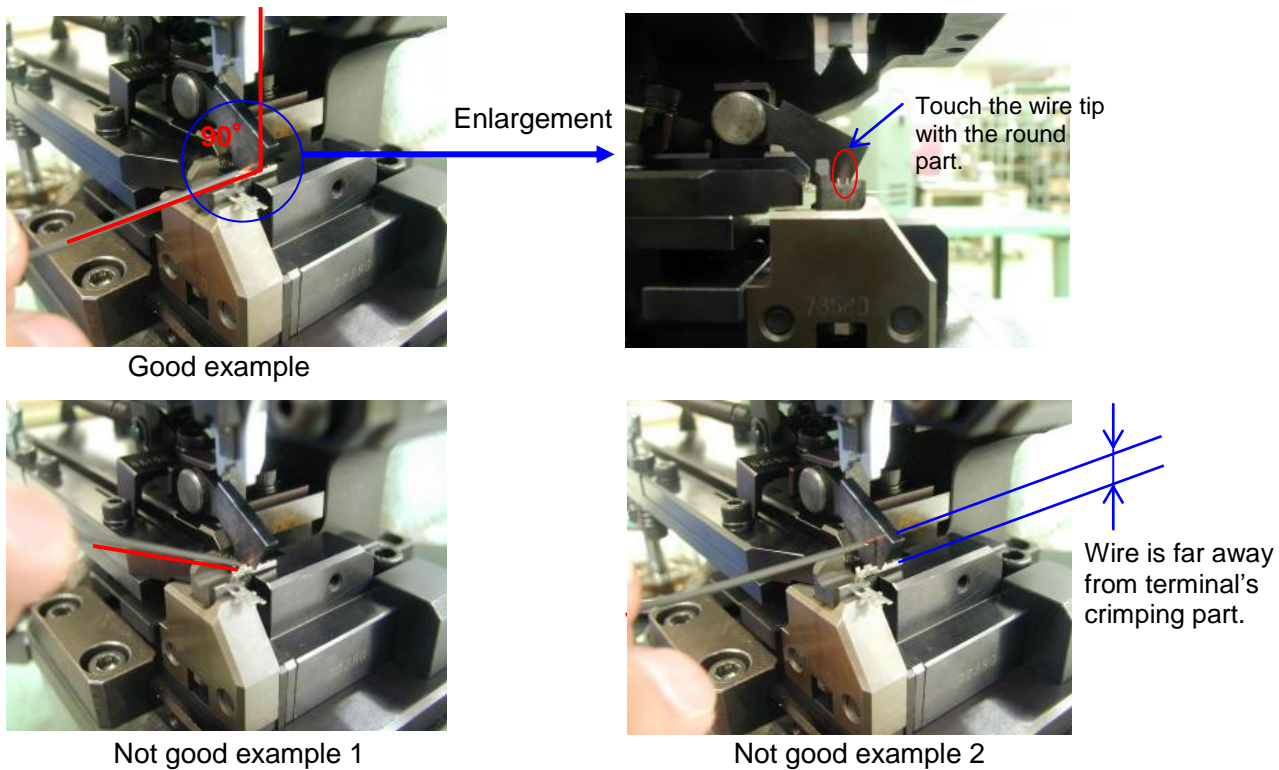

Fig. 5

7-2-2 Checks of crimped part

Check the below points for correct crimping at the beginning, the middle and the end of crimping operation.

① Measurement of crimp height

According to wires to be used, adjust the dials of the applicator at the wire conductor part and the wire insulation part to a proper crimp height. (Fig.6)

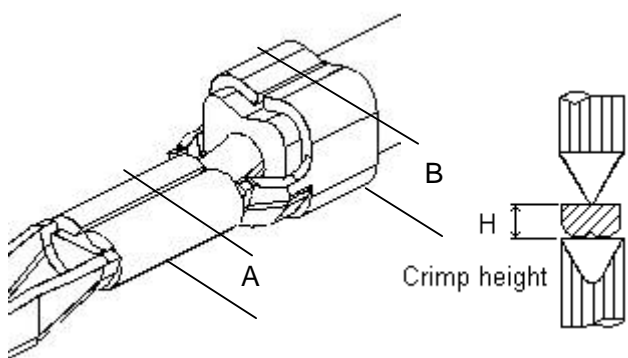

Fig.6

A: The crimp height at the wire barrel should be set to the pre-determined dimensions. Measure the crimp height at the center of the wire barrel using specified micrometer. ("H" shown in Fig. 6)

B: Adjust the crimp height at the wire insulation barrel as per finished outer diameter and kind of wire so that the wire insulation does not come off of the terminal easily and is not crimped excessively.

Table-5: Crimping data

Wire	Crimped part at conductor	Crimped part at insulation
AESSX0.3F	0.95 ± 0.03 mm	1.7 ± 0.05 mm

<b>JST</b>	Title subject: CPT connector	No. CHM-1-2182
------------	------------------------------	----------------

② Crimping condition of wire insulation barrel (Fig 7)

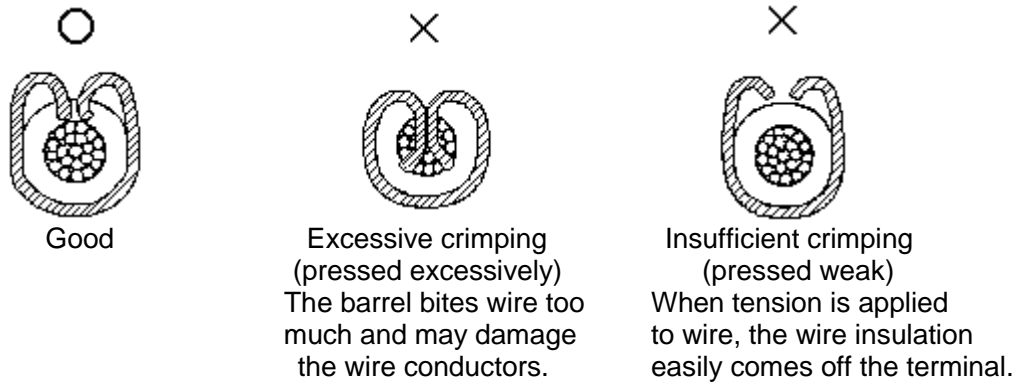

Fig.7

③ Checks of crimping condition at wire insulation barrel (Fig 8)

Cut only the wire insulation barrel, remove the wire insulation and check if wire conductors are not damaged.

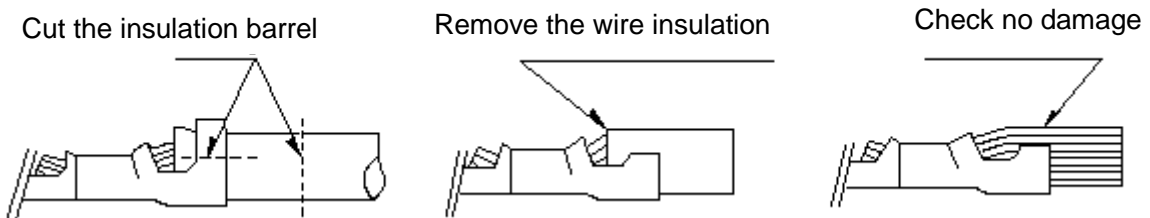

Fig.8

④ Tensile strength at the crimped part

After adjusting the crimp height, check the tensile strength using the trial samples. In case the tensile strength greatly differs from the normal tensile strength (actual value shown in Table 5), check if there is a defect. The tensile strength may be different even in the same wire size due to the difference in wire strength.

<How to evaluate the tensile strength at the crimped part>

Test method: The terminal that crimped a wire of approx. 350 mm shall be fixed and the wire shall be pulled in the axial direction at a constant speed (25 to 100 mm/min.). After the test, the load to break or pull out the wire from the crimped part shall be measured.

Table-6: Tensile strength at the crimped part

Wire size	Requirement	Actual value (Ref. value)
AESSX0.3F	55N	67.9 ~ 69.8 N

⑤ Crimping appearance

Check the crimping appearance visually for correct crimping with equipment such as a magnifier.



Part name of crimped terminal

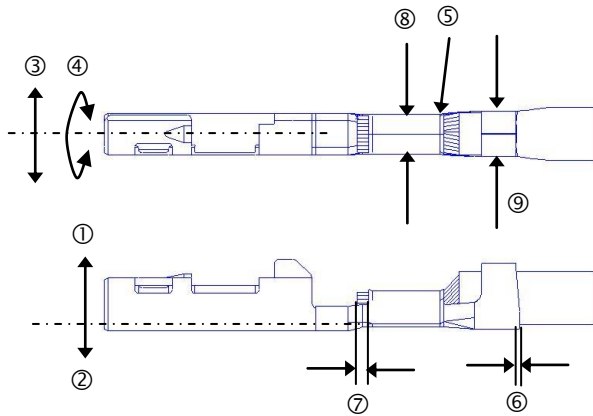
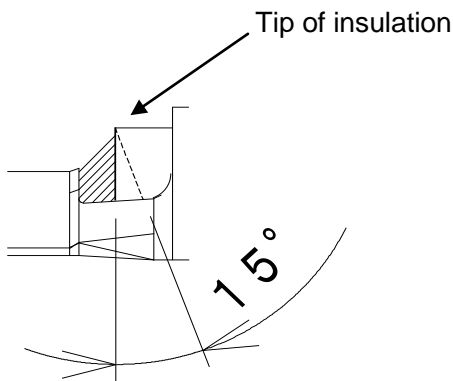

Fig.9

Table-7: Name of crimped terminal

	Item	Control value
①	Bending up	3° max.
②	Bending down	3° max.
③	Twisting	±2° max.
④	Rolling	±6° max.
⑤	Bell-mouth	0.1 ~ 0.3mm
⑥	Cut-off length	0.3 mm max.
⑦	Wire brush length	0.5 mm max.
⑧	Conductor crimp wing	1.1 mm
⑨	Insulation crimp wing	1.4 mm max.

Remarks: There should be no front bell-mouth when crimping is conducted by using JST's applicator.



<Correct crimping condition of insulation>  
The cutting angle at the tip of the insulation should be within 15 degrees.

Fig.10: Appearance of the crimping part of the insulation

<b>JST</b>	Title subject: CPT connector	No. CHM-1-2182
------------	------------------------------	----------------

Examples of defective crimping (Fig 11)

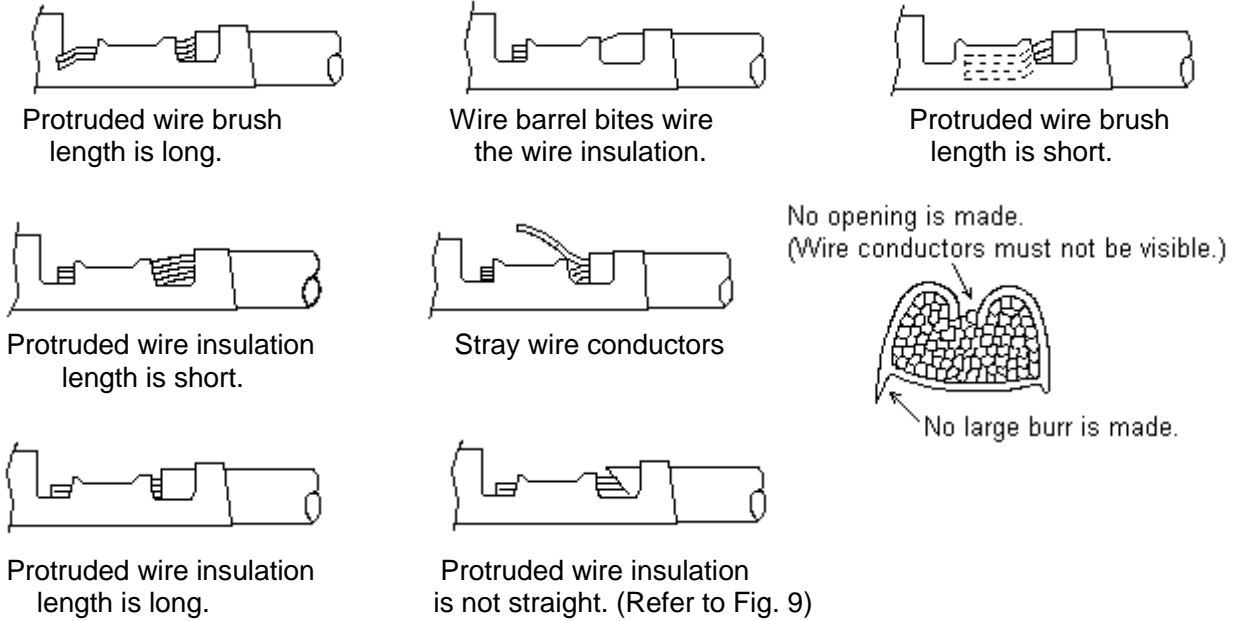

Fig.11

Bending up, bending down, twisting and rolling (Fig 12)

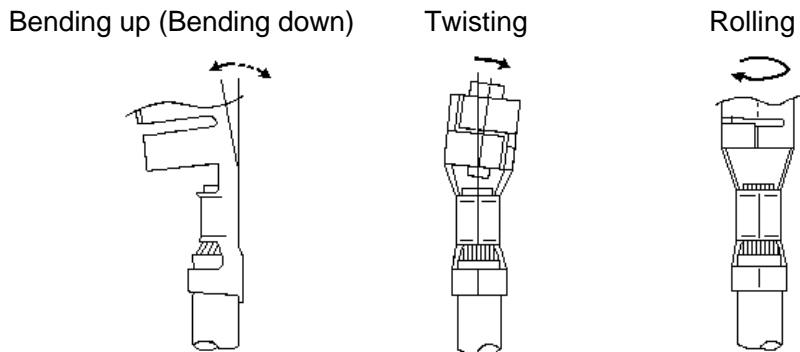

Fig.12

<b>JST</b>	Title subject: CPT connector	No. CHM-1-2182
------------	------------------------------	----------------

⑥ Abrasion of crimping die

Die may crack due to abrasion. In order to prevent from electrical discontinuity from the crack, check the appearance of the terminal's crimping part and replace the die with a new one occasionally.

<Replacement timing of crimping die>

- The size of the burr exceeds the following condition at the appearance of the lower part of the wire conductor's crimped part.

Appearance at the lower part of the wire conductor's crimped part

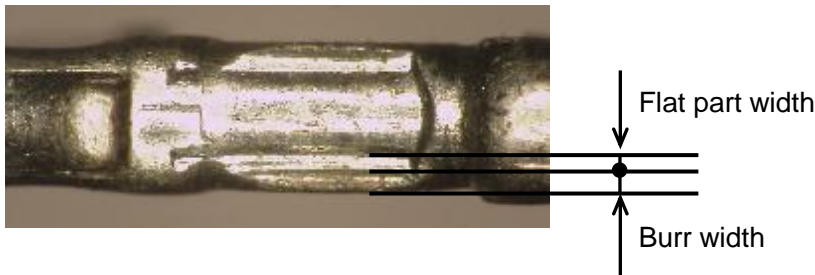

Replacement timing of crimping die:	
$\frac{\text{Burr width}}{\text{Flat part width} + \text{Burr width}}$	$> \frac{1}{3}$

- When the crimped terminal surface becomes rough. (The gloss of the terminal surface disappears.)
- When the seam of the crimped part opens. (See Point A in Figure 13.)

Note: If crimping is conducted beyond the reference timing, a crack may appear on the terminal as shown below.

<Mechanism of occurrence of crack>

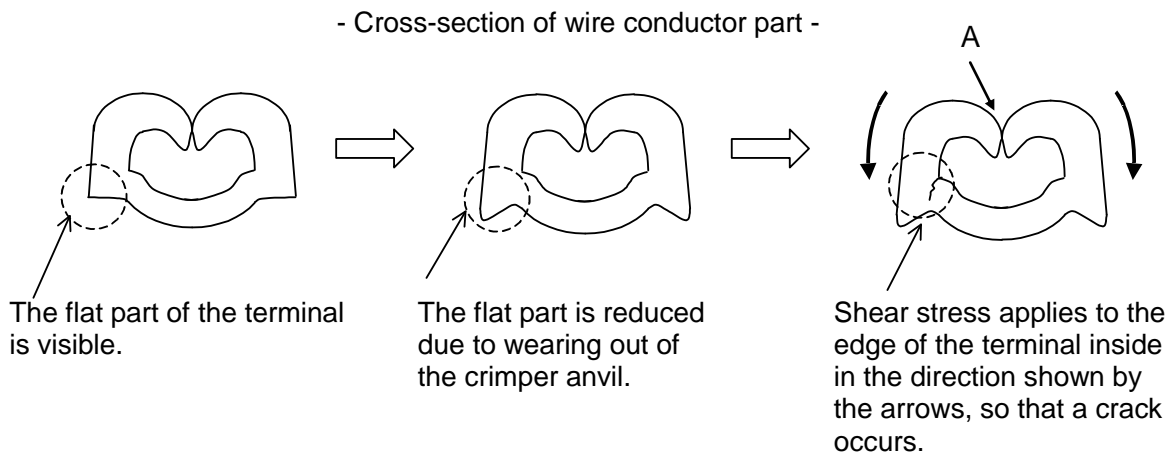

Fig. 13

<b>JST</b>	Title subject: CPT connector	No. CHM-1-2182
------------	------------------------------	----------------

7-3 Precautions for the storage and the handling of the crimped terminal

As the crimped terminal before inserting into the housing is subject to deformation by external forces, pay careful attention to the storage and the handling as below points.

- ① The number of the crimped female terminals for one bundle should be 100 pcs. max.  
Protect the terminals by wrapping with paper, etc. in order to prevent from the deformation and the adhesion of foreign substances. Keep the terminals in an adequate box.
- ② Do not place the terminals in humid area, under direct sunshine and directly on the floor.  
Store them in a clean room with ordinary temperature and humidity.
- ③ Do not overstack the crimped terminals nor place anything on them, since weight of themselves may cause the deformation of the terminal and troubles such as poor contact.
- ④ When the crimped terminal is taken out of bundle, do not pull the wire but hold it near the crimped section and take it out.

8. Harness Assembly Operation

8-1 Inserting the female terminal into the housing

- ① Check that the retainer is in the pre-locking position. (Fig.14)

Note: In the case when the retainer is in the locking position, the female terminal cannot be inserted into the housing. Put it back to the pre-locking position by using a flat approx.2mm-wide precision driver. (Refer to item 8-3)

- ② Check that the direction of the female terminal is proper. (Fig.14)
- ③ Hold the wire part and insert the female terminal in a straight line to engage with the lance securely until audible click is heard. (Fig.15)
- ④ Pull the wire softly to check that the terminal is completely inserted into housing. (Fig.14)

Insert the female terminal into each cavity of the housing according to the above procedures.

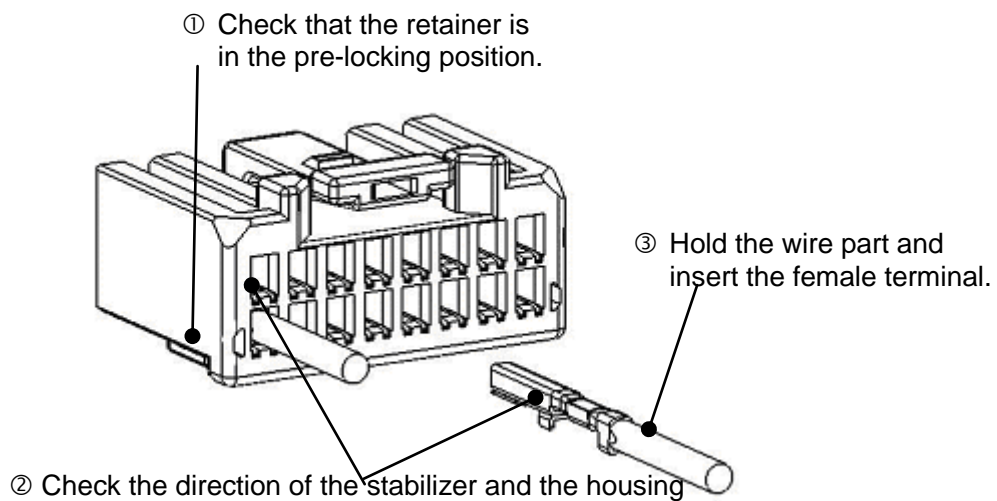

Fig.14: Inserting the female terminal into the housing

<b>JST</b>	Title subject: CPT connector	No. CHM-1-2182
------------	------------------------------	----------------

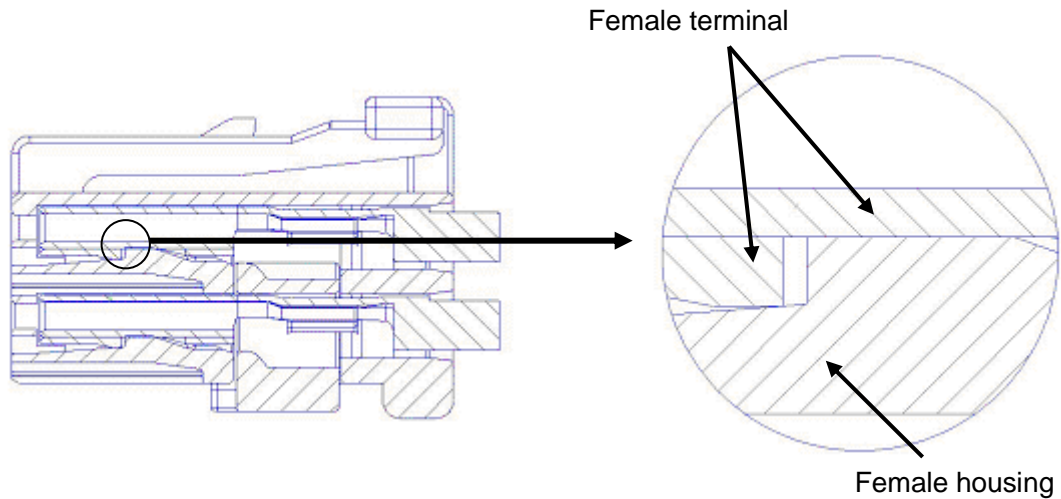

Fig.15: Inserting the female terminal into the housing (cross section)

8-2 Locking the retainer (From the pre-locking position to the locking position)

When the retainer is inserted into the locking position, an audible click should be heard. Push the retainer until the surface A is level with the surface B shown in Figure 16.

Note: Even if only one female terminal is half-inserted, the connector is designed so that the retainer cannot be inserted in the locking position. (It has the mechanism to detect the half-inserted terminal) At this time, make sure again that the female terminal is fully inserted into the housing, and seat the retainer to the locking position.

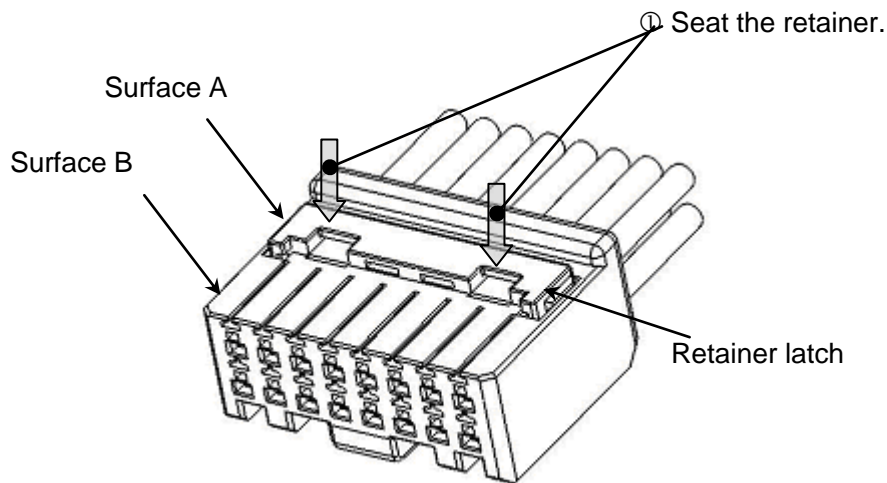

Fig.16: Inserting the retainer into the housing

<b>JST</b>	Title subject: CPT connector	No. CHM-1-2182
------------	------------------------------	----------------

8-3 Releasing the retainer (From the locking position to the pre-locking position)

- ① Use a flat approx. 2 mm-wide precision driver when releasing the retainer from the locking position to the pre-locking position. (Fig.17)
- ② Insert the precision driver into the circled parts as shown in Fig.-16, and raise the retainer due to leverage until an audible click is heard. (Fig.18)

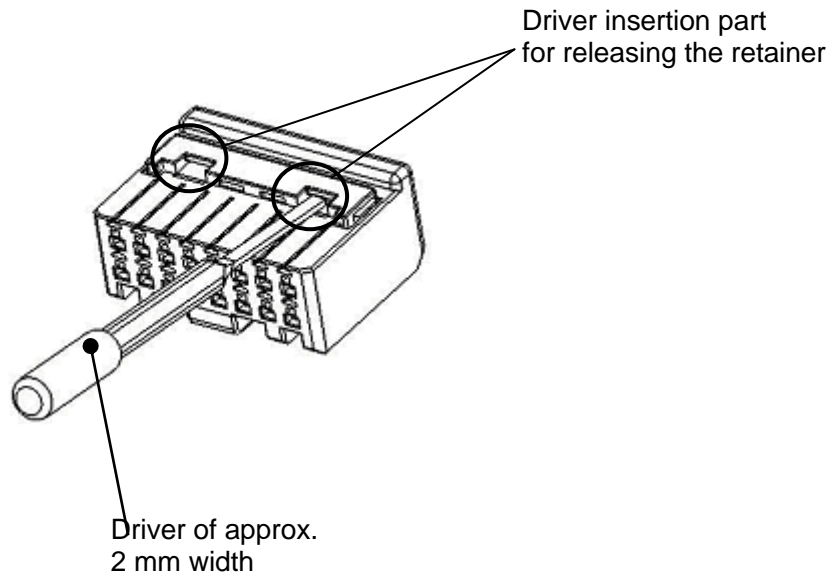

Fig.17

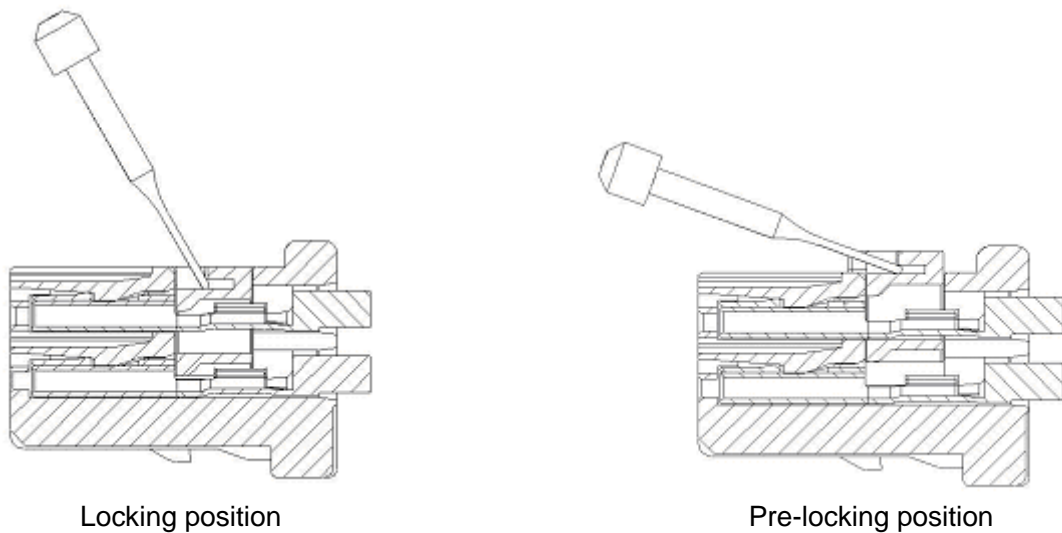

Fig.18

<b>JST</b>	Title subject: CPT connector	No. CHM-1-2182
------------	------------------------------	----------------

8-4 Extracting the female terminal from the housing

- ① Check that the retainer has been released to the pre-locking position.

Note: Unless the retainer is released to the pre-locking position, the female terminal cannot be extracted from the housing.

- ② When releasing the engagement of the housing lance, insert a precision flatblade screwdriver (model No.: EJ-CPT2) into the below of the lance as shown in Fig.19.
- ③ Then, release the engagement between the housing lance and the female terminal in the direction of the arrow, and extract the female terminal from the housing with care. (Fig.19)

Note: Do the operation with care not to scratch and damage the female terminal. Especially, in case of smaller size one than 0.64 terminal, do not deflect unduly housing lance in extracting because the lance may be damaged. Scrap the female assembly which has the cavity that the terminal has been extracted.

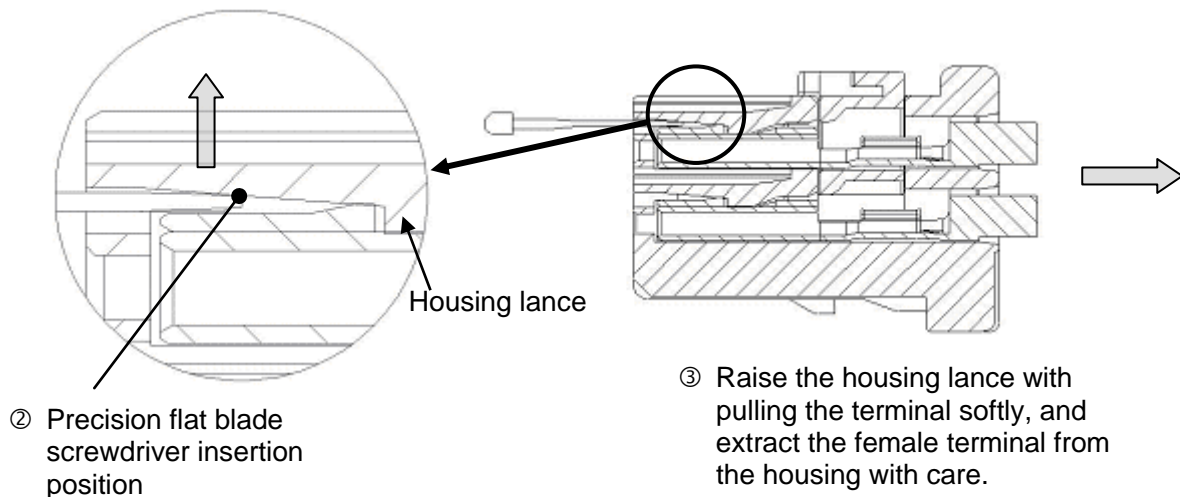

Fig.19

8-5 Electrical continuity check

In electrical continuity inspection, touch the probe on part B as shown in Fig.20.

Do not mate the male terminal with the female terminal in the test, because their terminals can be easily pried, which may result in poor contact.

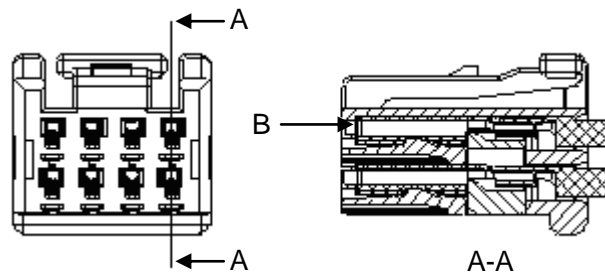

Fig.20: Check points of electrical continuity



<b>JST</b>	Title subject: CPT connector	No. CHM-1-2182
------------	------------------------------	----------------

8-6 In wire handling

Hold the wires in a bundle at the position which is approx. 50mm away from the end face of the female housing.

When it is necessary to bend the wires, make 10mm or more from the end face of the female housing straight before the bending position. (Fig.21)

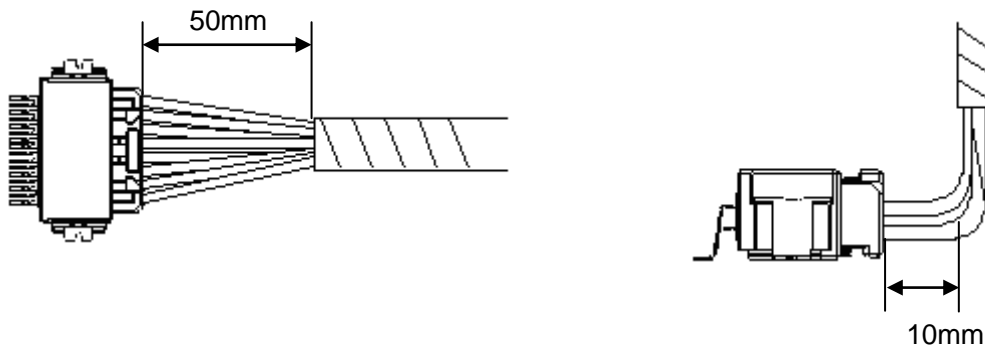

Fig.21: In wire handling

<b>JST</b>	Title subject: CPT connector	No. CHM-1-2182
------------	------------------------------	----------------

9. Mating and Unmating Connector

9-1 Mating the connector

① Be sure to check that the retainer is in the locking position before mating the connector. (Fig.22)

Note: Unless the retainer is in the locking position, the connector cannot be mated due to the mechanism that the half-inserted retainer is detected. Also, in case that the retainer is not in the locking position, the female terminal may be half-inserted.

Be sure to check the insertion condition. (Refer to item 8-1 and 8-2)

- ② Before mating the connector, check that the male pin is not deformed and the connector is free from adhesion of foreign substances.
- ③ The CPT connector's male terminal has a spring, so hold the wires in a bundle and insert the connector with care to the mating axis as parallel as possible (within 5°). (Fig.23)
- ④ Do the mating operation until an audible click is heard. (Fig.24)

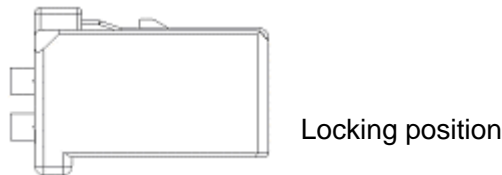

Fig.22

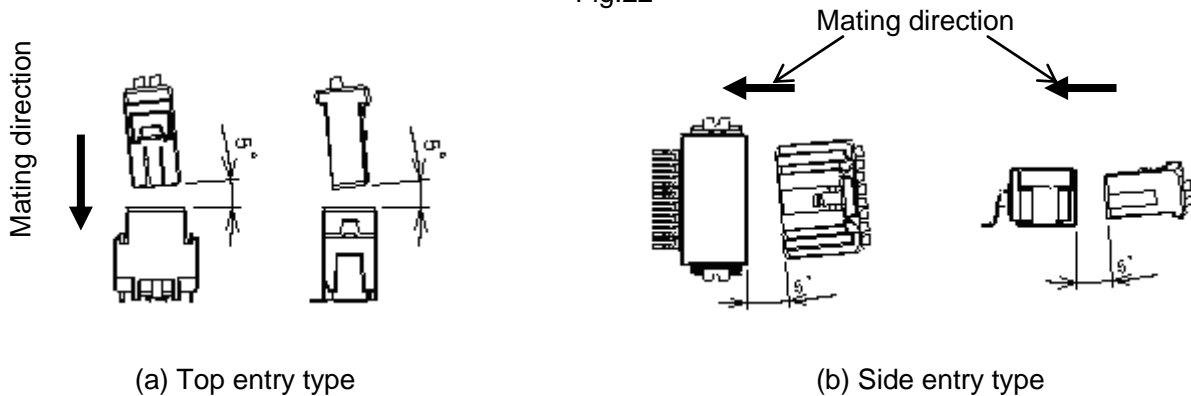
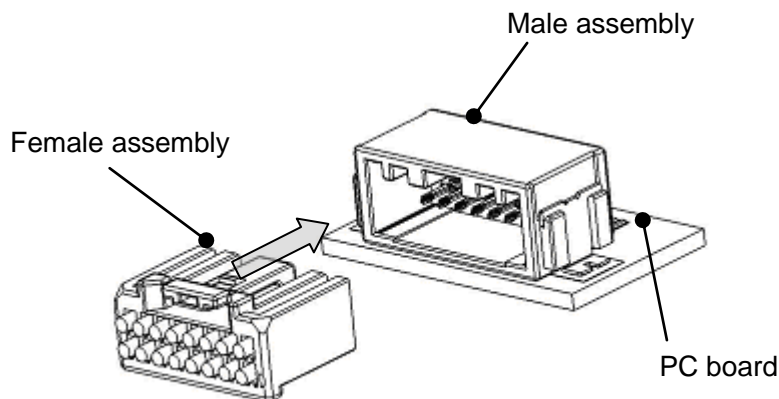

Fig.23: Precautions for mating the connector



③④: Insert the female assembly into the male assembly until an audible click is heard.

Fig.24

<b>JST</b>	Title subject: CPT connector	No. CHM-1-2182
------------	------------------------------	----------------

9-2 Unmating the connector

- ① When unmating the connector, release the housing lock without fail.
- ② Push the lock lever of the female housing with thumb, and the housing lock is released.
- ③ Unmate the female assembly from the male assembly with pushing the lock lever. (Fig.25)

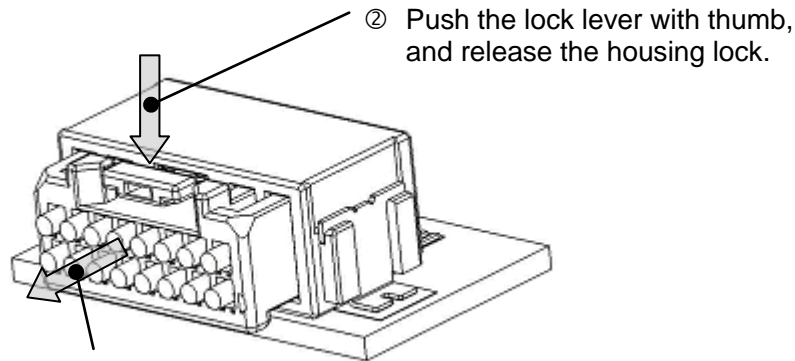

- ③ Unmate the female assembly from the male assembly with pushing the lock lever.

Fig.25

10. Caution for handling carrier tape

When pulling out a carrier tape, if it is handled like the way shown in Photo 1, carrier tape pockets hit each other and soldering leads may be deformed. Please be careful when handling carrier tape.

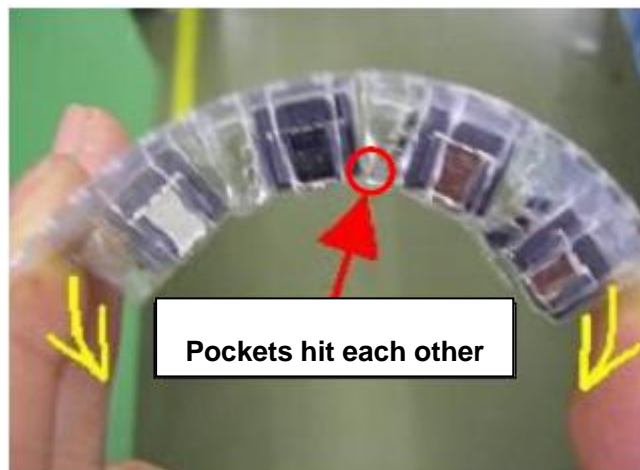

Photo 1

单击下面可查看定价，库存，交付和生命周期等信息

[>>JST\(日本压着端子製造株式会社\)](#)