



**NOTE**

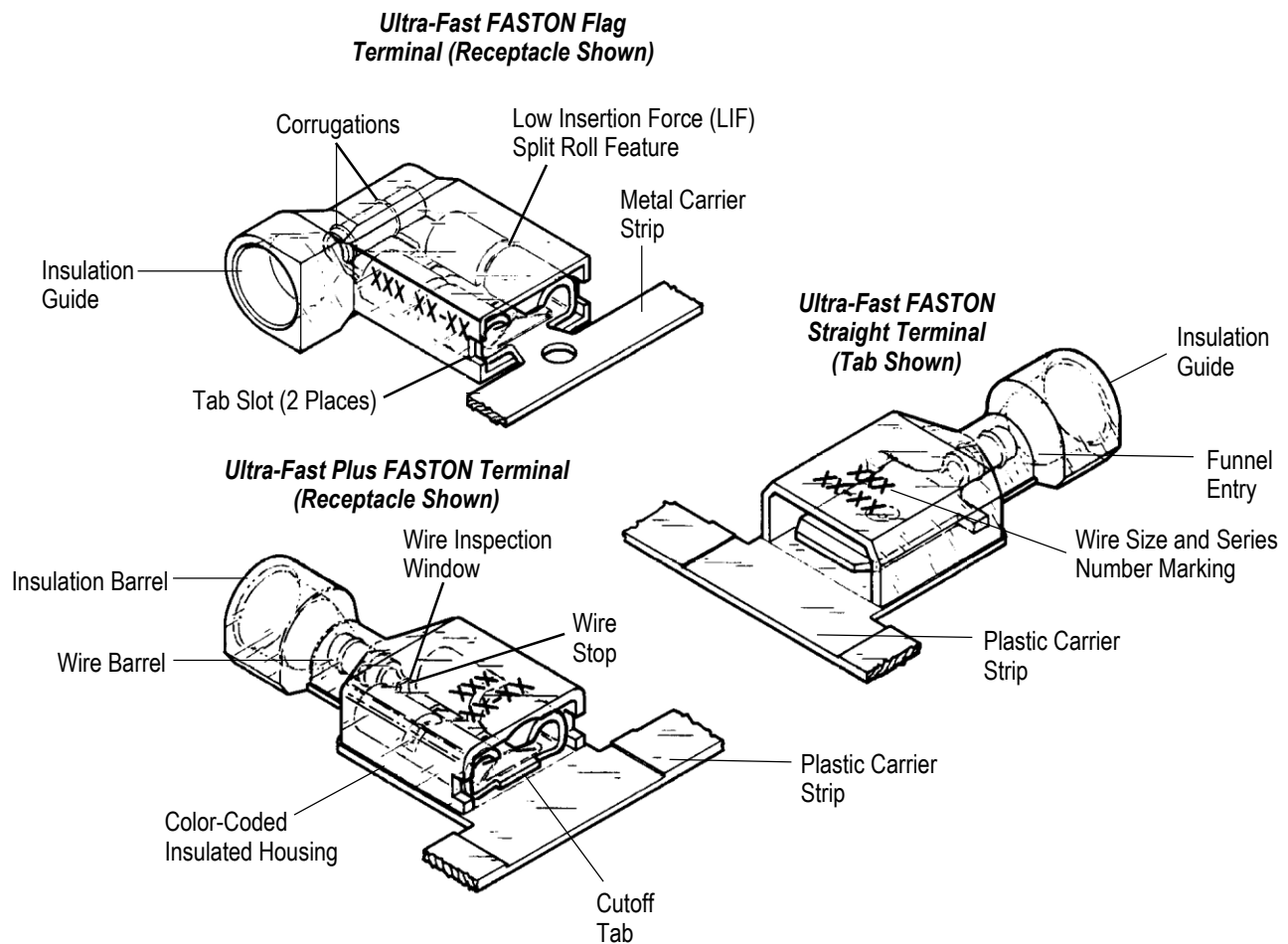
All numerical values are in metric units [with U.S. customary units in brackets]. Dimensions are in millimeters [and inches]. Unless otherwise specified, dimensions have a tolerance of  $\pm 0.13$  [ $\pm .005$ ] and angles have a tolerance of  $\pm 2^\circ$ . Figures and illustrations are for identification only and are not drawn to scale.

**1. INTRODUCTION**

This specification covers the requirements for application of Ultra-Fast, Ultra-Fast Flag, Ultra-Fast Tab, Ultra-Fast Plus, and Ultra-Fast Plus Tab Series 110/125, 187, 205, and 250 Fully-Insulated FASTON Terminals. These terminals are designed for use in 600V applications. The translucent nylon 6/6 insulated housing on the terminals provides protection from short circuits and shock hazard. Ultra-Fast Terminal family products are color coded by wire size. Many of these products are available with either a standard or large insulation diameter (LID) barrel. Each terminal has the series number and wire size molded into the insulation. Internal serrations in the wire barrel permit "F" crimp reliability. Ultra-Fast Plus Terminals feature a co-molded housing produced from two different nylon materials. This insulation barrel is crimpable and provides wire strain relief in extreme wire dress situations or where vibration is present.

The terminals are available in strip form for terminating with semi-automatic or fully-automatic powered machines, and in loose-piece for terminating with manual hand-held tools.

When corresponding with TE Connectivity Personnel, use the terminology provided in this specification to facilitate your inquiries for information. Basic terms and features of this product are provided in Figure 1.



**Figure 1**

## 2. REFERENCE MATERIAL

### 2.1. Revision Summary

- ◆ Added new text to Paragraph 5.4.
- ◆ Updated format to TE corporate standards

### 2.2. Customer Assistance

Reference Product Base Part Number 520261 and Product Code 1117 are representative of Ultra-Fast Fully-Insulated FASTON Terminals. Use of these numbers will identify the product line and help you to obtain product and tooling information when visiting [www.te.com](http://www.te.com) or calling the number at the bottom of page 1.

### 2.3. Drawings

Customer drawings for product part numbers are available from [www.te.com](http://www.te.com). Information contained in the customer drawing takes priority.

### 2.4. Specifications

The following Product Specification provide product performance and test results.

- [108-2017](#) Ultra-Fast Tabs
- [108-2043](#) Ultra-Fast Receptacles and Ultra-Fast Flag Receptacles
- [108-2044](#) Ultra-Fast Plus Receptacles

### 2.5. Instructional Material

Instruction sheets (408-series) provide product assembly instructions or tooling setup and operation procedures and customer manuals (409-series) provide machine setup and operating procedures. Instructional material that pertain to this product are:

- [408-2095](#) Hand Crimping Tools 69710-1
- [408-3295](#) Preparing Reel of Contacts for Applicator Tooling
- [408-4105](#) Straight Action Crimper 217200-1
- [408-4153](#) Crimping Die Assemblies 224027-1 and -2
- [408-6976](#) Hand Crimping Tool Frame 58078-3
- [408-8051](#) Miniature Quick-Change Applicators (Side-Feed Type)
- [408-8053](#) Conversion Guide for Miniature Quick-Change Applicators
- [408-8058](#) Miniature Quick-Change Applicators (End-Feed Type)
- [408-8079](#) Miniature Quick-Change Applicators (Side-Feed Type with Insulation Crimper)
- [408-9225](#) Crimping Die Assemblies 58269-2 through 58269-5
- [408-9227](#) Crimping Die Assemblies 58268-1 and 58268-2
- [408-9277](#) Crimping Die Assembly 58052-3
- [408-9278](#) Crimping Die Assemblies 58079-3 and 58080-3
- [408-9279](#) Crimping Die Assemblies 90390-3 and 90391-3
- [408-9296](#) Crimping Die Assemblies 58308-1 and 58308-2
- [408-9816](#) Handling of Reeled Products
- [408-9902](#) Applicator Tooling Matrix (for Applicators 466778-4, 766779-4, 567041-2, 567082-2, 567117-2, and 567142-2)
- [409-5128](#) AMP-O-LECTRIC\* Model "K" Terminating Machine 565435-5
- [409-5842](#) AMP-O-LECTRIC Model "G" Terminating Machine 354500-1
- [409-5862](#) 626 Pneumatic Tooling Assemblies 189721-1 and 189722-1
- [409-5878](#) AMPOMATOR\*CLS IV+ Lead-Making Machine 356500-[ ]

### 3. REQUIREMENTS

#### 3.1. Safety

Do not stack product shipping containers so high that the containers buckle or deform.

#### 3.2. Storage

##### A. Ultraviolet Light

Prolonged exposure to ultraviolet light may deteriorate the chemical composition used in the product material.

##### B. Reel Storage

When using reeled terminals, store coil wound reels horizontally and traverse wound reels vertically.

##### C. Shelf Life

The product should remain in the shipping containers until ready for use to prevent deformation to components. The product should be used on a first in, first out basis to avoid storage contamination that could adversely affect performance.

##### D. Chemical Exposure

Do not store product near any chemical listed below as they may cause stress corrosion cracking in the material.

Alkalies	Ammonia	Citrates	Phosphates	Citrates	Sulfur Compounds
Amines	Carbonates	Nitrites	Sulfur Nitrites		Tartrates



**NOTE**

Where the above environmental conditions exist, phosphor-bronze terminals are recommended instead of brass.



**CAUTION**

Exposure to alcohol will break down the insulation barrel of Ultra-Fast Plus terminals

#### 3.3. Terminal Selection

These terminals are easily matched to the correct wire size by their color-coded insulated housings. Terminal color and corresponding wire range are listed in Figure 2.



**NOTE**

Terminals are also designated by tab thickness and tab width (series number). Each product grouping offers a particular assortment of choices. Contact your local TE Representative for current available choices.

TERMINAL COLOR	TERMINAL WIRE RANGE
Violet	26 AWG – 22 AWG
Red	22 AWG – 18 AWG
Blue	16 AWG – 14 AWG
Yellow	12 AWG – 10 AWG

Figure 2

#### 3.4. Wire Selection

The terminals will accept solid, fused, and stranded wire (except flag terminals which accept stranded wire only) sizes and insulation diameter shown in Figure 3.

TERMINAL TYPE	TERMINAL WIRE RANGE	WIRE INSULATION DIAMETER
Ultra-Fast	26 AWG – 10 AWG	8.13 [.320] Max
Ultra-Fast Flag	22 AWG – 14 AWG	6.60 [.260] Max
Ultra-Fast Plus	22 AWG – 14 AWG	1.52 – 4.06 [.060 – .160]

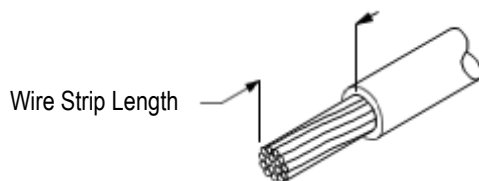
Figure 3

### 3.5. Wire Preparation

Strip the wire to the dimensions given in Figure 4.


**CAUTION**

Do not nick, cut, or scrape the wire conductor during the stripping operation.



Note: Not to Scale

TERMINAL SERIES	WIRE SIZE RANGE	WIRE STRIP LENGTH ( $\pm 0.41$ [ $\pm 0.016$ ])	
		ONE WIRE	TWO WIRES
110/125	26 AWG – 14 AWG	7.14 [.281]	7.92 [.312]
187	22 AWG – 14 AWG	7.14 [.281]	7.92 [.312]
187 Flag Terminals LID (Large Insulation Diameter Wire)	16 AWG – 14 AWG	7.92 [.312]	8.51 [.335]
205	22 AWG – 18 AWG	7.14 [.281]	7.92 [.312]
205 Flag Terminals	22 AWG – 18 AWG	7.92 [.312]	8.51 [.335]
250	22 AWG – 14 AWG	7.14 [.281]	7.92 [.312]
	12 AWG – 10 AWG	7.92 [.312]	9.52 [.375]
250 Flag Terminals	22 AWG – 14 AWG	7.92 [.312]	8.51 [.335]

Figure 4

### 3.6. Crimp Requirements

The terminal must be crimped in the appropriate tooling according to the instructions packaged with the tooling.


**CAUTION**

Terminal insulation shall NOT be cut or broken during the crimping operation. Reasonable care should be taken by tooling operators to provide undamaged terminations.

#### A. Dielectric Withstanding Voltage Test

During initial tooling setup or after any tooling change or replacement, five sample terminals shall be tested for dielectric withstanding voltage as follows:

Prepare samples by applying them to wire in accordance with the crimp requirements. Seal the mating end of the terminal with dielectric wax or other suitable material to prevent entrance of the lead shot. Embed the samples in lead shot no. 12 (1.27 [.050] in diameter). Apply a test potential of 3400 VAC to the wire at a rate of 500 V per second for one minute, with the lead shot acting as the other electrode.

The samples shall show no electrical breakdown or flash-over as a result of this testing procedure.

## B. Crimp Height

Because these terminals are fully insulated, crimp height readings cannot be measured over the insulation. Proper crimp height must be measured using a slug of solid-core solder with a ratio of 60% tin to 40% lead, 50/50 or tin "Lead-Free" version solder is acceptable. Solder diameter according to wire size is listed in Figure 5.

WIRE SIZE RANGE	SOLDER DIAMETER
26 AWG – 18 AWG	3.18 [.125]
22 AWG – 18 AWG (Flag Terminals)	4.75 [.187]
16 AWG – 14 AWG	4.75 [.187]
12 AWG – 10 AWG	6.35 [.250]

Figure 5

The height of the crimped solder must meet the dimensions given in Figure 6.



### NOTE

Solder slug crimp heights are for applicators used in AMP-O-LECTRIC terminating machine and AMPOMATOR lead-making machine. Check instruction sheets (408-series) for crimp heights for die assemblies used in AUTO-PRO machine and hand tools. DO NOT measure terminal wire barrel to obtain crimp height. Follow these requirements for measuring crimp height. Refer to Figure 6 (solder slug crimp height).



### CAUTION

Crimp height dimensions must not be applied directly to terminal. This practice will over-crimp the terminal, cracking the wire barrel, and possibly cause damage to tooling.

## C. Cutoff Tab and Burr

Cutoff tabs are the remaining portion of the carrier strip after the terminal is cut from the strip. The cutoff tab and burr must be visible as shown in Figure 6.

## D. Effective Crimp Length

Effective crimp length is defined as that portion of the wire barrel, excluding bellmouths, fully formed by the crimping tool. For optimum crimp effectiveness, the crimp must be within the area shown and must meet the crimp requirements provided in Figure 6.

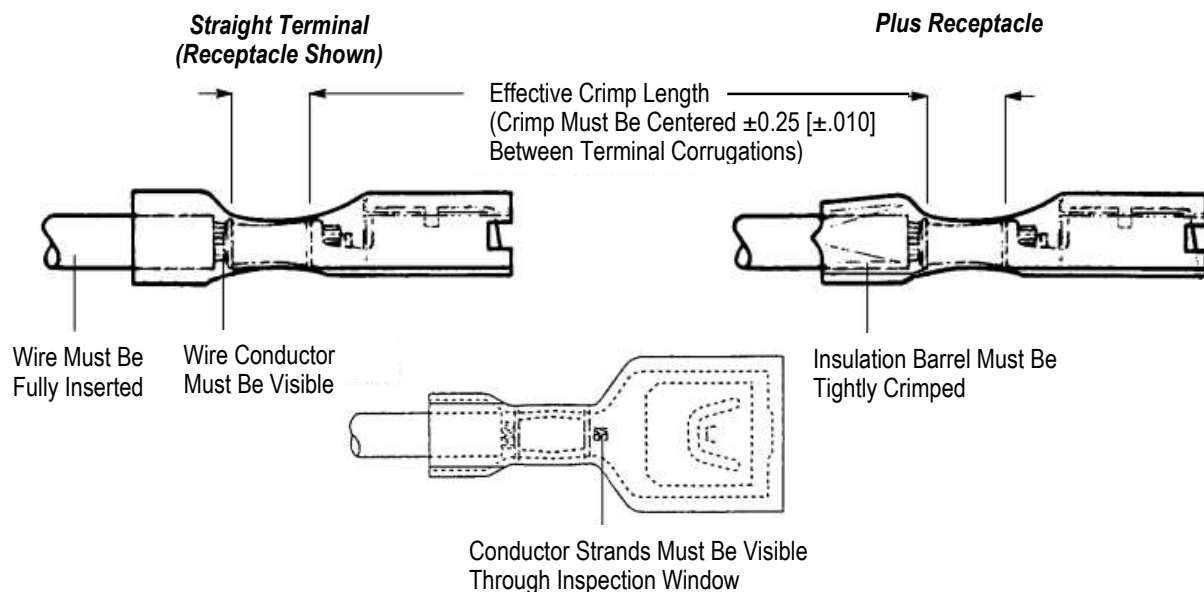
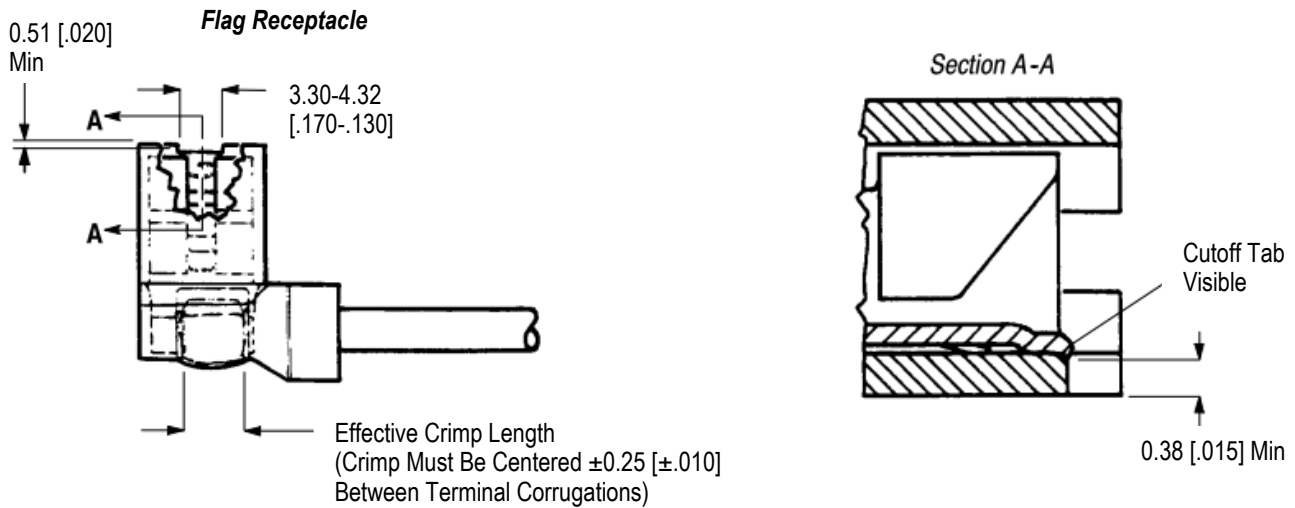


Figure 6 (continued)


**SERIES 110/125 STRAIGHT RECEPTACLES**

TERMINAL WIRE RANGE (AWG)	TERMINAL INSULATION BARREL		WIRE		SOLDER SLUG CRIMP HEIGHT ■ ±0.05 [±.002]	TENSILE STRENGTH (Min) N [lb]
	TYPE	DIAMETER	QUANTITY	SIZE (AWG)		
26 – 22	Standard	2.54 [.100] Max	1	26	1.52 [.060]	17.8 [4]
				24	1.52 [.060]	26.7 [6]
				22	1.65 [.065]	44.5 [10]
22 – 18	Standard	3.05 [.120] Max	1	22	1.65 [.065]	44.5 [10]
				20	1.65 [.065]	71.2 [16]
				18	1.78 [.070]	89.0 [20]
	Large	5.84 [.230] Max	1	22	1.65 [.065]	44.5 [10]
				20	1.65 [.065]	71.2 [16]
				18	1.78 [.070]	89.0 [20]
16 – 14	Large	6.60 [.260] Max	1	22	1.78 [.070]	44.5 [10]
				20	1.78 [.070]	71.2 [16]
			2	16	1.78 [.070]	133.4 [30]
				14	1.90 [.075]	266.9 [60]
			2	18	1.78 [.070]	89.0 [20]

**Figure 6 (continued)**

■ Refer to NOTE in Paragraph 3.6, B, Crimp Height

## SERIES 187, 205, AND 250 STRAIGHT RECEPTACLES AND TABS

TERMINAL WIRE RANGE (AWG)	TERMINAL INSULATION BARREL		WIRE		SOLDER SLUG CRIMP HEIGHT ±0.05 [±.002]	TENSILE STRENGTH (Min) N [lb]
	TYPE	DIAMETER	QUANTITY	SIZE (AWG)		
22 – 18	Standard	3.43 [.135] Max	1	22	1.65 [.065]	44.5 [10]
				20	1.65 [.065]	71.2 [16]
			2	18	1.78 [.070]	89.0 [20]
				22	1.78 [.070]	44.5 [10]
	Large	5.84 [.230] Max	1	20	1.78 [.070]	71.2 [16]
				18	1.78 [.070]	89.0 [20]
			2	22	1.78 [.070]	44.5 [10]
				20	1.78 [.070]	71.2 [16]
16 – 14	Standard	4.06 [.160] Max	1	16	1.78 [.070]	133.4 [30]
				14	1.90 [.075]	266.9 [60]
			2	18	1.78 [.070]	89.0 [20]
	Large	6.60 [.260] Max	1	16	1.78 [.070]	133.4 [30]
				14	1.90 [.075]	266.9 [60]
			2	18	1.78 [.070]	89.0 [20]
12 – 10●	Large	8.13 [.320] Max	1	12	2.41 [.095]	311.4 [70]
				10	2.54 [.100]	355.9 [80]
			2	16	2.41 [.095]	133.4 [30]
				14	2.41 [.095]	266.9 [60]

## SERIES 187, 205, AND 250 FLAG RECEPTACLES

TERMINAL WIRE RANGE (AWG)	TERMINAL INSULATION BARREL		WIRE		SOLDER SLUG CRIMP HEIGHT ±0.05 [±.002]	TENSILE STRENGTH (Min) N [lb]
	TYPE	DIAMETER	QUANTITY	SIZE (AWG)		
22 – 18	Standard	4.19 [.165] Max	1	22	1.65 [.065]	44.5 [10]
				20	1.65 [.065]	71.2 [16]
			2	18	1.78 [.070]	89.0 [20]
				22	1.78 [.070]	44.5 [10]
	Large	5.84 [.230] Max	1	20	1.78 [.070]	71.2 [16]
				18	1.78 [.070]	89.0 [20]
			2	22	1.78 [.070]	44.5 [10]
				20	1.78 [.070]	71.2 [16]
16 – 14	Standard	4.70 [.185] Max	1	16	1.78 [.070]	133.4 [30]
				14	1.90 [.075]	266.9 [60]
			2	18	1.78 [.070]	89.0 [20]
	Large	6.60 [.260] Max	1	16	1.78 [.070]	133.4 [30]
				14	1.90 [.075]	266.9 [60]
			2	18	1.78 [.070]	89.0 [20]

●Series 250 (12 – 10) terminals are available with large diameter insulation barrel only.

Figure 6 (continued)

■ Refer to NOTE in Paragraph 3.6, B, Crimp Height



**SERIES 110/125 PLUS RECEPTACLES**

TERMINAL WIRE RANGE (AWG)	TERMINAL INSULATION BARREL		WIRE		SOLDER SLUG CRIMP HEIGHT $\pm 0.05$ [ $\pm .002$ ]	TENSILE STRENGTH (Min) N [lb]
	TYPE	DIAMETER	QUANTITY	SIZE (AWG)		
22 – 18	Standard	1.52-3.05 [.060-.120]	1	22	1.65 [.065]	44.5 [10]
				20	1.65 [.065]	71.2 [16]
				18	1.78 [.070]	89.0 [20]
		0.76-1.52 [.030-.060]	2	22	1.78 [.070]	44.5 [10]

**SERIES 187 AND 250 PLUS RECEPTACLES AND SERIES 250 PLUS TABS**

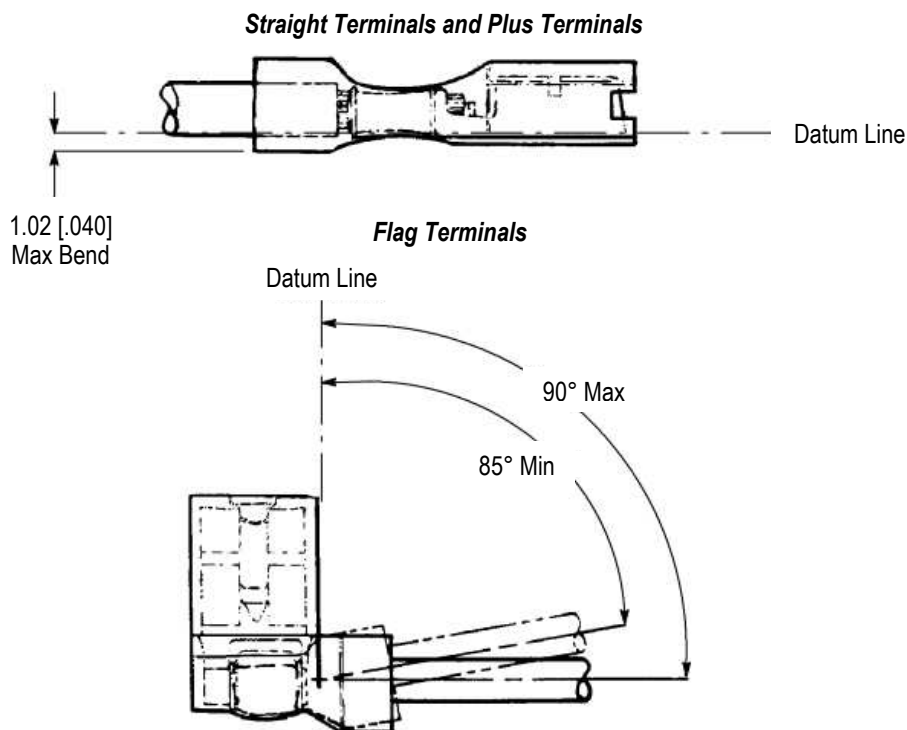
TERMINAL WIRE RANGE (AWG)	TERMINAL INSULATION BARREL		WIRE		SOLDER SLUG CRIMP HEIGHT $\pm 0.05$ [ $\pm .002$ ]	TENSILE STRENGTH (Min) N [lb]
	TYPE	DIAMETER	QUANTITY	SIZE (AWG)		
22 – 18	Standard	1.52-3.43 [.060-.135]	1	22	1.65 [.065]	44.5 [10]
				20	1.65 [.065]	71.2 [16]
				18	1.78 [.070]	89.0 [20]
		0.76-1.70 [.030-.067]	2	22	1.78 [.070]	44.5 [10]
16 – 14	Standard	2.29-4.06 [.090-.160]	1	16	1.90 [.075]	133.4 [30]
				14	2.03 [.080]	266.9 [60]
		1.14-2.03 [.045-.080]	2	18	1.90 [.075]	89.0 [20]

**Figure 6 (end)**

■ Refer to NOTE in Paragraph 3.6, B, Crimp Height

**E. Straightness**

The force applied during crimping may cause some bending between the wire barrel and the mating portion of the terminal. Such deformation is acceptable within the following limits. The crimped portion, including cutoff tab and burr, must not be bent beyond the limits shown in Figure 7.


**Figure 7**



## F. Twist and Roll

There should be no twist or roll of the wire barrel or mating portion of the crimped terminal that would cause overstress or impair usage.

### 3.7. Mating Overcycle

The rolled shape of the receptacles determines the contact mating force. This design is NOT intended for a high number of mating cycles over the life of the product. Therefore, the maximum number of mating cycles (matings/un-matings) recommended is 10.

The forces required to mate and unmate a test mating tab and receptacle are specified in the Product Specifications (108-series) listed in Paragraph 2.4. The force must be measured using a testing device capable of holding the reading. It must also provide accurate alignment with slow and steady mating and unmating of the test tab and receptacle.

### 3.8. Mating Tab Dimensions

Features and dimensional requirements for tab terminals intended for mating with these receptacles is listed in Figure 8.

**i NOTE** Test tabs shall have dimensions as shown in Figure 8, except Dimension "C" shall have a tolerance of  $\pm 0.008$  [ $\pm 0.0003$ ] for brass tabs and  $\pm 0.013$  [ $\pm 0.0005$ ] for steel, and raised plateaus around the detents shall be limited to a total of  $0.03$  [ $0.001$ ] for both sides.

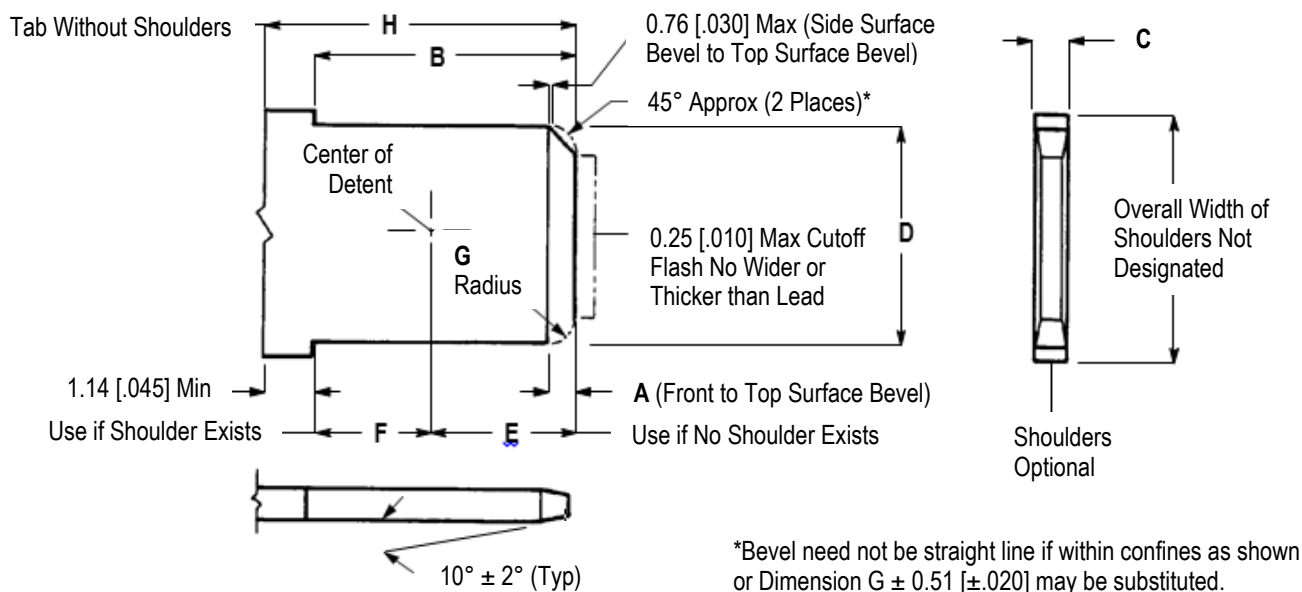


Figure 8 (continued)

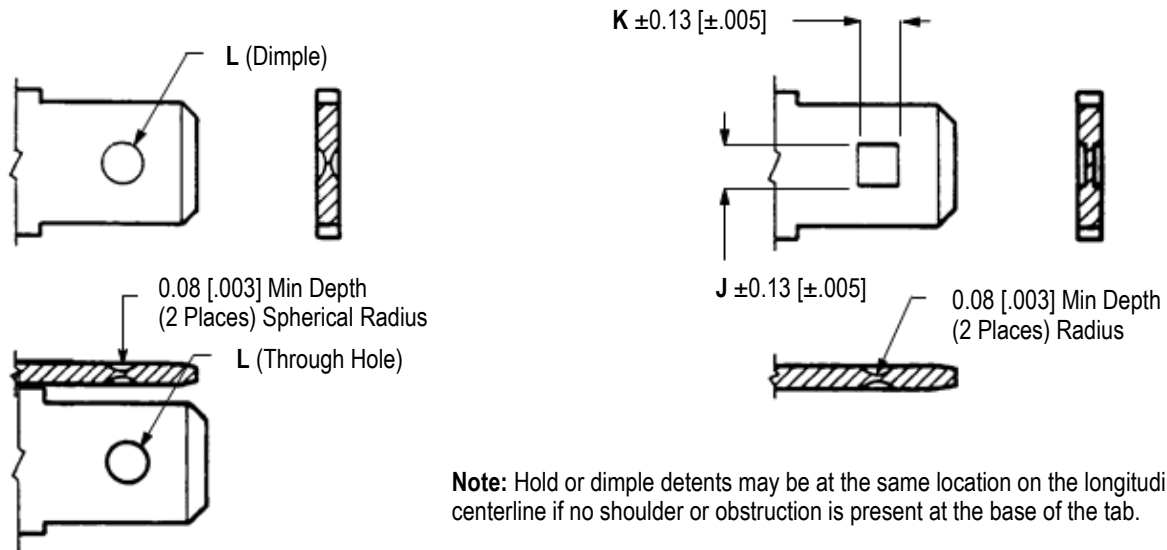
TAB SIZE (Nominal)	DIMENSION							
	A +0.13 [+.005]	B (Min)	C +0.03 [+.001]	D +0.08 [+.003]	E +0.20 [+.008]	F +0.08 [+.003]	G +0.51 [+.020]	H (Min)
6.35 X 0.81 [.250 X .032] With Dimple	0.89 [.035]	7.80 [.307]	0.81 [.032]	6.35 [.250]	3.86 [.152]	4.06 [.160]	1.27 [.050]	8.94 [.352]
6.35 X 0.81 [.250 X .032] With Hole	0.89 [.035]	7.80 [.307]	0.81 [.032]	6.35 [.250]	4.52 [.178]	3.40 [.134]	1.27 [.050]	8.94 [.352]
5.21 X 0.81 [.205 X .032] With Dimple	0.89 [.035]	6.20 [.244]	0.81 [.032]	5.20 [.205]	2.54 [.100]	3.81 [.150]	1.27 [.050]	7.29 [.287]
5.21 X 0.81 [.205 X .032] With Hole	0.89 [.035]	6.20 [.244]	0.81 [.032]	5.20 [.205]	3.18 [.125]	3.18 [.125]	1.27 [.050]	7.29 [.287]
4.75 X 0.81 [.187 X .032] With Dimple	0.89 [.035]	6.22 [.245]	0.81 [.032]	4.75 [.187]	2.54 [.100]	3.81 [.150]	1.27 [.050]	7.37 [.290]
4.75 X 0.81 [.187 X .032] With Hole	0.89 [.035]	6.22 [.245]	0.81 [.032]	4.75 [.187]	3.18 [.125]	3.18 [.125]	1.27 [.050]	7.37 [.290]
4.75 X 0.51 [.187 X .020] With Dimple	0.76 [.030]	6.22 [.245]	0.51 [.020]	4.75 [.187]	2.54 [.100]	3.81 [.150]	1.14 [.045]	7.37 [.290]
4.75 X 0.51 [.187 X .020] With Hole	0.76 [.030]	6.22 [.245]	0.51 [.020]	4.75 [.187]	3.18 [.125]	3.18 [.125]	1.14 [.045]	7.37 [.290]
3.18 X 0.81 [.125 X .032] With Dimple or Hole	0.51 [.020]	6.98 [.275]	0.51 [.020]	3.18 [.125]	1.57 [.062]	5.54 [.218]	0.89 [.035]	8.13 [.320]
3.18 X 0.51 [.125 X .020] With Dimple or Hole	0.51 [.020]	6.98 [.275]	0.51 [.020]	3.18 [.125]	1.57 [.062]	5.54 [.218]	0.89 [.035]	8.13 [.320]
2.79 X 0.81 [.110 X .032] With Dimple or Hole	0.51 [.020]	6.98 [.275]	0.81 [.032]	2.79 [.110]	1.57 [.062]	5.54 [.218]	0.89 [.035]	8.13 [.320]
2.79 X 0.51 [.110 X .020] With Dimple or Hole	0.51 [.020]	6.98 [.275]	0.51 [.020]	2.79 [.110]	1.57 [.062]	5.54 [.218]	0.89 [.035]	8.13 [.320]


**NOTES**

1. For tab detent dimensions, see Paragraph 3.9.
2. Top and bottom tab surfaces shall be within .1% and free from burrs greater than 10% of tab thickness or raised plateaus, except as noted in Paragraph 3.8.
3. Dimensional measurements shall not include plating, burrs, or flatness tolerance.

**Figure 8 (end)**
**3.9. Tab Detent Configurations**

A tab having no locking feature may be used for applications where low mating retention forces are desirable. Where higher forces are sought, a tab with a detent meeting the requirements shown should be used. Hole detents provide the greatest retention forces, while dimples provide acceptable medium- range forces. Refer to Figure 9.



**Note:** Hold or dimple detents may be at the same location on the longitudinal centerline if no shoulder or obstruction is present at the base of the tab.

TAB WIDTH (Nominal)	DIMPLE DETENT DIMENSION $\pm 0.13$ [.005]		DIMPLE OR THROUGH HOLE DETENT DIAMETER
	J	K	L
6.35 [.250]	2.36 [.093]	1.90 [.075]	$1.78 +0.25/-0.13$ [.070 +.010/-0.005]
5.20 [.205]	2.36 [.093]	1.90 [.075]	$1.75 \pm 0.15$ [.069 $\pm$ .006]
4.75 [.187]	1.57 [.062]	1.37 [.054]	$1.40 \pm 0.13$ [.055 $\pm$ .005]
2.79 [.110]	1.57 [.062]	1.22 [.048]	$1.22 \pm 0.08$ [.048 $\pm$ .003]

**Figure 9**

#### 4. QUALIFICATION



**NOTE**

Because of the many variations of qualifications and performance capabilities within this product line, contact the Product Information Center at the number listed at the bottom of page 1 for specific requirements.

Ultra-Fast Fully-Insulated FASTON Terminals are supported by the following commercial, military, and government qualification and specification organizations.

##### 4.1. Underwriters Laboratories Inc. (UL) and CSA International

These terminals meet Specification UL-310 for quick-connect terminals and are listed by UL in File E66717. These terminals meet CSA C22.2 Specification 153 for quick-connect terminals and are certified to CSA International in File LR 7189.



**NOTE**

UL does not qualify this type of terminal when designed for application to wire size 24 AWG or smaller, 0.41 [.016]-thick tabs, or wire size 14 AWG applied to Series 110/125 terminals.

##### 4.2. Verband der Elektrotechnik (VDE)

These terminals are VDE tested according to DIN VDE 0627/9.91, VDE-Reg. 5193.

### 4.3. TUV Rheinland

Ultra-Fast Plus Terminals have been tested by TUV Rheinland of North America, Inc., TUV File E9071003 and has been found suitable for end product certification to:

EN 60 950/09.87

DIN IEC 601- 1 Part 1/VDE 0750 T1/05.82

DIN IEC 380/VDE 0806/08.81

DIN VDE 0700 t1/02.81

## 5. TOOLING

Tooling that accommodates the full wire size range are designed for terminating these terminals. Tooling part numbers and instructional material packaged with the tooling are shown in Figure 11.



### NOTE

*TE has designed machines for a variety of application requirements. For assistance in setting up prototype and production line equipment, contact Tool Engineering through your local TE Representative or call Product Information at the number on the bottom of page 1.*

### 5.1. Hand Crimping Tools

Hand crimping tools are designed for prototype and low-volume applications such as repair of damaged terminals.

### 5.2. Applicators

Applicators are designed for the full wire size range of strip-fed, precision formed terminals, and provide for high volume, heavy duty production requirements. The applicators must be used in bench or floor model power units.



### NOTE

*Each applicator is shipped with a metal identification tag attached. Also, a packet of associated paperwork is included in each applicator shipment. Some changes may have to be made to the applicators to run in all related power units.*

### 5.3. Die Assemblies

Die assemblies are designed for easy installation and removal in hand tool frame assemblies or applicators.

### 5.4. Power Units

Power units are fully-automatic or semi-automatic machines used to assist in the application of a product. Power units include the power source used to supply the force to an applicator.



### NOTE

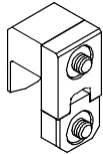
*AMP-O-LECTRIC Model "K" Terminating Machine 565435-5 has been superseded by Model "G" Terminating Machine 354500-1 for new applications. For existing applications, the Model "K" can still be used because of the large number of installed machines.*

### 5.5. Press/Applicator Setup Side-Movement Wear-Limit Check

This product should only be crimped with press/applicator combinations that have less than 0.010" side crimper movement (axial to wire). See Figure 10. Measure crimper movement directly beside or above crimp. With the power off, apply pressure to move crimper axially with the wire (toward and away from dial indicator with 0.001" resolution or finer). *Less than 0.010" total side movement at the crimper is required for this Ultra-FAST product family.* If larger wear is present, use a different press or contact the TE Connectivity GATD Tooling Group about press repair or replacement.

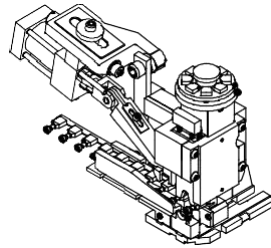


Figure 10

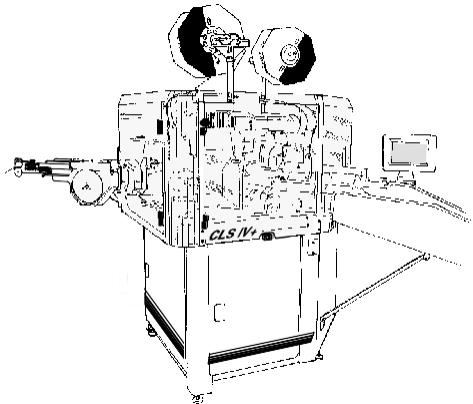


Typical Die Assembly  
(Refer to Table)

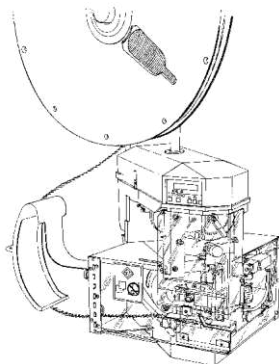
DIE ASSEMBLY (For Applicators)	INSTRUCTION SHEET
58268-1, 58268-2	408-9227
58269-2, 58269-3, 58269-4, 58269-5	408-9225
58308-1, 58308-2	408-9296



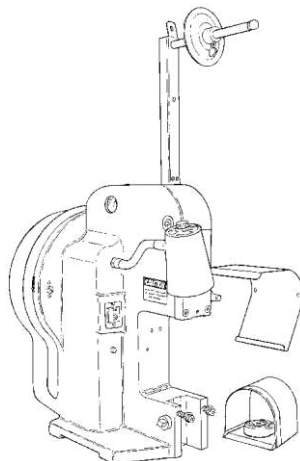
Typical Applicator  
(Refer to Table)



AMPOMATOR CLS IV+  
Lead-Making Machine  
356500-[ ] (409-5878)



AMP-O-LECTRIC Model "G"  
Terminating Machine 354500-1  
(409-5842)



AMP-O-LECTRIC Model "K"  
Terminating Machine 565435-5  
(409-5128)

APPLICATOR	INSTRUCTION SHEET
466778-3	408-8051
466778-4	408-8051, 408-9902
466778-6	408-8051
466779-3	408-8051
466779-4	408-8051, 408-9902
466779-6	408-8051
466784-1	408-8058
466784-2	408-8058
466785-1	408-8058
466785-2	408-8058
567041-1	408-8051
567041-2	408-8051, 408-9902
567041-4	408-8051
567082-1	408-8051
567082-2	408-8051, 408-9902
567083-1	408-8058
567083-2	408-8058
567085-1	408-8058
567085-2	408-8058
567111-1	408-8079
567111-2	408-8079
567111-3	408-8051
567112-1	408-8079
567112-2	408-8079
567112-3	408-8051
567117-1	408-8051
567117-2	408-8051, 408-9902
567142-1	—
567142-2	408-8051, 408-9902
567142-4	408-8051
567228-1	408-8058
567228-2	408-8058
567276-1	—
567276-2	408-8079
567276-4	408-8051
567460-1	408-8058
567494-1	—
567494-2	408-8058

Figure 11 (continued)

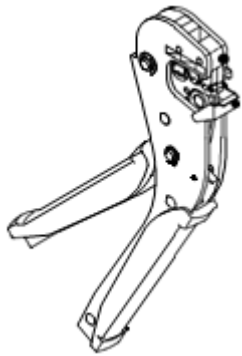
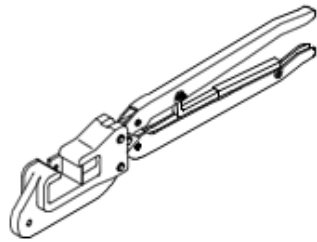
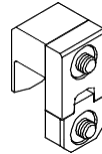
TERMINAL			APPLICATOR □ FOR POWER UNIT			DIE ASSEMBLIES FOR APPLICATOR	
SERIES	TYPE	WIRE RANGE (AWG)	AMP-O-LECTRIC Model "K" Machine 565435-5	AMP-O-LECTRIC Model "G" Machine 354500-1	AMPOMATOR CLS IV+ Machine 356500-[ ]	818058-2	818058-3
110/125	Receptacle	26 – 22	567082-2	—	567082-1 †	—	—
		22 – 18	567041-2	567041-4	567041-1	58269-2	—
		16 – 14	567117-2	—	567117-1	58269-3	—
	Plus Receptacle	22 – 18	567276-2	567276-4	567276-1	58268-1	—
187	Receptacle	22 – 18	466779-4	466779-6	466779-3	58269-2	—
		16 – 14	466778-4	466778-6	466778-3	58269-3	—
	Plus Receptacle	22 – 18	567111-2	567111-3	567111-1	58268-1	—
		16 – 14	567112-2	567112-3	567112-1	58268-2	—
	Tab	22 – 18	466779-4	466779-6	466779-3	58269-2	—
	Flag	22 – 18	567083-2	—	567083-1	—	58308-1
		16 – 14	567085-2	—	567085-1	—	58308-2
	Flag LID	16 – 14	—	—	567460-1	—	58308-2
205	Receptacle	22 – 18	466779-4	466779-6	466779-3	58269-2	—
	Flag	22 – 18	466784-2	—	466784-1	—	58308-1
250	Receptacle	22 – 18	466779-4	466779-6	466779-3	58269-2	—
		16 – 14	466778-4	466778-6	466778-3	58269-3	—
		12 – 10	567142-2	567142-4	567142-1	58269-4 ‡	—
	Plus Receptacle	22 – 18	567111-2	567111-3	567111-1	58268-1	—
		16 – 14	567112-2	567112-3	567112-1	58268-2	—
	Tab	22 – 18	466779-4	466779-6	466779-3	58269-2	—
		16 – 14	466778-4	466778-6	466778-3	58269-3	—
		12 – 10	567142-2	567142-4	567142-1	58269-4 ‡	—
	Plus Tab	22 – 18	567111-2	567111-3	567111-1	58268-1	—
		16 – 14	567112-2	567112-3	567112-1	58268-2	—
	Flag	22 – 18	466784-2	—	466784-1	—	58308-1
		16 – 14	466785-2	—	466785-1	—	58308-2
	Flag LID	22 – 18	567228-2	—	567228-1	—	58308-1
		16 – 14	567494-2	—	567494-1	—	58308-2

□ Applicators may be convertible from one machine to another. Contact the number at the bottom of page 1 for more information.

† Terminates wire size 22 AWG only.  
 ‡ Terminates wire size 12 AWG only.  
 ■ Terminates wire size 10 AWG only.

Figure 11 (continued)




 Hand Tool Frame 58078-3  
(408-6976) with Typical  
Die Assembly

 Hand Tool Frame  
69710-1 (408-2095)

 Typical Die Assembly  
(Refer to Table)

DIE ASSEMBLY (For Hand Tool Frames)	INSTRUCTION SHEET
58052-3	408-9277
58079-3	408-9278
58080-3	408-9278
90390-3	408-9279
90391-3	408-9279
224027-1	408-4153
224027-2	408-4153

TERMINAL			DIE ASSEMBLY FOR HAND TOOL FRAME	
SERIES	TYPE	WIRE RANGE (AWG)	58078-3	69710-1
110/125	Receptacle	26 – 22	58052-3	—
		22 – 18	90390-3	—
		16 – 14	90391-3	—
	Plus Receptacle	22 – 18	58079-3	—
187	Receptacle	22 – 18	90390-3	—
		16 – 14	90391-3	—
	Plus Receptacle	22 – 18	58079-3	—
		16 – 14	58080-3	—
	Flag Terminal	22 – 18	90390-3	—
		16 – 14	90391-3	—
Tab Terminal	22 – 18	90390-3	—	
250	Receptacle	22 – 18	90390-3 or 58079-3	—
		16 – 14	90391-3	—
		12 – 10	—	224027-1 ■
			—	224027-2 ‡ □
	Plus Receptacle	16 – 14	58080-3	—
	Flag Terminal	22 – 18	90390-3	—
		16 – 14	90391-3	—
	Tab Terminal	22 – 18	90390-3	—
		16 – 14	90391-3	—
		12 – 10	—	224027-2 ‡ □
		—	224027-1 ■	

□ This die assembly can also be used in 626 Pneumatic Tooling Assembly 189721-1 or 189722-1 (408-5862) when installed onto Straight Action Crimper 217200-1 (408-4105).

‡ Terminates wire size 12 AWG only.

■ Terminates wire size 10 AWG only.

Figure 11 (end)

## 6. VISUAL AID

Figure 12 shows a typical application of Ultra-Fast Fully-Insulated FASTON Terminals. This illustration should be used by production personnel to ensure a correctly applied product. Applications which DO NOT appear correct should be inspected using the information in the preceding pages of this specification and in the instructional material shipped with the product or tooling.

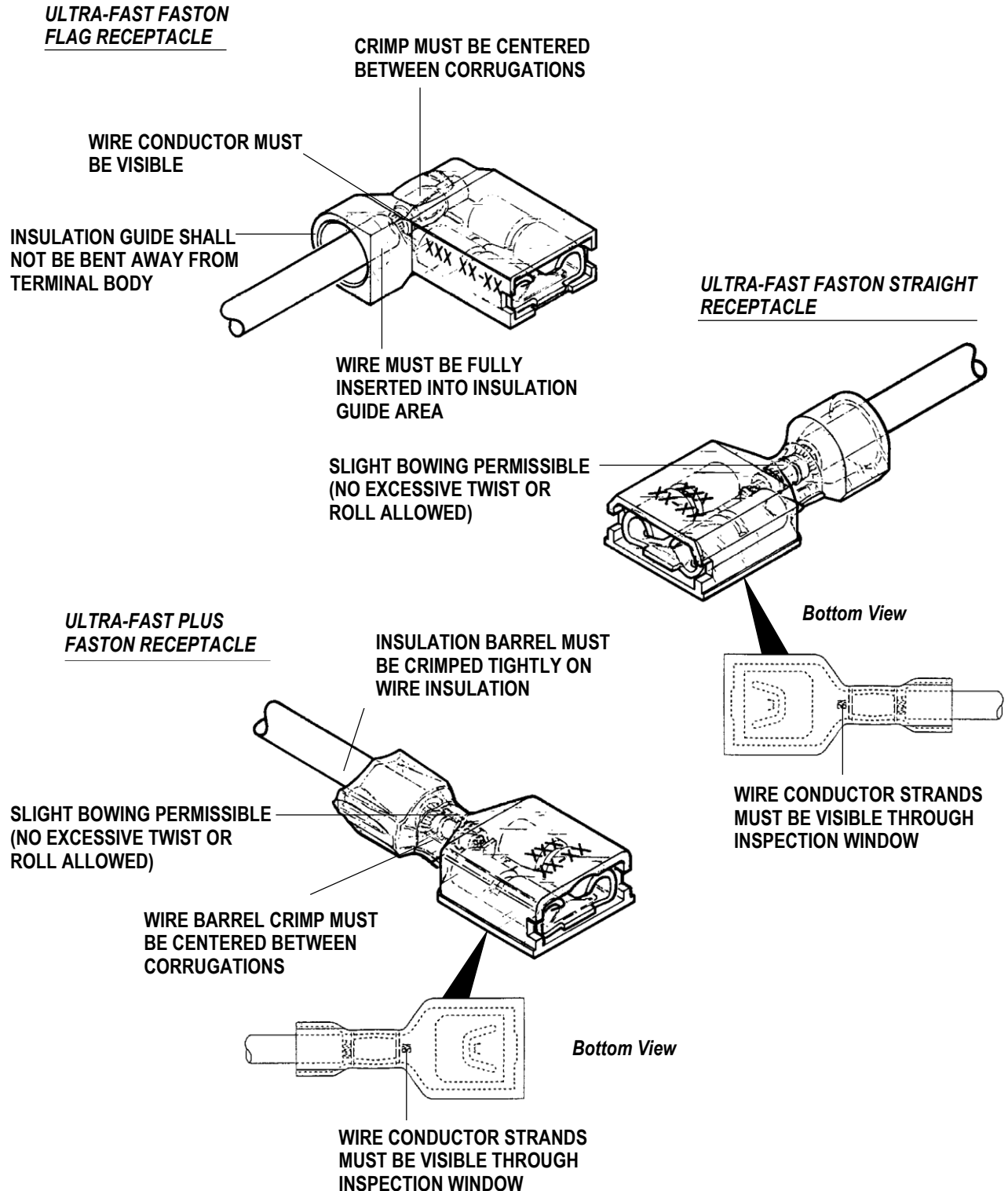


Figure 12: Visual Aid

单击下面可查看定价，库存，交付和生命周期等信息

[>>TE Connectivity\(泰科\)](#)