

To : VIVO MOBILE COMMUNICATION CO.,LTD

Specification number:EQM08-1KC-E17XK29

Date of issue: 24 October, 2017

## Multilayer ceramic Chip capacitor specification

Product Part No

CM02CG100J25AH

(Recipient stamp column)

Please send back with recipient stamp or signature here.

This specification would be invalidated unless sent back within a year after issue date of this specification.

**RoHS Compliant**

Kyocera Corporation  
Capacitor Division





**1.Scope:**

This specification sheet shall be applied to multilayer ceramic chip capacitors; Kyocera CM series.

**2.Nomenclature**

CM    □□    □□    □□□    □    □□    A    □  
 Series    (1)    (2)    (3)    (4)    (5)    (6)    (7)

- (1) : Size
- (2) : Temperature Characteristics
- (3) : Capacitance
- (4) : Tolerance
- (5) : Rated Voltage
- (6) : External Electrode
- (7) : Packaging

**(1)External Dimensions(Size)**

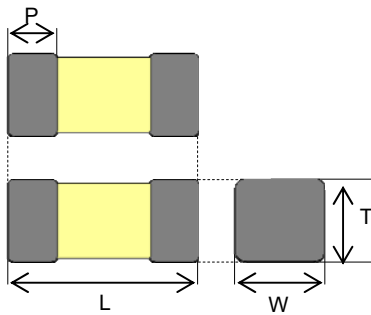

External Dimensions For Taping or Bulk. (unit:mm)

Type	L	W	T	P
02	0.40±0.02	0.20±0.02	0.20±0.02	0.07~0.14

**(2)Temperature Characteristics**

CG:0±30ppm/°C

Temperature coefficients are determined by calculation based on measurement at 20°C and 85°C.



**(3)Capacitance Value**

Capacitance is indicated by three numbers and a letter (see example as follows).

The first and second digits indicate the first two significant figures, and the final digit is a base 10 logarithmic multiplier in picofarads. When the nominal value is less than 10pF, the letter "R" is used to indicate the decimal point. The succeeding digit(s) of the group represent significant figure(s).

(Ex.)

Code	Capacitance
100	10pF

**(4)Tolerance**

Code	J
Tolerance	±5%

**(5)Rated Voltage**

Code	25
Voltage	25Vdc

**(6)Termination (External Electrode)**

A:Nickel Barrier / Tin

**(7)Packaging Configuration**

Code	Packaging Configuration	Applying Size
H	Taping(2mm Pitch. $\phi$ 180 Reel)	Refer to Taping specification

**3.Operating temperature range**

-55 to +125°C



## 4.Specifications and Test Methods

(Table 1-1)

Item		Specification	Measuring Conditions		
Temperature Characteristics		Refer to Item 2-(2)			
Capacitance		Within specified tolerance value	Capacitance	Frequency	Volt
Q(C:Nominal Capacitance)		C $\geq$ 30pF : Q $\geq$ 1000 C<30pF : Q $\geq$ 400+20C	C $\leq$ 1000pF	1MHz $\pm$ 10%	0.5~5Vrms
(*1)Insulation Resistance		Over 10000M $\Omega$ or 500M $\Omega$ · $\mu$ F, whichever is less	C:Nominal capacitance		
(*1)Dielectric Strength		Resist to the high voltage	After charging with the rated voltage for 1 minutes at room temperature and normal humidity.		
Appearance		No serious defect	Applying 3 times of the rated voltage for 1 to 5 seconds.		
End Termination Adherence		No evidence of peeling on the end termination	Under Microscope		
Resistance To Vibration		Appearance Capacitance Variation Q(C:Nominal Capacitance)	No serious defect Within specified tolerance value C $\geq$ 30pF : Q $\geq$ 1000 C<30pF : Q $\geq$ 400+20C		
Resistance to Solder Leaching		Appearance Capacitance Variation Q(C:Nominal Capacitance) (*1)Insulation Resistance (*1)Dielectric Strength	Vibration frequency:10 to 55 (Hz) Swing width :1.5mm Sweep :10 $\rightarrow$ 55 $\rightarrow$ 10 Hz/1min x,y,z axis 2 hours/each Total 6 hours (Refer to Fig.2)		
Solderability		Coverage $\geq$ 90% Each termination end	After dipped in solder solution, at 260 $\pm$ 5 $^{\circ}$ C for 10 $\pm$ 0.5 seconds and kept at room temperature and normal humidity for 24 $\pm$ 2 hours, the part will satisfy the specifications. *Pre-heat before immersion 1st: 80 $^{\circ}$ C to 100 $^{\circ}$ C for 120sec. 2st:150 $^{\circ}$ C to 200 $^{\circ}$ C for 120sec.		

(\*1)Insulation Resistance/Dielectric Strength;Charging or discharging current for these tests is limited under 50mA.

(Table 1-2)

Item		Specification	Measuring Conditions
Temperature cycling	Appearance	No serious defect	Repeat 5 cycles Room temperature(3 minutes)→ Minimum operating temperature(30 minutes) →Room temperature(3 minutes)→ Maximum operating temperature(30 minutes).  After being kept at room temperature and normal humidity for 24±2 hours, the part will satisfy the specification. (Refer to Fig.2)
	Capacitance Variation	±2.5% or ±0.25pF, whichever is larger	
	Q(C:Nominal Capacitance)	C≥30pF : Q≥1000 C<30pF : Q≥400+20C	
	(*1)Insulation Resistance	Over 10000MΩ or 500MΩ·μF, whichever is less	
	(*1)Dielectric Strength	Resist to the high voltage	
Load Humidity Resistance	Appearance	No serious defect	After applying rated voltage for 500+12/-0 hours in pre-condition at 40±2 °C, humidity 90 to 95%RH, allow parts to stabilize for 24±2 hours, at room temperature before measurement.
	Capacitance Variation	±7.5% or ±0.75pF, whichever is larger	
	Q(C:Nominal Capacitance)	C≥30pF : Q≥200 C<30pF : Q≥100+10C/3	
	(*1)Insulation Resistance	Over 500MΩ or 25MΩ·μF, whichever is less	
High Temperature Life Test	Appearance	No serious defect	After applying 2 times of rated voltage at the maximum operating temperature for 1,000+12/-0 hours, allow parts to stabilize for 24±2 hours, at room temperature before measurement.
	Capacitance Variation	±3% or ±0.3pF, whichever is larger	
	Q(C:Nominal Capacitance)	C≥30pF : Q≥350 30pF>C≥10pF : Q≥275+5C/2 C<10pF : Q≥200+10C	
	(*1)Insulation Resistance	Over 1000MΩ or 50MΩ·μF, whichever is less	
Bending Strength		No significant damage at 1mm bent	Refer to Fig.3-1, Fig.3-2 The glass epoxy board is bent up 1mm in 10 sec.

(Table3 Parts List)

Product Part No □:Tolerance code	Capacitance Series	Tolerance (□)	Dimension [mm]			Q min C:Nominal Capacitance	IR (initial) min
			L	W	T		
CM02CG100□25AH	-	J:±5%	0.40±0.02	0.20±0.02	0.20±0.02	400+20C	10000MΩ



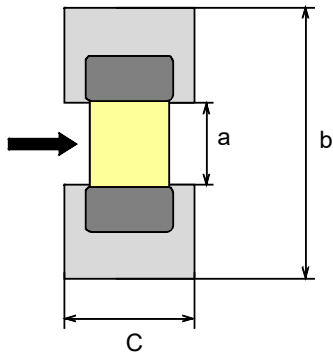

Fig.1 Substrate for adhesion strength test

type	a	b	C
02	0.15	0.50	0.20

glass epoxy board

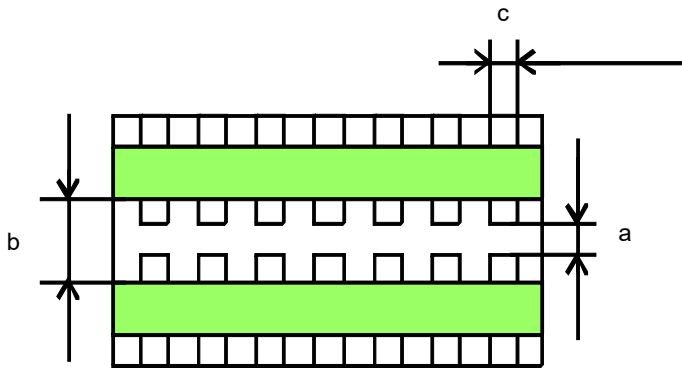

Fig.2 Substrate for temperature cycle test

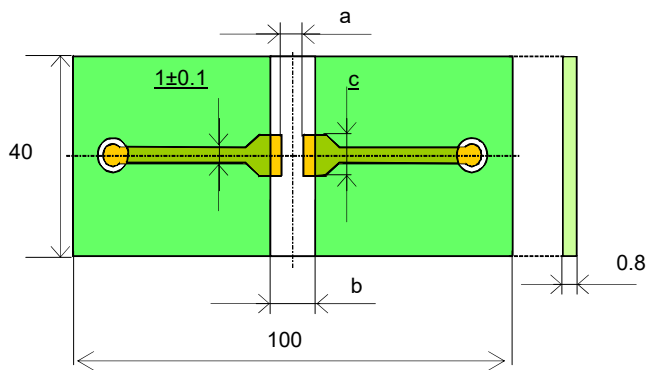

Fig.3-1 Substrate for bending test

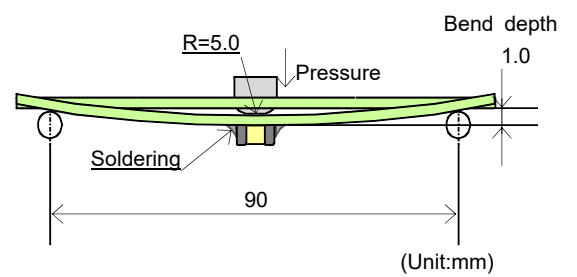
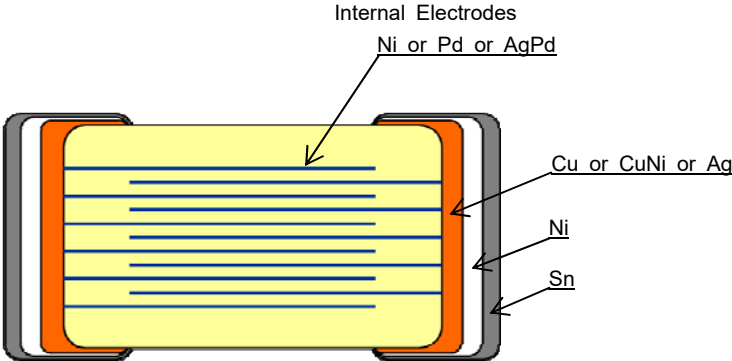

Fig.3-2 Testing status

[Structure]



[Production facility]

Kagoshima Kokubu plant





**Taping Specification**

**1.Application**

This specification applies to paper carrier tape of Kyocera multi-layer ceramic chip capacitor.

**2.Packing unit**

type	thickness (unit:mm)	material of carrier tape		width of carrier tape		Φ180 reel quantity per reel
		paper	Plastic	8mm	12mm	
02	0.20±0.02	○	-	○	-	20000

**3.Shape and dimintions**

**(1)Reel**

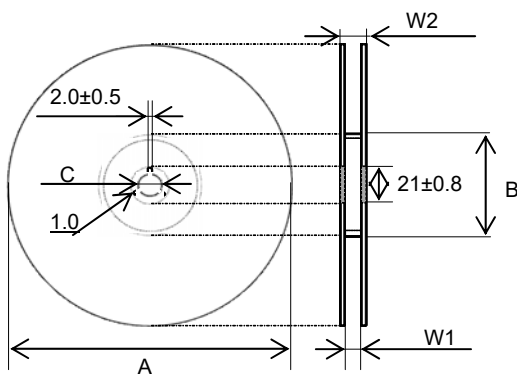

[Dimension]	(Unit:mm)		
	A	B	C
Φ180 reel (Code:H)	φ180+0/-2.0	φ60min	φ13.0±0.5
	W1	W2	
Φ180 reel (Code:H)	10.0±1.5	16.5max	

**(2)Carrier Tape**

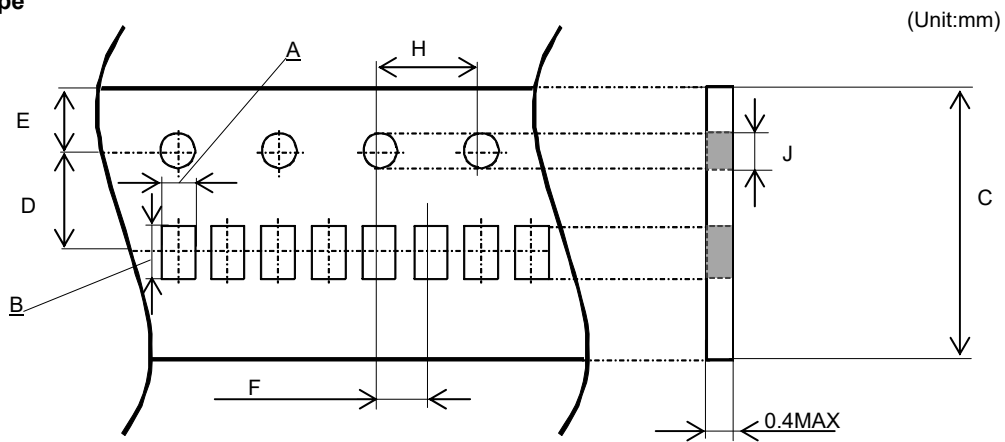

		(unit:mm)						
Code		A	B	C	D	E	H	J
Type	Tolerance	±0.03	±0.03	±0.3	±0.05	±0.1	±0.05	±0.1
02		0.25	0.45	8.0	3.5	1.75	2.0	4.0
								φ1.5



#### 4.Packing method

##### (1)Details of leader and trailer

- ①The tape will have a empty pocket at the leader and trailer of carrier tape.
- ②The tape end will not be stucked by glue in order to make it easier to peel off from reel.
- ③The feeding round hole will be on the right side against leading direction.

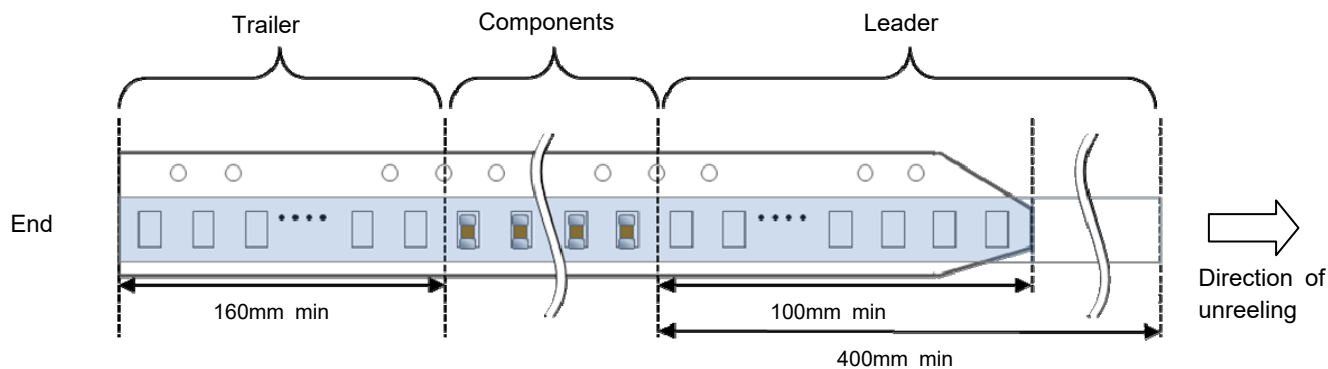

##### (2)Heat pressure tape

- ①Peeling strength to be 0.1~0.5N when peeling off the top tape by following method.
- ②When peeling top tape off, the glue will be stuck to the top tape side.
- ③Chip capacitor will not stuck on heat pressure tape and will be free in the cavity.

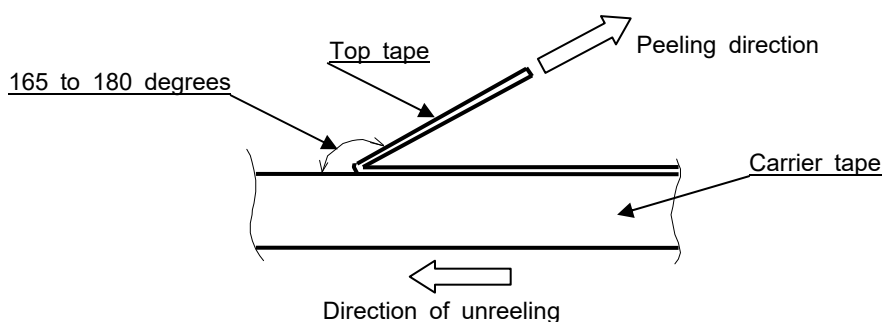

The peel-off angle:165~180 degree against the surface of carrier tape.  
The peel-off speed:300mm/min.

##### (3)Carrier tape

- ①Chip will not fall off from carrier tape or carrier tape will not be damaged by bending than within aradius of 25mm.
- ②The chip are inserted continuously without any empty pocket.
- ③Chip will not be mis-mounted because of too big clearance between components and cavity. Also the waste of carrier tape will not fill a nozzle hole of mouting machine.

#### 5.Indication and packing

- ①There will be following indication on one side of the reel: "PART NUMBER","LOT NUMBER", "QUANTITY","DATE OF MANUFACTURE","CUSTOMER'S NAME"
- ②There will be following indication on the reel box: "PART NUMBER","LOT NUMBER", "QUANTITY OF REEL","DATE OF MANUFACTURE","CUSTOMER'S NAME"
- ③We adequately pack the box to prevent chip capacitor from any mechanical damage during transportation.

## Precautions

## ■ Handling

- 1) Cracks may occur unless otherwise avoiding excessive stress to the capacitors by the load of an adsorption nozzle, and bending of a substrate at the time of mounting.
- 2) Please arrange the capacitor position where they don't have too much stress of board bending after mounting.
- 3) Please design that the form and size of the land pattern has suitable solder amount.  
Otherwise cracks may occur. The recommended fillet height shall be 1/2 to 1/3 of the thickness of capacitors.

## ■ Circuit Design

- 1) When AC voltage is superimposed on DC voltage, the zero-to-peak voltage shall not exceed the rated voltage. When the capacitor is to be employed in a circuit in which there is continuous application of a high frequency Voltage or a steep pulse voltage, even though it is within the rated voltage, please inquire to the manufacturer.
- 2) Please use the capacitor below the maximum temperature.  
When using the capacitor in a self-heating AC circuit, please make sure the surface of the capacitor remains under the maximum temperature for usage. Also, please make certain temperature rises remain below 20 °C.

## ■ Resin coating

Please use the resin of low curing shrinkage type. (Otherwise cracks may occur).

## ■ Storage

- 1) When the components is stored in minimal packaging (a heat-sealed or chuck-type plastic bag), the bag should be kept closed. Once the bag has been opened, reseal it or store it in a desiccator.
- 2) Keep storage place temperature +5 to +40 °C, humidity 20 to 70% RH.
- 3) The storage atmosphere must be free of gas containing sulfur and chlorine. Also, avoid exposing the product to saline moisture. If the product is exposed to such atmospheres, the terminals will oxidize and solderability will be effected.
- 4) Precautions 1) to 3) apply to chip capacitors packaged in carrier tapes and bulk cases.
- 5) The solderability is assured for 6 months from our shipping date if the above storage precautions are followed.

## ■ Application Restriction

Please consult with us before using a capacitor in the equipment which requires a high degree reliability (medical equipment, aerospace applications, nuclear equipment.) Malfunctions in medical, space, nuclear power or other vital equipment may result in death or great social losses. Capacitors designed specially with high reliability are used for the equipment above.

## ■ Export regulation

When the applying products relate the strategic materials which are provided in Foreign Exchange and Foreign Trade Act and Foreign Trade Management Law, the export license based on these laws are required.

## ■ Disposal

Please dispose the capacitors according to the relating laws about the waste treatment and cleaning. Safety application guideline and detailed information of electrical properties are also provided in Kyocera home page:

URL: <http://www.kyocera.co.jp/electronic>

## Notice:

This specification shall guarantee only monolithic capacitors. Please make sure the performance of capacitors after mounted on the assembled product.

Any failures occurred being used out of this specification shall not be guaranteed.

This specification shall be applied to the products purchased through the regular sales routes, such as the sale offices, the subsidiaries and the distributors, etc.).



单击下面可查看定价，库存，交付和生命周期等信息

[>>Kyocera\(京瓷\)](#)