



SY5800D

Single Stage Flyback And PFC Controller With Primary Side Control For LED Lighting *Preliminary datasheet*

General Description

The SY5800D is a single stage Flyback and PFC controller targeting at LED lighting applications. It is a primary side controller without applying any secondary feedback circuit for low cost, and drives the Flyback converter in the quasi-resonant mode to achieve higher efficiency. It keeps the Flyback converter in constant on time operation to achieve high power factor.

Ordering Information

SY5800 □(□□)□
 □ Temperature Code
 □ Package Code
 □ Optional Spec Code

Temperature Range: -40°C to 105°C

| Ordering Number | Package type | Note |
|-----------------|--------------|------|
| SY5800DFAC | SO8 | ---- |

Features

- Primary side control eliminates the opto-coupler.
- Valley turn-on of the primary MOSFET to achieve low switching losses
- CV mode when open LED
- 0.3V primary current sense reference voltage leads to a lower sense resistance thus a lower conduction loss.
- Internal high current MOSFET driver: 1A sourcing and 2A sinking
- Low start up current: 15µA typical
- Reliable short LED protection
- Power factor >0.90 with single-stage conversion.
- Compact package: SO8

Applications

- LED lighting
- Down light
- Tube lamp
- PAR lamp
- Bulb

Typical Applications

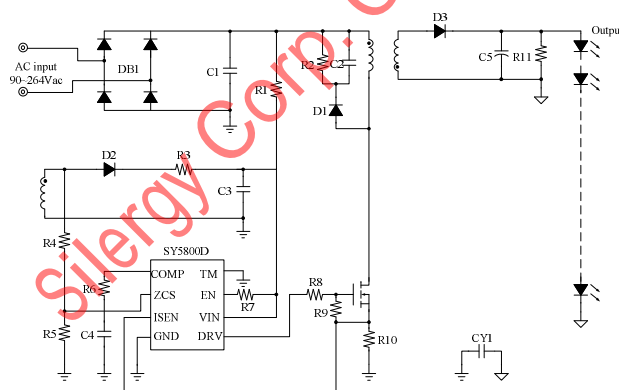

Fig1. Schematic Diagram

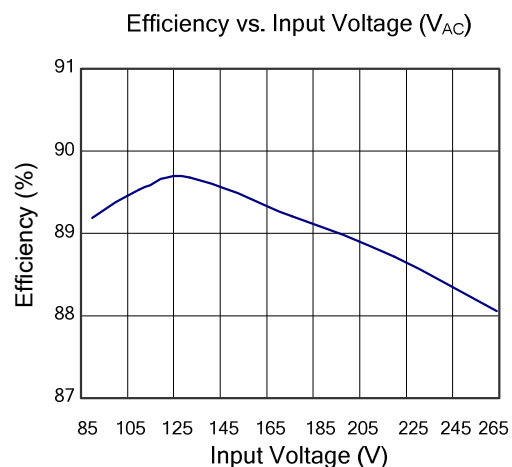
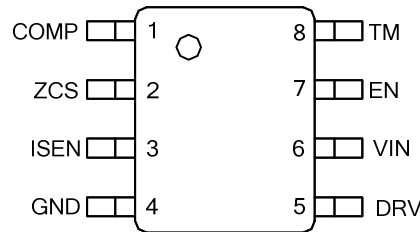

Figure 2. Efficiency vs Input Voltage

Pinout (top view)



(SO8)

Top Mark: AHSxyz for SY5800DFAC (device code: AHS, x=year code, y=week code, z=lot number code)

| Pin Name | Pin number SO8 | Pin Description |
|----------|----------------|---|
| COMP | 1 | Loop compensation pin. Connect a RC network across this pin and ground to stabilize the control loop. |
| ZCS | 2 | Inductor current zero-crossing detection pin. This pin receives the auxiliary winding voltage by a resistor divider and detects the inductor current zero crossing point. This pin also provides over voltage protection and line regulation modification function simultaneously. Good line regulation can be achieved by adjusting the upper resistor of the divider. |
| ISEN | 3 | Current sense pin. Connect this pin to the source of the primary switch. Connect the sense resistor across the source of the primary switch and the GND pin. (current sense resistor R_s : $R_s = k \frac{V_{REF} \times N_{PS}}{I_{OUT}}$, $k=0.167$) |
| GND | 4 | Ground pin |
| DRV | 5 | Gate driver pin. Connect this pin to the gate of primary MOSFET. |
| VIN | 6 | Power supply pin. This pin also provides output over voltage protection along with ZCS pin. |
| EN | 7 | Enable pin. Enable the IC by pulling the voltage on this pin above $V_{EN,ON}$ and Shut down the IC by pulling the voltage on this pin below $V_{EN,OFF}$. If not used, connect this pin to VIN pin with a resistor (470kΩ is recommended). |
| TM | 8 | Connected to ground. |

Absolute Maximum Ratings (Note 1)

| | | |
|--|-------|-----------------------------|
| VIN, DRV | ----- | -0.3V~19V |
| Supply Current I _{VIN} | ----- | 30mA |
| EN, ZCS | ----- | -0.3V~V _{IN} +0.3V |
| ISEN, COMP, TM | ----- | -0.3V~3.6V |
| Power Dissipation, @ T _A = 25°C SO8 | ----- | 0.8W |
| Package Thermal Resistance (Note 2) | | |
| SO8, θ _{JA} | ----- | 88°C/W |
| SO8, θ _{JC} | ----- | 45°C/W |
| Temperature Range | ----- | -45°C to 150°C |
| Lead Temperature (Soldering, 10 sec.) | ----- | 260°C |
| Storage Temperature Range | ----- | -65°C to 150°C |

Recommended Operating Conditions (Note 3)

| | | |
|----------------------------|-------|----------------|
| VIN, DRV | ----- | 8V~15.4V |
| Junction Temperature Range | ----- | -40°C to 125°C |
| Ambient Temperature Range | ----- | -40°C to 105°C |

Block Diagram

Fig3. Block Diagram

Electrical Characteristics

($V_{IN} = 12V$ (Note 3), $T_A = 25^\circ C$ unless otherwise specified)

| Parameter | Symbol | Test Conditions | Min | Typ | Max | Unit |
|----------------------------------|----------------|-------------------------|-------|-------------------|-------|------------|
| Power Supply Section | | | | | | |
| Input voltage range | V_{VIN} | | 8 | | 15.4 | V |
| VIN turn-on threshold | $V_{VIN,ON}$ | | | | 17.6 | V |
| VIN turn-off threshold | $V_{VIN,OFF}$ | | 6.0 | | 7.9 | V |
| VIN OVP voltage | $V_{VIN,OVP}$ | | | $V_{VIN,ON}+0.85$ | | V |
| Start up Current | I_{ST} | $V_{VIN} < V_{VIN,OFF}$ | | 15 | | μA |
| Operating Current | I_{VIN} | $C_L=100pF, f=15kHz$ | | 1 | | mA |
| Shunt current in OVP mode | $I_{VIN,OVP}$ | $V_{VIN} > V_{VIN,OVP}$ | 1.6 | 2 | 2.5 | mA |
| Error Amplifier Section | | | | | | |
| Internal reference voltage | V_{REF} | | 0.294 | 0.3 | 0.306 | V |
| Current Sense Section | | | | | | |
| Current limit reference voltage | $V_{ISEN,MAX}$ | | | 0.5 | | V |
| ZCS pin Section | | | | | | |
| ZCS pin OVP voltage | $V_{ZCS,OVP}$ | | | 1.31 | | V |
| ZCS pin reference voltage | $V_{ZCS,REF}$ | | | 1.25 | | V |
| Sleep mode voltage ON threshold | $V_{COMP-ON}$ | | | 0.36 | | V |
| Sleep mode voltage OFF threshold | $V_{COMP-OFF}$ | | | 0.30 | | V |
| Gate Driver Section | | | | | | |
| Gate driver voltage | V_{Gate} | | | V_{VIN} | | V |
| Maximum source current | I_{SOURCE} | | | 1 | | A |
| Minimum sink current | I_{SINK} | | | 2 | | A |
| Max ON Time | $T_{ON,MAX}$ | $V_{COMP}=1.5V$ | | 24 | | μs |
| Min ON Time | $T_{ON,MIN}$ | | | 400 | | ns |
| Max OFF Time | $T_{OFF,MAX}$ | | | 39 | | μs |
| Min OFF Time | $T_{OFF,MIN}$ | | | 1 | | μs |
| Maximum switching frequency | f_{MAX} | | | 120 | | kHz |
| Enable function Section | | | | | | |
| Enable ON | $V_{EN,ON}$ | | | 1.5 | | V |
| Enable OFF | $V_{EN,OFF}$ | | | 0.2 | | V |
| Thermal Section | | | | | | |
| Thermal Shutdown Temperature | T_{SD} | | | 150 | | $^\circ C$ |

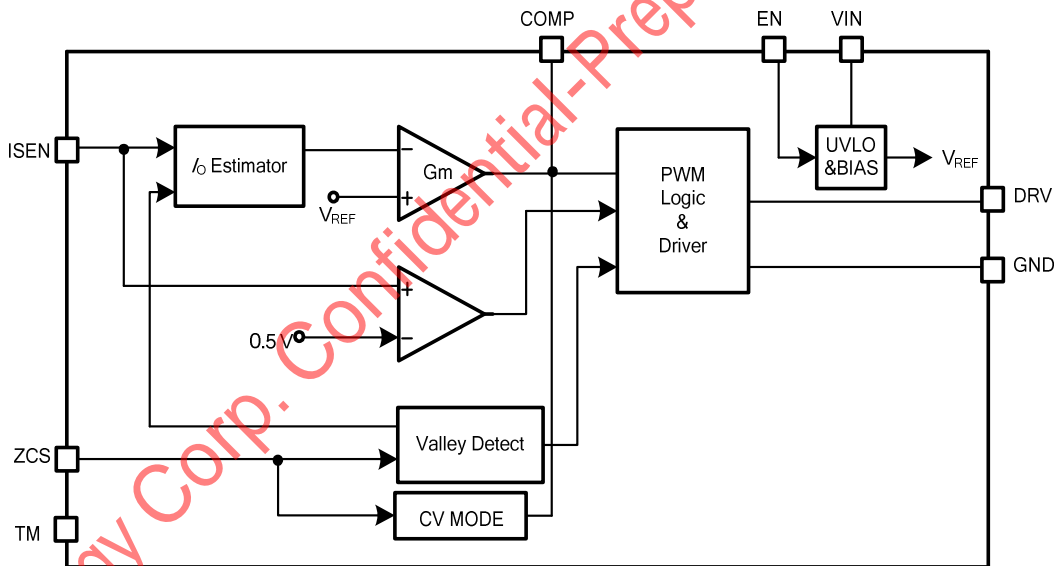
Note 1: Stresses beyond the “Absolute Maximum Ratings” may cause permanent damage to the device. These are stress ratings only. Functional operation of the device at these or any other conditions beyond those indicated in the operational sections of the specification is not implied. Exposure to absolute maximum rating conditions for extended periods may affect device reliability.

Note 2: Θ_{JA} is measured in the natural convection at $T_A = 25^\circ C$ on a low effective single layer thermal conductivity test board of JEDEC 51-3 thermal measurement standard. Test condition: Device mounted on 2” x 2” FR-4 substrate PCB, 2oz copper, with minimum recommended pad on top layer and thermal vias to bottom layer ground plane.

Note 3: Increase VIN pin voltage gradually higher than $V_{VIN,ON}$ voltage then turn down to 12V.

Operation

SY5800D is a constant current Flyback controller with primary side control and PFC function that targets at LED lighting applications.

The Device provides primary side control to eliminate the opto-couplers or the secondary feedback circuits, which would cut down the cost of the system.

High power factor is achieved by constant on operation mode, with which the control scheme and the circuit structure are both simple.

In order to reduce the switching losses and improve EMI performance, Quasi-Resonant switching mode is applied, which means to turn on the power MOSFET at voltage valley; the start up current of SY5800D is rather small (15μA typically) to reduce the standby power loss further; the maximum switching frequency is clamped to 120kHz to reduce switching losses and improve EMI performance when the converter is operated at light load condition.

SY5800D operates in CV mode when LED is open. SY5800D provides reliable protections such as Short Circuit Protection (SCP), Over Temperature Protection (OTP), etc.

SY5800D is available with SO8 package.

Applications Information

Start up

After AC supply or DC BUS is powered on, the capacitor C_{VIN} across VIN and GND pin is charged up by BUS voltage through a start up resistor R_{ST} . Once V_{VIN} rises up to V_{VIN_ON} , the internal blocks start to work. V_{VIN} will be pulled down by internal consumption of IC until the auxiliary winding of Flyback transformer could supply enough energy to maintain V_{VIN} above V_{VIN_OFF} .

The whole start up procedure is divided into two sections shown in Fig.4. t_{STC} is the C_{VIN} charged up section, and t_{STO} is the output voltage built-up section. The start up time t_{ST} composes of t_{STC} and t_{STO} , and usually t_{STO} is much smaller than t_{STC} .

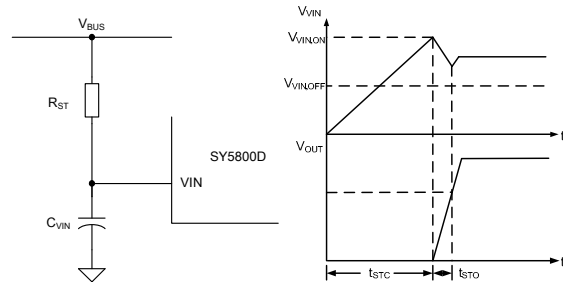

Fig.4 Start up

The start up resistor R_{ST} and C_{VIN} are designed by rules below:

- (a) Preset start-up resistor R_{ST} , make sure that the current through R_{ST} is larger than I_{ST} and smaller than I_{VIN_OVP}

$$\frac{V_{BUS}}{I_{VIN_OVP}} < R_{ST} < \frac{V_{BUS}}{I_{ST}} \quad (1)$$

Where V_{BUS} is the BUS line voltage.

- (b) Select C_{VIN} to obtain an ideal start up time t_{ST} , and ensure the output voltage is built up at one time.

$$C_{VIN} = \frac{\left(\frac{V_{BUS}}{R_{ST}} - I_{ST}\right) \times t_{ST}}{V_{VIN_ON}} \quad (2)$$

- (d) If the C_{VIN} is not big enough to build up the output voltage at one time. Increase C_{VIN} and decrease R_{ST} , go back to step (a) and redo such design flow until the ideal start up procedure is obtained.

Internal pre-charge design for quick start up

After V_{VIN} exceeds V_{VIN_ON} , V_{COMP} is pre-charged by an internal current source. The PWM block won't start to output PWM signals until V_{COMP} is over the initial voltage V_{COMP_IC} , which can be programmed by R_{COMP} . Such design is meant to reduce the start up time shown in Fig.5.

The voltage pre-charged V_{COMP_IC} in start-up procedure can be programmed by R_{COMP}

$$V_{COMP_IC} = 600mV - 300\mu A \times R_{COMP} \quad (3)$$

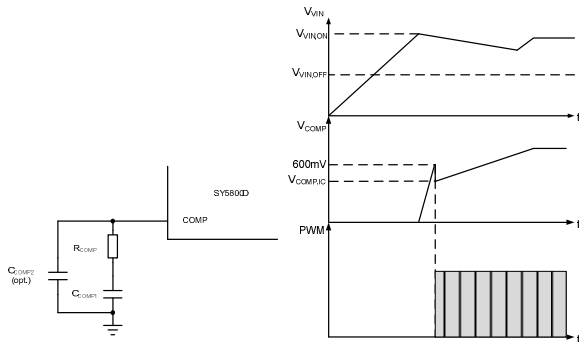
Fig.5 pre-charge scheme in start up

Where $V_{COMP-IC}$ is the pre-charged voltage of COMP pin.

Generally, a big capacitance of C_{COMP} is necessary to achieve high power factor and stabilize the system loop ($1\mu F \sim 2\mu F$ recommended); The voltage pre-charged in start-up procedure can be programmed by R_{COMP} ; On the other hand, larger R_{COMP} can provide larger phase margin for the control loop; A small ceramic capacitor is added to suppress high frequency interruption ($10pF \sim 100pF$ is recommended if necessary)

Shut down

After AC supply or DC BUS is powered off, the energy stored in the BUS capacitor will be discharged. When the auxiliary winding of Flyback transformer can not supply enough energy to VIN pin, V_{VIN} will drop down. Once V_{VIN} is below $V_{VIN-OFF}$, the IC will stop working and V_{COMP} will be discharged to zero.

Primary-side constant-current control

Primary side control is applied to eliminate secondary feedback circuit or opto-coupler, which reduces the circuit cost. The switching waveforms are shown in Fig.6.

The output current I_{OUT} can be represented by,

$$I_{OUT} = \frac{I_{SP}}{2} \times \frac{t_{DIS}}{t_s} \quad (4)$$

Where I_{SP} is the peak current of the secondary side; t_{DIS} is the discharge time of Flyback transformer; t_s is the switching period.

The secondary peak current is related with primary peak current, if the effect of the leakage inductor is neglected.

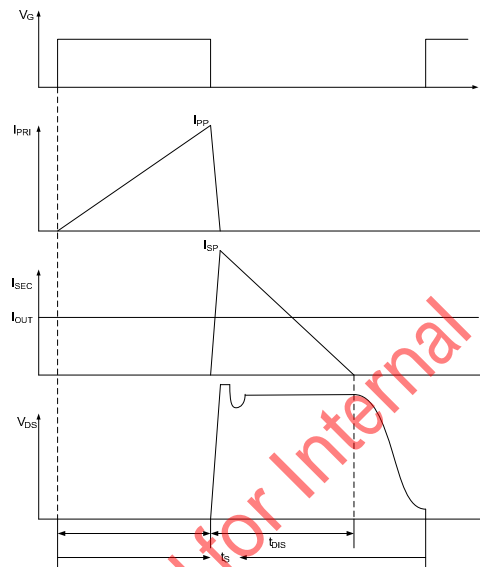
Fig.6 switching waveforms

$$I_{SP} = N_{PS} \times I_{PP} \quad (5)$$

Where N_{PS} is the turns ratio of primary to secondary of the Flyback transformer.

Thus, I_{OUT} can be represented by

$$I_{OUT} = \frac{N_{PS} \times I_{PP}}{2} \times \frac{t_{DIS}}{t_s} \quad (6)$$

The primary peak current I_{PP} and inductor current discharge time t_{DIS} can be detected by Source and ZCS pin, which is shown in Fig.7. These signals are processed and applied to the negative input of the gain modulator. In static state, the positive and negative inputs are equal.

$$V_{REF} = I_{PP} \times R_S \times \frac{t_{DIS}}{t_s} \times k_1 \quad (7)$$

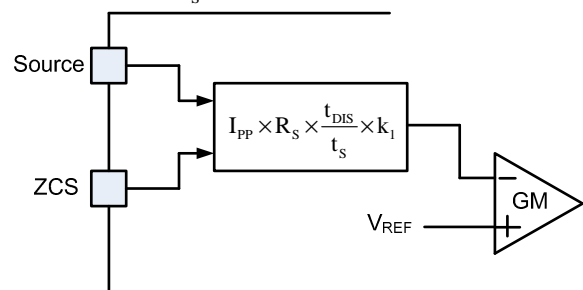
Fig.7 Output current detection diagram

Finally, the output current I_{OUT} can be represented by

$$I_{OUT} = \frac{V_{REF} \times N_{PS}}{R_S \times 2 \times k_1} \quad (8)$$

Where k_1 is the output current weight coefficient; V_{REF} is the internal reference voltage; R_S is the current sense resistor.

k_1 , and V_{REF} are all internal constant parameters, I_{OUT} can be programmed by N_{PS} and R_S .

$$R_S = \frac{V_{REF} \times N_{PS}}{I_{OUT} \times 2 \times k_1} \quad (9)$$

then

$$R_S = \frac{k \times V_{REF} \times N_{PS}}{I_{OUT}}, \quad k = \frac{1}{2k_1} \quad (10)$$

Quasi-Resonant Operation

QR mode operation provides low turn-on switching losses for Flyback converter.

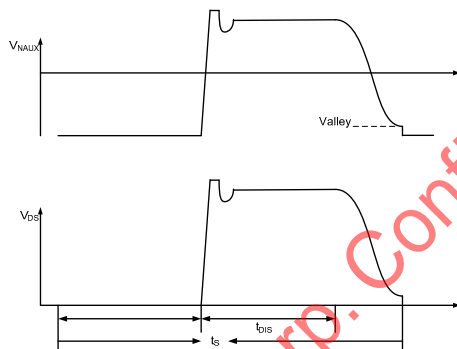

Fig.8 QR mode operation

The voltage across drain and source of the primary MOSFET is reflected by the auxiliary winding of the Flyback transformer. ZCS pin detects the voltage across the auxiliary winding by a resistor divider. When the voltage across drain and source of the primary MOSFET is at voltage valley, the MOSFET would be turned on.

Over Voltage Protection (OVP) & Open LED Protection (OLP)

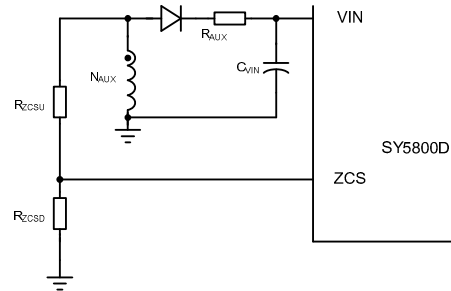

Fig.9 OVP&OLP

Over voltage protection

The output voltage is reflected by the auxiliary winding voltage of the Flyback transformer. When over output voltage happens and the feedback voltage V_{ZCS} is higher than $V_{ZCS,REF}$, V_{COMP} will be pulled down by an internal current source to decrease the output power.

Open LED protection

When LED is open, although V_{COMP} is pulled down, the output power is still larger than the load needed, and the output voltage still rises up; once the feedback voltage V_{ZCS} is higher than $V_{ZCS,OLP}$, Open LED Protection (OLP) mode is triggered. At OLP mode, the PWM block stops working and V_{COMP} will be pulled down by an internal current source until V_{COMP} is lower than $V_{COMP,ON}$. When V_{COMP} is lower than $V_{COMP,ON}$, the system enters into sleep mode, and V_{COMP} will be pulled up by Constant Current control again. The PWM block will rework after V_{COMP} is higher than $V_{COMP,OFF}$.

V_{VIN} also provide over voltage protection by V_{VIN_OVP} . When V_{VIN} exceeds V_{VIN_OVP} , the over voltage protection is triggered and the IC will discharge V_{VIN} by an internal current source I_{VIN_OVP} .

$$\frac{V_{ZCS_OVP}}{V_{OVP}} = \frac{N_{AUX}}{N_S} \times \frac{R_{ZCSD}}{R_{ZCSU} + R_{ZCSD}} \quad (9)$$

$$\frac{V_{VIN_OVP}}{V_{OVP}} \geq \frac{N_{AUX}}{N_S} \quad (10)$$

Where V_{OVP} is the output over voltage specification; R_{ZCSU} and R_{ZCSD} compose the resistor divider. The turns ratio of N_S to N_{AUX} and the ratio of R_{ZCSU} to R_{ZCSD} could be induced from equation (9) and (10).

Short Circuit Protection (SCP)

When the output is shorted to ground, the output voltage is clamped to zero. The voltage of the auxiliary winding

is proportional to the output winding, so V_{VIN} will drop down without auxiliary winding supply. Once V_{VIN} is below $V_{VIN,OFF}$, the IC will shut down and be charged again by the BUS voltage through the start up resistor. If the short circuit condition still exists, the system will operate in hiccup mode.

In order to guarantee SCP function not effected by voltage spike of auxiliary winding, a filter resistor R_{AUX} is needed (10Ω typically) shown in Fig.9.

Line regulation modification

The IC provides line regulation modification function to improve line regulation performance.

Due to the sample delay of ISEN pin and other internal delay, the output current increases with increasing input BUS line voltage. A small compensation voltage ΔV_{ISEN-C} is added to ISEN pin during ON time to improve such performance. This ΔV_{ISEN-C} is adjusted by the upper resistor of the divider connected to ZCS pin.

$$\Delta V_{ISEN,C} = V_{BUS} \times \frac{N_{AUX}}{N_P} \times \frac{1}{R_{ZCSU}} \times k_3 \quad (11)$$

Where R_{ZCSU} is the upper resistor of the divider; k_3 is an internal constant as the modification coefficient.

The compensation is mainly related with R_{ZCSU} , larger compensation is achieved with smaller R_{ZCSU} . Normally, R_{ZCS} ranges from 100kΩ~1MΩ.

Then R_{ZCSD} can be selected by,

$$\frac{V_{ZCS_OVP}}{V_{OUT}} \times \frac{N_S}{N_{AUX}} \times R_{ZCSU} > R_{ZCSD} \quad (12),$$

$$1 - \frac{V_{ZCS_OVP}}{V_{OUT}} \times \frac{N_S}{N_{AUX}}$$

And,

$$R_{ZCSD} \leq \frac{V_{ZCS_OVP}}{V_{OVP}} \times \frac{N_S}{N_{AUX}} \times R_{ZCSU} \quad (13)$$

$$1 - \frac{V_{ZCS_OVP}}{V_{OVP}} \times \frac{N_S}{N_{AUX}}$$

Where V_{OVP} is the output over voltage protection specification; V_{OUT} is the rated output voltage; R_{ZCSU} is the upper resistor of the divider; N_S and N_{AUX} are the turns of secondary winding and auxiliary winding separately.

Power Device Design

MOSFET and Diode

When the operation condition is with maximum input voltage and full load, the voltage stress of MOSFET and secondary power diode is maximized;

$$V_{MOS_DS_MAX} = \sqrt{2}V_{AC_MAX} + N_{PS} \times (V_{OUT} + V_{D,F}) + \Delta V_S \quad (14)$$

$$V_{D_R_MAX} = \frac{\sqrt{2}V_{AC_MAX}}{N_{PS}} + V_{OUT} \quad (15)$$

Where V_{AC_MAX} is maximum input AC RMS voltage; N_{PS} is the turns ratio of the Flyback transformer; V_{OUT} is the rated output voltage; $V_{D,F}$ is the forward voltage of secondary power diode; ΔV_S is the overshoot voltage clamped by RCD snubber during OFF time.

When the operation condition is with minimum input voltage and full load, the current stress of MOSFET and power diode is maximized.

$$I_{MOS_PK_MAX} = I_{P_PK_MAX} \quad (16)$$

$$I_{MOS_RMS_MAX} = I_{P_RMS_MAX} \quad (17)$$

$$I_{D_PK_MAX} = N_{PS} \times I_{P_PK_MAX} \quad (18)$$

$$I_{D_AVG} = I_{OUT} \quad (19)$$

Where $I_{P_PK_MAX}$ and $I_{P_RMS_MAX}$ are maximum primary peak current and RMS current, which will be introduced later.

Transformer (N_{PS} and L_M)

N_{PS} is limited by the electrical stress of the power MOSFET:

$$N_{PS} \leq \frac{V_{MOS,(BR)DS} \times 90\% - \sqrt{2}V_{AC_MAX} - \Delta V_S}{V_{OUT} + V_{D,F}} \quad (20)$$

Where $V_{MOS,(BR)DS}$ is the breakdown voltage of the power MOSFET.

In Quasi-Resonant mode, each switching period cycle t_s consists of three parts: current rising time t_1 , current

falling time t_2 and quasi-resonant time t_3 shown in

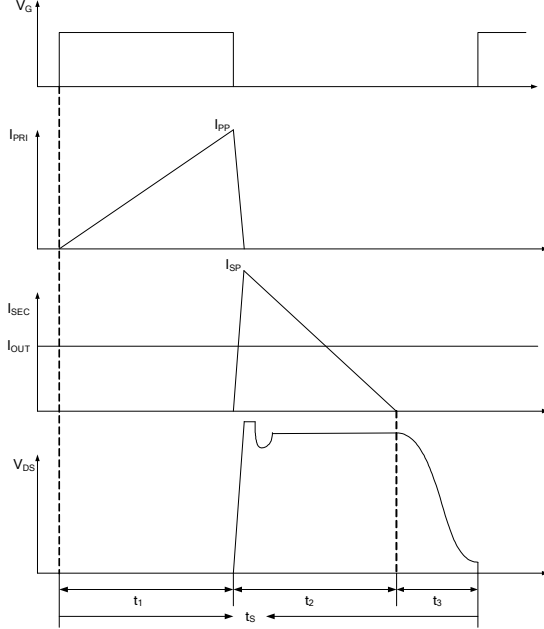

Fig.9 switching waveforms

The system operates in the constant on time mode to achieve high power factor. The ON time increases with the input AC RMS voltage decreasing and the load increasing. When the operation condition is with minimum input AC RMS voltage and full load, the ON time is maximized. On the other hand, when the input voltage is at the peak value, the OFF time is maximized. Thus, the minimum switching frequency f_{S_MIN} happens at the peak value of input voltage with minimum input AC RMS voltage and maximum load condition; Meanwhile, the maximum peak current through MOSFET and the transformer happens.

Once the minimum frequency f_{S_MIN} is set, the inductance of the transformer could be induced. The design flow is shown as below:

(a) Select N_{PS}

$$N_{PS} \leq \frac{V_{MOS_BR/DS} \times 90\% - \sqrt{2}V_{AC_MAX} - \Delta V_S}{V_{OUT} + V_{D,F}} \quad (21)$$

(b) Preset minimum frequency f_{S_MIN}

(c) Compute relative t_s , t_1 (t_3 is omitted to simplify the design here)

$$t_s = \frac{1}{f_{S_MIN}} \quad (22)$$

$$t_1 = \frac{t_s \times N_{PS} \times (V_{OUT} + V_{D,F})}{\sqrt{2}V_{AC_MIN} + N_{PS} \times (V_{OUT} + V_{D,F})} \quad (23)$$

(d) Design inductance L_M

$$L_M = \frac{V_{AC_MIN}^2 \times t_1^2 \times \eta}{2P_{OUT} \times t_s} \quad (24)$$

(e) Compute t_3

$$t_3 = \pi \times \sqrt{L_M \times C_{Drain}} \quad (25)$$

Where C_{Drain} is the parasitic capacitance at drain of MOSFET.

(f) Compute primary maximum peak current $I_{P_PK_MAX}$ and RMS current $I_{P_RMS_MAX}$ for the transformer fabrication.

$$I_{P_PK_MAX} = \frac{2P_{OUT} \times \left[\frac{L_M}{\sqrt{2}V_{AC_MIN}} + \frac{L_M}{N_{PS} \times (V_{OUT} + V_{D,F})} \right]}{L_M \times \eta} + \sqrt{\frac{4P_{OUT}^2 \times \left[\frac{L_M}{\sqrt{2}V_{AC_MIN}} + \frac{L_M}{N_{PS} \times (V_{OUT} + V_{D,F})} \right]^2 + 4L_M \times \eta \times P_{OUT} \times t_3}{L_M \times \eta}} \quad (26)$$

Where η is the efficiency; P_{OUT} is rated full load power

Adjust t_1 and t_s to t_1' and t_s' considering the effect of t_3

$$t_s' = \frac{\eta \times L_M \times I_{P_PK_MAX}^2}{4P_{OUT}} \quad (27)$$

$$t_1' = \frac{L_M \times I_{P_PK_MAX}}{\sqrt{2}V_{AC_MIN}} \quad (28)$$

$$I_{P_RMS_MAX} \approx \sqrt{\frac{t_1'}{6t_s'}} \times I_{P_PK_MAX} \quad (29)$$

(g) Compute secondary maximum peak current $I_{S_PK_MAX}$ and RMS current $I_{S_RMS_MAX}$ for the transformer fabrication.

$$I_{S_PK_MAX} = N_{PS} \times I_{P_PK_MAX} \quad (30)$$

$$t_2' = t_s' - t_1' - t_3 \quad (31)$$

$$I_{S_RMS_MAX} \approx \sqrt{\frac{t'_2}{6t'_s}} \times I_{S_PK_MAX} \quad (32)$$

Transformer design (N_P, N_S, N_{AUX})

The design of the transformer is similar with ordinary Flyback transformer. the parameters below are necessary:

| Necessary parameters | |
|-------------------------------|-------------------|
| Turns ratio | N_{PS} |
| Inductance | L_M |
| Primary maximum current | $I_{P_PK_MAX}$ |
| Primary maximum RMS current | $I_{P_RMS_MAX}$ |
| Secondary maximum RMS current | $I_{S_RMS_MAX}$ |

The design rules are as followed:

(a) Select the magnetic core style, identify the effective area A_e .

(b) Preset the maximum magnetic flux ΔB

$$\Delta B = 0.22 \sim 0.26 T$$

(c) Compute primary turn N_P

$$N_P = \frac{L_M \times I_{P_PK_MAX}}{\Delta B \times A_e} \quad (33)$$

(d) Compute secondary turn N_S

$$N_S = \frac{N_P}{N_{PS}} \quad (34)$$

(e) compute auxiliary turn N_{AUX}

$$N_{AUX} = N_S \times \frac{V_{VIN}}{V_{OUT}} \quad (35)$$

Where V_{VIN} is the working voltage of VIN pin (10V~11V is recommended).

(f) Select an appropriate wire diameter

With $I_{P_RMS_MAX}$ and $I_{S_RMS_MAX}$, select appropriate wire to make sure the current density ranges from 4A/mm² to 10A/mm².

(g) If the winding area of the core and bobbin is not enough, reselect the core style, go to (a) and redesign the transformer until the ideal transformer is achieved.

Output capacitor C_{OUT}

Preset the output current ripple ΔI_{OUT} . C_{OUT} is induced by

$$C_{OUT} = \frac{\sqrt{\left(\frac{2I_{OUT}}{\Delta I_{OUT}}\right)^2 - 1}}{4\pi f_{AC} R_{LED}} \quad (36)$$

Where I_{OUT} is the rated output current; ΔI_{OUT} is the demanded current ripple; f_{AC} is the input AC supply frequency; R_{LED} is the equivalent series resistor of the LED load.

RCD snubber for MOSFET

The power loss of the snubber P_{RCD} is evaluated first

$$P_{RCD} = \frac{N_{PS} \times (V_{OUT} + V_{D_F}) + \Delta V_S}{\Delta V_S} \times \frac{L_K}{L_M} \times P_{OUT} \quad (37)$$

Where N_{PS} is the turns ratio of the Flyback transformer; V_{OUT} is the output voltage; V_{D_F} is the forward voltage of the power diode; ΔV_S is the overshoot voltage clamped by RCD snubber; L_K is the leakage inductor; L_M is the inductance of the Flyback transformer; P_{OUT} is the output power.

The R_{RCD} is related with the power loss:

$$R_{RCD} = \frac{(N_{PS} \times (V_{OUT} + V_{D_F}) + \Delta V_S)^2}{P_{RCD}} \quad (38)$$

The C_{RCD} is related with the voltage ripple of the snubber ΔV_{C_RCD} :

$$C_{RCD} = \frac{N_{PS} \times (V_{OUT} + V_{D_F}) + \Delta V_S}{R_{RCD} f_S \Delta V_{C_RCD}} \quad (39)$$

Layout

(a) To achieve better EMI performance and reduce line frequency ripples, the output of the bridge rectifier should be connected to the BUS line capacitor first, then to the switching circuit.

(b) The circuit loop of all switching circuit should be kept small: primary power loop, secondary loop and auxiliary power loop.

(c) The connection of primary ground is recommended as:

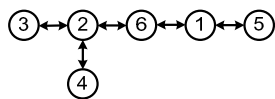

Ground ①: ground of BUS line capacitor
 Ground ②: ground of bias supply capacitor
 Ground ③: ground node of auxiliary winding

Ground ④: ground of signal trace

Ground ⑤: primary ground node of Y capacitor

Ground ⑥: ground node of current sample resistor.

(d) bias supply trace should be connected to the bias supply capacitor first instead of GND pin. The bias supply capacitor should be put beside the IC.

(e) Loop of 'Source pin – current sample resistor – GND pin' should be kept as small as possible.

(f) The resistor divider connected to ZCS pin is recommended to be put beside the IC.

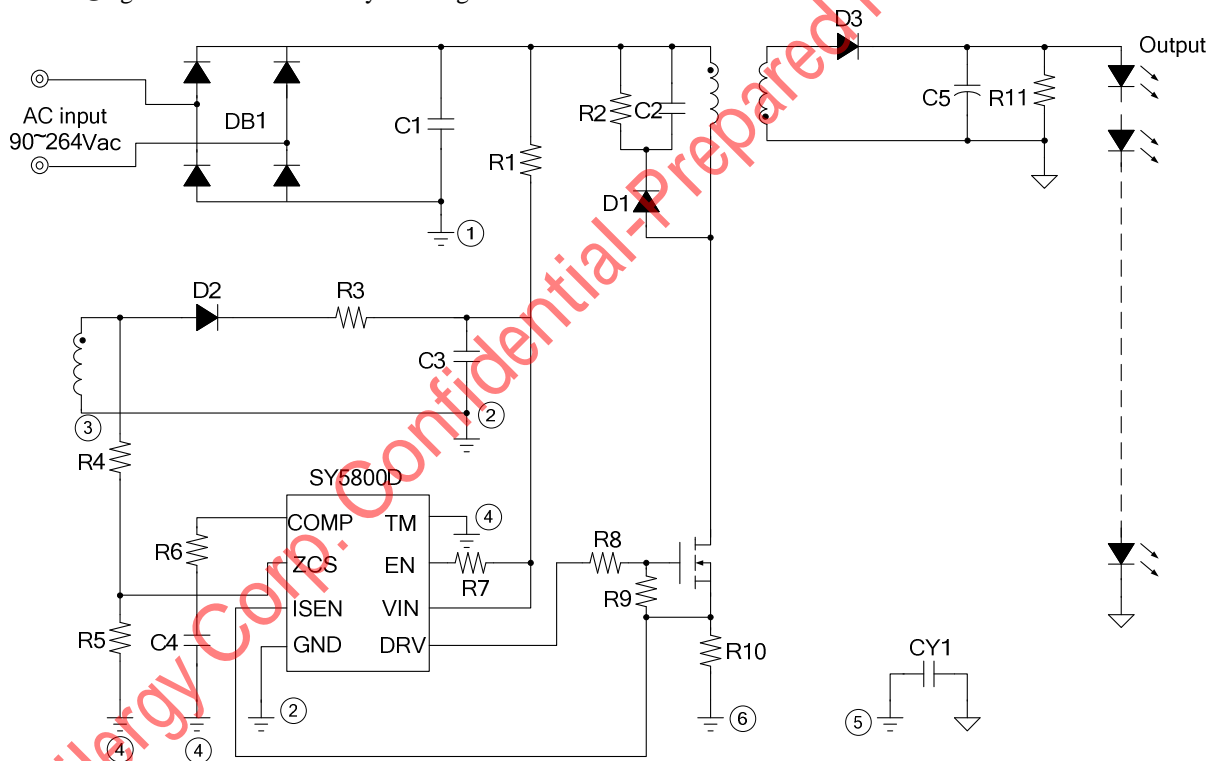

Design Example

A design example of typical application is shown below step by step.

#1. Identify design specification

| Design Specification | | | |
|----------------------|----------|-----------|-----|
| $V_{AC(RMS)}$ | 90V~264V | V_{OUT} | 38V |
| I_{OUT} | 320mA | η | 87% |

#2. Transformer design (N_{PS} , L_M)

Refer to Power Device Design

| Conditions | | | |
|---------------|-------|--------------------|-------|
| V_{AC_MIN} | 90V | V_{AC_MAX} | 264V |
| ΔV_S | 50V | $V_{MOS_ (BR)DS}$ | 600V |
| P_{OUT} | 12W | $V_{D,F}$ | 1V |
| C_{Drain} | 100pF | f_{S_MIN} | 75kHz |

(a) Compute turns ratio N_{PS} first

$$N_{PS} \leq \frac{V_{MOS_ (BR)DS} \times 90\% - \sqrt{2} V_{AC_MAX} - \Delta V_S}{V_{OUT} + V_{D,F}}$$

$$= \frac{600V \times 0.9 - \sqrt{2} \times 264V - 50V}{38V + 1V}$$

$$= 2.99$$

N_{PS} is set to

$$N_{PS} = 2.67$$

(b) f_{S_MIN} is preset

$$f_{S_MIN} = 75kHz$$

(c) Compute the switching period t_s and ON time t_1 at the peak of input voltage.

$$t_s = \frac{1}{f_{S_MIN}} = 13.3\mu s$$

$$t_1 = \frac{t_s \times N_{PS} \times (V_{OUT} + V_{D,F})}{\sqrt{2} V_{AC_MIN} + N_{PS} \times (V_{OUT} + V_{D,F})}$$

$$= \frac{13.3\mu s \times 2.67 \times (38V + 1V)}{\sqrt{2} \times 90V + (38V + 1V)}$$

$$= 6\mu s$$

(d) Compute the inductance L_M

$$\begin{aligned} L_M &= \frac{V_{AC_MIN}^2 \times t_1^2 \times \eta}{2P_{OUT} \times t_s} \\ &= \frac{90V^2 \times 6\mu s^2 \times 0.87}{2 \times 12W \times 13.3\mu s} \\ &= 780\mu H \end{aligned}$$

Set

$$L_M = 750\mu H$$

(e) Compute the quasi-resonant time t_3

$$\begin{aligned} t_3 &= \pi \times \sqrt{L_M \times C_{Drain}} \\ &= \pi \times \sqrt{750\mu H \times 100pF} \\ &= 860ns \end{aligned}$$

(f) Compute primary maximum peak current $I_{P_PK_MAX}$

$$\begin{aligned} I_{P_PK_MAX} &= \frac{2P_{OUT} \times \left[\frac{L_M}{\sqrt{2}V_{AC_MIN}} + \frac{L_M}{N_{PS} \times (V_{OUT} + V_{D,F})} \right]}{L_M \times \eta} \\ &+ \frac{\sqrt{4P_{OUT}^2 \times \left[\frac{L_M}{\sqrt{2}V_{AC_MIN}} + \frac{L_M}{N_{PS} \times (V_{OUT} + V_{D,F})} \right]^2 + 4L_M \times \eta \times P_{OUT} \times t_3}}{L_M \times \eta} \\ &= 1.038A \end{aligned}$$

Adjust switching period t_s and ON time t_1 to t'_s and t'_1 .

$$\begin{aligned} t'_s &= \frac{\eta \times L_M \times I_{P_PK_MAX}^2}{4P_{OUT}} \\ &= \frac{0.87 \times 750\mu H \times 1.038A^2}{4 \times 12W} \\ &= 14.45\mu s \end{aligned}$$

$$\begin{aligned} t'_1 &= \frac{L_M \times I_{P_PK_MAX}}{\sqrt{2}V_{AC_MIN}} \\ &= \frac{750\mu H \times 1.038A}{\sqrt{2} \times 90V} \\ &= 6.12\mu s \end{aligned}$$

Compute primary maximum RMS current $I_{P_RMS_MAX}$

$$I_{P_RMS_MAX} \approx \sqrt{\frac{t'_1}{6t'_s}} \times I_{P_PK_MAX} = \sqrt{\frac{6.12\mu s}{6 \times 14.45\mu s}} \times 1.038A = 0.289A$$

(g) Compute secondary maximum peak current and the maximum RMS current.

$$I_{S_PK_MAX} = N_{PS} \times I_{P_PK_MAX} = 2.67 \times 1.038A = 2.77A$$

$$t'_2 = t'_s - t_1 - t_3 = 14.45\mu s - 6.12\mu s - 0.86\mu s = 7.47\mu s$$

$$I_{S_RMS_MAX} \approx \sqrt{\frac{t'_2}{6t'_s}} \times I_{S_PK_MAX} = \sqrt{\frac{7.47\mu s}{6 \times 14.45\mu s}} \times 2.77A = 0.81A$$

#3. Select power MOSFET and secondary power diode

Refer to Power Device Design

| Known conditions at this step | | | |
|-------------------------------|------|------------|------|
| V_{AC_MAX} | 264V | N_{PS} | 2.67 |
| V_{OUT} | 36V | V_{D_F} | 1V |
| ΔV_S | 50V | η | 87% |

(a) Compute the voltage and the current stress of MOSFET:

$$\begin{aligned} V_{MOS_DS_MAX} &= \sqrt{2}V_{AC_MAX} + N_{PS} \times (V_{OUT} + V_{D_F}) + \Delta V_S \\ &= \sqrt{2} \times 264V + 2.67 \times (38V + 1V) + 50V \\ &= 527V \end{aligned}$$

$$I_{MOS_PK_MAX} = I_{P_PK_MAX} = 1.038A$$

$$I_{MOS_RMS_MAX} = I_{P_RMS_MAX} = 0.289A$$

(b) Compute the voltage and the current stress of secondary power diode

$$\begin{aligned} V_{D_R_MAX} &= \frac{\sqrt{2}V_{AC_MAX}}{N_{PS}} + V_{OUT} \\ &= \frac{\sqrt{2} \times 264V}{2.67} + 38V \\ &= 178V \end{aligned}$$

$$I_{D_PK_MAX} = N_{PS} \times I_{P_PK_MAX} = 2.67 \times 1.038A = 2.77A$$

$$I_{D_AVG} = I_{OUT} = 0.32A$$

#4. Select the output capacitor C_{OUT}

Refer to Power Device Design

| | | | |
|------------|-------|------------------|-----------------------|
| Conditions | | | |
| I_{OUT} | 320mA | ΔI_{OUT} | $0.3I_{OUT}$ |
| f_{AC} | 50Hz | R_{LED} | $12 \times 1.6\Omega$ |

The output capacitor is

$$C_{OUT} = \frac{\sqrt{\left(\frac{2I_{OUT}}{\Delta I_{OUT}}\right)^2 - 1}}{4\pi f_{AC} R_{LED}}$$

$$= \frac{\sqrt{\left(\frac{2 \times 0.32A}{0.3 \times 0.32A}\right)^2 - 1}}{4\pi \times 50Hz \times 12 \times 1.6\Omega}$$

$$= 546\mu F$$

#5. Design RCD snubber

Refer to Power Device Design

| | | | |
|------------|------|--------------|-----|
| Conditions | | | |
| V_{OUT} | 38V | ΔV_S | 50V |
| N_{PS} | 2.67 | L_K/L_M | 1% |
| P_{OUT} | 12W | | |

The power loss of the snubber is

$$P_{RCD} = \frac{N_{PS} \times (V_{OUT} + V_{D,F}) + \Delta V_S}{\Delta V_S} \times \frac{L_K}{L_M} \times P_{OUT}$$

$$= \frac{2.67 \times (38V + 1V) + 50V}{50V} \times 0.01 \times 12W$$

$$= 0.37W$$

The resistor of the snubber is

$$R_{RCD} = \frac{(N_{PS} \times (V_{OUT} + V_{D,F}) + \Delta V_S)^2}{P_{RCD}}$$

$$= \frac{(2.67 \times (38V + 1V) + 50V)^2}{0.37W}$$

$$= 64k\Omega$$

The capacitor of the snubber is

$$C_{RCD} = \frac{N_{PS} \times (V_{OUT} + V_{D,F}) + \Delta V_S}{R_{RCD} f_s \Delta V_{C,RCD}}$$

$$= \frac{2.67 \times (38V + 1V) + 50V}{64k\Omega \times 100kHz \times 25V}$$

$$= 1nF$$

#6. Set VIN pin

Refer to Start up

| Conditions | | | |
|---------------|---------------------|---------------|----------------------------|
| $V_{BUS-MIN}$ | $90V \times 1.414$ | $V_{BUS-MAX}$ | $264V \times 1.414$ |
| I_{ST} | $15\mu A$ (typical) | V_{IN-ON} | $16V$ (typical) |
| $I_{VIN-OVP}$ | $2mA$ (typical) | t_{ST} | $500ms$ (designed by user) |

(a) R_{ST} is preset

$$R_{ST} < \frac{V_{BUS}}{I_{ST}} = \frac{90V \times 1.414}{15\mu A} = 8.48M\Omega ,$$

$$R_{ST} > \frac{V_{BUS}}{I_{VIN-OVP}} = \frac{264V \times 1.414}{2mA} = 186k\Omega$$

Set R_{ST}

$$R_{ST} = 250k\Omega \times 3 = 750k\Omega$$

(b) Design C_{VIN}

$$C_{VIN} = \frac{(\frac{V_{BUS}}{R_{ST}} - I_{ST}) \times t_{ST}}{V_{VIN-ON}}$$

$$= \frac{(\frac{90V \times 1.414}{750k\Omega} - 15\mu A) \times 500ms}{16V}$$

$$= 4.83\mu F$$

Set C_{VIN}

$$C_{VIN} = 20\mu F$$

#7 Set COMP pin

Refer to **Internal pre-charge design for quick start up**

| Parameters designed | | | |
|---------------------|-------------|---------------|---------|
| R_{COMP} | 500Ω | $V_{COMP,IC}$ | $450mV$ |
| C_{COMP1} | $2\mu F$ | C_{COMP2} | $100pF$ |

#8 Set current sense resistor to achieve ideal output current

Refer to **Primary-side constant-current control**

| Known conditions at this step | | | |
|-------------------------------|-------|-----------|-------|
| k | 0.167 | N_{PS} | 2.67 |
| V_{REF} | 0.3V | I_{OUT} | 0.32A |

The current sense resistor is

$$R_S = \frac{k \times V_{REF} \times N_{PS}}{I_{OUT}}$$

$$= \frac{0.167 \times 0.3V \times 2.67}{0.32A}$$

$$= 0.4\Omega$$

#9 set ZCS pin

Refer to **Line regulation modification** and **Over Voltage Protection (OVP) & Open Loop Protection (OLP)**

First identify R_{ZCSU} need for line regulation.

| Known conditions at this step | | | |
|-------------------------------|---------------|--|--|
| k 2 | 68 | | |
| Parameters Designed | | | |
| R_{ZCSU} | 100k Ω | | |

Then compute R_{ZCSD}

| Conditions | | | |
|---------------------|---------------|-----------|-----|
| V_{ZCS_OVP} | 1.31V | V_{OVP} | 55V |
| V_{OUT} | 38V | | |
| Parameters designed | | | |
| R_{ZCSU} | 100k Ω | | |
| N_S | 21 | N_{AUX} | 5 |

$$R_{ZCSD} < \frac{\frac{V_{ZCS_OVP}}{V_{OUT}} \times \frac{N_S}{N_{AUX}} \times R_{ZCSU}}{1 - \frac{V_{ZCS_OVP}}{V_{OUT}} \times \frac{N_S}{N_{AUX}}}$$

$$= \frac{\frac{1.31V}{38V} \times \frac{21}{6} \times 100k\Omega}{1 - \frac{1.31V}{38V} \times \frac{21}{6}}$$

$$= 18.04k\Omega$$

$$R_{ZCSD} \geq \frac{\frac{V_{ZCS_OVP}}{V_{OVP}} \times \frac{N_s}{N_{AUX}}}{1 - \frac{V_{ZCS_OVP}}{V_{OVP}} \times \frac{N_s}{N_{AUX}}} \times R_{ZCSU}$$

$$= \frac{\frac{1.31V}{55V} \times \frac{21}{5}}{1 - \frac{1.31V}{55V} \times \frac{21}{5}} \times 100k\Omega$$

$$= 11.11k\Omega$$

R_{ZCSD} is set to

$$R_{ZCSD} = 11.6k\Omega$$

#10 final result

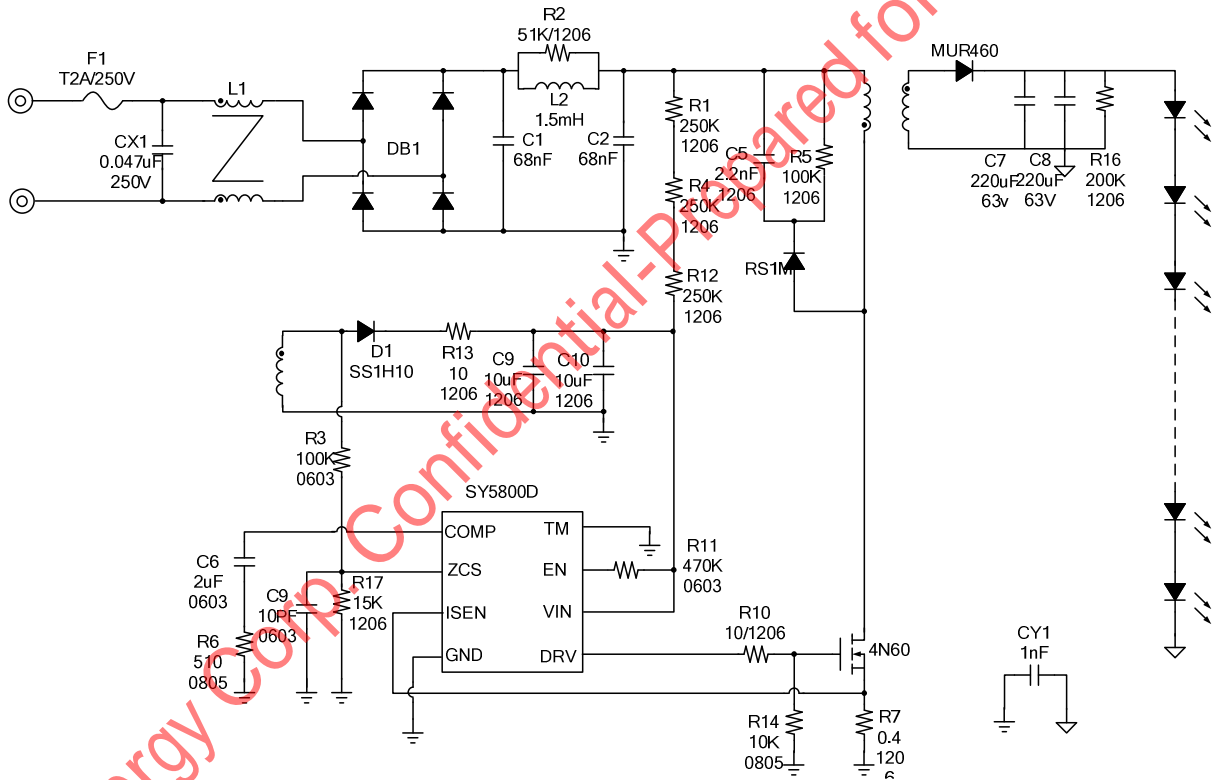

SO8 Package Outline & PCB Layout Design

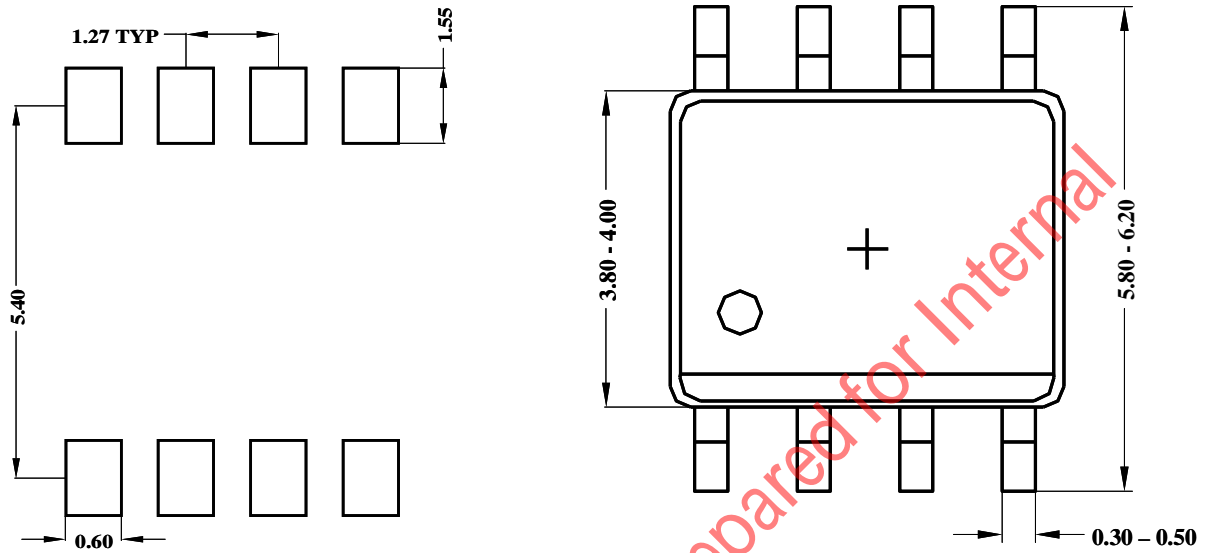

Recommended Pad Layout

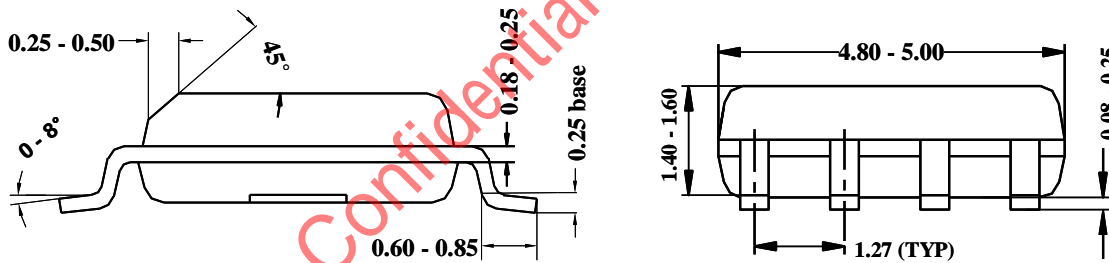

**Notes: All dimensions are in millimeters.
All dimensions don't include mold flash & metal burr.**

单击下面可查看定价，库存，交付和生命周期等信息

[>>SILERGY\(矽力杰\)](#)