

3SM102ETT13C MEMS Microphone

Product Description

The 3SM102ETT13C brings excellent performance on the applications of **ANC headphone, TWS headset, Beam-forming device** and **Voice Recognition device** by the unique features of tiny package size, flat frequency response, uniform sensitivity and phase coherence.

Features

- High performance single chip analog CMOS MEMS microphone
- High stability - no risk of membrane aging
- Suitable for automatic pick-and-place handler and SMT process
- Analog microphone with a footprint of only 4.32mm²
- Miniature dimension 2.40mm x 1.80mm x 1.10mm
- Low current consumption 140uA
- RoHS/Green Compliant
- Sensitivity deviation within ± 1 dB
- Package type : LGA 4-pin

Applications

- ANC Headsets
- TWS Headsets
- Wearable Devices
- IoT Devices

Table of Contents

Product Description	P.1
Features	P.1
Applications	P.1
Table of Contents.....	P.2
Functional Block Diagram	P.3
Acoustical and Electrical Characteristics.....	P.3
Temperature Range	P.4
Reliability Qualifications	P.4
Reflow Profile	P.5
Pin Definition and Function	P.6
Frequency Response	P.7
PCB Land Pattern Layout	P.8
Application Circuit	P.9
Handling Instructions	P.10
Dimensions	P.11
Package Information.....	P.12
Revision History	P.14

Functional Block Diagram

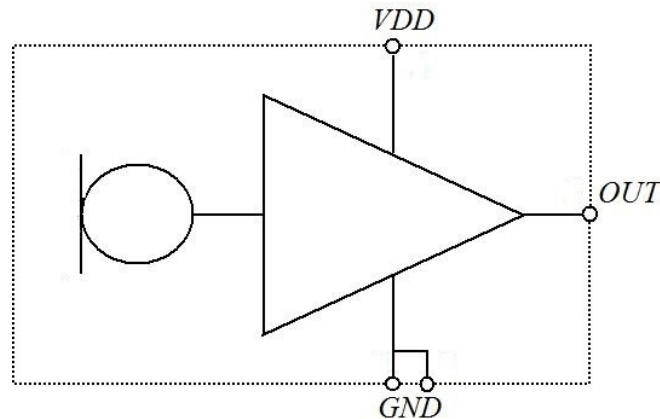

Acoustical and Electrical Characteristics

Table 1 Typical test conditions are $T_A = 23\text{ }^\circ\text{C}$, $V_{DD} = 2.1\text{ V}$ and $R.H. = 50\%$ measured in a pressure chamber test setup. All voltages refer to GND node

Parameters	Symbol	Min.	Typ.	Max.	Unit	Test Conditions
Acoustic						
Sensitivity	S	-33	-32	-31	dBV/Pa	1kHz, 94dB SPL
Signal to Noise Ratio	S/N		59		dB	A-weighted
Equivalent Noise Level	ENL		35		dB	A-weighted
Total Harmonic Distortion	THD		0.2		%	94dB SPL
Acoustic Overload Point	AOP		120		dB SPL	
Electrical						
Supply Voltage	Vdd	1.2		3.6	V	
Current Consumption	I _{sb}		140		μA	
Power Supply Rejection	PSR+N		-82		dB	217Hz, 100 mV peak to peak square wave superimposed on Vcc 2.1V
Power Supply Rejection Ratio	PSRR		65		dB	217Hz, 200 mV peak to peak sine wave superimposed on Vcc 2.1V
Output Impedance	Z _{out}			200	Ω	
Output DC Offset			0.93		V	

Temperature Range

Table 2

Storage Temperature	T _{STG}	-40°C ~ 100°C
Operating Temperature Range	T _A	-40°C ~ 85°C

Reliability Qualifications

Table 3

Test Item	Description
High Temperature Storage	Storage at 105°C for 1,000 hours IEC 60068-2-2 Test Ba
Low Temperature Storage	Storage at -40°C for 1,000 hours IEC 60068-2-1 Test Aa
High Temperature Operation Bias	Under Bias at 105°C for , 1,000 hours IEC 60068-2-2 Test Ba
Low Temperature Operation Bias	Under Bias at -40°C for , 1,000 hours IEC 60068-2-1 Test Aa
Temperature Humidity Bias	Under Bias at 85°C/85%RH for 1,000 hours JESD22-A101-B
Thermal Shock	Thermal Shock 100 cycles from -40°C~125°C, 100 cycles IEC 60068-2-14
Reflow	5 reflow cycles with peak 260°C J-STD-020D
Vibration	4 cycles lasting 12 minutes from 20 to 2,000Hz in X, Y and Z with peak acceleration of 20G MIL 883E, Method 2007.2, A
Shock	3 pulses 10,000G in X,Y and Z IEC 60068-2-27, Test Ea
ESD	HBM: 3KV, MM:300V, CDM:500V JESD22-A114(HBM); JESD22-A115(MM)

Reflow Profile

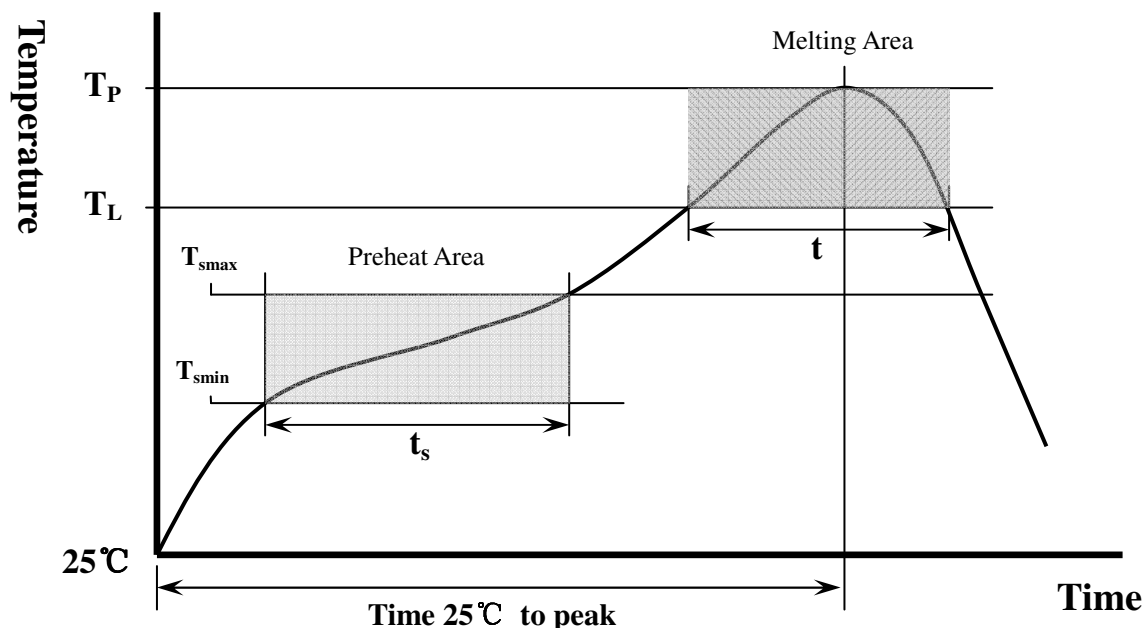

Table 4. Recommended Reflow Profile Limits

Profile Feature	Pb-free
Preheat	
Minimum temperature (T_{smin})	150 °C
Maximum temperature (T_{smax})	200 °C
Time (t_s)	60~180 sec
Average Ramp up rate (T_{smax} to T_P)	3 °C/sec
Melting area	
Melting temperature (T_L)	217 °C
Time maintained above melting (t)	60~150 sec
Peak Temperature (T_P)	260 °C
Time within 5°C of actual peak temperature	20~40 sec
Ramp down rate	6 °C/sec maximum
Time 25°C to peak temperature	8 minute maximum

Pin Definition and Function

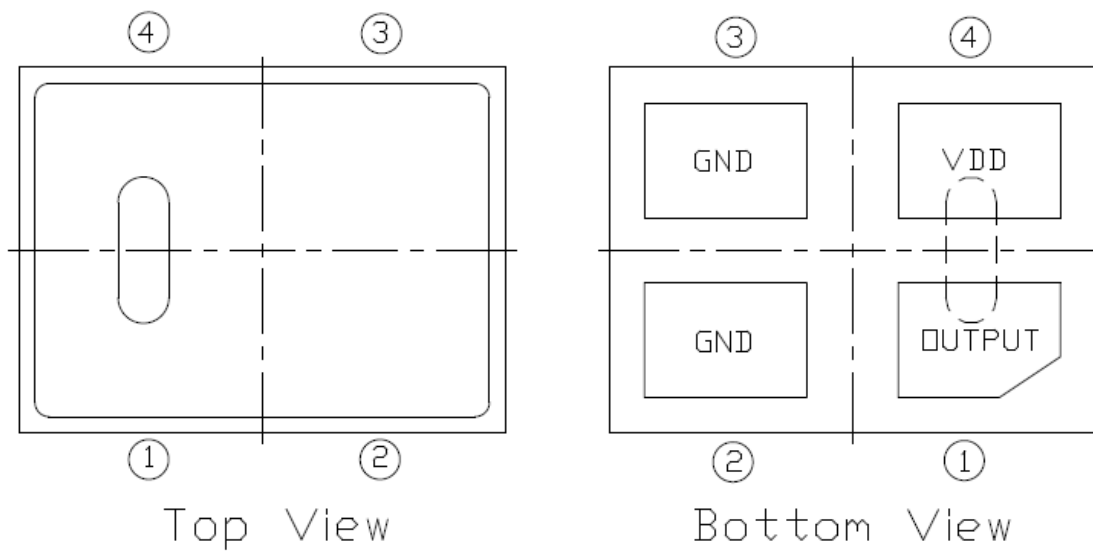
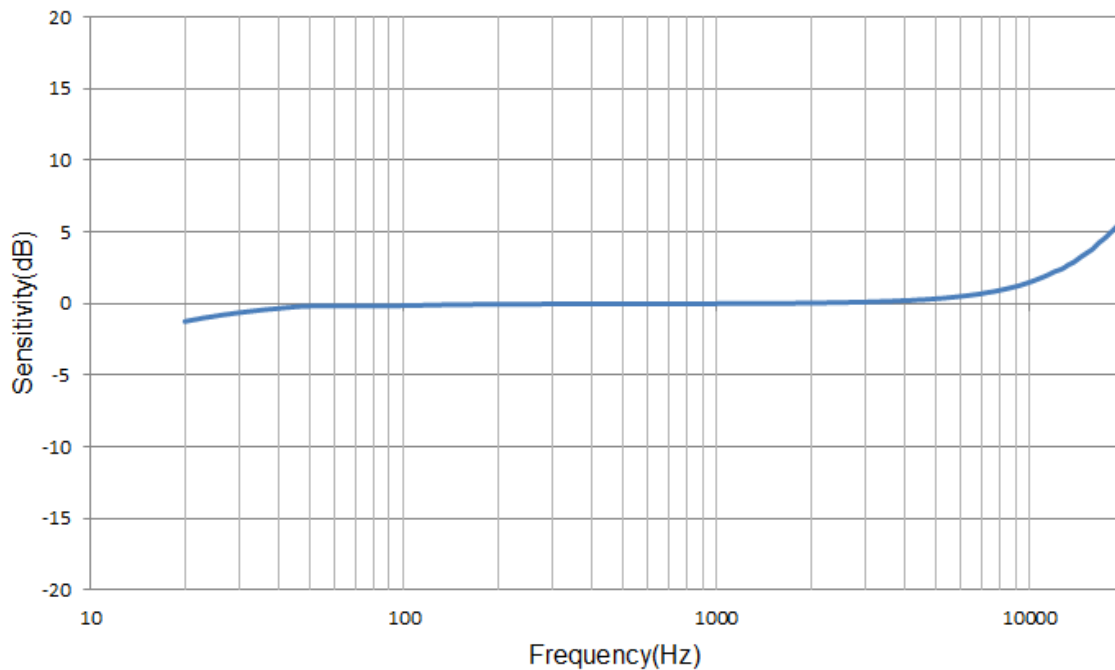

Table 5

Pin #	Symbol	Function
1	OUTPUT	Analog signal output
2	GND	Ground
3	GND	Ground
4	VDD	Power supply

Frequency Response



Typical frequency response normalized to 1KHz (Measured)

PCB Land Pattern Layout

Recommended Land Pattern

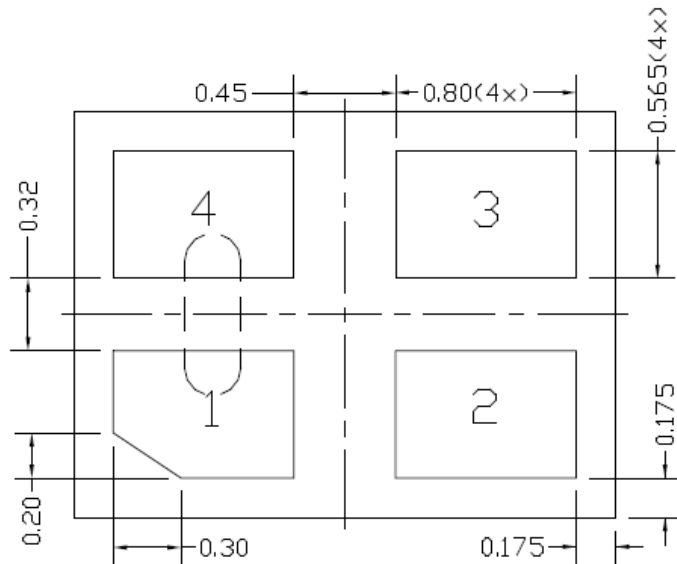

Application Circuit

Typical Application:

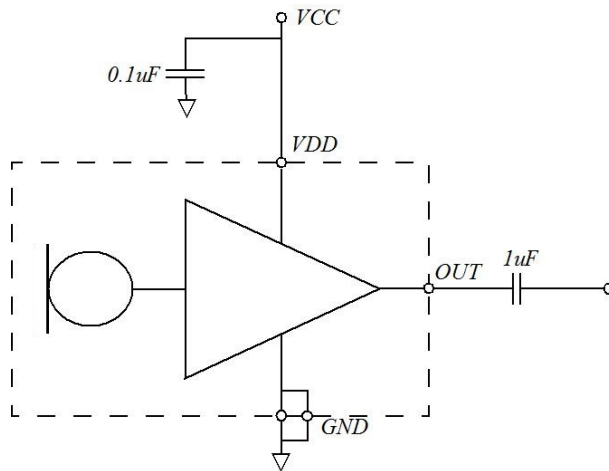

Handling Instructions

The MEMS microphone can be handled using standard pick-and-place and chip-shooting equipment. Care should be taken to avoid damage to the MEMS microphone structure as follows:

- Do not apply vacuum nozzle over the acoustic port (AP) of the microphone to avoid damage to the device.
- Do not blow air directly into acoustic port. If air gun cleaning is required, the minimum distance is 10cm and the maximum air blow pressure is 30psi.
- Brushing the board with/without solvents may damage the device.
- Do not use excessive force to place the microphone on the PCB.
- In case of manual handling, it should be handled with plastic tweezers to avoid damage to the device.
- Do not open and remove IC from packaging until devices are ready to be mounted.
- Suggest PCB depaneling be done with depaneling cutter/router, or manually de-panel PCB with care and without any contact of MEMS Microphone.

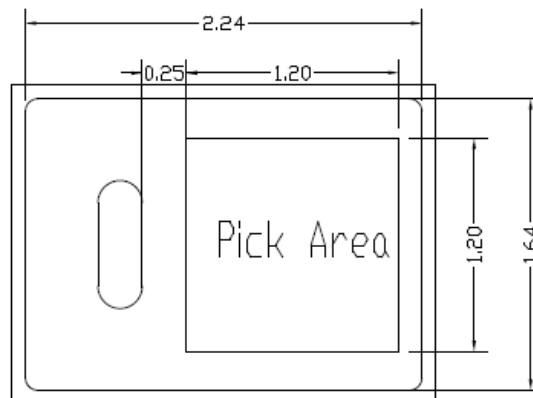

Dimensions

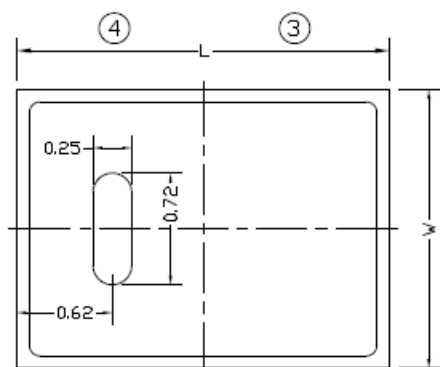

Top View

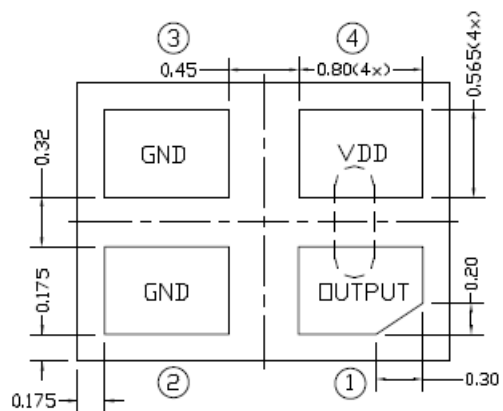
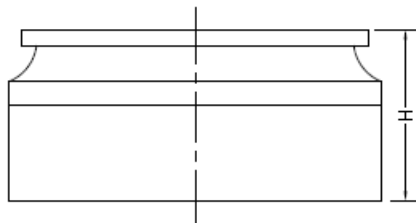

Bottom View

Unit: mm

Table 6(Top View)

Item	Dimension	Tolerance
Length (L)	2.40 mm	±0.10 mm
Width (W)	1.80 mm	±0.10 mm
Height (H)	1.10 mm	±0.10 mm

Package Information

Carrier Tape:

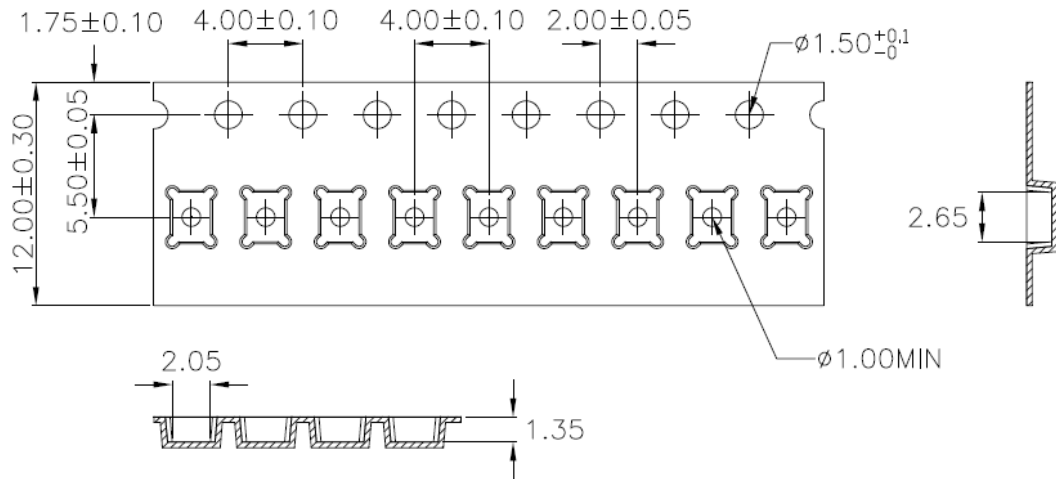

1. 10 sprocket hole pitch cumulative tolerance $\neq 0.20$.
2. Carrier camber is within 1 mm in 250 mm.
3. Material : Black Conductive Polystyrene Alloy.
4. All dimensions meet EIA-481-D requirements.
5. Thickness : 0.30 ± 0.05 mm.

Unit: mm

Note:

1. MSL(Moisture sensitivity level) Class 1.

13" Tape Reel :

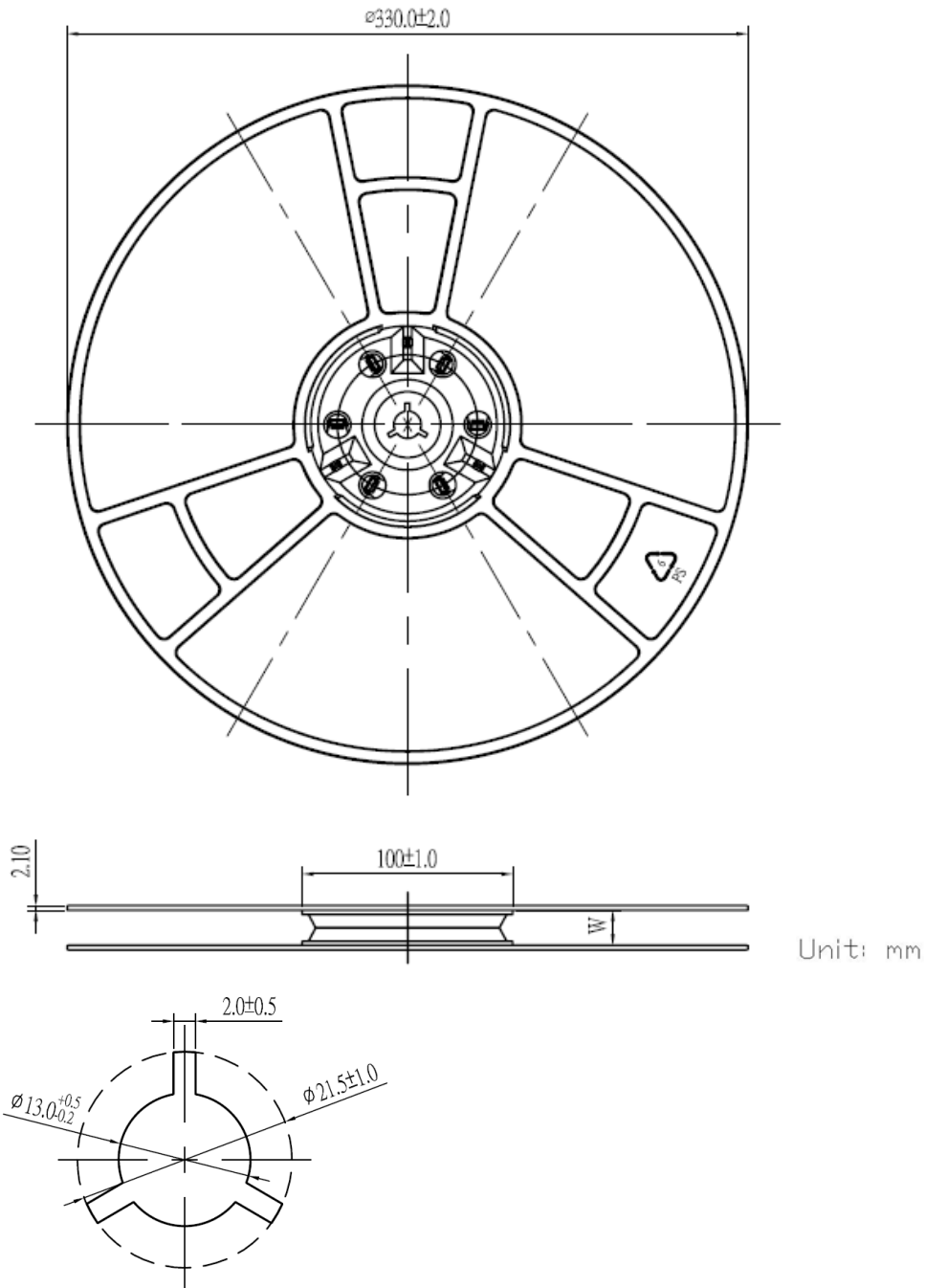

Revision History

Revision	Date	Description
1.0	2018/08/07	Formal release
1.1	2018/09/21	Modify “Product Description”
1.2	2019/01/10	Modify “Frequency Response”
1.3	2019/01/14	Modify “Frequency Response”

单击下面可查看定价，库存，交付和生命周期等信息

[>>3S\(Solid state system\)\(鑫创科技\)](#)