

IRAUDAMP12

130W/4Ω x 2 Channel Class D Audio Power Amplifier Using the IR4301

By

Jun Honda, Liwei Zheng

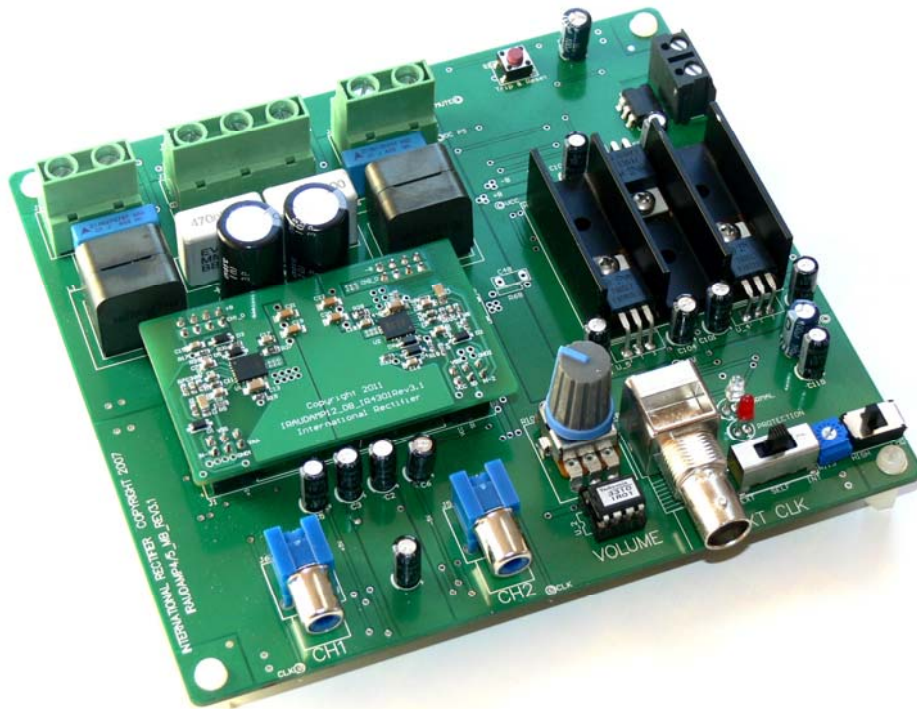

CAUTION:

International Rectifier suggests the following guidelines for safe operation and handling of IRAUDAMP12 Demo board;

- Always wear safety glasses whenever operating Demo Board
- Avoid physical contact with exposed metal surfaces when operating Demo Board
- Turn off Demo Board when placing or removing measurement probes

TABLE OF CONTENTS	PAGE
INTRODUCTION.....	3
SPECIFICATIONS	3
CONNECTOR DESCRIPTION.....	5
TEST PROCEDURES.....	6
PERFORMANCE AND TEST GRAPHS	7
THERMAL INFORMATION	13
SCHEMATIC.....	18
BILL OF MATERIALS	20
PCB SPECIFICATIONS.....	22
REVISION CHANGES DESCRIPTIONS	26

Introduction

The IRAUDAMP12 reference design is a two-channel, 130W/ch (4Ω/±31V; no heatsink)/ 160W/ch (4Ω/±34V; *with heatsink) half-bridge Class D audio power amplifier. This reference design demonstrates how to use the IR4301 IC, implement protection circuits, and design an optimum PCB layout using PowIRaudio integrated Class D IC. This reference design does not require heatsink or fan cooling for normal operation (one-eighth of continuous rated power). The reference design provides all the required housekeeping power supplies for ease of use. The two-channel design is scalable for power and the number of channels.

Applications

- AV receivers
- Home theater systems
- Mini component stereos
- Powered speakers
- Sub-woofers
- Musical Instrument amplifiers
- Car audio amplifiers

Features

Output Power:	130W x 2 channels (10%THD+N 4Ω load; no heatsink), 160W x 2 channels (10%THD+N 4Ω load; *with heatsink),
Multiple Protection Features:	Over-current protection (OCP), high side and low side Over-voltage protection (OVP), Under-voltage protection (UVP), high side and low side DC-protection (DCP), Over-temperature protection (OTP)
PWM Modulator:	Self-oscillating half-bridge topology with optional clock synchronization

Specifications

General Test Conditions (unless otherwise noted)	Notes / Conditions	
Supply Voltages	±15V~±31V	Bipolar power supply; without heatsink
	±15V~±34V	Bipolar power supply; *with heatsink
Load Impedance	4-2Ω	Resistive load
Self-Oscillating Frequency	400kHz	No input signal, Adjustable
Gain Setting	26dB	1Vrms input yields rated power

Electrical Data	Typical	Notes / Conditions
IR Devices Used	IR4301 PowIRaudio integrated Class D IC	
Modulator	Self-oscillating, second order sigma-delta modulation, analog input	
Output Power CH1-2: (1% THD+N)	100W	1kHz, 4Ω load, without heatsink
	130W	1kHz, 4Ω load, *with heatsink
	80W	1kHz, 3Ω load, without heatsink
	95W	1kHz, 3Ω load, *with heatsink
	55W	1kHz, 2Ω load, without heatsink
	70W	1kHz, 2Ω load, *with heatsink

Output Power CH1-2: (10% THD+N)	130W	1kHz, 4Ω load, without heatsink
	160W	1kHz, 4Ω load, *with heatsink
	100W	1kHz, 3Ω load, without heatsink
	120W	1kHz, 3Ω load, *with heatsink
	70W	1kHz, 2Ω load, without heatsink
	90W	1kHz, 2Ω load, *with heatsink
Rated Load Impedance	4-2Ω	Resistive load
Idling Supply Current	±80mA	No input signal
Total Idle Power Consumption	4W	No input signal
Distortion	0.02%	THD+N @ 50W, 4Ω
Residual Noise	250μV	IHF-A weighted, AES-17 filter
Channel Efficiency	96%	Single-channel driven, 130W/*160W(* with heatsink), Class D stage

*Tested with heatsink from Digikey, part#:294-1085-ND with thermal pad BER161-ND

Connection Setup

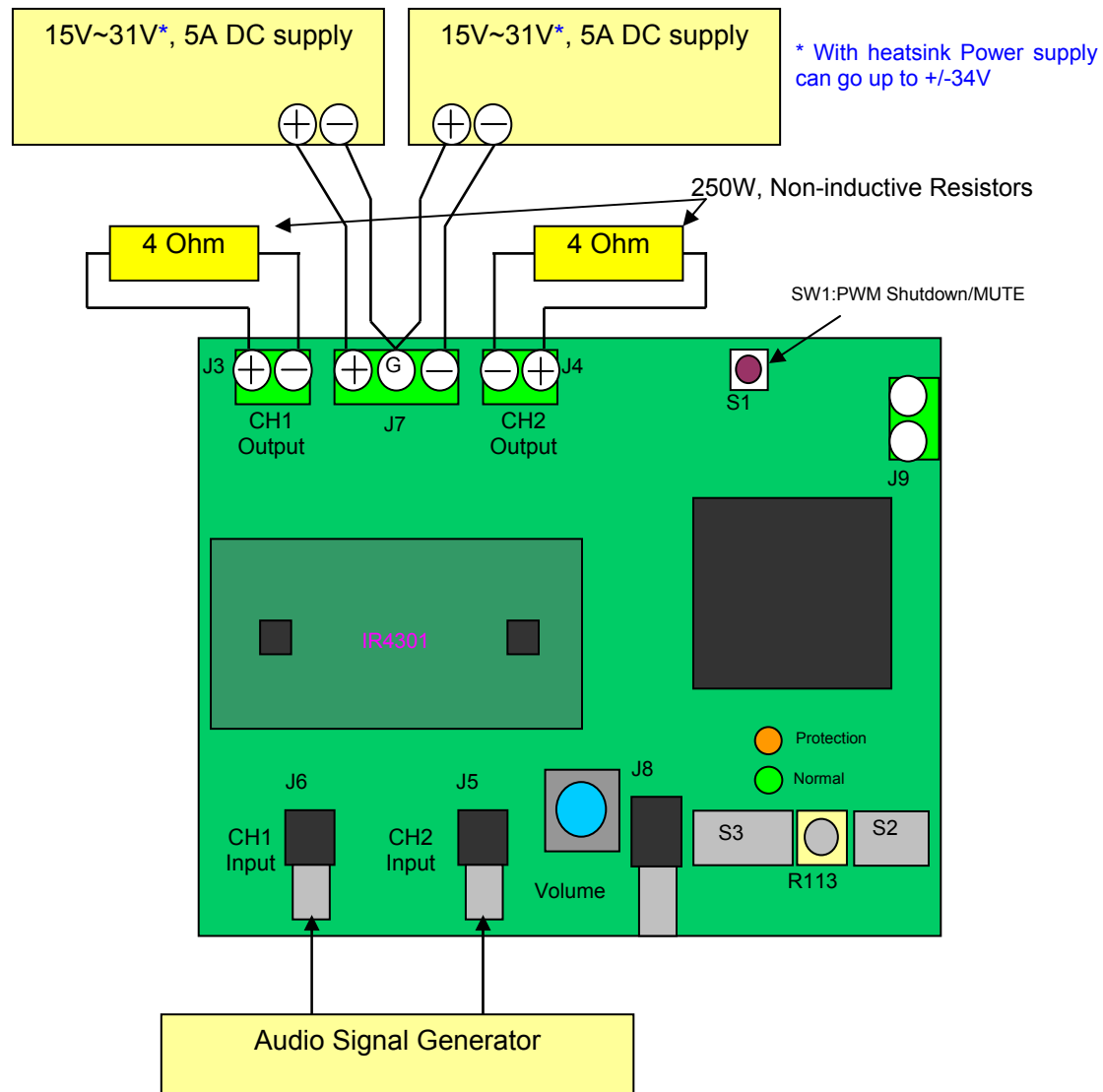

Figure 1 Typical Test Setup

Connector Description

CH1 IN	J6	Analog input for CH1
CH2 IN	J5	Analog input for CH2
POWER	J7	Positive and negative supply (+B / -B)
CH1 OUT	J3	Output for CH1
CH2 OUT	J4	Output for CH2
EXT CLK	J8	External clock sync
DCP OUT	J9	DC protection relay output

Audio Precision-Setup

IRAUDAMP12 and Audio Precision shall be connected according to the Figure below:

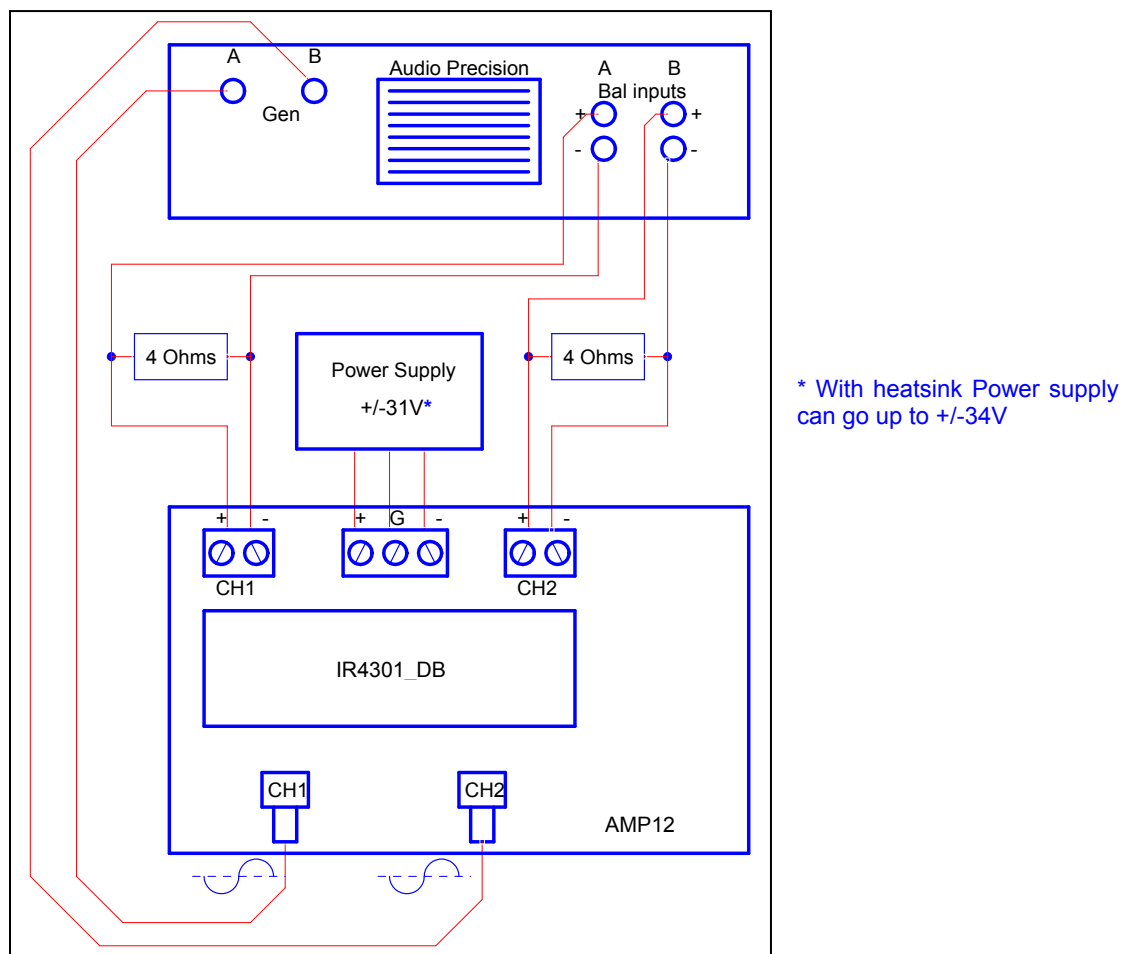

Figure 2

Test Procedures

Test Setup:

1. Connect 4 Ω -250 W dummy loads to output connectors (J3 and J4 as shown on Figure 1) and parallel it with input of Audio Precision analyzer (AP).
2. Connect Audio Signal Generator to J6 and J5 for CH1 and CH2 respectively (Ap).
3. Set up the dual power supply with voltages of $\pm 15V \sim \pm 31V$ (up to $\pm 34V$ with heatsink); set current limit to 5A.
4. Set switch S1 to middle position (self oscillating).
5. Set volume level knob R130 fully counter-clockwise (minimum volume).
6. Connect the dual power supply to J7. as shown on Figure 1

Power up:

7. Turn ON the dual power supply. The $\pm B$ supplies must be applied and removed at the same time.
8. Red LED (Protection) should turn on almost immediately and turn off after about 3s.
9. Green LED (Normal) then turns on after red LED is extinguished and should stay on.
10. Quiescent current for the positive supply should be 60mA \pm 10mA at +31V.
11. Quiescent current for the negative supply should be 80mA \pm 10mA at -31V.
12. Push S3 switch (Trip and Reset push-button) to restart the sequence of LEDs indicators, which should be the same as noted above in steps 9-10.

Functionality Audio Tests:

13. Apply 1V RMS at 1kHz sinusoidal signal from the Audio Signal Generator.
14. Turn control volume up (R130 clock-wise) to obtain an output reading of 250Watts.
15. For all subsequent tests as shown on the Audio Precision graphs below (Figure 3- Figure7), the measurements are taken across J3 and J4 with an AES-17 Filter. Observe that a 1 V_{RMS} input generates an output around THD+N=1% power level.
16. Sweep the audio signal voltage from 15 mV $_{RMS}$ to 1 V_{RMS} .
17. Monitor the output signals at J3/J4 with an oscilloscope. The waveform must be a non distorted sinusoidal signal with input signal below 1Vrms.

Performance and Test Graphs

Power vs THD+N

Test Conditions:

VBus = ± 31V
 Input Signal = 1 KHz
 Load Impedance = 4 ohms
 Set Gain = 1% clipping 100W

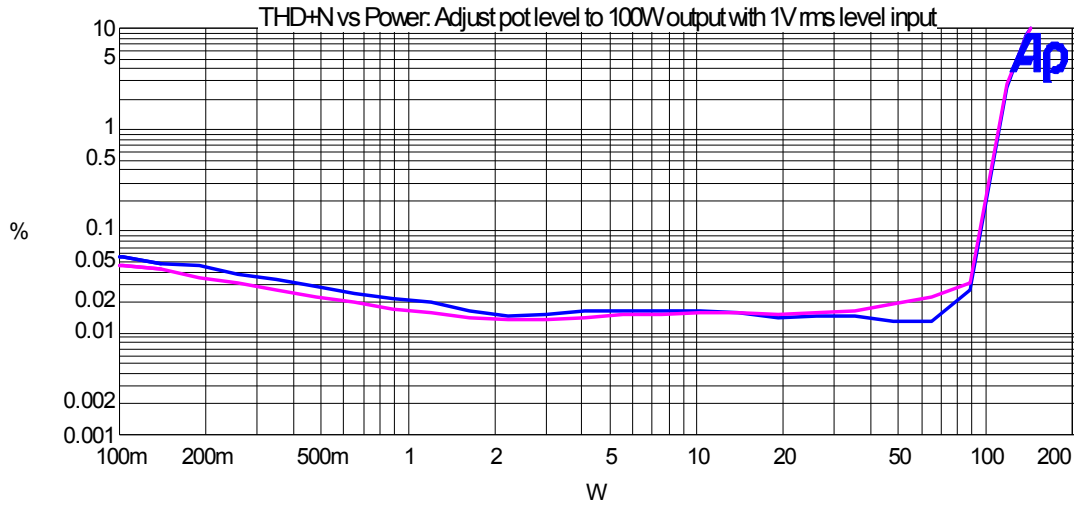

Sweep	Trace	Color	Line Style	Thick	Data	Axis	Comment
1	1	Blue	Solid	2	Anlr.THd+N Ratio	Left	CH1 - 4 Ohms
1	3	Magenta	Solid	2	Anlr.THd+N Ratio	Left	CH2 - 4 Ohms

Figure 3

Test Conditions:

VBus = ± 25V
 Input Signal = 1 KHz
 Load Impedance = 3 ohms
 Set Gain = 1% clipping 90W

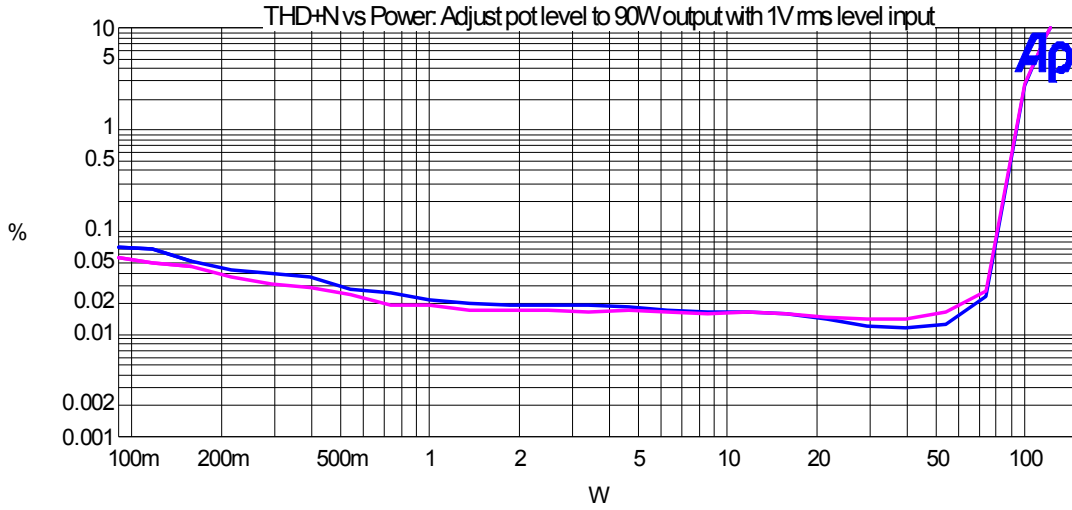

Sweep	Trace	Color	Line Style	Thick	Data	Axis	Comment
1	1	Blue	Solid	2	Anlr. THD+N Ratio	Left	CH1 - 3 Ohms
1	3	Magenta	Solid	2	Anlr. THD+N Ratio	Left	CH1 - 3 Ohms

Figure 4

Test Conditions:

VBus = ± 17V
 Input Signal = 1 KHz
 Load Impedance = 2 ohms
 Set Gain = 1% clipping 55W

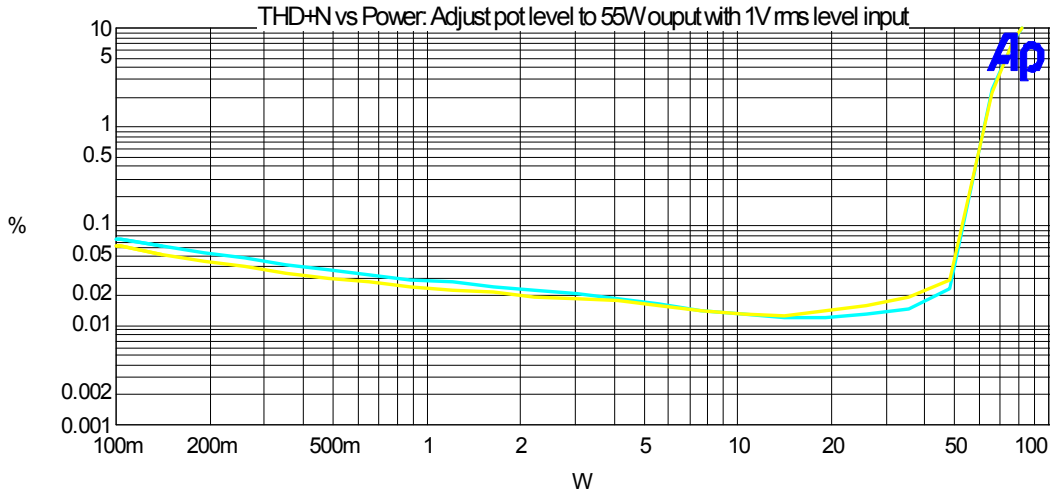

Sweep	Trace	Color	Line Style	Thick	Data	Axis	Comment
1	1	Cyan	Solid	2	Anlr. THD+N Ratio	Left	CH1 - 2 Ohms
1	3	Yellow	Solid	2	Anlr. THD+N Ratio	Left	CH2 - 2 Ohms

Figure 5

Power vs THD+N (with heatsink)

Test Conditions:

VBus = ± 34V
 Input Signal = 1 KHz
 Load Impedance = 4 ohms
 Set Gain = 1% clipping 130W

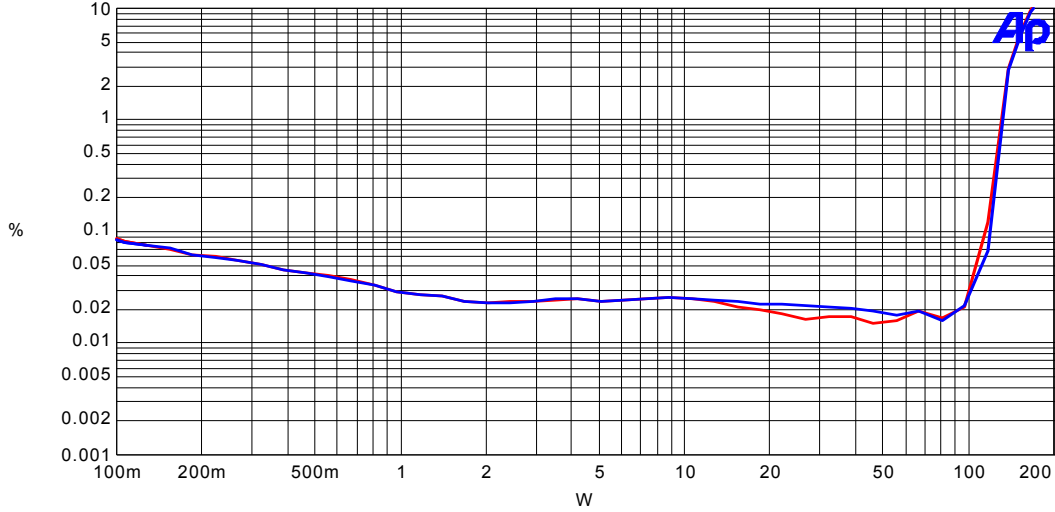

Sweep	Trace	Color	Line Style	Thick	Data	Axis	Comment
1	1	Red	Solid	2	S2.Anlr.THd+N Ratio	Left	CH1 4ohm 34V
1	3	Blue	Solid	2	S2.Anlr.THd+N Ratio	Left	CH2 4ohm 34V

Figure 6

Test Conditions:

VBus = ± 27V
 Input Signal = 1 KHz
 Load Impedance = 3 ohms
 Set Gain = 1% clipping 95W

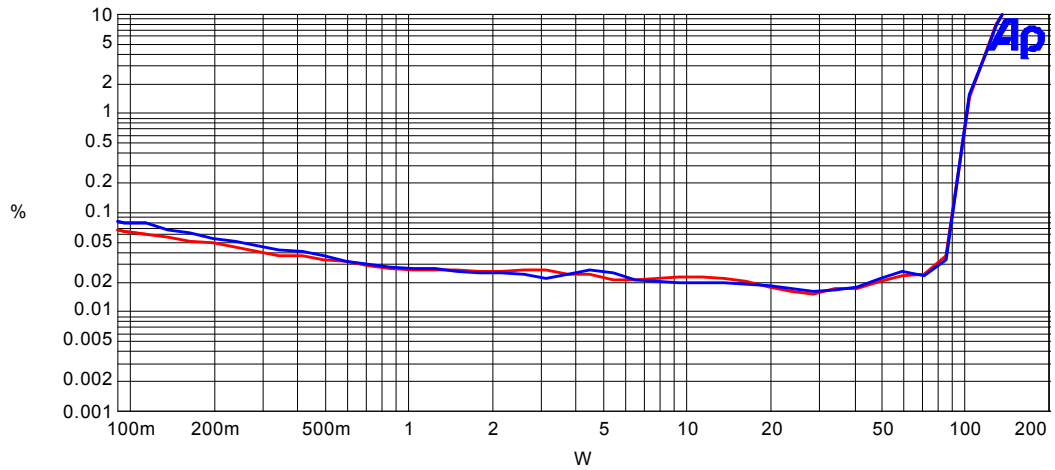

Sweep	Trace	Color	Line Style	Thick	Data	Axis	Comment
5	1	Red	Solid	2	S2.Anlr.THd+N Ratio	Left	CH1 3ohm 27V
5	3	Blue	Solid	2	S2.Anlr.THd+N Ratio	Left	CH2 3ohm 27V

Figure 7

Test Conditions:

VBus = ± 19V
 Input Signal = 1 KHz
 Load Impedance = 2 ohms
 Set Gain = 1% clipping 70W

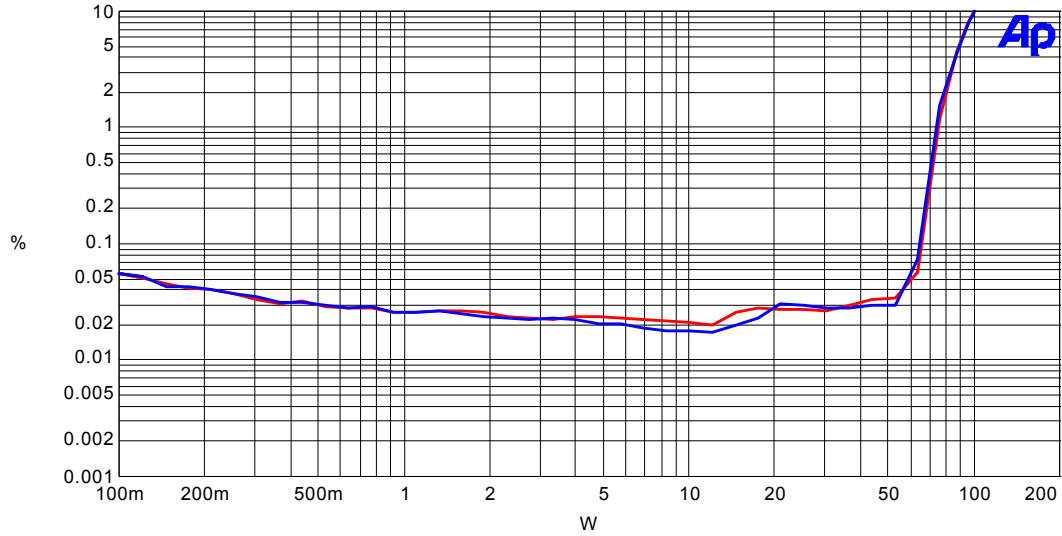

Sweep	Trace	Color	Line Style	Thick	Data	Axis	Comment
1	1	Red	Solid	2	S2.Anlr.TH+D+N Ratio	Left	CH1 2ohm 19V
1	3	Blue	Solid	2	S2.Anlr.TH+D+N Ratio	Left	CH2 2ohm 19V

Figure 8

Frequency Response

Test Conditions:

VBus = ± 31V, 25V, 17V
 Set Output = 1V
 Load Impedance = 4, 3, 2 ohms

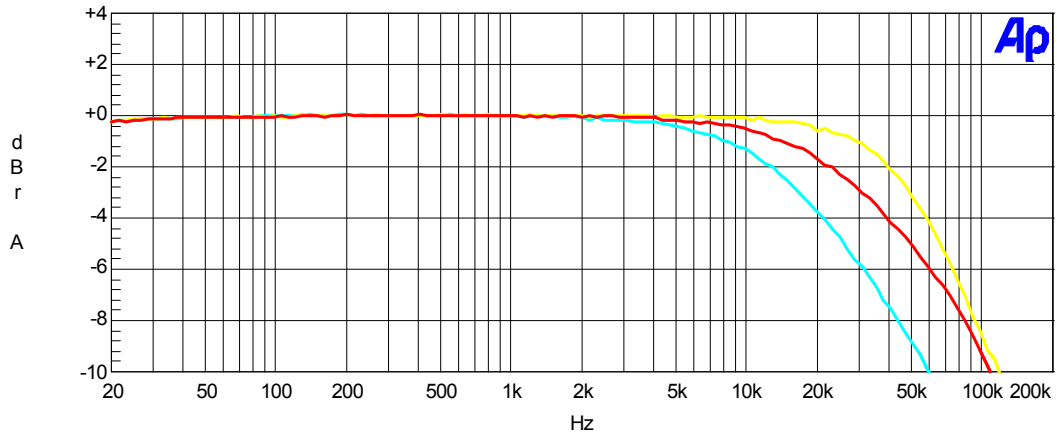

Sweep	Trace	Color	Line Style	Thick	Data	Axis	Comment
1	1	Cyan	Solid	2	Anlr.Level A	Left	Ch2 2ohm +-17V
3	1	Yellow	Solid	2	Anlr.Level A	Left	Ch2 4ohm +-31V
4	1	Red	Solid	2	Anlr.Level A	Left	Ch2 3ohm +-25V

Figure 9

Noise Floor

Test Conditions:

VBus = ± 31V
Load Impedance = 4 ohms
Set Gain = 1% clipping
No Input Signal

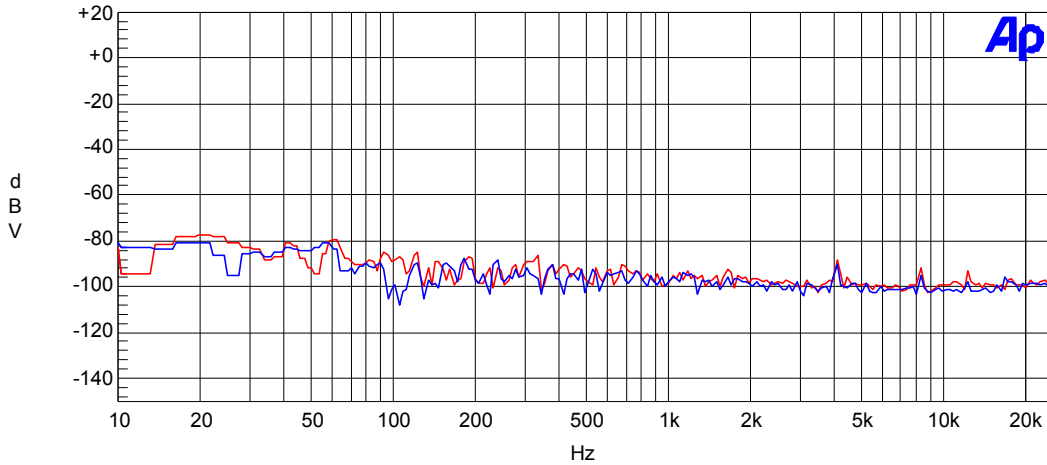

Sweep	Trace	Color	Line Style	Thick	Data	Axis	Comment
1	1	Red	Solid	1	Fft.Ch.1 Ampl	Left	Ch1
1	2	Blue	Solid	1	Fft.Ch.2 Ampl	Left	Ch2

Figure 10

Noise Floor with 1Vrms Output

Test Conditions:

VBus = ± 31V
Output = 1Vrms @ 1 KHz
Load Impedance = 4 ohms
Set Gain = 1% clipping

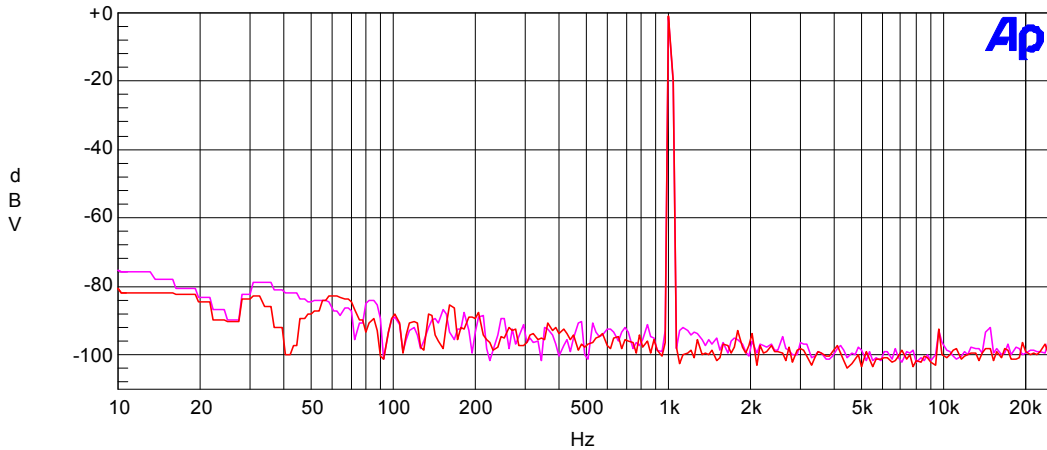

Sweep	Trace	Color	Line Style	Thick	Data	Axis	Comment
1	1	Magenta	Solid	1	Fft.Ch.1 Ampl	Left	Ch1 4ohm
1	2	Red	Solid	1	Fft.Ch.2 Ampl	Left	Ch2 4ohm

Figure 11

Efficiency

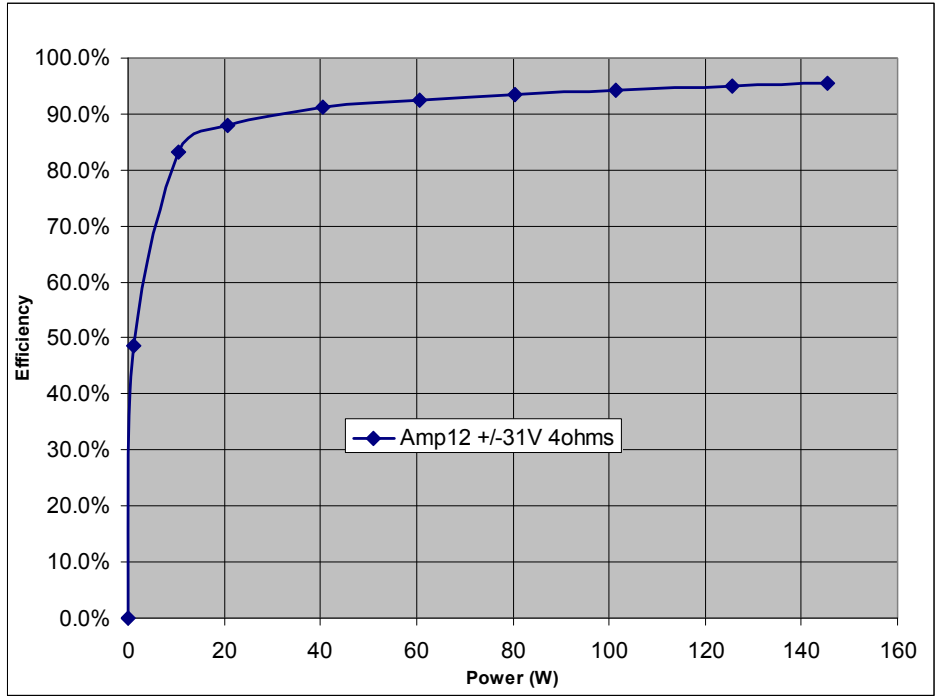

Figure 12

Thermal Information

1) 1/8 Po Thermal information for IRAUDAMP12

Conditions:

- Tamb=25°C natural convection cooling
- Both Channel Driven 1/8Po continuous 30minutes
- Temperature measured by INFRARED Camera
- Measuring temperature point:

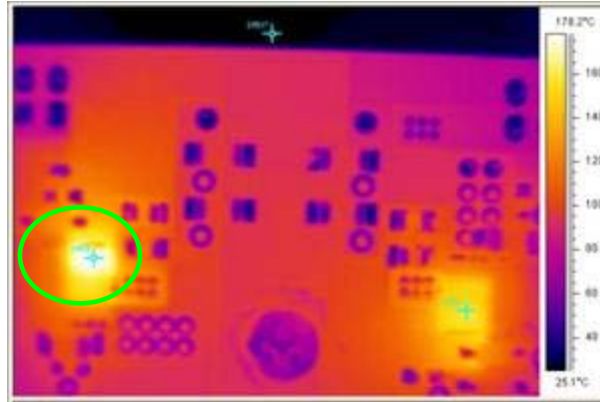

IR4301's temperature saturated $\leq 85^{\circ}\text{C}$ within 30minutes
Figure 13

load impedance	1/8 Power(W)	THD=1% power(W)	THD=10% power(W)
4Ω load	12.5	100	130
	*16.25	*130	*160
3Ω load	10	80	100
	*11.875	*95	*120
2Ω load	6.375	55	70
	*11.125	*70	*90

*With heatsink (Digikey part#:294-1085-ND)

2) Peak Power duration (no heatsink)

Test conditions:

- Vbus=+/-31V for 4 ohms, 25V for 3 ohms, 17.0V for 2 ohms
- 1kHz sine wave signal input ; Both channels driven
- Fsw=400kHz

Test results:

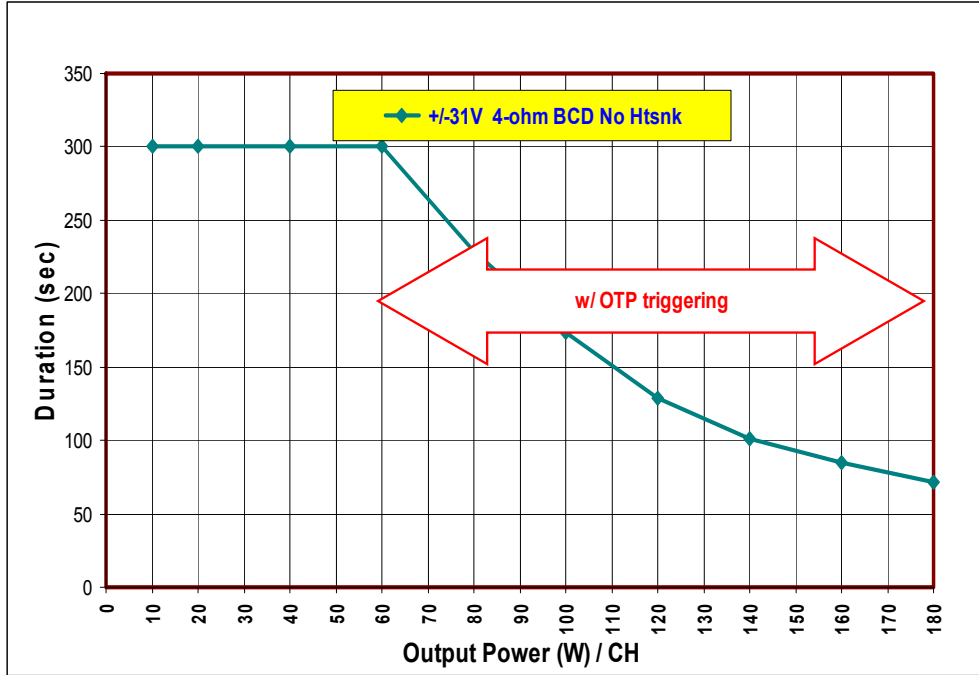

Figure 14

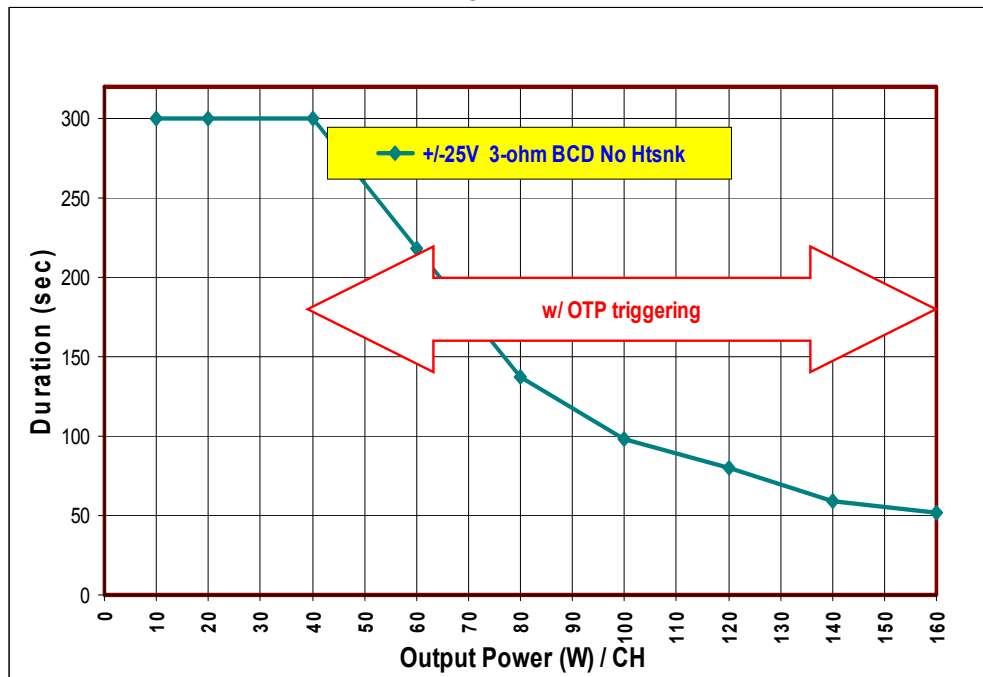

Figure 15

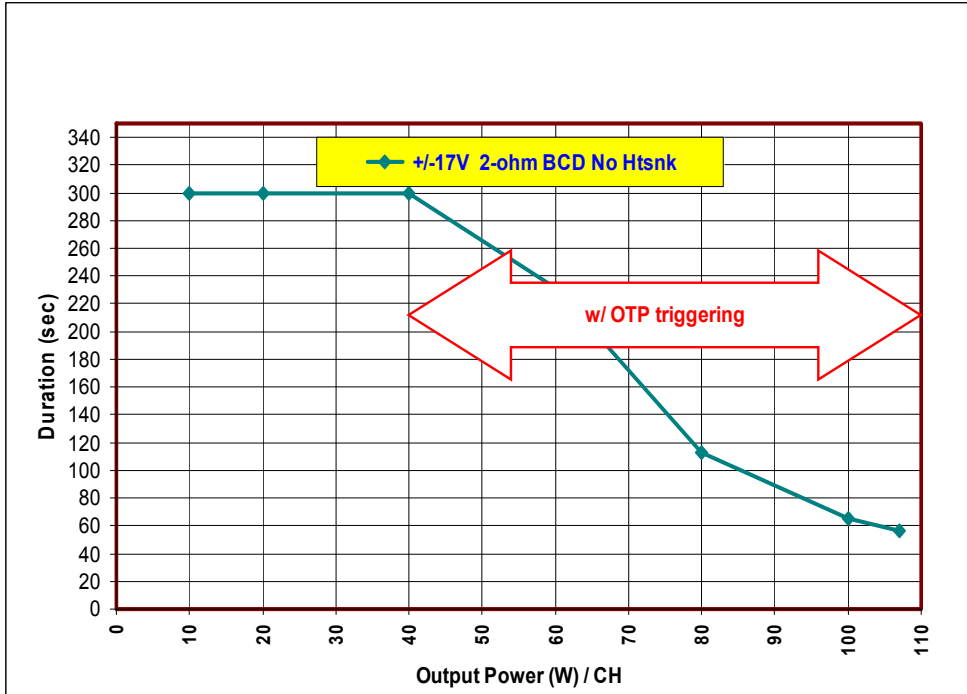

Figure 16

3) Peak Power duration (with heatsink)

Test conditions:

- Vbus= \pm 34V for 4 ohms, 27V for 3 ohms, 19V for 2 ohms
- 1kHz sine wave signal input ; Both channels driven

Test results:

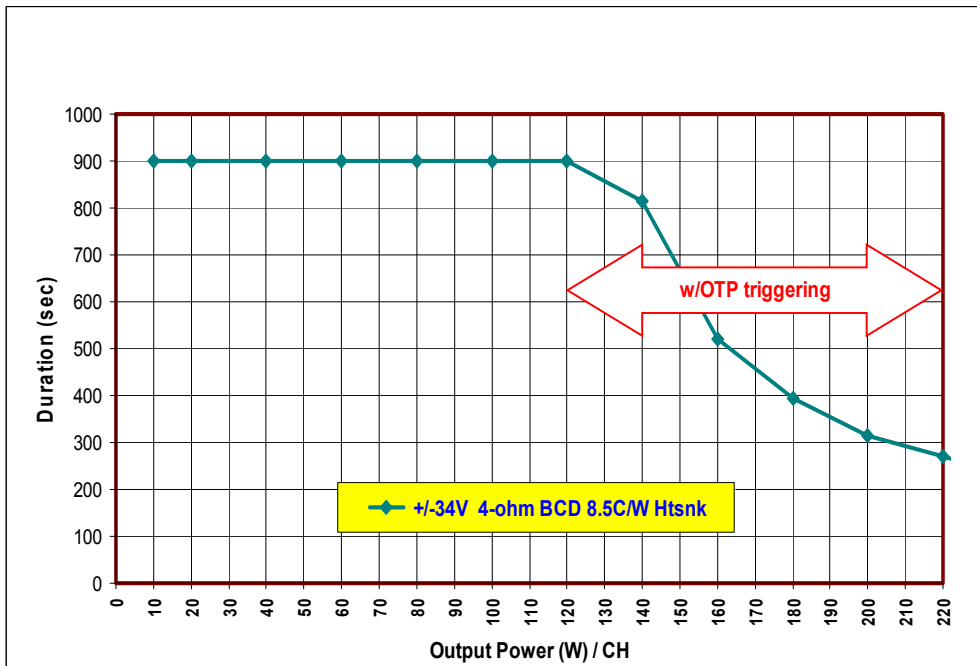

Figure 17

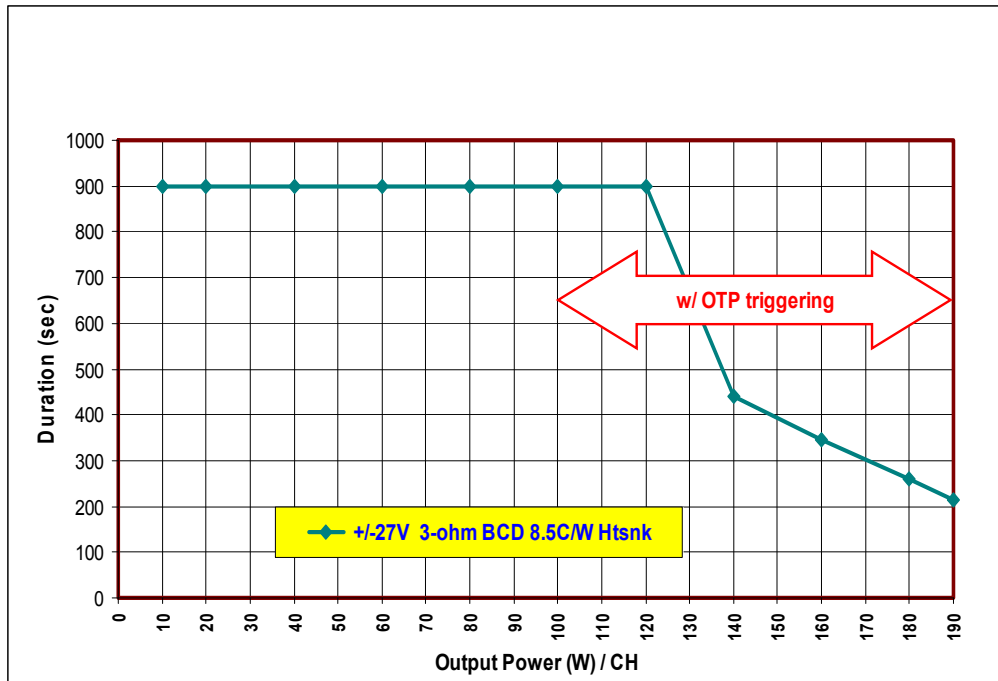

Figure 18

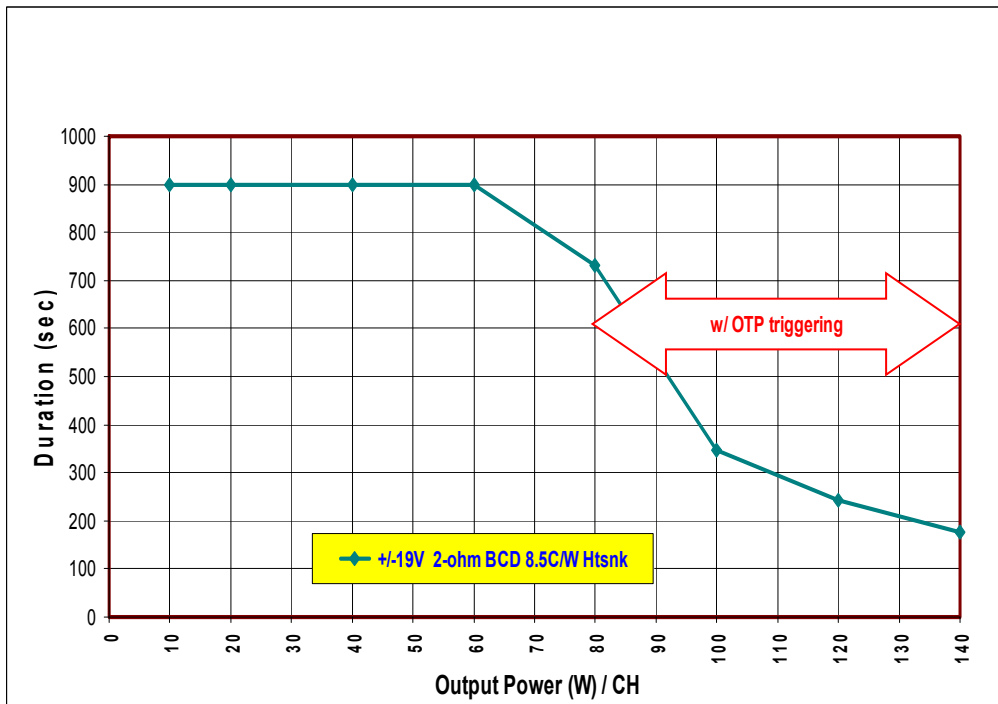

Figure 19

4) Heatsink installation

Heatsink Installation:

- 1, Drill a hole in the center of daughter board.
- 2, Mount heatsink and thermal pad on the back of daughter board.
- 3, Extend daughter board's pins with cables as Figure20.

	Digikey part#
Heatsink	294-1085-ND
Thermal pad	BER161-ND

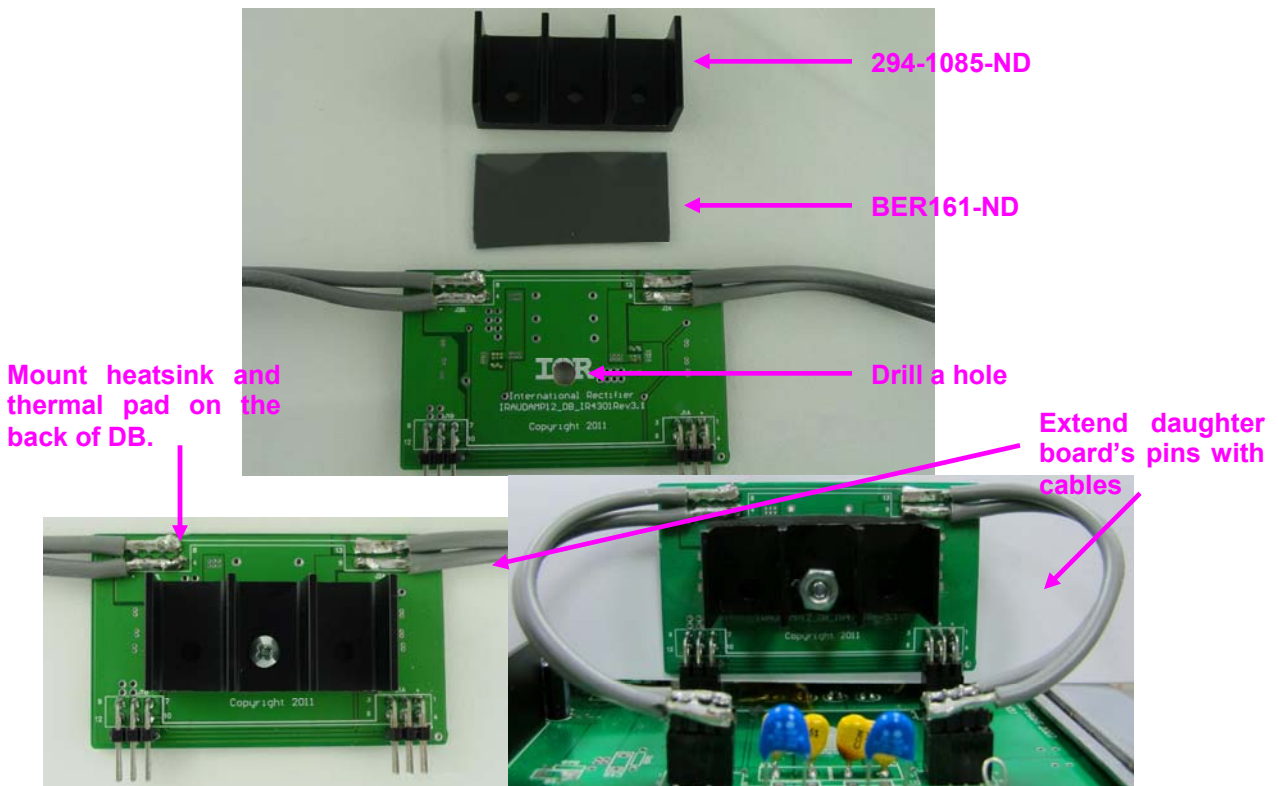

Figure 20

Schematic

Class D, Daughter Board IR4301 Module Schematic

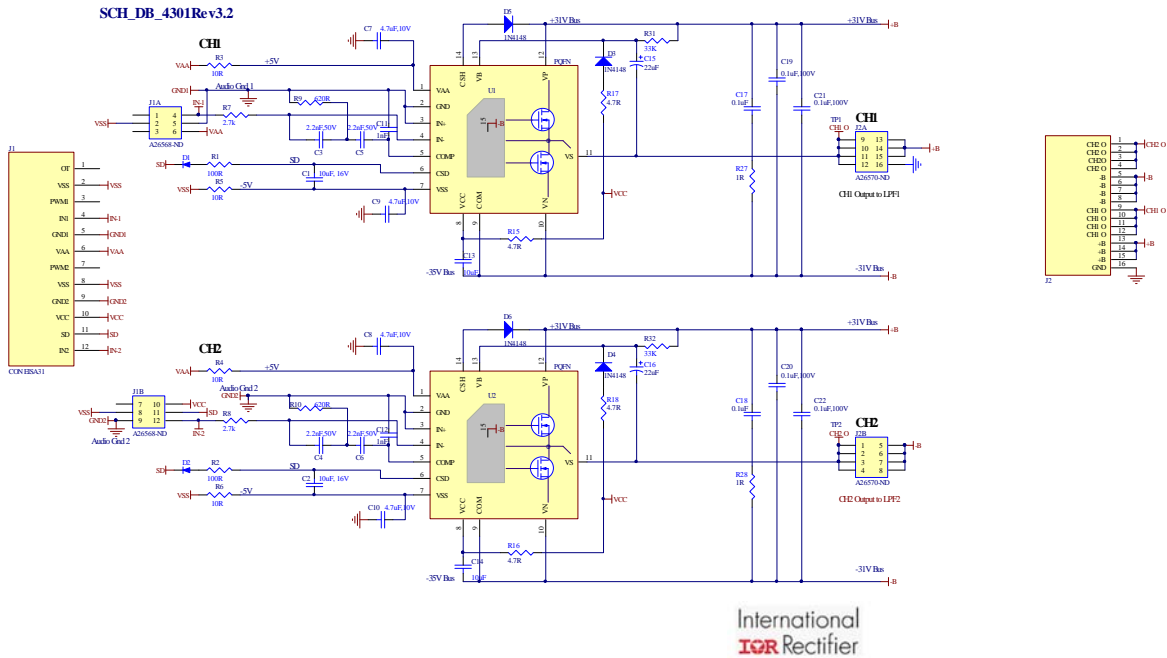

Figure 21

Class D, Mother Board Control Volume and Power Supplies Schematic

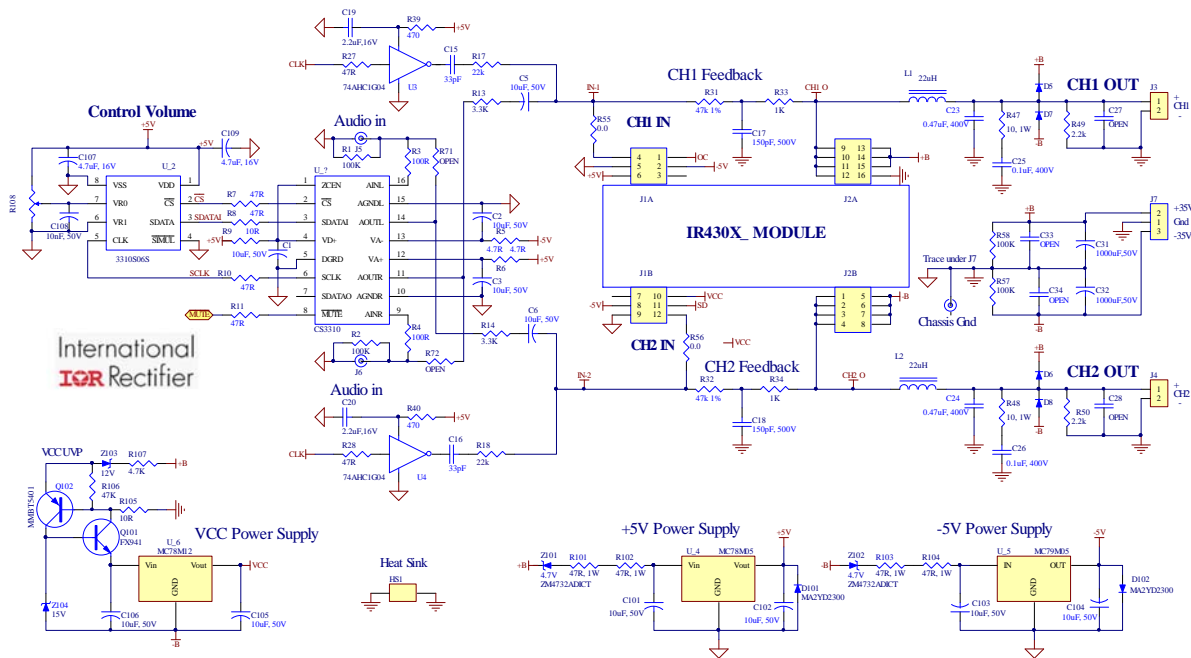

Figure 22

Class D, Mother Board Clock and House Keeping Schematic

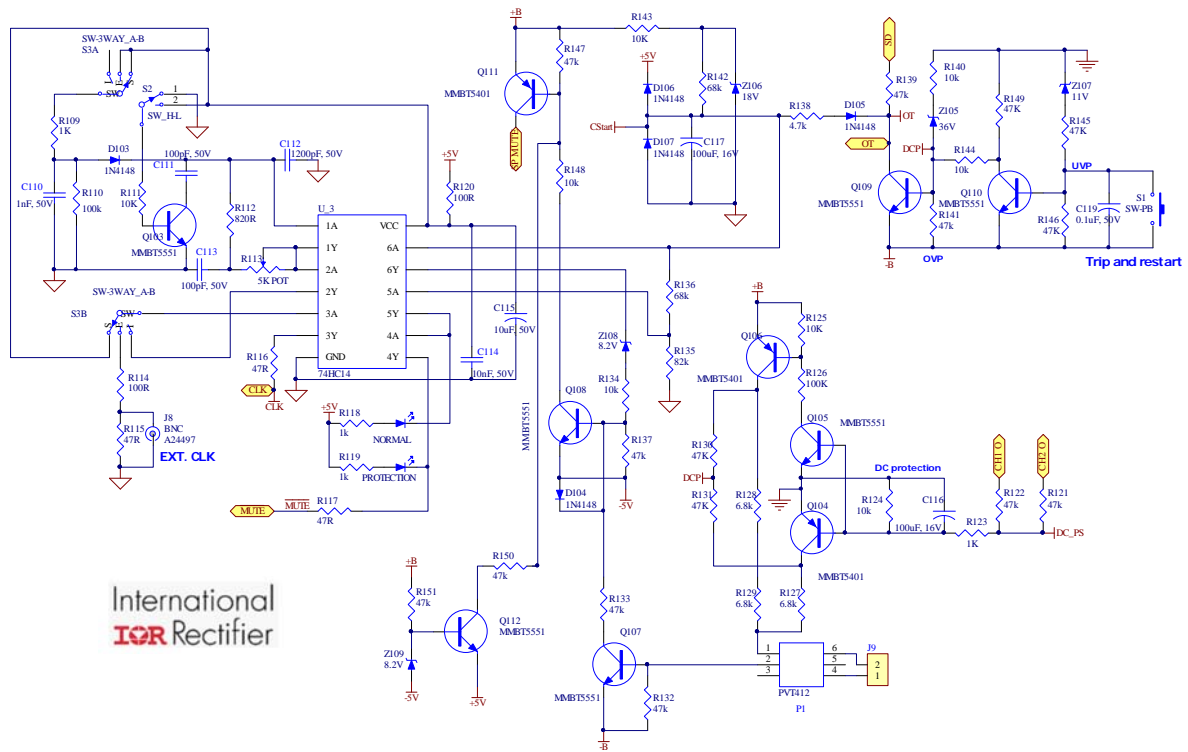

Figure 23

Bill of Materials

IRAUDAMP12 Daughter Board BOM

No	Part Number	Designator	Description	Quantity	Vendor
1	445-1601-1-ND	C1, C2	CAP CER 10UF 16V 20% X7R 1206	2	Digikey
2	445-1309-1-ND	C3, C4, C5, C6	CAP CER 2200PF 50V 10% X7R 0603	4	Digikey
3	587-1442-1-ND	C7, C8, C9, C10	CAP CER 4.7UF 10V 10% X7R 0805	4	Digikey
4	478-1215-1-ND	C11, C12	CAP CER 1000PF 50V 10% X7R 0603	2	Digikey
5	399-4939-1-ND	C13, C14	CAP CER 10UF 16V 20% X7R 1206	2	Digikey
6	445-6797-1-ND	C15, C16	CAP CER 22UF 16V 10% X5R 0805	2	Digikey
7	311-1140-1-ND	C17, C18	CAP CER 0.1UF 50V 10% X7R 0805	2	Digikey
8	478-1529-1-ND	C19, C20, C21, C22	CAP CER 0.1UF 100V 10% X7R 1206	4	Digikey
9	1N4148WS-FDICT-ND	D1, D2	DIODE SWITCH 75V 200MW SOD323	2	Digikey
10	1N4148W-FDICT-ND	D3, D4, D5, D6	DIODE SWITCH 100V 400MW SOD123	4	Digikey
11	A26568-ND	J1A, J1B	CONN HEADER VERT 6POS .100 30AU	2	Digikey
12	A26570-ND	J2A, J2B	CONN HEADER VERT .100 8POS 30AU	2	Digikey
13	RMCF0603JT100RCT-ND	R1, R2	RES 100 OHM 1/10W 5% 0603 SMD	2	Digikey
14	RMCF0603JT10R0CT-ND	R3, R4, R5, R6	RES 10 OHM 1/10W 5% 0603 SMD	4	Digikey
15	RMCF0603FT2K70CT-ND	R7, R8	RES 2.7K OHM 1/10W 1% 0603 SMD	1	Digikey
16	311-620GRCT-ND	R9, R10	RES 620 OHM 1/10W 5% 0603 SMD	2	Digikey
17	311-4.7GRCT-ND	R15, R16, R17, R18	RES 4.7 OHM 1/10W 5% 0603 SMD	4	Digikey
18	311-1.0GRCT-ND	R27, R28	RES 1.0 OHM 1/10W 5% 0603 SMD	2	Digikey
19	RMCF0603JT33K0CT-ND	R31, R32	RES 33K OHM 1/10W 5% 0603 SMD	2	Digikey
20	IR4301	U1, U2	PowerAudio integrated Class D IC	2	IR
*21	294-1085-ND	Heatsink	HEATSINK TRIPLE BLACK TO-220	1	Digikey
*22	BER161-ND	Thermal Pad	THERMAL PAD .020" 4X4" GAPPAD	1/6	Digikey
*24	H724-ND	Nut Hex	NUT HEX 4-40 STAINLESS STEEL	1/100	Digikey
*25	H705-ND	Screw	SCREW MACHINE PHIL 4-40X1/2 SS	1/100	Digikey

*Heatsink is an option for IRAUDAMP12 to deliver high power up to 160W/4Q

IRAUDAMP12 Mother Board BOM

NO	Part No	Designator	Description	#	Vender
1	565-1106-ND	C1, C5, C6, C101, C102, C103, C104, C105, C106, C115	CAP ALUM 10UF 50V 20% RADIAL	10	Digikey
2	565-1103-ND	C2, C3	CAP ALUM 2.2UF 50V 20% RADIAL	2	Digikey
3	478-1281-1-ND	C15, C16	CAP CER 33PF 100V 5% NP0 0805	2	Digikey
4	338-2598-ND	C17, C18	CAP MICA 150PF 500V 5% RADIAL	2	Digikey
5	PCC1931CT-ND	C19, C20	CAP CER 2.2UF 16V 10% X7R 1206	2	Digikey
6	PCC104BCT-ND	C119	CAP CER 0.1UF 50V 10% X7R 1206	1	Digikey
7	495-1315-ND	C23, C24	CAP FILM 0.47UF 400VDC RADIAL	2	Digikey
8	495-1311-ND	C25, C26	CAP FILM 0.1UF 400VDC RADIAL	2	Digikey
9	565-1114-ND	C31, C32	CAP ALUM 1000UF 50V 20% RADIAL	2	Digikey
10	PCC2323CT-ND	C107, C109	CAP CER 4.7UF 16V 10% X5R 0805	2	Digikey
11	PCC103BNCT-ND	C108, C114	CAP CER 10000PF 50V 10% X7R 0805	2	Digikey
12	PCC102CGCT-ND	C110	CAP CER 1000PF 50V 5% NP0 0805	1	Digikey

13	PCC101CGCT-ND	C111, C113	CAP CER 100PF 50V 5% NP0 0805	2	Digikey
14	478-1372-1-ND	C112	CAP CER 1200PF 50V 10% X7R 0805	1	Digikey
15	565-1037-ND	C116, C117	CAP ALUM 100UF 16V 20% RADIAL	2	Digikey
16	1N4148W-FDICT-ND	D103, D104, D105, D106, D107	DIODE SWITCH 100V 400MW SOD123	5	Digikey
17	MURA120T3GOSCT-ND	D5, D6, D7, D8	DIODE ULTRA FAST 1A 200V SMA	4	Digikey
18	MA2YD2300LCT-ND	D101, D102	DIODE SCHOTTKY 25V 1.0A MINI-2P	2	Digikey
19	294-1086-ND	HS1	HEATSINK HORZ SIX BLACK TO-220	1	Digikey
20	A32934-ND	J1A, J1B	CONN RECEPT 6POS .100 VERT DUAL	2	Digikey
21	A32935-ND	J2A, J2B	CONN RECEPT 8POS .100 VERT DUAL	2	Digikey
22	277-1271-ND or 651-1714971	J3, J4	CONN TERM BLOCK 2POS 9.52MM PCB	2	Digikey or Mouser
23	CP-1422-ND	J5, J6	CONN RCA JACK R/A BLUE PCB	2	Digikey
24	277-1272-ND or 651-1714984	J7	CONN TERM BLOCK 3POS 9.52MM PCB	1	Digikey or Mouser
25	A32248-ND	J8	CONN JACK BNC R/A 50 OHM PCB TIN	1	Digikey
26	ED1567	J9	TERMINAL BLOCK 7.50MM VERT 2POS	1	Digikey
27	7G14A-220M-B	L1, L2	Class D inductor, 22uH	2	Inductors, Inc
	911-1D14A-220M				Mouser
	7G17A-220M-B				Inductors, Inc
	911-1D17A-220M				Mouser
28	160-1143-ND	NORMAL	LED 3MM GREEN TRANSPARENT	1	Digikey
29	PVT412PBF-ND	P1	IC RELAY PHOTOVO 400V 140MA 6DIP	1	Digikey
30	160-1140-ND	PROTECTION	LED 3MM HI-EFF RED TRANSPARENT	1	Digikey
31	FCX491CT-ND	Q101	TRANSISTOR NPN 60V 1A SOT-89	1	Digikey
32	MMBT5401-FDICT-ND	Q102, Q104, Q106, Q111	TRANS PNP 150V 350MW SMD SOT23-3	4	Digikey
33	MMBT5551-FDICT-ND	Q103, Q105, Q107, Q108, Q109, Q110, Q112	TRANS NPN 160V 350MW SMD SOT23-3	7	Digikey
34	P100KACT-ND	R1, R2, R57, R58, R110, R126	RES 100K OHM 1/8W 5% 0805 SMD	6	Digikey
35	P100ACT-ND	R3, R4, R114	RES 100 OHM 1/8W 5% 0805 SMD	3	Digikey
36	P4.7ECT-ND	R5, R6	RESISTOR 4.7 OHM 1/4W 5% 1206	2	Digikey
37	P47ACT-ND	R7, R8, R10, R11, R27, R28, R115, R116, R117	RES 47 OHM 1/8W 5% 0805 SMD	9	Digikey
38	P10ACT-ND	R9, R105	RES 10 OHM 1/8W 5% 0805 SMD	2	Digikey
39	P3.3KACT-ND	R13, R14	RES 3.3K OHM 1/8W 5% 0805 SMD	2	Digikey
40	P22KACT-ND	R17, R18	RES 22K OHM 1/8W 5% 0805 SMD	2	Digikey
41	P47KACT-ND	R106, R121, R122, R130, R131, R132, R133, R137, R139, R141, R145, R146, R147, R149, R150, R151	RES 47K OHM 1/8W 5% 0805 SMD	16	Digikey
42	P0.0ACT-ND	R55, R56	RES 0.0 OHM 1/8W 0805 SMD	2	Digikey
43	P470ACT-ND	R39, R40	RES 470 OHM 1/8W 5% 0805 SMD	2	Digikey
44	P100ECT-ND	R120	RES 100 OHM 1/4W 5% 1206 SMD	1	Digikey
45	PT47KAFCT-ND	R31, R32	RES 47.0K OHM 1W 1% 2512 SMD	2	Digikey
46	P1.0KECT-ND	R33, R34	RES 1.0K OHM 1/4W 5% 1206 SMD	2	Digikey
47	P1.0KACT-ND	R109, R118, R119, R123	RES 1.0K OHM 1/8W 5% 0805 SMD	4	Digikey
48	PT10XCT	R47, R48	RES 10 OHM 1W 5% 2512 SMD	2	Digikey
49	P2.2KECT-ND	R49, R50	RES 2.2K OHM 1/4W 5% 1206 SMD	2	Digikey
50	PT47XCT-ND	R101, R102, R103, R104	RES 47 OHM 1W 5% 2512 SMD	4	Digikey

51	P4.7KACT-ND	R107, R138	RES 4.7K OHM 1/8W 5% 0805 SMD	2	Digikey
52	CT2265-ND	R108	POT 10K OHM 1/8W CARB VERTICAL	1	Digikey
53	P10KACT-ND	R111, R124, R125, R134, R140, R143, R144, R148	RES 10K OHM 1/8W 5% 0805 SMD	8	Digikey
54	P820ACT-ND	R112	RES 820 OHM 1/8W 5% 0805 SMD	1	Digikey
55	3362H-502LF-ND	R113	TRIMMER 5K OHM 0.5W TH	1	Digikey
56	P6.8KECT-ND	R127, R128, R129	RES 6.8K OHM 1/4W 5% 1206 SMD	3	Digikey
57	P82KACT-ND	R135	RES 82K OHM 1/8W 5% 0805 SMD	1	Digikey
58	P68KACT-ND	R136, R142	RES 68K OHM 1/8W 5% 0805 SMD	2	Digikey
59	P8010S-ND	S1	SWITCH TACTILE SPST-NO 0.02A 15V	1	Digikey
60	EG1908-ND	S2	SWITCH SLIDE DPDT 12V .1A L=4	1	Digikey
61	EG1944-ND	S3	SWITCH SLIDE DP3T .2A L=6MM	1	Digikey
62	296-1089-1-ND	U3, U4	IC SNGL INVERTER GATE SOT23-5	2	Digikey
63	73C8016 or 72J5420	U_1	IC, DIGITAL VOLUME CONTROL, SOIC-16	1	Newark
64	3310-IR01	U_2	CS3310 Stand-alone Controller	1	*Tachyonix
65	296-1194-1-ND	U_3	IC HEX SCHMITT-TRIG INV 14-SOIC	1	Digikey
66	MC78M05CTGOS-ND	U_4	IC REG VOLT POS 500MA 5V TO220AB	1	Digikey
67	LM79M05CT-ND	U_5	IC VOLT REG NEG 5V 500MA TO220-3	1	Digikey
68	LM78M12CT-ND	U_6	IC VOLT REG 12V 500MA TO220-3	1	Digikey
69	1SMA5917BT3GOSCT-ND	Z101, Z102	DIODE ZENER 4.7V 1.5W SMA	2	Digikey
70	BZT52C12-FDICT-ND	Z103	DIODE ZENER 12V 500MW SOD-123	1	Digikey
71	BZT52C15-FDICT-ND	Z104	DIODE ZENER 15V 500MW SOD-123	1	Digikey
72	BZT52C36-FDICT-ND	Z105	DIODE ZENER 36V 500MW SOD-123	1	Digikey
73	BZT52C18-FDICT-ND	Z106	DIODE ZENER 18V 500MW SOD-123	1	Digikey
74	BZT52C11-FDICT-ND	Z107	DIODE ZENER 11V 500MW SOD-123	1	Digikey
75	BZT52C8V2-FDICT-ND	Z108, Z109	DIODE ZENER 8.2V 500MW SOD-123	2	Digikey
76	10M7578	Volume Knob	ROUND KNURLED KNOB, 6MM	1	Newark
77	82K6096	Thermally TO-220 mounting kit with screw	THERMALLOY - 4880G - Mounting Kit	3	Newark
78	8401K-ND	1/2" Standoffs 4-40	STDOFF HEX M/F 4-40 .500"L ALUM	5	Digikey
79	H724-ND	4-40 Nut	NUT HEX 4-40 STAINLESS STEEL	5	Digikey
80	H729-ND	No. 4 Lock Washer	WASHER LOCK INTERNAL #4 SS	5	Digikey

*Tachyonix Corporation, <http://www.tachyonix.co.jp>

PCB Specifications

- Two Layers SMT PCB with through holes
- 1/16 thickness
- 2/0 OZ Cu
- FR4 material
- 10 mil lines and spaces
- Solder Mask to be Green enamel EMP110 DBG (CARAPACE) or Enthone Endplate DSR-3241 or equivalent.
- Silk Screen to be white epoxy non conductive per IPC-RB 276 Standard.
- All exposed copper must finished with TIN-LEAD Sn 60 or 63 for 100u inches thick.
- Tolerance of PCB size shall be 0.010 –0.000 inches
- Tolerance of all Holes is -.000 + 0.003"
- PCB acceptance criteria as defined for class II PCB'S standards.

Daughter Board

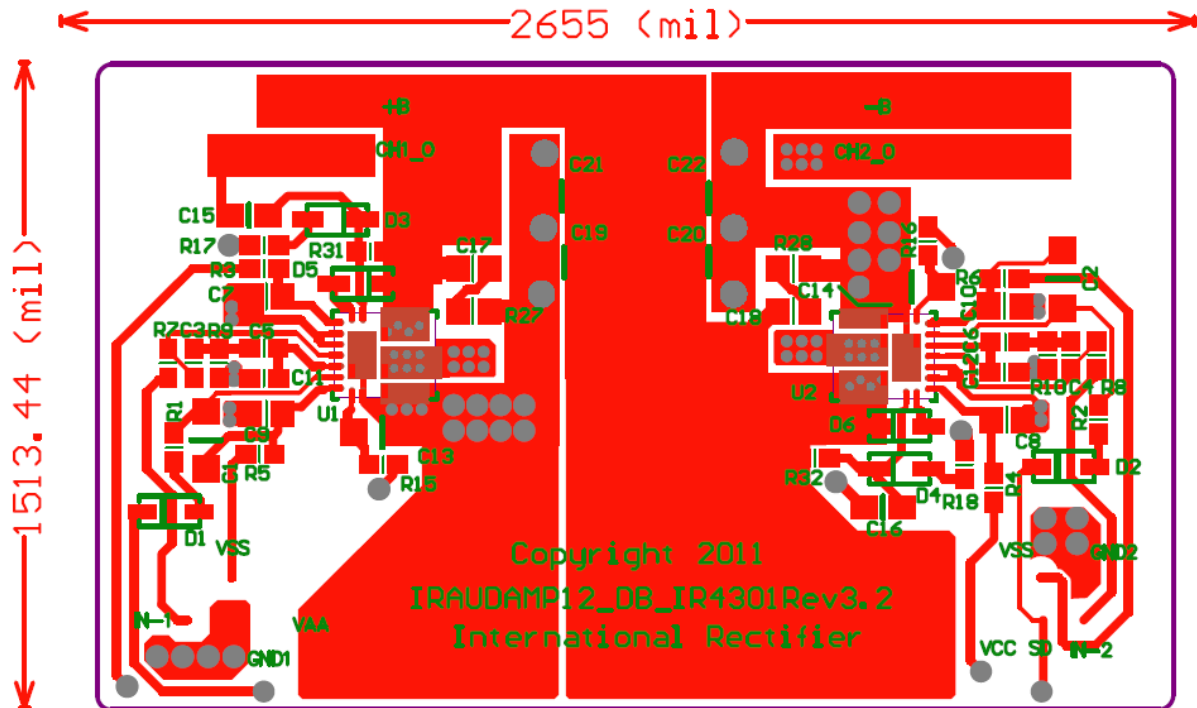

Figure 24

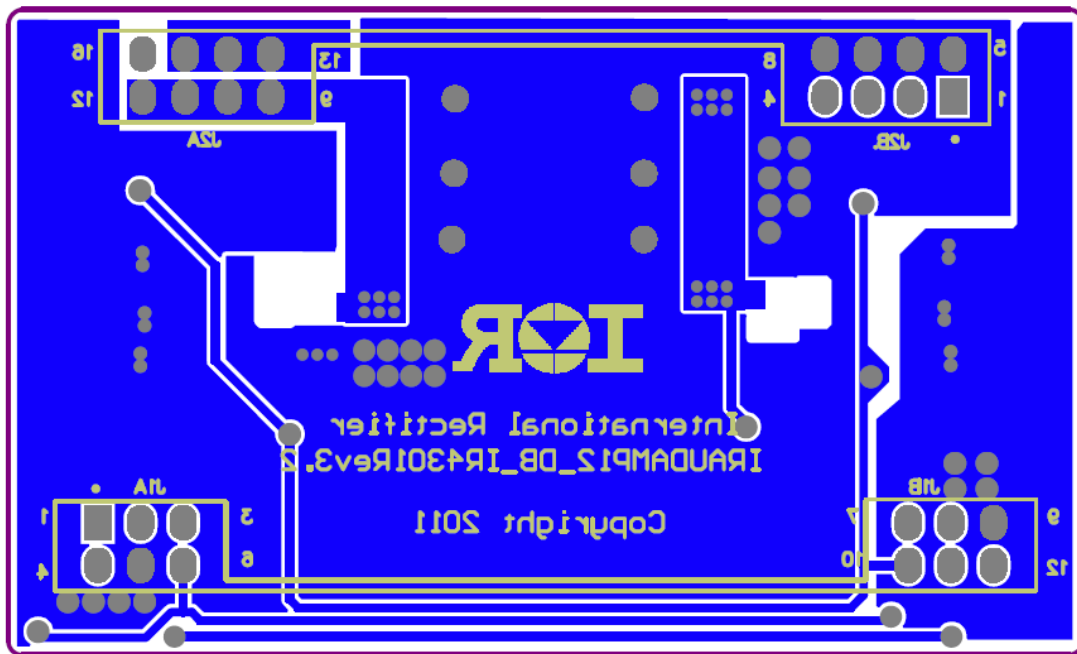

Figure 25

Mother Board

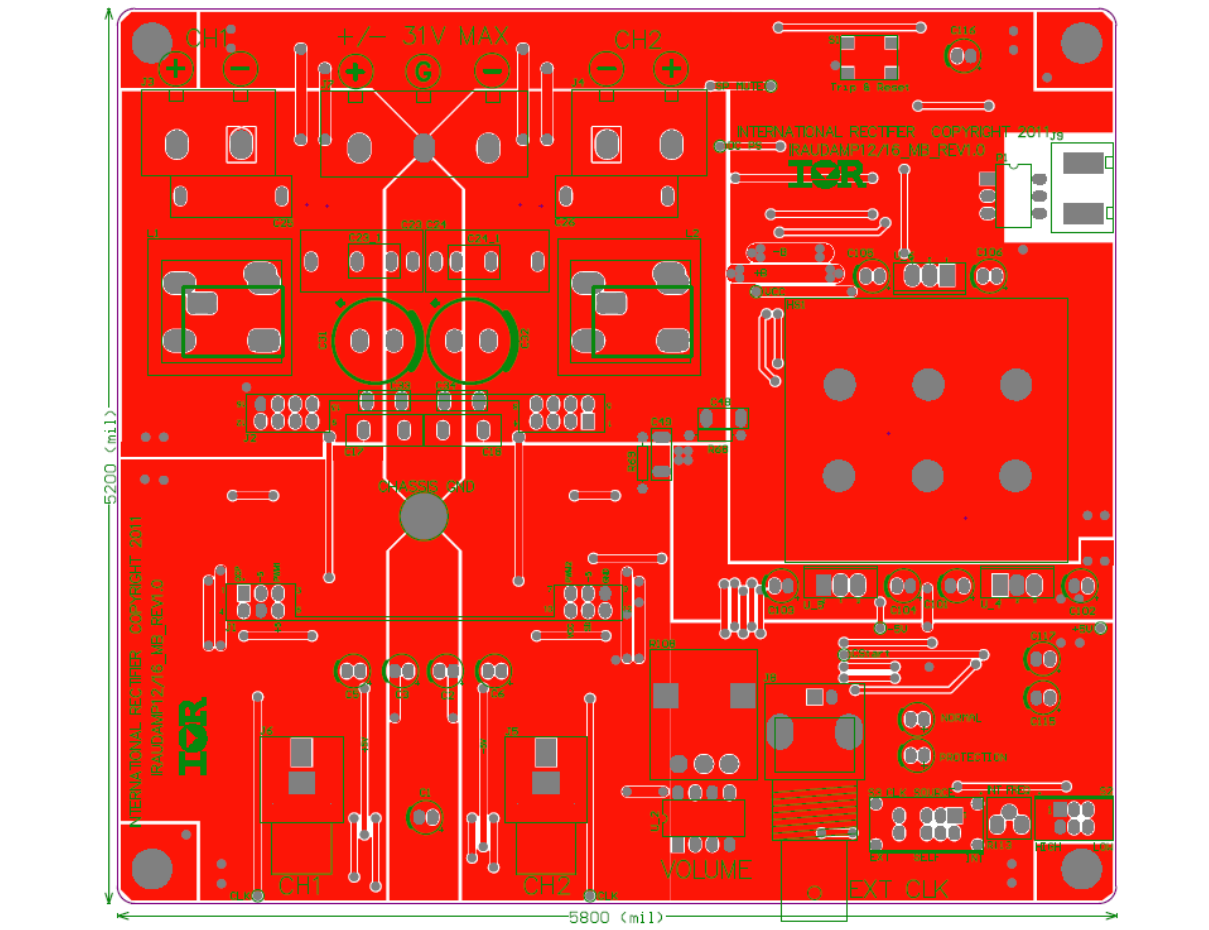

Figure 26

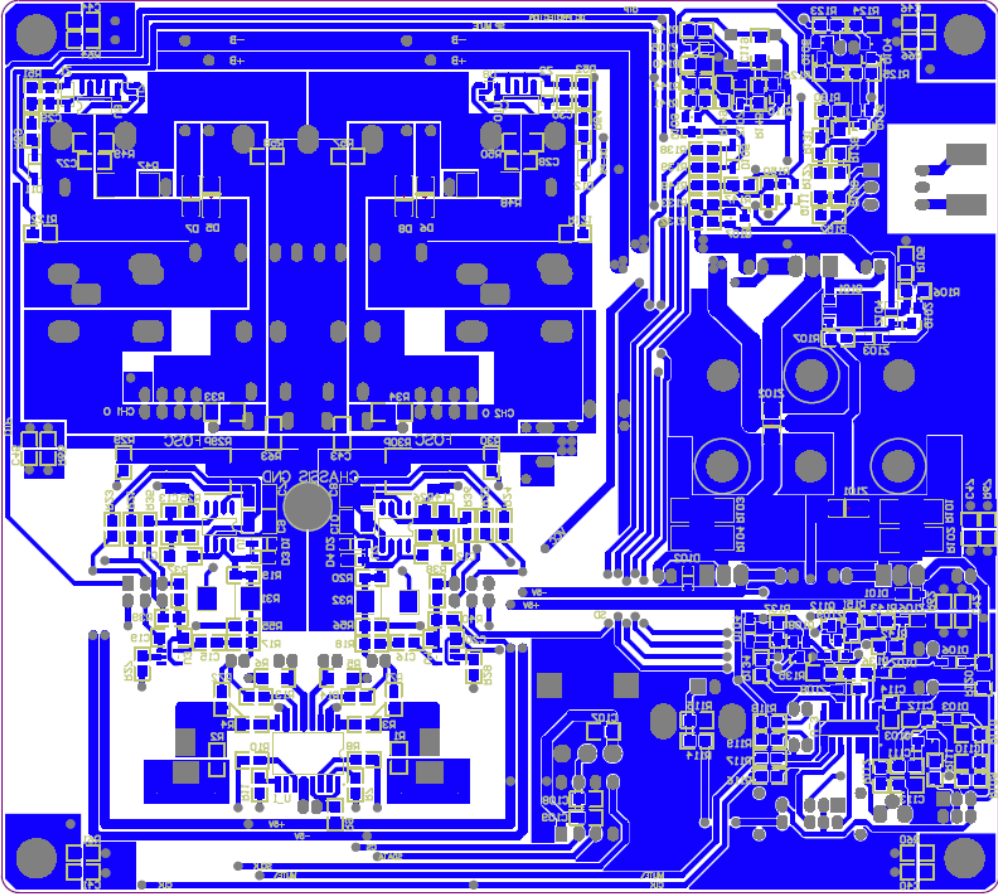

Figure 27

单击下面可查看定价，库存，交付和生命周期等信息

[>>Infineon Technologies\(英飞凌\)](#)