

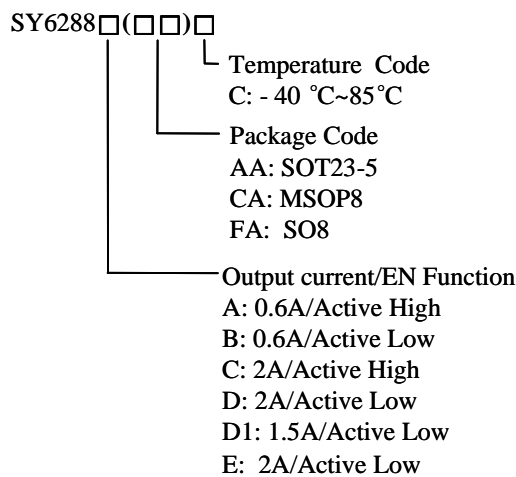

General Description

SY6288 is an ultra-low $R_{DS(ON)}$ switch with current limiting function to protect the power source from over current and short circuit conditions.

Ordering Information



Features

- Distribution voltages: 2.5V to 5.5V
- Over temperature shutdown and automatic retry
- Reverse blocking (no body diode)
- At shutdown, OUT can be forced higher than IN
- Fault flag (OCB) output for over current and fault conditions
- Automatic output discharge at shutdown
- Built-in softstart
- 0.4ms rise time
- RoHS Compliant and Halogen Free
- Two Enable polarities and three current levels
 - SY6288A: Active High/0.6A
 - SY6288B: Active Low/0.6A
 - SY6288C: Active High/2A
 - SY6288D: Active Low/2A
 - SY6288D1: Active Low/1.5A
 - SY6288E: Active Low/2A
- Compact packages minimize board space: SOT23-5, SO8, MSOP8

Typical Application Circuit

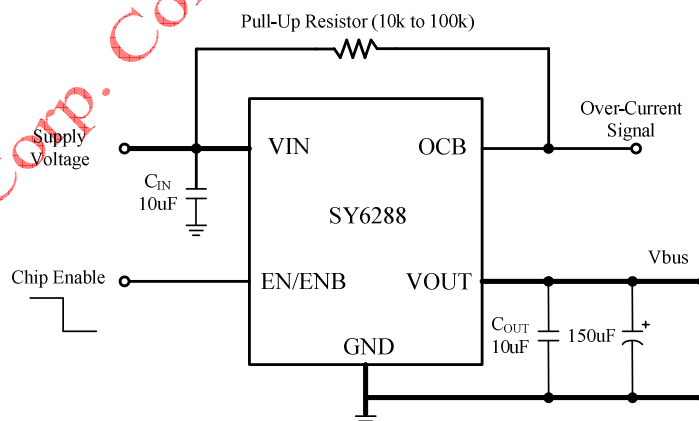

Note: A low-ESR 150uF aluminum electrolytic or tantalum between VOUT and GND is strongly recommended.

Pin Configurations (Top View)

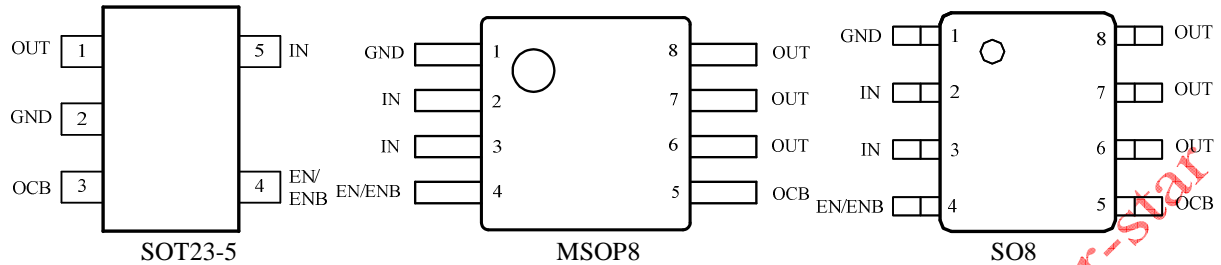

Part Number	Package type	Top Mark ^①
SY6288AAAC	SOT23-5	CW _{xyz}
SY6288ACAC	MSOP8	ABT _{xyz}
SY6288AFAC	SO8	AAJ _{xyz}
SY6288BAAC	SOT23-5	DB _{xyz}
SY6288BCAC	MSOP8	ABD _{xyz}
SY6288BFAC	SO8	AAJ _{xyz}
SY6288CAAC	SOT23-5	DF _{xyz}
SY6288CCAC	MSOP8	ABU _{xyz}
SY6288CFAC	SO8	AAM _{xyz}
SY6288DAAC	SOT23-5	BU _{xyz}
SY6288DCAC	MSOP8	ABE _{xyz}
SY6288DFAC	SO8	AAN _{xyz}
SY6288D1AAC	SOT23-5	DS _{xyz}
SY6288D1CAC	MSOP8	ACK _{xyz}
SY6288D1FAC	SO8	ACJ _{xyz}
SY6288EAAC	SOT23-5	CO _{xyz}
SY6288ECAC	MSOP8	ABW _{xyz}
SY6288EFAC	SO8	ABV _{xyz}

Note ①: x=year code, y=week code, z= lot number code.

Functional Pin Description

Pin Name	Pin Number (SO8, MSOP8)	Pin number (SOT23-5)	Pin Description
IN	2,3	5	Input pin
GND	1	2	Ground pin
OUT	6,7,8	1	Output pin
EN- SY6288A/C ENB- SY6288B/D/E	4	4	ON/OFF control. Don't float. EN: high enable. ENB: low enable.
OCB	5	3	Open Drain Fault Flag



Absolute Maximum Ratings (Note 1)

All pins	6V
Power Dissipation, P_D @ $T_A = 25^\circ\text{C}$ SOT23-5/MSOP8/SO8	0.4/0.5/0.65W
Package Thermal Resistance (Note 2)	
SOT23-5/MSOP8/SO8, θ_{JA}	250/150/90°C/W
SOT23-5/MSOP8/SO8, θ_{JC}	130/ 65/ 45°C/W
Junction Temperature Range	150°C
Lead Temperature (Soldering, 10 sec.)	260°C
Storage Temperature Range	-65°C to 150°C
ESD Susceptibility (Note 2)	
HBM (Human Body Mode)	2kV
MM (Machine Mode)	200V

Recommended Operating Conditions (Note 3)

IN	2.5V to 5.5V
EN/ENB	-0.3V to $V_{IN}+0.3V$
All other pins	0-5.5V
Junction Temperature Range	-40°C to 125°C
Ambient Temperature Range	-40°C to 85°C



Electrical Characteristics

($V_{IN} = 5V$, $C_L = 1\mu F$, per channel, $T_A = 25^\circ C$ unless otherwise specified)

Parameter	Symbol	Test Conditions	Min	Typ	Max	Unit
Input Voltage Range	V_{IN}		2.5		5.5	V
Shutdown Input Current	I_{SHDN}	Rload=open, switch off		0.1	1	μA
Quiescent Supply Current	I_Q	Rload=open, switch on		32		μA
FET RON	$R_{DS(ON)}$	SOT23-5(SY6288A/B/C/D/D1)		80		m Ω
		SOT23-5(SY6288E)		70		m Ω
		MSOP8 SY6288A/B/C/D/D1)		80		m Ω
		MSOP8 SY6288E)		70		m Ω
		SO8(SY6288A/B/C/D/D1)		85		m Ω
		SO8(SY6288E)		75		m Ω
Current Limit	I_{LIM}	SY6288A/B	0.8			A
		SY6288C/D	2.1			A
		SY6288D1	1.6			A
		SY6288E	2.2			A
EN/ \overline{EN} threshold	Logic-Low Voltage	V_{IL}			0.8	V
	Logic-High Voltage	V_{IH}		2		V
IN UVLO threshold	$V_{IN,UVLO}$				2.4	V
IN UVLO hysteresis	$V_{IN,HYS}$			0.1		V
Turn-ON time	T_{ON}	$R_L = 5\text{ohm}$		400		μs
Turn-OFF time	T_{OFF}				200	μs
OCB low resistance	R_{OCB}			10		Ω
OCB Delay Time	T_{OCB_Delay}			10		ms
OUT shutdown discharge resistance	R_{DIS}			10		Ω
Thermal Shutdown Temperature	T_{SD}			150		$^\circ C$
Thermal Shutdown Hysteresis				20		$^\circ C$

Note 1: Stresses listed as the above “Absolute Maximum Ratings” may cause permanent damage to the device. These are for stress ratings. Functional operation of the device at these or any other conditions beyond those indicated in the operational sections of the specifications is not implied. Exposure to absolute maximum rating conditions for extended periods may remain possibility to affect device reliability.

Note 2: θ_{JA} is measured in the natural convection at $T_A = 25^\circ C$ on a low effective single layer thermal conductivity test board of JEDEC 51-3 thermal measurement standard.

Note 3: The device is not guaranteed to function outside its operating conditions



SILERGY

Typical Operating Characteristics

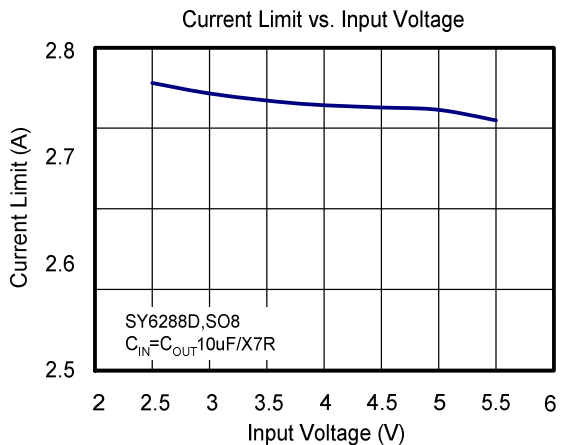
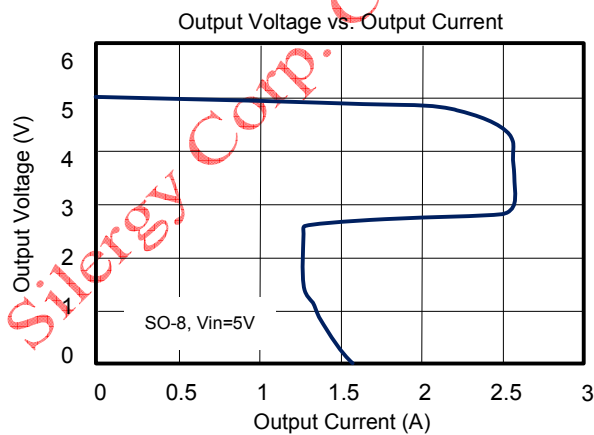
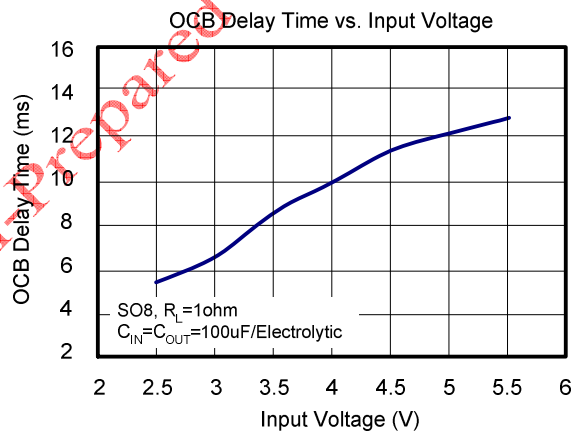
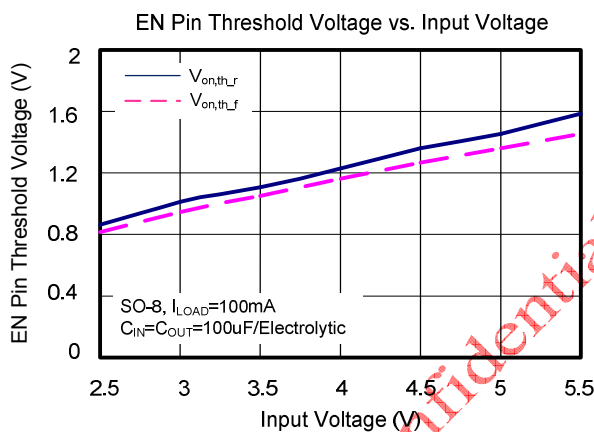
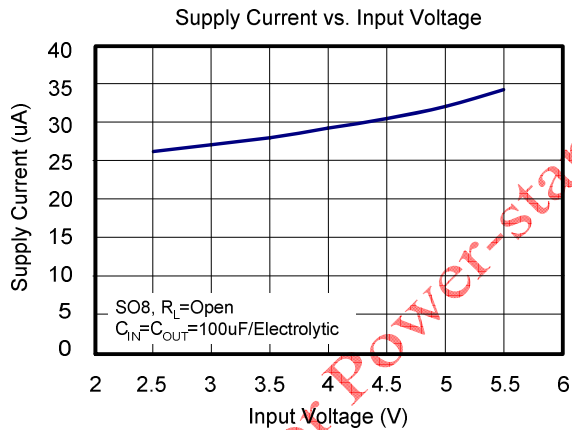
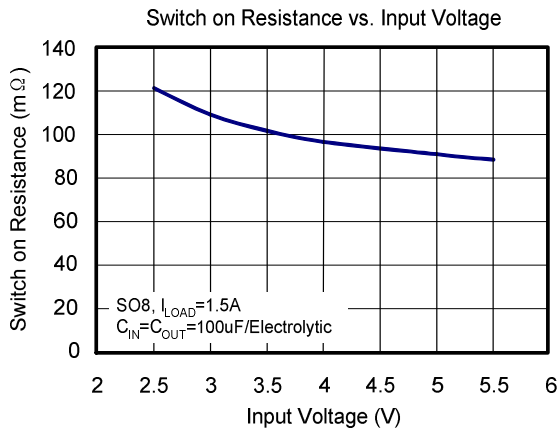

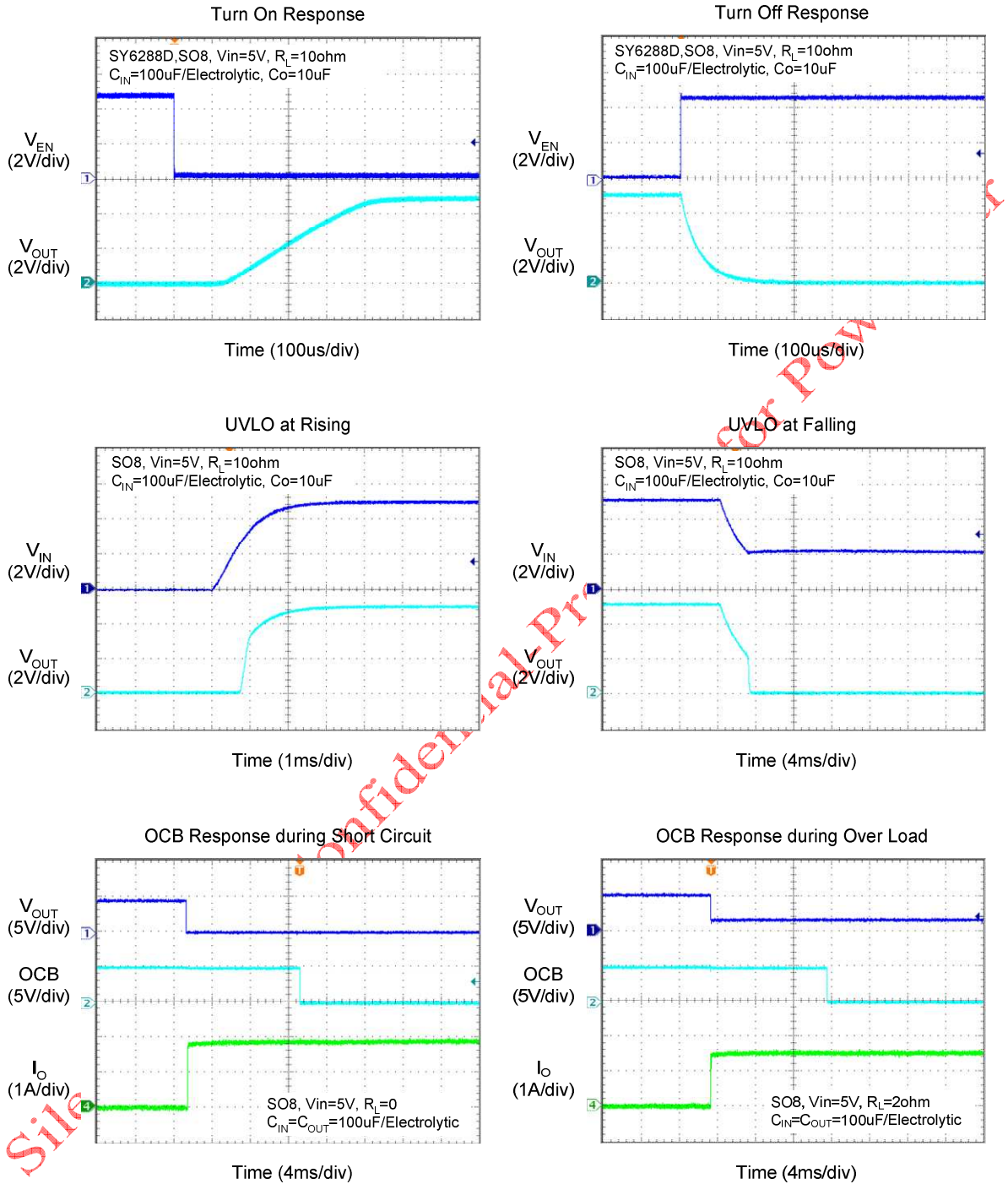

Block diagram

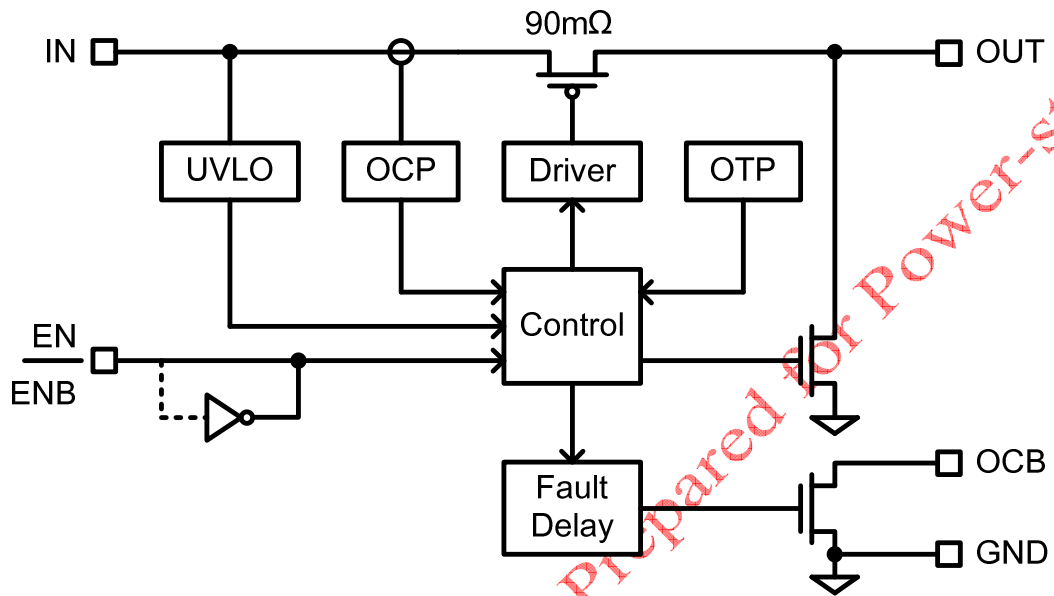

SOT23-5L Package Outline & PCB layout

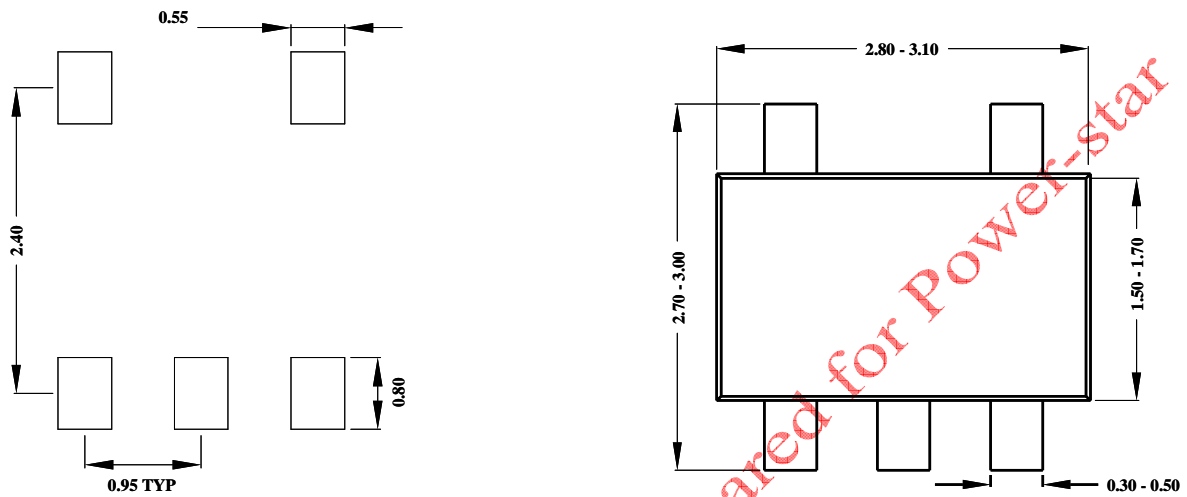

Recommended Pad Layout

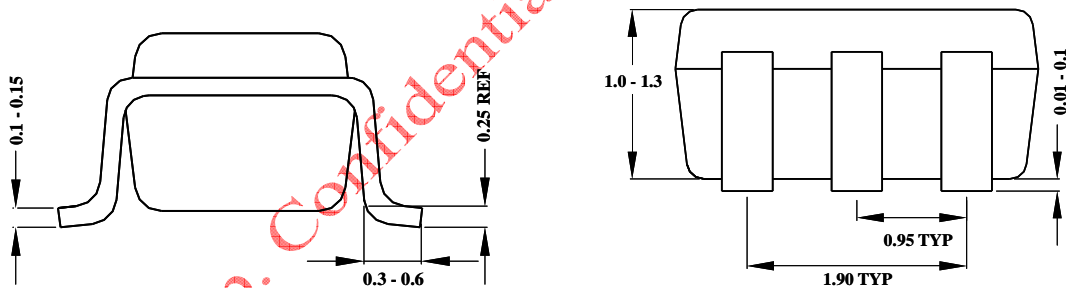

Notes: All dimensions are in millimeters.
All dimensions don't include mold flash & metal burr.

SO8 Package outline & PCB layout design

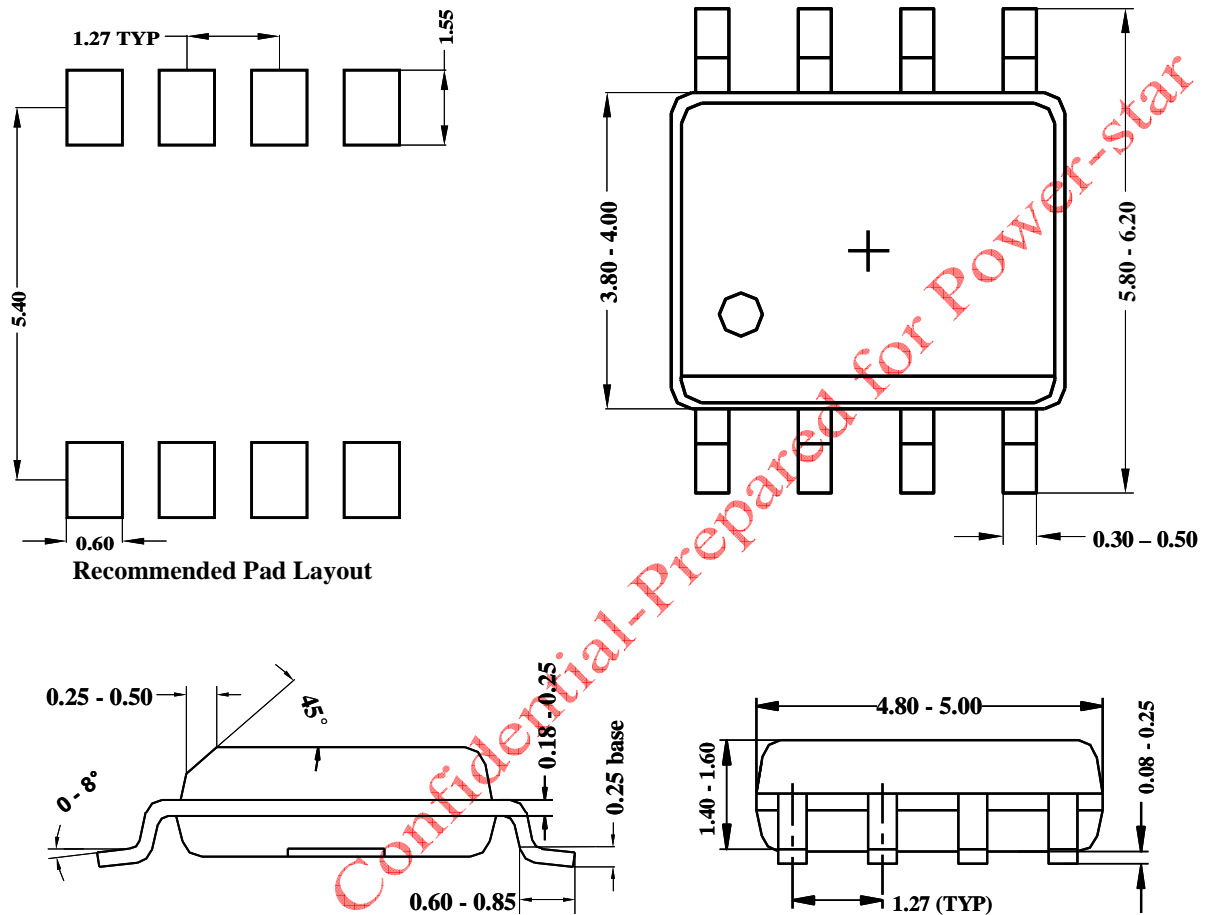

Notes: All dimensions are in millimeters.
All dimensions don't include mold flash & metal burr.

MSOP8 Package outline & PCB layout

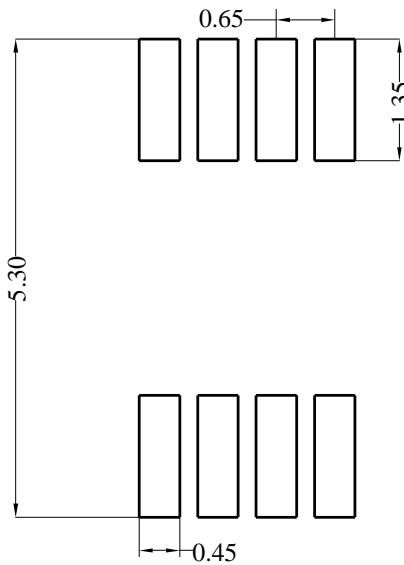

Recommended Pad Layout

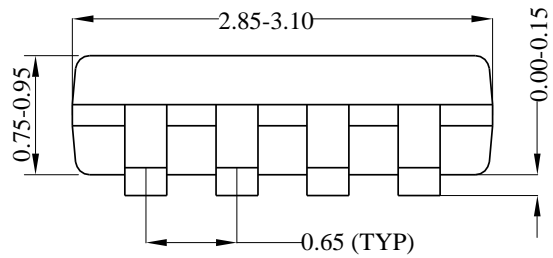
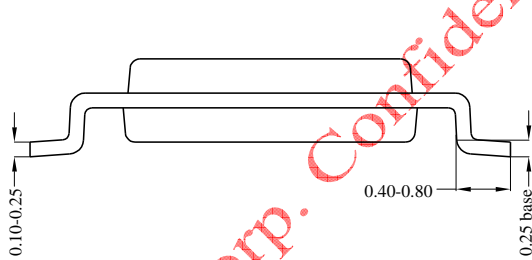
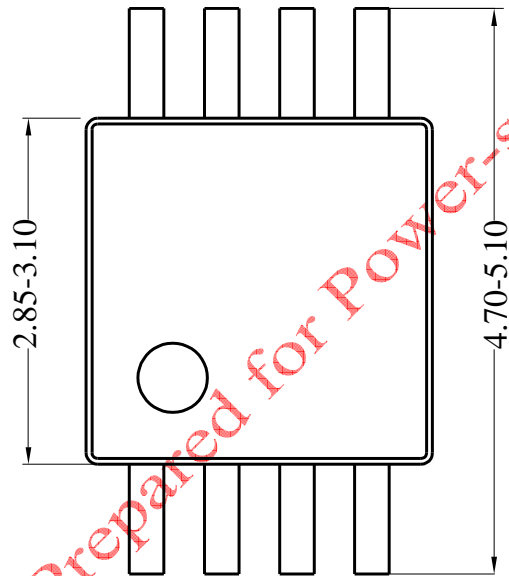

Notes: All dimensions are in millimeters.
All dimensions don't include mold flash & metal burr.

单击下面可查看定价，库存，交付和生命周期等信息

[>>SILERGY\(矽力杰\)](#)