



P-Channel MOSFET, -30V, -4.3A, 53mΩ

General Description

The VAT03R0530TF utilizes the advanced Trench technology and low resistance package to achieve extremely low on-resistance device which makes the system design an efficient and reliable solution for use in a wide variety of applications.

Features

- -30V, -4.3A, $R_{DS(on)}=53m\Omega@V_{GS}=-10V$
- High Efficiency
- Improved dv/dt, di/dt capability
- 100% EAS Guaranteed
- Green Device

Application

Mother Board, VGA, SMPS

Product Summary

$V_{DS}@T_{j,max}$	-30 V
$R_{DS(on)}@V_{GS}=-10V$	53mΩ
I_D Continuous Current	-4.3 A

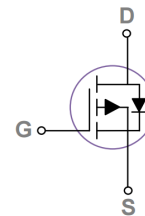
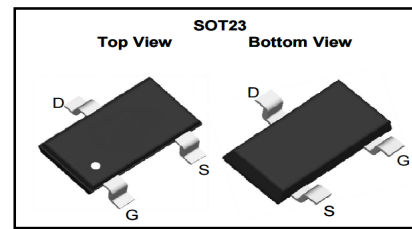

Absolute Maximum Ratings

Parameter	Symbol	Value	Unit	Condition
Drain-Source Voltage	V_{DS}	-30	V	
Continuous drain current ⁽¹⁾	I_D	-4.3 -3.6	A	$T_C=25^\circ C$ $T_C=70^\circ C$
Gate-Source Voltage	V_{GS}	± 12	V	Static
Pulsed drain current ⁽²⁾	I_{DM}	-20	A	$T_C=25^\circ C$
Power dissipation @ $T_C=25^\circ C$	P_{diss1}	1.4	W	$T_C=25^\circ C$
Power dissipation @ $T_C=70^\circ C$	P_{diss2}	0.9	W	$T_C=70^\circ C$
Continuous diode forward current	I_S	-4.3	A	$T_C=25^\circ C$
Storage Temperature Range	T_{STG}	-55 to 150	$^\circ C$	
Operation Junction Temperature Range	T_J	-55 to 150	$^\circ C$	

(1) Limited by $T_{j,max}$.

(2) Pulse width T_P limited by $T_{j,max}$



Thermal characteristics

Symbol	Parameter	Min	Typ	Max	Unit
R_{thJA}	Thermal resistance, junction-ambient	---	---	125	°C/W
T_{sold}	Soldering temperature	---	---	260	°C

Package and Ordering Information

Device	Package
VAT03R0530TF	SOT23



Electrical Characteristics ($T_j=25^\circ\text{C}$, unless otherwise specified)

Parameter	Symbol	Min	Typ	Max	Unit	Test Condition
Static Characteristic						
Drain-Source breakdown Voltage	$V_{(BR)DSS}$	-30	---	---	V	$V_{GS}=0V, I_D=-0.25mA$
Gate Threshold Voltage	$V_{(GS)th}$	-0.7	-1.0	-1.3	V	$V_{DS}=V_{GS}, I_D=-0.25mA$
Drain-Source on resistance	$R_{(DS)on}$	---	---	53	m Ω	$V_{GS}=-10V, I_D=-3A, T_j=25^\circ\text{C}$
		---	---	60	m Ω	$V_{GS}=-4.5V, I_D=-3A, T_j=25^\circ\text{C}$
		---	---	80	m Ω	$V_{GS}=-2.5V, I_D=-2A, T_j=25^\circ\text{C}$
Zero gate voltage drain current	I_{DSS}	---	---	1	μA	$V_{DS}=-24V, V_{GS}=0V, T_j=25^\circ\text{C}$
Gate-Source leakage current	I_{GSS}	---	---	100	nA	$V_{GS}=\pm 12V, V_{DS}=0V$
Dynamic Characteristic						
Input Capacitance	C_{iss}	---	920	---	pF	$V_{GS}=0V, V_{DS}=15V, f=1MHz$
Output Capacitance	C_{oss}	---	73	---	pF	$V_{GS}=0V, V_{DS}=15V, f=1MHz$
Turn-on delay time	$T_{d(on)}$	---	6.6	---	nS	$V_{DD}=15V, V_{GS}=4.5V, I_D=3A,$ $R_G=3.3\Omega;$
Rise time	T_r	---	27.8	---	nS	
Turn-off delay time	$T_{d(off)}$	---	46.2	---	nS	
Fall time	T_f	---	20.6	---	nS	
Gate Charge Characteristic						
Gate to source charge	Q_{gs}	---	1.8	---	nC	$V_{DD}=-15V, I_D=-3A, V_{GS}=-4.5V$
Gate to drain charge	Q_{gd}	---	3	---	nC	
Gate charge total	Q_g	---	11.9	---	nC	
Reverse diode characteristic						
Diode forward voltage	V_{FD}	---	---	-1.2	V	$V_{GS}=0V, I_F=1A, T_j=25^\circ\text{C}$
Continuous Source Current	I_{csc}	---	---	-4.3	A	$V_G=V_D=0V, \text{Force current}$
Pulsed Source Current	I_{sm}	---	---	-16	A	



Electrical Characteristic Diagrams

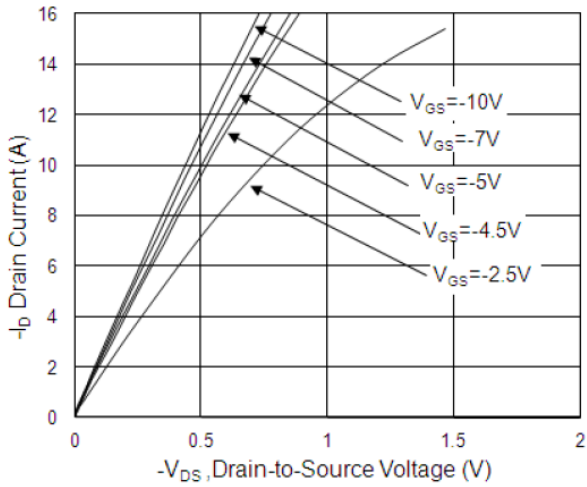

Figure 1 Typical Output Characteristic

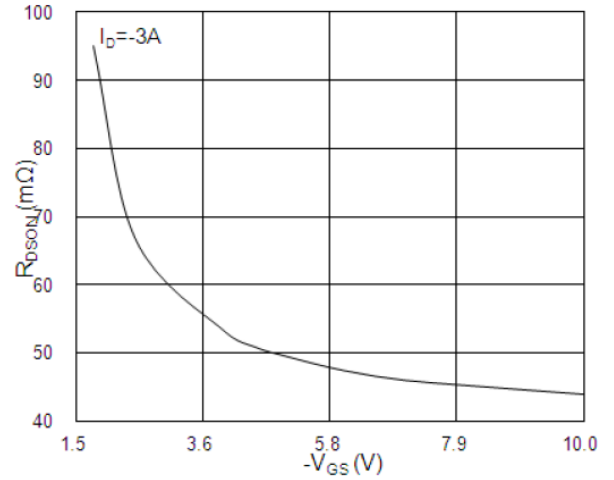

Figure 2 On-Resistance vs. GS voltage

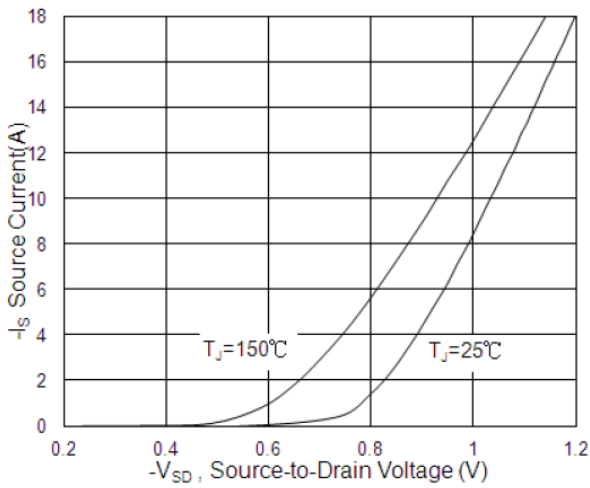

Figure 3 Forward Characteristic of Reverse

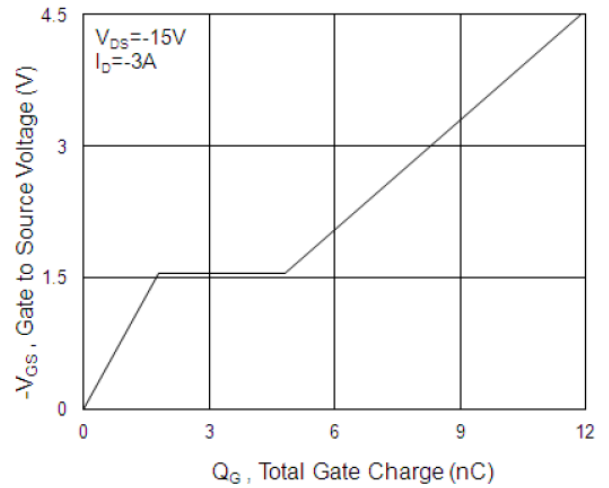

Figure 4 Gate Charge Waveform

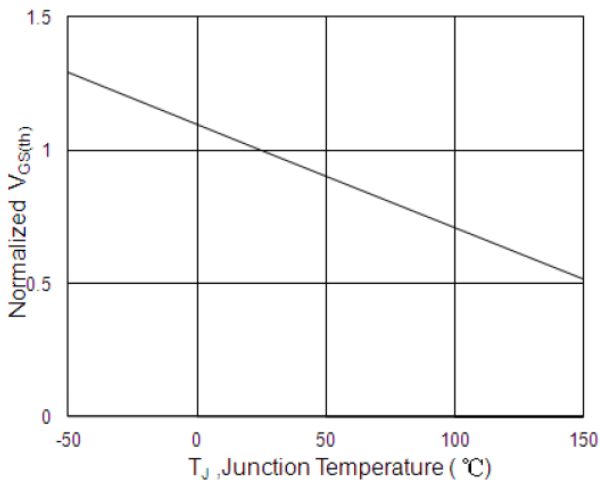

Figure 5 Normalized $V_{GS(th)}$ vs. T_J

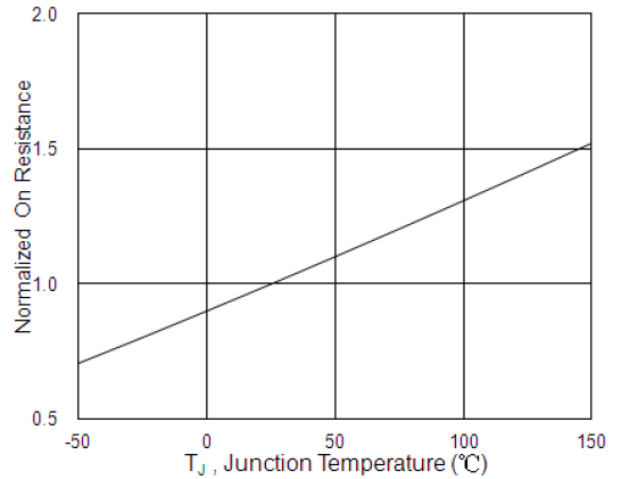

Figure 6 Normalized $R_{ds(on)}$ vs. T_J

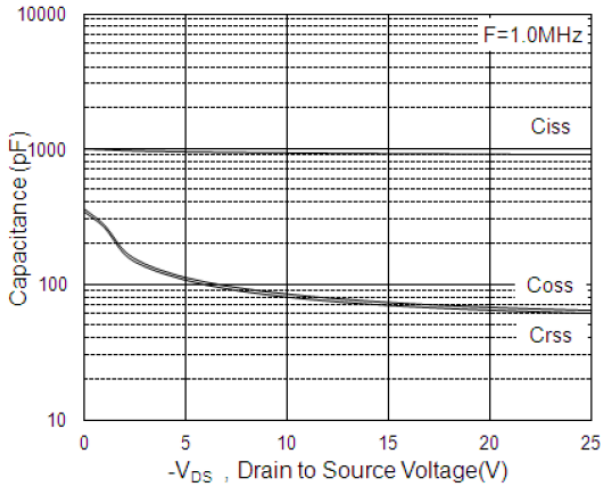

Figure 7 Capacitance Characteristic

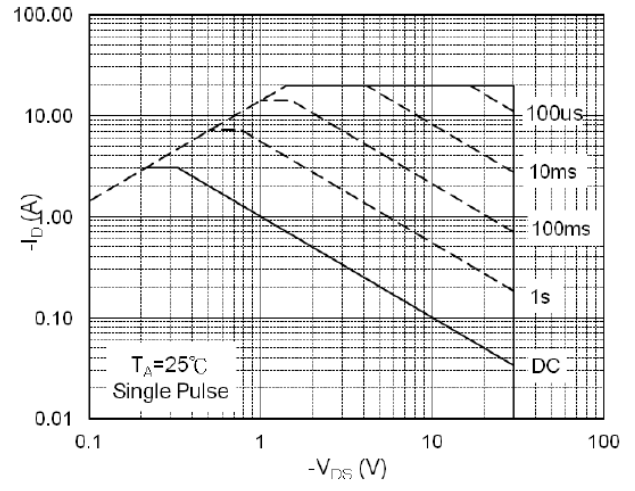

Figure 8 Safe Operating Area

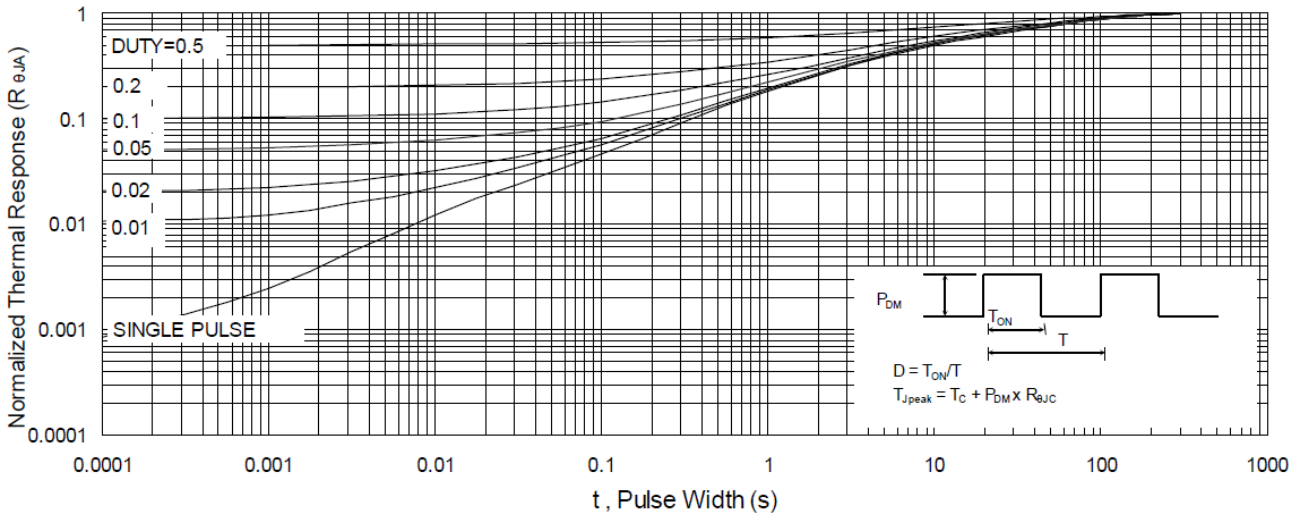

Figure 9 Normalized Maximum Transient Thermal Impedance

Parameter Test Circuits

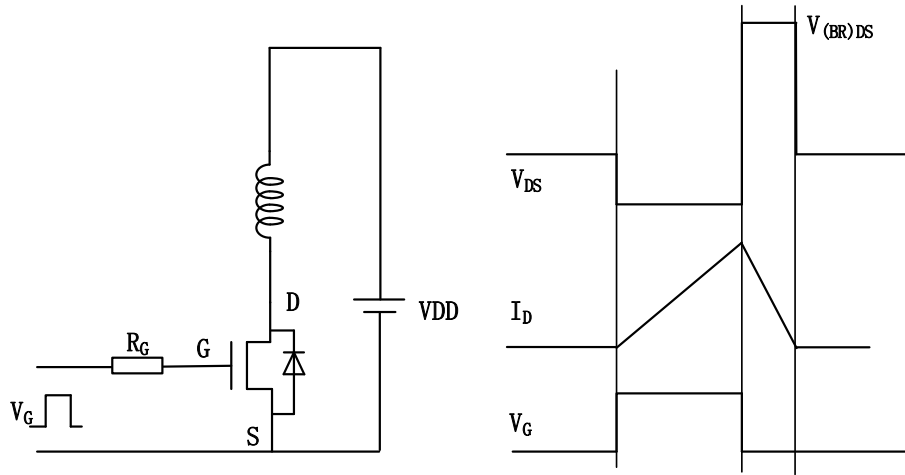

Figure 10 Unclamped Inductive Switching (UIS) Test circuit and waveforms

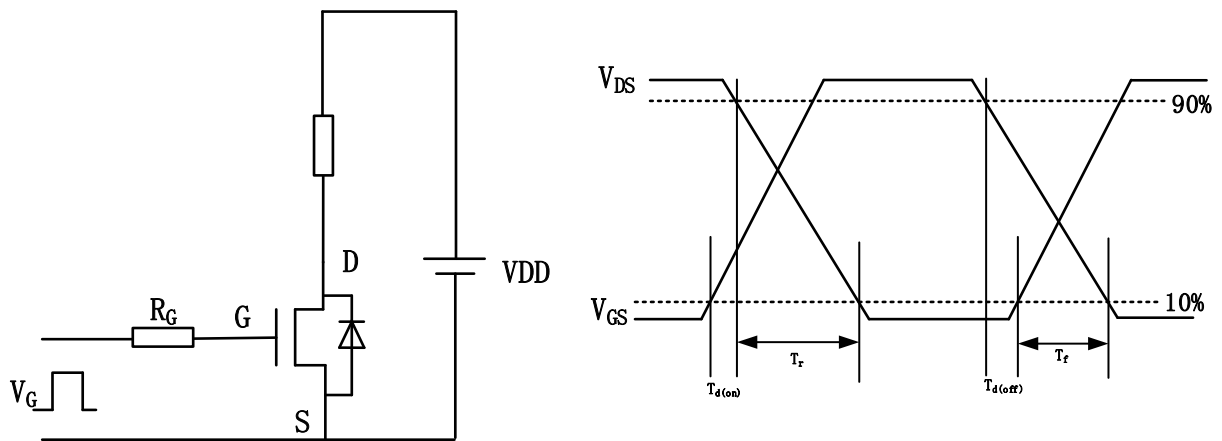

Figure 11 Resistive Switching time Test circuit and waveforms

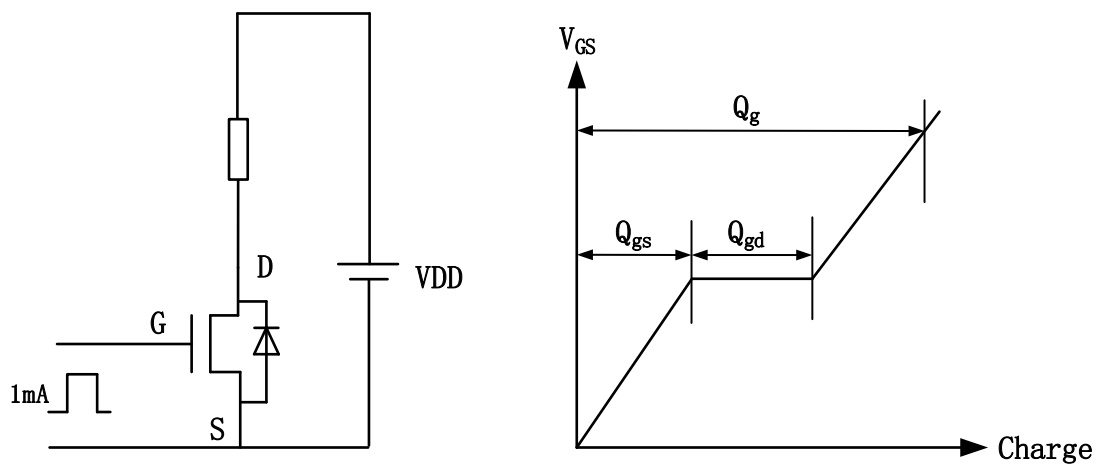
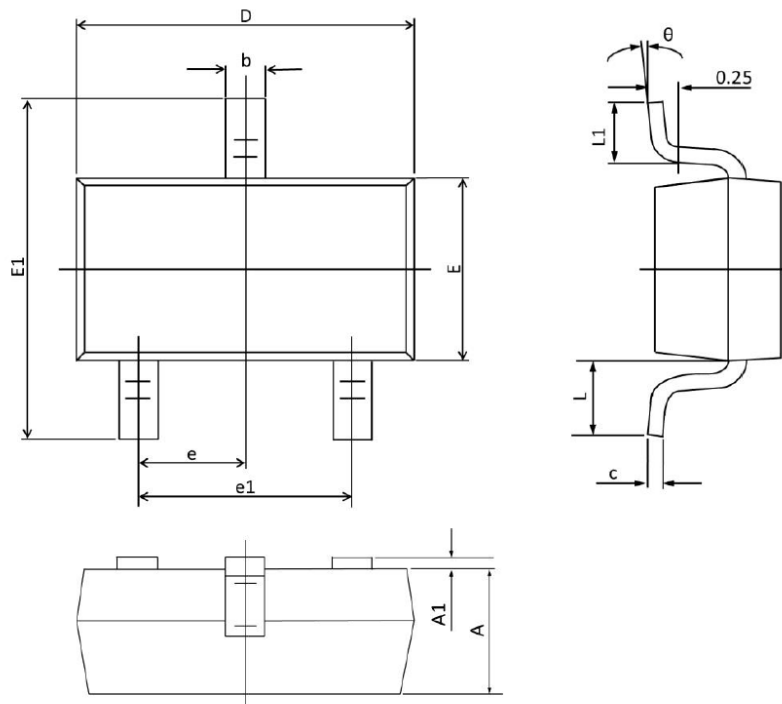

Figure 12 Gate charge Test circuit and waveforms



Package Information



Symbol	Dimensions In Millimeters		Dimensions In Inches	
	Min	Max	Min	Max
A	0.900	1.000	0.035	0.039
A1	0.000	0.100	0.000	0.004
b	0.300	0.500	0.012	0.020
c	0.090	0.110	0.003	0.004
D	2.800	3.000	0.110	0.118
E	1.200	1.400	0.047	0.055
E1	2.250	2.550	0.089	0.100
e	0.950 TYP.		0.037 TYP.	
e1	1.800	2.000	0.071	0.079
L	0.550 REF.		0.022 REF.	
L1	0.300	0.500	0.012	0.020
θ	1°	7°	1°	7°

单击下面可查看定价，库存，交付和生命周期等信息

[>>Chiplead\(奇力科技\)](#)