



APPROVAL SHEET

Customer Information

Customer :			
Part Name :			
Part No. :			
Model No. :			
	COMPANY	PURCHASE	R&D

Vendor Information

Name:	SFI ELECTRONICS TECHNOLOGY INC.
Part Name	Chip TVS
Part No.	SFI0603ML330C-LF
Lot No.	

SFI ELECTRONICS TECHNOLOGY INC.			
ADDRESS : No.6, Lane 340, Shan-Ying Road , Guishan,Tao Yuan Taiwan			
TEL: 886-3-3506998 FAX: 886-3-3507689 E-mail: sfi@sfi.com.tw			
Quality Control	Document Control	Business Issue	
 ISO 9001:2000 ISO 14001:2004	REV : H	Prepared	Check
			

Part No. :	SFI0603ML330C-LF	Document No.	AS-RD0603MC059-LF	REV.	H
http://www.sfi.com.tw E-mail : sfi@sfi.com.tw TEL:886-3-3506998 FAX :886-3-3507689 - 1 -					



PART NO. SFI0603ML330C-LF

1.1 Technology Data

	Symbol	Value	Unit
Maximum allowable continuous AC voltage at 50-60 Hz	V_{RMS}	20	V
Maximum allowable continuous DC voltage	V_{DC}	26	V
Varistor voltage measured	V_V	29.7~36.3	V
Maximum clamping voltage	V_{CLAMP} <	54	V
Maximum Peak Current	I_{Peak}	30	A

1.2 Reference Data

Maximum Energy Absorption* ₄	E	>	0.1	J
Typical capacitance value measured at 1K Hz	C		130	pF
Response time	T_{rise}	<	1	ns
Leakage current at $V_V \times 80\%$	I_{VV}	<	50	uA
Leakage current at $V_V \times 80\%$ (After reality Test)	I_{VVA}	<	200	uA
Operation ambient temperature			-50~ +85	°C
Storage temperature			-50~+125	°C

1.3 Other Data

Body			ZnO	
End termination			Ag/Ni/Sn	
Packaging			Reel	
Complies with Standard			IEC61000-4-5	
Complies with RoHs Standard			Yes	
Lead Content		<	1000	ppm
Marking			None	

Notes :

- * 1 The varistor voltage was measured at 1 mA current.
- * 2 The Clamping voltage was measured at 8*20 us standard current.
- * 3 The Leakage current was measured working voltage.
- * 4 The Energy only for customer reference.
- * 5 The components shall be employed within 1 year, in the nitrogen condition.

Part No. :	SFI0603ML330C-LF	Document No.	AS-RD0603MC059-LF	REV.	H
http://www.sfi.com.tw E-mail : sfi@sfi.com.tw TEL:886-3-3506998 FAX :886-3-3507689					- 2 -



2. Size

Model	0402(1005)	0603(1608)	0805(2012)	1206(3216)	1210(3225)	1812(4532)	2220(5750)
Length(L)	1.00 ±0.10	1.60±0.15	2.00±0.20	3.20±0.20	3.20±0.20	4.50±0.20	5.70±0.20
Width(W)	0.50 ±0.10	0.80±0.10	1.25±0.15	1.60±0.15	2.50±0.20	3.20±0.20	5.00±0.20
Thickness(T)	0.60 max	0.90 max	1.20 max	1.50 max	1.50 max	2.00 max	2.50 max
Termination(a)	0.25±0.1	0.3±0.1	0.4±0.2	0.5±0.2	0.5±0.2	0.5+0.3/-0.1	0.5+0.3/-0.1

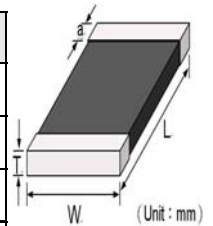

3. Surge Wave Form

Wave shape "Short circuit" (Current I_{sc})

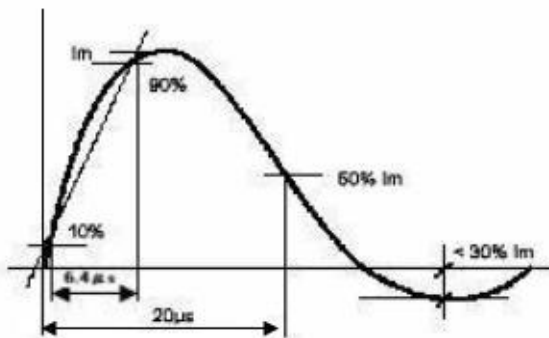

IEC61000-4-5 Standards

SEVERITY LEVEL	T1	T2
1	8 μs	20 μs
2	10 μs	1000 μs

8/20 μs waveform current (A)

4. Environment Reliability Test

Characteristic	Test method and description		
High Temperature Storage	The specimen shall be subjected to $125 \pm 2^\circ\text{C}$ for 1000 ± 12 hours in a thermostatic bath without load and then stored at room temperature and normal humidity for 1 to 2 hours. The change of varistor voltage shall be within 10 % .		
Temperature Cycle	The temperature cycle of specified temperature shall be repeated five times and then stored at room temperature and normal humidity for one or two hours. The change of varistor voltage shall be within 10 % and mechanical damage shall be examined.	Step	Temperature
		1	$-40 \pm 3^\circ\text{C}$
		2	Room Temperature
		3	$125 \pm 3^\circ\text{C}$
4	Room Temperature	1 hour	
High Temperature Load	After being continuously applied the maximum allowable voltage at $85 \pm 2^\circ\text{C}$ for 1000 ± 2 hours, the specimen shall be stored at room temperature and normal humidity for one or two hours, the change of varistor voltage shall be within 10% .		
Damp Heat Load/ Humidity Load	The specimen should be subjected to $40 \pm 2^\circ\text{C}$, 90 to 95 % RH environment, and the maximum allowable voltage applied for 1000 hours, then stored at room temperature and normal humidity for one or two hours. The change of varistor voltage shall be within 10%		
Low Temperature Storage	The specimen should be subjected to $-40 \pm 2^\circ\text{C}$, without load for 500 hours and then stored at room temperature for one or two hours. The change of varistor voltage shall be within 10 %		

Part No. :	SF10603ML330C-LF	Document No.	AS-RD0603MC059-LF	REV.	H
http://www.sfi.com.tw		E-mail : sfi@sfi.com.tw		TEL:886-3-3506998	FAX :886-3-3507689

5. Soldering Recommendations

5.1 Recommended solder pad layout

(Unit : mm)

	A	B	C	D
0402	0.4~0.6	1.4~1.8	0.5~0.6	0.6~1.2
0603	0.9~1.2	2.7~3.2	0.7~1.0	0.9~1.2
0805	1.0~1.5	2.6~3.2	1.2~1.5	1.1~1.8
1206	1.8~2.5	4.2~5.2	1.2~1.8	1.2~1.8
1210	1.8~2.5	4.2~5.2	2.2~3.0	1.3~2.0
1812	2.5~3.3	5.5~6.7	2.8~3.6	1.3~2.2
2220	3.8~4.6	6.6~7.8	4.8~5.5	1.3~2.2

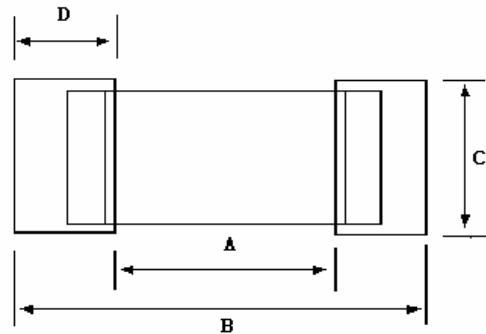

5.2 The SIR test of the solder paste shall be done (Based on JIS-Z-3284)

5.3 Steel plate and foot distance printing

Foot distance printing (mm)	Steel Plate thickness (mm)
> 0.65mm	0.18mm
0.65mm~0.5mm	0.15mm
0.50mm~0.40mm	0.12mm
>=0.40 mm	0.10mm

5.4 The IR reflow and temperature of Soldering for Pb Free

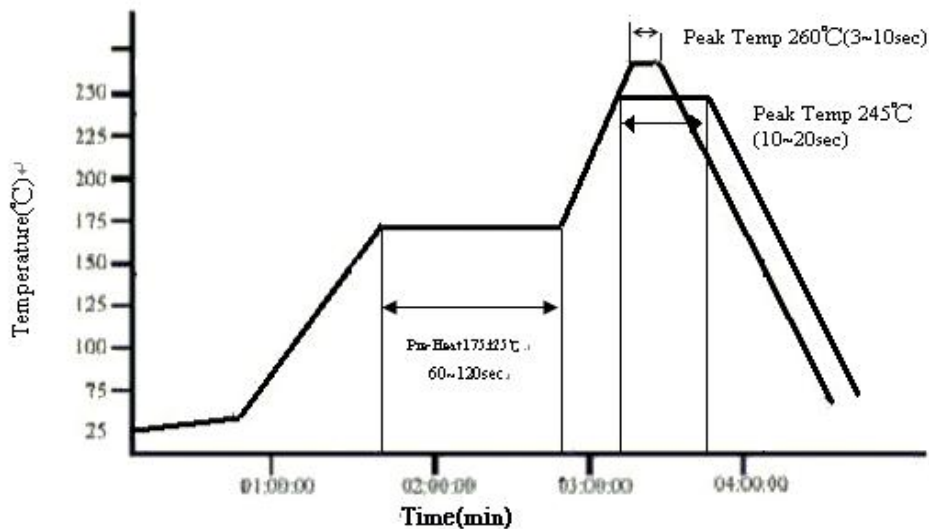

☆ IR reflow Pb Free Process suggestion profile

- (1) The solder recommend is Sn96.5/Ag 3.5 of 120 to 150 μ m
- (2) Ramp-up rate (217°C to Peak) + 3°C/second max
- (3) Temp. maintain at 175 +/-25°C 180 seconds max
- (4) Temp. maintain above 217 °C 60-150 seconds

Part No. :	SF10603ML330C-LF	Document No.	AS-RD0603MC059-LF	REV.	H
http://www.sfi.com.tw E-mail : sfi@sfi.com.tw TEL:886-3-3506998 FAX :886-3-3507689 - 4 -					



- (5) Peak temperature range 245°C +20°C/ -10 °C time within 5 °C of actually peak temperature (tp) 10~20 seconds
- (6) Ramp down rate +6 °C/second max.

※Perform adequate test in advance as the reflow temperature profile will vary according to the conditions of the manufacturing process, and the specification of the reflow furnace.

5.5 Resistance to soldering heat-High Temperature Resistance:260°C ,10sec-3times.

5.6 Hand Soldering

In hand soldering of the Varistors. Large temperature gradient between preheated the Varistors and the tip of soldering iron may cause electrical failures and mechanical damages such as crackings or breakings of the devices. The soldering shall be carefully controlled and carried out so that the temperature gradient is kept minimum with following recommended conditions for hand soldering.

5.6.1 Recommended Soldering Condition 1

- (1) Solder :
0.12~0.18mm Thread solder (Sn96.5:Ag3.5) with soldering flux in the core.
Rosin-based and non-activated flux is recommended.
- (2) Preheating
The Varistors shall be preheated so that Temperature Gradient between the devices and the tip of soldering iron is 150°C or below.
- (3) Soldering Iron
Rated Power of 20w max with 3mm soldering tip in diameter.
Temperature of soldering iron tip 380°C max,3-5sec (The required amount of solder shall be melted in advance on the soldering tip.)
- (4) Cooling
After soldering. The Varistors shall be cooled gradually at room ambient temperature.

5.6.2 Recommended Soldering Condition 2 (Without preheating)

- (1) Solder iron tip shall not directly touch to ceramic dielectrics.
- (2) Solder iron tip shall be fully preheated before soldering while soldering iron tip to the external electrode of Varistors.

5.7 Post Soldering Cleaning

5.7.1 Residues of corrosive soldering fluxes on the PC board after cleaning may greatly have influences on the electrical characteristic and the reliability (such as humidity resistance)of the Varistors which have been mounted on the board. It shall be confirmed that the characteristic and the reliability of the devices are not affected by the applied cleaning conditions.

5.7.2. When an ultrasonic cleaning is applied to the mounted Varistors on PC Boards. Following conditions are recommended for preventing failures or damages of the devices due to the large vibration energy and the resonance caused by the ultrasonic waves.

- (1) Frequency 29MHz max
- (2) Radiated Power 20w/lithr max
- (3) Period 5minuets max

Part No. :	SF10603ML330C-LF	Document No.	AS-RD0603MC059-LF	REV.	H
http://www.sfi.com.tw E-mail : sfi@sfi.com.tw TEL:886-3-3506998 FAX :886-3-3507689 - 5 -					

6. Packaging Specification

6.1 Carrier tape and transparent cover tape should be heat-sealed to carry the products, and the reel should be used to reel the carrier tape.

6.2 The adhesion of the heat-sealed cover tape shall be $40 + 20 / - 15$ grams.

6.3 Both the head and the end portion of the taping shall be empty for reel package and SMT auto-pickup machine. And a normal paper tape shall be connected in the head of taping for the operator to handle.

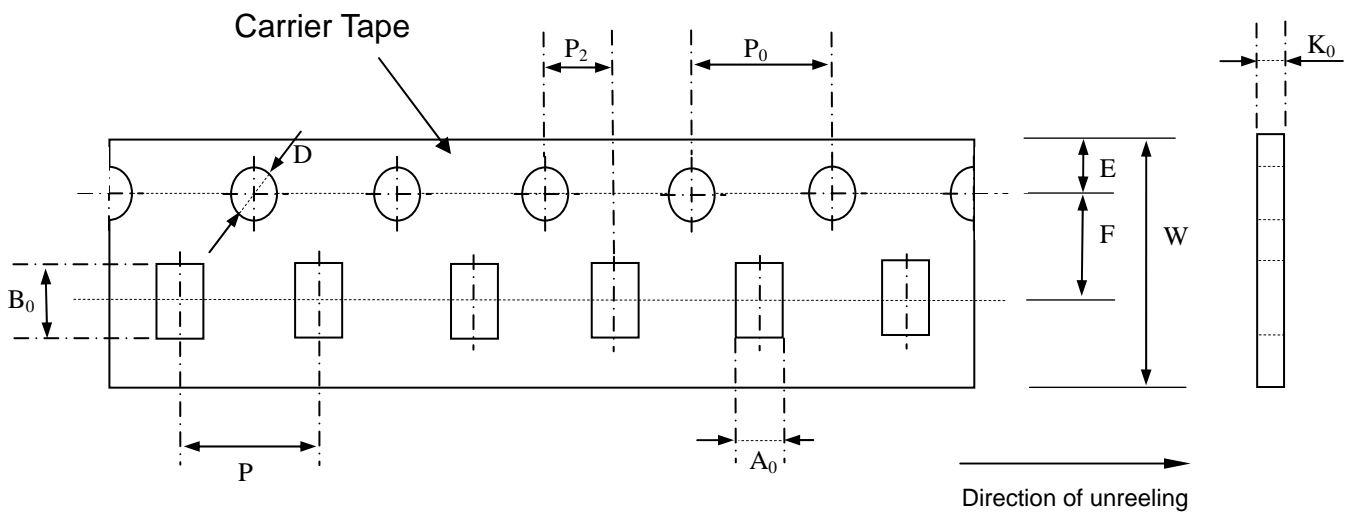

Symbol	A_0 ± 0.05	B_0 ± 0.05	K_0 ± 0.05	D $+0.10$ -0.05	P ± 0.10	P_2 ± 0.10	P_0 ± 0.10	W ± 0.10	E ± 0.10	F ± 0.05
0402	0.62	1.12	0.60	1.55	2.00	2.00	4.00	8.00	1.75	3.50
0603	1.10	1.90	0.95	1.56	4.00	2.00	4.00	8.00	1.75	3.50

Part No. :	SF10603ML330C-LF	Document No.	AS-RD0603MC059-LF	REV.	H
http://www.sfi.com.tw E-mail : sfi@sfi.com.tw TEL:886-3-3506998 FAX :886-3-3507689 - 6 -					

7. Reel Dimension

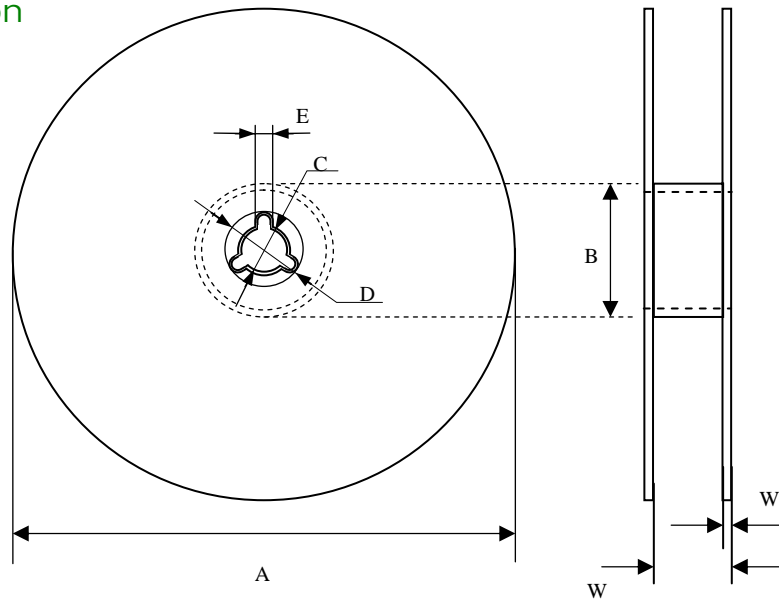

Symbol	A	B	C	D	E	W	W ₁
0402	178.0±1.0	60.0±0.5	13.0±0.2	21.0±0.2	2.0±0.5	9.0±0.50	1.5±0.15
0603	178.0±1.0	60.0±0.5	13.0±0.2	21.0±0.2	2.0±0.5	9.0±0.50	1.5±0.15
0805	178.0±1.0	60.0±0.5	13.0±0.2	21.0±0.2	2.0±0.5	9.0±0.50	1.5±0.15
1206	178.0±1.0	60.0±0.5	13.0±0.2	21.0±0.2	2.0±0.5	9.0±0.50	1.5±0.15
1210	178.0±1.0	60.0±0.5	13.0±0.2	21.0±0.2	2.0±0.5	9.0±0.50	1.5±0.15
1812	178.0±1.0	60.0±0.5	13.5±0.1	21.0±0.2	2.0±0.5	13.6±0.2	1.5±0.15
2220	178.0±1.0	60.0±0.5	13.5±0.1	21.0±0.2	2.0±0.5	13.6±0.2	1.5±0.15

8. Standard Packaging

Size	0402	0603	0805	1206	1210	1812	2220
Pcs	10000	4000	3000	3000	2000	1000	1000

Part No. :	SF10603ML330C-LF	Document No.	AS-RD0603MC059-LF	REV.	H
http://www.sfi.com.tw E-mail : sfi@sfi.com.tw TEL:886-3-3506998 FAX :886-3-3507689 - 7 -					

单击下面可查看定价，库存，交付和生命周期等信息

[>>SFI\(台湾立昌\)](#)