

THIS DRAWING IS UNPUBLISHED. RELEASED FOR PUBLICATION
 © COPYRIGHT - By - ALL RIGHTS RESERVED.

LOC	DIST	REVISIONS			
P	LTR	DESCRIPTION	DATE	DWN	APVD
GP	00				
	K2	REVISED PER ECO-11-017434	19DEC2011	CJV	CWR

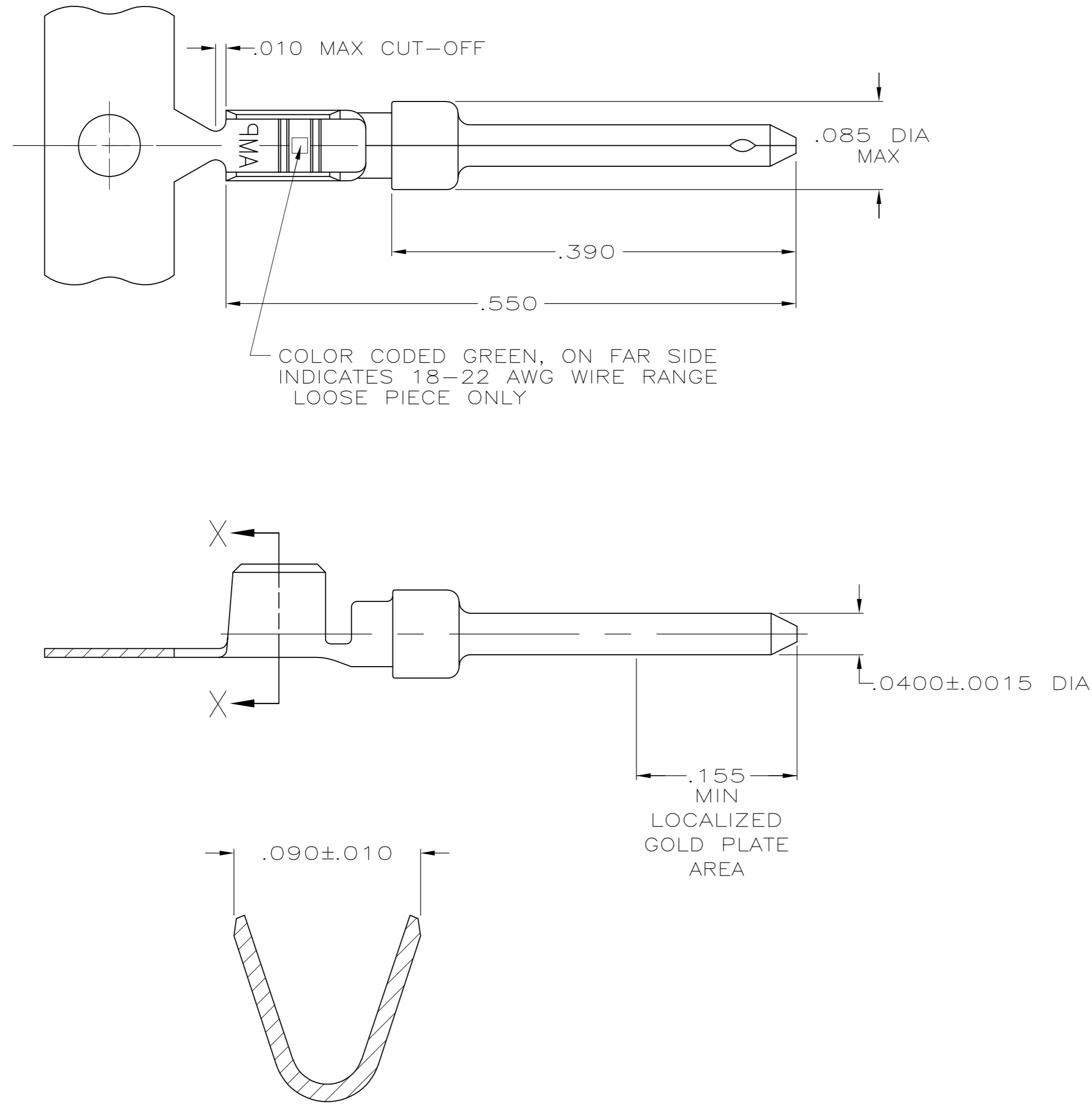

SECTION X-X
 WIRE BARREL
 SCALE 20:1

- 1 FOR MINI-APPLICATOR.
- 2 FOR HAND TOOL USE ONLY.
- 3. WIRE RANGE OF 18-22 AWG.
- 4. .068 MAX INSULATION DIAMETER ALLOWABLE WHEN USING 91067-2 EXTRACTION TOOL.
- 5. GOLD PLATING MAY NOT APPEAR ON CARRIER STRIP.
- 6 GOLD PLATING PER MIL-G-45204.
 NICKEL PLATING PER QQ-N-290.
 TIN PLATING PER MIL-T-10727.
- 7 GOLD PLATED IN LOCALIZED GOLD PLATE AREA AS FOLLOWS:
 .000030 MIN GOLD IN MATED AREA,
 GOLD FLASH ON REMAINDER OF CONTACT, ALL OVER .000050
 MIN NICKEL UNDERPLATE.
 OR
 GOLD FLASH OVER
 PALLADIUM-NICKEL PLATE, .000030 MIN TOTAL IN MATED AREA,
 GOLD FLASH ON REMAINDER OF CONTACT, ALL OVER
 .000050 MIN NICKEL UNDERPLATE.
- 8 PLATED WITH GOLD FLASH OVER
 .000050 MIN NICKEL.
- 9 PLATED WITH GOLD FLASH IN LOCALIZED GOLD PLATE AREA,
 TIN PLATED WIRE BARREL, OVER
 .000030 NICKEL.
- 10 GOLD PLATED IN LOCALIZED GOLD PLATE AREA
 .000030 GOLD IN MATED AREA,
 TIN PLATED WIRE BARREL, OVER
 .000050 NICKEL.
- 11 OBSOLETE.
- 12 SUPERSEDED BY 745229-4

10	11-745229-3	11-745229-1
9	11-745229-0	11-745229-8
8	745229-7	745229-5
7	745229-4	745229-2
FINISH	LOOSE PIECE 2	PART NUMBER 1

DIMENSIONS:		TOLERANCES UNLESS OTHERWISE SPECIFIED:		MATERIAL		FINISH	
INCHES		0 PLC	± -	BRASS PER MIL-C-50	SEE TABLE	0	± -
		1 PLC	± -			1	± -
		2 PLC	± -			2	± -
		3 PLC	± .005			3	± -
		4 PLC	± -			4	± -
		ANGLES	± -				± -

THIS DRAWING IS A CONTROLLED DOCUMENT.		DWN	S. WELDON	9-9-86
		CHK	C. RICHARD	9-9-86
		APVD	V. KUMAR	9-10-86
		PRODUCT SPEC		
		APPLICATION SPEC	114-10000	
		WEIGHT	-	
		CUSTOMER DRAWING		

NAME		TE Connectivity	
PIN CONTACT, SIZE 20 DF, 18-22 AWG, .068 MAX INSULATION DIA			
SIZE	CAGE CODE	DRAWING NO	RESTRICTED TO
A2	00779	C-745229	-
SCALE	SHEET	1 OF 1	REV
10:1	1		K2

单击下面可查看定价，库存，交付和生命周期等信息

[>>TE Connectivity\(泰科\)](#)

[>>点击查看相关商品](#)