



# Approval Sheet

## Customer Information

Customer :		
Part Name :		
Part No. :		
Model No. :		
<b>Company</b>	<b>Purchase</b>	<b>R&amp;D</b>



## Vendor Information

Name:	SFI ELECTRONICS TECHNOLOGY INC.
Part Name	Chip Surge Protection Device (CSPD) Series
Part No.	Super High Current (SHC) Device - SFI1206SC750-501A
Lot No.	

## SFI Electronics Technology INC.

ADDRESS : No.6, Lane 340, Shan-Ying Road , Guishan,Tao Yuan Taiwan

TEL: 886-3-3506998 FAX: 886-3-3507689 E-mail: sfi@sfi.com.tw

Quality Control	Document Control	Business Issue	
 ISO 9001:2008 ISO TS16949:2009 ISO 14001:2004	REV : C	Prepared	Check
			

Part No. :	<b>SFI1206SC750-501A</b>	Document No.	<b>AS-RD1206MA183-LF</b>	REV.	<b>C</b>
<a href="http://www.sfi.com.tw">http://www.sfi.com.tw</a> E-mail : <a href="mailto:sfi@sfi.com.tw">sfi@sfi.com.tw</a> TEL:886-3-3506998 FAX :886-3-3507689 - 1 -					



## PART NO. SFI1206SC750-501A

1.1 Technology Data	Symbol	Value	Unit
Maximum allowable continuous AC voltage at 50-60 Hz	$V_{RMS}$	48	V
Maximum allowable continuous DC voltage	$V_{DC}$	60	V
Breakdown voltage measured	$V_V$	75(±10%)	V
Maximum clamping voltage	$V_{CLAMP}$ <	100	V
Maximum Peak Current (8/20µs)	$I_{Peak}$	500	A

1.2 Reference Data	Symbol	Value	Unit
Typical capacitance value measured at 1K Hz	C	800	pF
Response time	$T_{rise}$ <	1	ns
Non-linear coefficient	$\alpha$ >	30	
Leakage current at $V_V \times 80\%$	$I_{VV}$ <	10	µA
Leakage current at $V_V \times 80\%$ (After surge Test)	$I_{VV A}$ <	80	µA
Operation ambient temperature		-55~+125	°C
Storage temperature		-55~+150	°C

1.3 Other Data	Symbol	Value	Unit
Body		Nano Special Ceramic	
End termination		Ag/Sn	
Packaging		Reel	
Complies with Standard		IEC61000-4-5 ITU-T K20, K21	
Complies with RoHs Standard		Yes	
Lead Content	<	1000	ppm
Marking		None	

Notes :

- \* 1 The breakdown voltage was measured at 1 mA current.
- \* 2 The Clamping voltage was measured at 8\*20 us standard current, 1206(1A).
- \* 3 The surge current was tested at 8/20 µs waveform.
- \* 4 The capacitance value only for customer reference, it's not formal specification.
- \* 5 The components shall be employed within 1 year, in the nitrogen condition.

Part No. :	<b>SFI1206SC750-501A</b>	Document No.	<b>AS-RD1206MA183-LF</b>	REV.	<b>C</b>
<a href="http://www.sfi.com.tw">http://www.sfi.com.tw</a> E-mail : <a href="mailto:sfi@sfi.com.tw">sfi@sfi.com.tw</a> TEL:886-3-3506998    FAX :886-3-3507689    - 2 -					

## 1.4 Features of SHC Series

1. RoHS compliant
2. SMD type Body size 1206
3. Meet IEC61000-4-5 / K21 Standard
4. Bidirectional and symmetrical V/I characteristics
5. Large withstanding surge current capability : 500A (@8/20 $\mu$ s)
6. Excellent low leakage current <10 $\mu$ A
7. Operating temperature range : -55 ~ +125 $^{\circ}$ C
8. Multi-Layers construction provides higher power dissipation

### Equivalent Circuit

- ☆L      **Body Inductance**
- ☆C      **Device Capacitance**
- ☆VR     **Voltage Variable Resistor**
- ☆R      **Insulation Resistor**
- ☆Diode **Voltage clamped**
- ☆PTC    **For low leakage current**

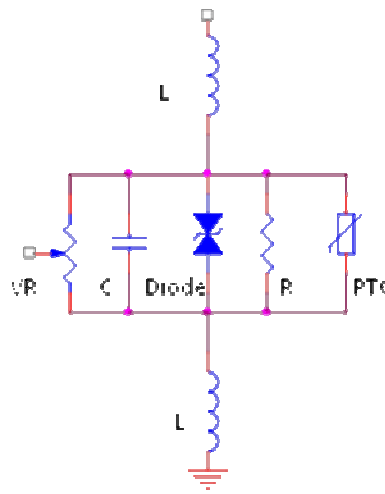

## 2. Size

Model	1206 Series
Length(L)	3.2 $\pm$ 0.2mm
Width(W)	1.67 $\pm$ 0.15mm
Thickness(T)	1.70 mm Max
Termination(a)	0.50 $\pm$ 0.2mm

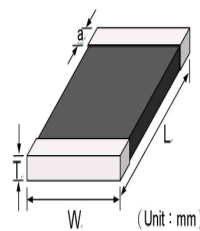

<b>Part No. :</b>	<b>SFI1206SC750-501A</b>	<b>Document No.</b>	<b>AS-RD1206MA183-LF</b>	<b>REV.</b>	<b>C</b>
<a href="http://www.sfi.com.tw">http://www.sfi.com.tw</a> E-mail : <a href="mailto:sfi@sfi.com.tw">sfi@sfi.com.tw</a> TEL:886-3-3506998    FAX :886-3-3507689    - 3 -					

### 3. Surge Wave Form

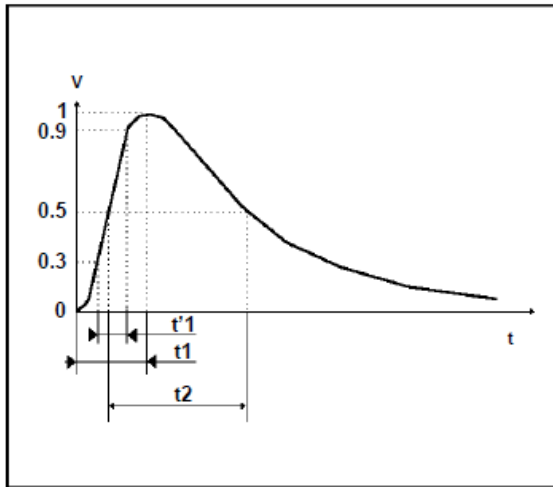

**8/20  $\mu$ s waveform current**

### IEC61000-4-5 Standards

SEVERITY LEVEL	t1 (=1.67t'1)	t2
1	8 $\mu$ s	20 $\mu$ s

### 4. Environmental Reliability Test

Item	Requirement	Test condition
High Temperature Storage	1. Breakdown voltage change : within $\pm 10\%$ 2. No mechanical damage	1. Temperature : $150 \pm 2^\circ\text{C}$ 2. Time : $1000 \pm 2$ hours 3. Test after placing in ambient temperature for 24 hours.
Low Temperature Storage	1. Breakdown voltage change : within $\pm 10\%$ 2. No mechanical damage	1. Temperature : $-40 \pm 2^\circ\text{C}$ 2. Time : $1000 \pm 2$ hours 3. Test after placing in ambient temperature for 24 hours.
Temperature Cycle	1. Breakdown voltage change : within $\pm 10\%$ 2. No mechanical damage	1. Step 1 : $-40 \pm 3^\circ\text{C}$ ; time : $30 \pm 3$ min 2. Step 2 : $25^\circ\text{C}$ ; time : 1 hour 3. Step 3 : $-125 \pm 3^\circ\text{C}$ ; time : $30 \pm 3$ min 4. Step 4 : $25^\circ\text{C}$ ; time : 1 hour 5. Number of cycle : 5 times 6. Test after placing in ambient temperature for 24 hours.
High Temperature Load	1. Breakdown voltage change : within $\pm 10\%$ 2. No mechanical damage	1. Temperature : $125 \pm 2^\circ\text{C}$ 2. Rated working voltage applied 3. Time : $1000 \pm 2$ hours 4. Test after placing in ambient temperature for 24 hours.
Damp Heat Load/ Humidity Load	1. Breakdown voltage change : within $\pm 10\%$ 2. No mechanical damage	1. Temperature : $40 \pm 2^\circ\text{C}$ 2. Humidity : 90~95% RH 3. Rated working voltage applied 4. Time : $500 \pm 2$ hours 5. Test after placing in ambient temperature for 24 hours.

Part No. :	<b>SFI1206SC750-501A</b>	Document No.	<b>AS-RD1206MA183-LF</b>	REV.	<b>C</b>
<a href="http://www.sfi.com.tw">http://www.sfi.com.tw</a> E-mail : <a href="mailto:sfi@sfi.com.tw">sfi@sfi.com.tw</a> TEL:886-3-3506998    FAX :886-3-3507689    - 4 -					

## 5. Soldering Recommendations

### 5.1 Recommended solder pad layout

(Unit : mm)

	A	B	C
1206	1.8~2.5	1.2~1.8	1.5~2.0

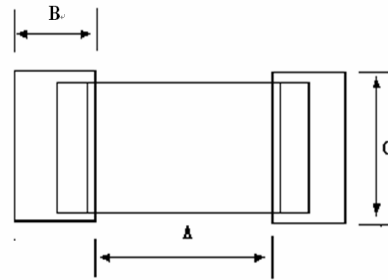

### 5.2 The SIR test of the solder paste shall be done (Based on JIS-Z-3284)

### 5.3 Steel plate and foot distance printing

Foot distance printing (mm)	Steel Plate thickness (mm)
> 0.65mm	0.18mm
0.65mm~0.5mm	0.15mm
0.50mm~0.40mm	0.12mm
<=0.40 mm	0.10mm

### 5.4 The IR Reflow and Temperature of Soldering for Pb Free

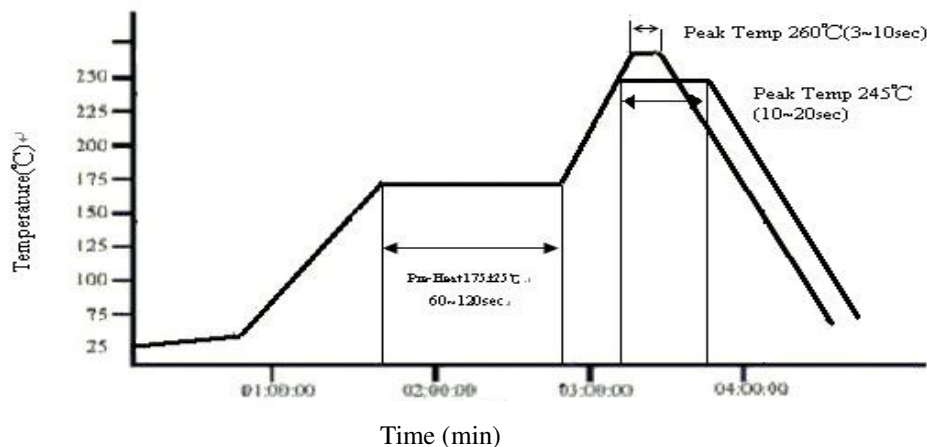

#### ☆ IR reflow Pb Free Process suggestion profile

- (1) The solder recommend is Sn96.5/Ag 3.5 of 120 to 150  $\mu$ m
- (2) Ramp-up rate (217°C to Peak) + 3°C/second max
- (3) Temp. maintain at 175 +/-25°C 180 seconds max
- (4) Temp. maintain above 217 °C 60-150 seconds
- (5) Peak temperature range 245°C +20°C/ -10 °C time within 5 °C of actually peak temperature 10~20 seconds
- (6) Ramp down rate +6 °C/second max.

※Perform adequate test in advance as the reflow temperature profile will vary according to the conditions of the manufacturing process, and the specification of the reflow furnace.

Part No. :	<b>SFI1206SC750-501A</b>	Document No.	<b>AS-RD1206MA183-LF</b>	REV.	<b>C</b>
<a href="http://www.sfi.com.tw">http://www.sfi.com.tw</a> E-mail : <a href="mailto:sfi@sfi.com.tw">sfi@sfi.com.tw</a> TEL:886-3-3506998 FAX :886-3-3507689 - 5 -					



### 5.5 Resistance to Soldering Heat-High Temperature Resistance:260,10sec- 3 times.

### 5.6 Hand Soldering

In hand soldering of the SHC devices. Large temperature gradient between preheated the SHC devices and the tip of soldering iron may cause electrical failures and mechanical damages such as crackings or breakings of the devices. The soldering shall be carefully controlled and carried out so that the temperature gradient is kept minimum with following recommended conditions for hand soldering.

#### 5.6.1 Recommended Soldering Condition 1

- (1) Solder :  
**0.12~0.18mm** Thread solder (Sn96.5:Ag3.5) with soldering flux in the core.  
Rosin-based and non-activated flux is recommended.
- (2) Preheating  
The SHC devices shall be preheated so that Temperature Gradient between the devices and the tip of soldering iron is 150°C or below.
- (3) Soldering Iron  
Rated Power of 20w max with 3mm soldering tip in diameter.  
Temperature of soldering iron tip 380°C max, 3-5sec ( The required amount of solder shall be melted in advance on the soldering tip.)
- (4) Cooling  
After soldering. The SHC devices shall be cooled gradually at room ambient temperature.

#### 5.6.2 Recommended Soldering Condition 2 ( Without preheating )

- (1) Solder iron tip shall not directly touch to ceramic dielectrics.
- (2) Solder iron tip shall be fully preheated before soldering while soldering iron tip to the external electrode of the SHC devices.

### 5.7 Recommended using IR Reflow Process. The Wave Soldering Process and Immersion Tin Process can't to be Adopted for this Product.

### 5.8 Post Soldering Cleaning

5.8.1 Residues of corrosive soldering fluxes on the PC board after cleaning may greatly have influences on the electrical characteristic and the reliability (such as humidity resistance)of the SHC devices which have been mounted on the board. It shall be confirmed that the characteristic and the reliability of the devices are not affected by the applied cleaning conditions.

5.8.2. When an ultrasonic cleaning is applied to the mounted SHC devices on PC Boards.

Following conditions are recommended for preventing failures or damages of the devices due to the large vibration energy and the resonance caused by the ultrasonic waves.

- (1) Frequency 29MHz max
- (2) Radiated Power 20w/lithr max
- (3) Period 5minuets max

Part No. :	<b>SFI1206SC750-501A</b>	Document No.	<b>AS-RD1206MA183-LF</b>	REV.	<b>C</b>
<a href="http://www.sfi.com.tw">http://www.sfi.com.tw</a> E-mail : <a href="mailto:sfi@sfi.com.tw">sfi@sfi.com.tw</a> TEL:886-3-3506998 FAX :886-3-3507689 - 6 -					

## 6. Packaging Specification

6.1 Carrier tape and transparent cover tape should be heat-sealed to carry the products, and the reel should be used to reel the carrier tape.

6.2 The adhesion of the heat-sealed cover tape shall be 40 +20/-15 grams.

6.3 Both the head and the end portion of the taping shall be empty for reel package and SMT auto-pickup machine. And a normal paper tape shall be connected in the head of taping for the operator to handle.

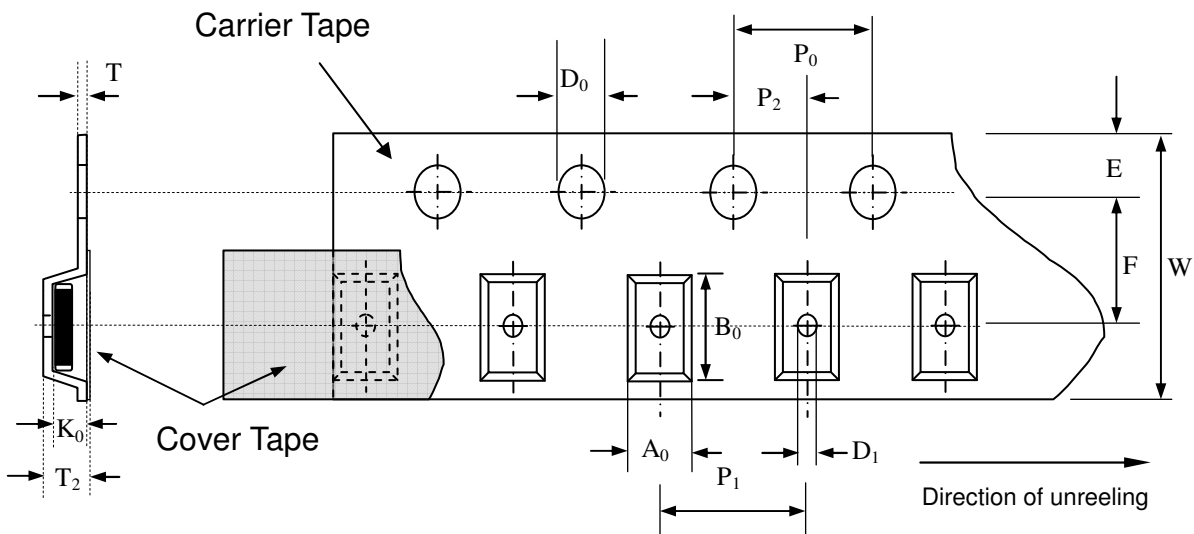

Symbol	$A_0$ $\pm 0.10$	$B_0$ $\pm 0.10$	$K_0$ $\pm 0.10$	$T$ $\pm 0.05$	$T_2$ $\pm 0.05$	$D_0$ $+0.10$ $-0.00$	$D_1$ $\pm 0.05$	$P_1$ $\pm 0.10$	$P_2$ $\pm 0.05$	$P_0$ $\pm 0.05$	$W$ $\pm 0.20$	$E$ $\pm 0.10$	$F$ $\pm 0.05$
1206	1.99	3.55	2.10	0.22	2.32	1.50	1.00	4.00	2.00	4.00	8.00	1.75	3.50

Part No. : **SFI1206SC750-501A** Document No. **AS-RD1206MA183-LF** REV. **C**

<http://www.sfi.com.tw> E-mail : [sfi@sfi.com.tw](mailto:sfi@sfi.com.tw) TEL:886-3-3506998 FAX :886-3-3507689 - 7 -

### 7.Reel Dimension

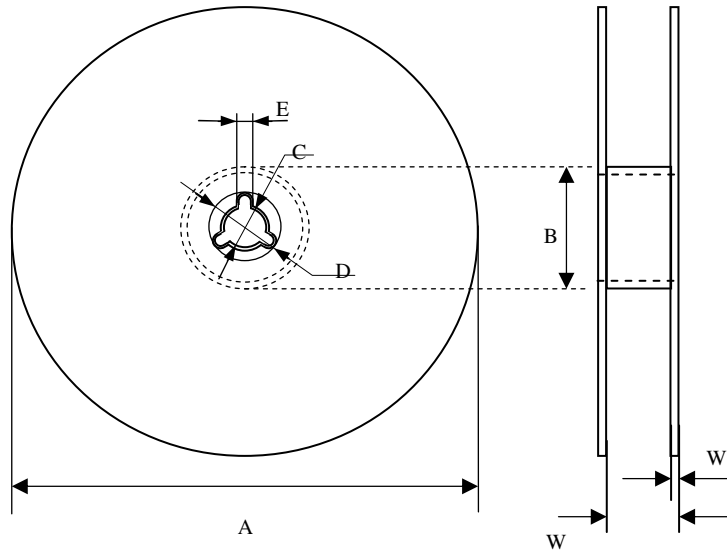

Symbol	A	B	C	D	E	W	W <sub>1</sub>
1206	178.0±1.0	60.0±0.5	13.0±0.2	21.0±0.2	2.0±0.5	9.0±0.50	1.5±0.15

### 8.Standard Packaging

Size	1206
Pcs	2000

Part No. :	<b>SFI1206SC750-501A</b>	Document No.	<b>AS-RD1206MA183-LF</b>	REV.	<b>C</b>
<a href="http://www.sfi.com.tw">http://www.sfi.com.tw</a> E-mail : <a href="mailto:sfi@sfi.com.tw">sfi@sfi.com.tw</a> TEL:886-3-3506998 FAX :886-3-3507689 - 8 -					



单击下面可查看定价，库存，交付和生命周期等信息

[>>SFI\(台湾立昌\)](#)