

## 1. PART NUMBER CODE

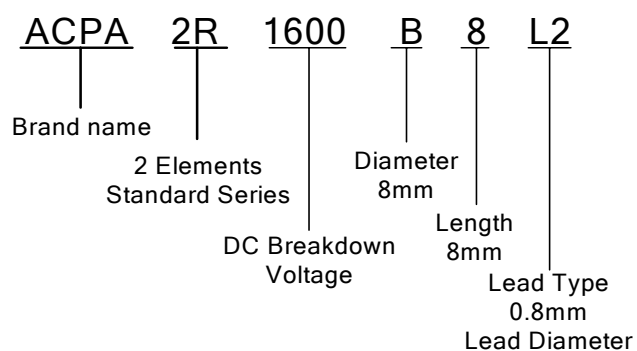

## 2. MARKING

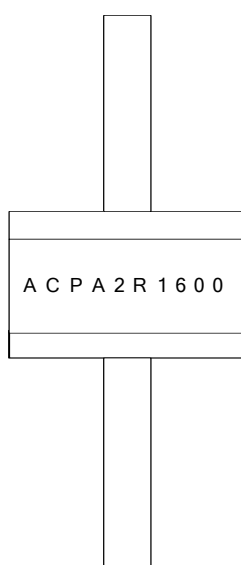

## 3. Outline Drawing

Unit: mm

Item	Dimensions
<b>D</b>	<b>8.0 +0.3,-0.5</b>
<b>T</b>	<b>8.0+0.6,-0.1</b>
<b>d</b>	<b>0.8±0.05</b>
<b>L</b>	<b>20min.</b>

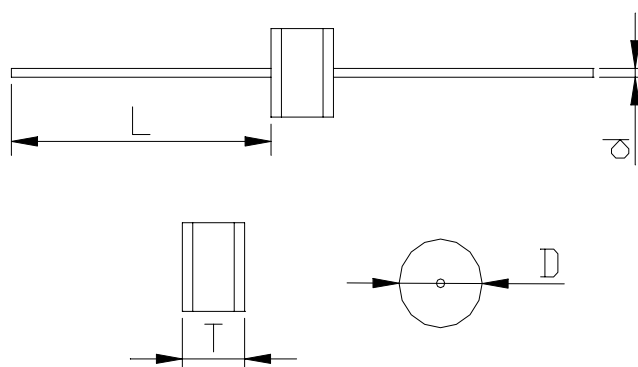

## 4. SPECIFICATION

### 4.1 ELECTRICAL SPECIFICATION

Model Name	DC Breakdown Voltage ( V )	Maximum Impulse Breakdown Voltage ( V )		Maximum Impulse Discharge Current ( 8/20 μs ) ( KA )		Normal Alternating Discharge Current ( A )		Impulse Life 10/1000μs ( 100A )	Minimum Insulation Resistance ( GΩ )	Maximum Capacitance ( pf )
		100V/μs	1000V/μs	1 time	10 times	50Hz, 1sec	Single 9cycles			
2R-1600	1600 ±20%	2300	2400	8	5	5	10	100	1	1.5

**Note1 : UL1449 C-UL 3rd Recognized,File E315423**

**Note2 : DC Breakdown Voltage      DC Measuring Voltage**

70-90V	50V
120-400V	100V
470-800V	250V
1000-2000V	500V
2500-6000V	1000V

### 4.2 Standard Bulk Packaging Specifications

Quantity: 100 pieces per plastic tray

500 pieces per inner box

10 inner boxes per carton

5000 pieces per full carton

## 5. ELECTRICAL RATING

Item	Test Condition / Description	Requirement	
DC Breakdown Voltage	The voltage measured at a rise time of 100v/s.	To meet the specified value	
Maximum Impulse Breakdown Voltage	The maximum breakdown voltage at rise times of 100v/us and 1000v/us.		
Maximum Impulse Discharge Current	The maximum current applying a waveform of 8/20us that can be applied across the terminals of the gas tube without causing the gas tube to change more than $\pm 25\%$ from its initial measured DC breakdown voltage. Dwell time between pulses is 3 minutes.		
Alternating Discharge Current	Rated RMS value of AC current at 50Hz, 1 sec. 10 times. Intervals: 3min. DC breakdown voltage may not change more than $\pm 25\%$ from its initial measured DC breakdown voltage. IR > $10^8$ ohms (-20%, +30% for 70 – 90V).		
Impulse Life	The minimum number of impulses of a specified waveform and peak current which a gas tube will conduct without causing the gas tube to change more than $\pm 25\%$ from its initial measured DC breakdown voltage. Dwell time between pulses is 1-2 minutes.		
DC Holdover Voltage	The maximum DC voltage across the two terminals of the gas tube under which it may be expected to return to the high impedance state after the gas tube breakdown.		
Insulation Resistance	The resistance of the gas tube shall be measured each terminal to each other terminal.		
	DC Breakdown Voltage		Measuring Voltage
	70-150V		50V
	151-400V		100V
	470-1000V	250V	
Capacitance	The capacitance of a gas tube shall be measured each terminal to each other terminal. Test frequency: 1MHz In measurements involving 3-electrode gas tubes, the terminal not being tested shall be connected to a ground plane.		
	1001-2000V	500V	
	2001-6000V	1000V	

单击下面可查看定价，库存，交付和生命周期等信息

[>>ACPA\(华格科技\)](#)