

THIS DRAWING IS UNPUBLISHED. RELEASED FOR PUBLICATION  
 © COPYRIGHT BY TYCO ELECTRONICS CORPORATION. ALL RIGHTS RESERVED.

LOC	DIST	REVISIONS					
		P	LTR	DESCRIPTION	DATE	DWN	APVD
AF	50		B1	ECR-06-023927(REDRAWN IN AUTOCAD)	05JUL06	HMR	GP

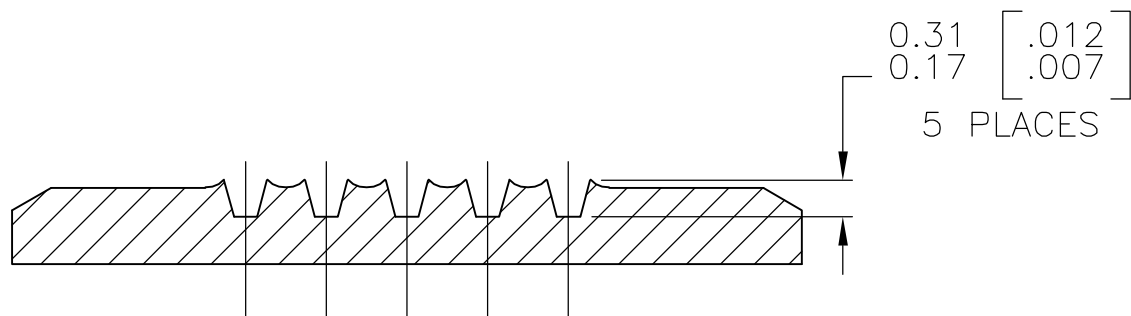
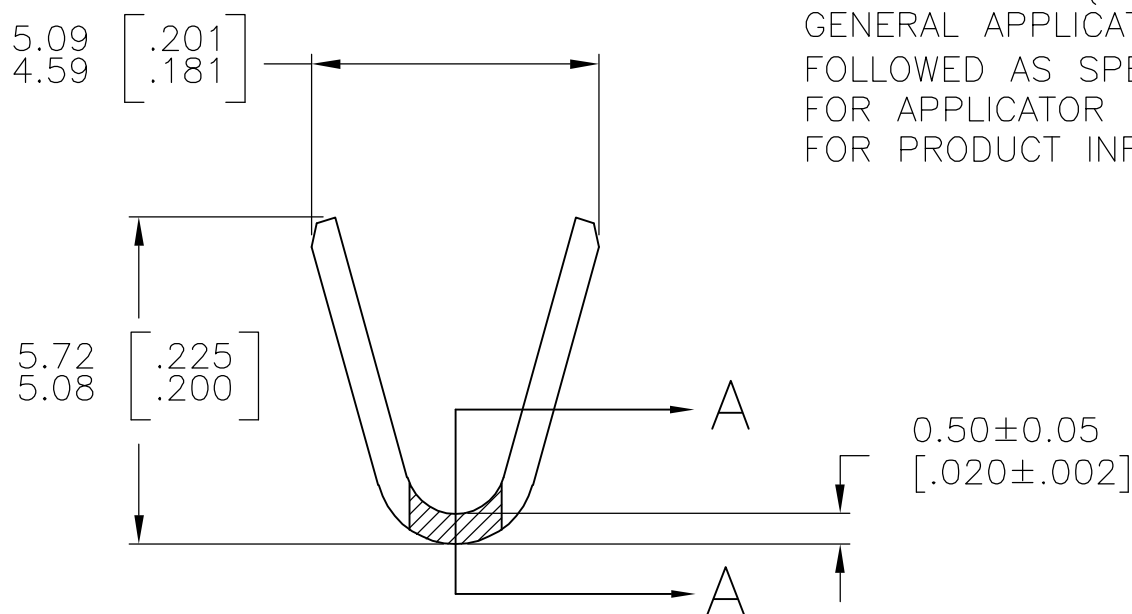
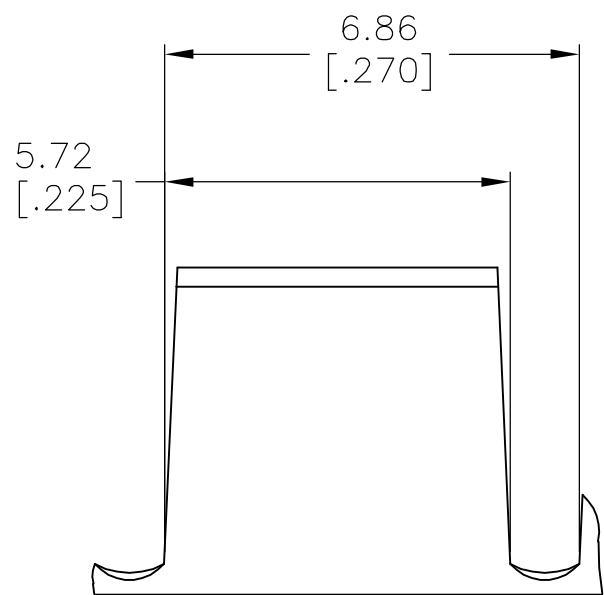
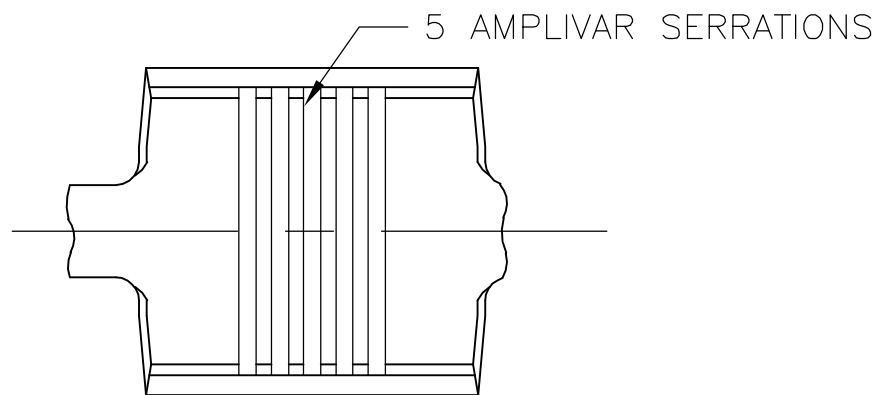

SECTION A-A  
SCALE 20:1

- CONTINUOUS STRIP ON REELS.
- DIMENSIONS IN BRACKETS ARE IN INCHES.
- FOR ADDITIONAL INFORMATION, SEE APPLICATION SPEC. 114-2009.
- WIRE RANGE: 3000-7000 CMA.
- CRIMP WIDTH: .140 F TYPE (AMPLIVAR THRU)  
 CRIMP HEIGHT (±.002)=(TOTAL CMA+14,600)/243,900  
 GENERAL APPLICATION GUIDELINES MUST BE FOLLOWED AS SPECIFIED IN CATALOG #82221  
 FOR APPLICATOR INFORMATION CALL:1-800-722-1111  
 FOR PRODUCT INFORMATION CALL:1-800-522-6752

41900  
PART NO

THIS DRAWING IS A CONTROLLED DOCUMENT.		DWN RAGHAVENDRA 05JUL06	Tyco Electronics Corporation Harrisburg, PA 17105-3608	
DIMENSIONS: mm [INCHES]	TOLERANCES UNLESS OTHERWISE SPECIFIED:	CHK G.D.PORTA	NAME	
	0 PLC ± -	APVD G.D.PORTA	PRODUCT SPEC	
	1 PLC ± -		APPLICATION SPEC	
	2 PLC ± -		SIZE CAGE CODE DRAWING NO RESTRICTED TO	
	3 PLC ± 0.38 [.015]		A3 00779 C-41900	
	4 PLC ± -		SCALE 8:1 SHEET 1 OF 1 REV B1	
	ANGLES ± 1' 0"			
MATERIAL BRASS	FINISH TIN PLATE	WEIGHT -	CUSTOMER DRAWING	

单击下面可查看定价，库存，交付和生命周期等信息

[>>TE Connectivity\(泰科\)](#)