

800mA Low Dropout Fast Response Positive Adjustable Regulator and Fixed
1.8V, 2.5V, and 3.3V

Features

- **Guaranteed Output Voltage Accuracy within 2%**
- **Fast Transient Response**
- **Guaranteed Dropout Voltage at Multiple Currents**
- **Load Regulation : 0.6% Typ.**
- **Line Regulation : 0.03% Typ.**
- **Low Dropout Voltage : 1.3V Typ. at $I_{OUT}=500mA$**
- **Current-Limit : 0.8A Min. at $T_J=125^{\circ}C$**
- **On-Chip Thermal Limiting : 150 °C Typ.**
- **Adjustable Output : 1.25~7.15V**
- **Standard 3-Pin SOT-89, SOT-223, TO-92, and TO- 252 Power Packages.**
- **Lead Free and Green Devices Available (RoHS Compliant)**

General Description

The APL1087 is a low dropout three-terminal adjustable regulators with 0.8A output current capability. In order to obtain lower dropout voltage and faster transient response, which is critical for low voltage applications, the APL1087 has been optimized.

The device is available in an adjustable version and fixed output voltages of 1.8V, 2.5V, and 3.3V, the output available voltage range is from 1.25 to 7.15V with an input supply below 9V. Dropout voltage is guaranteed at a maximum of 1.45V at 0.5A.

Current limit is trimmed to ensure specified output current and controlled short-circuit current. On-chip thermal limiting provides protection against any combination of overload that would create excessive junction temperatures.

The APL1087 is available in the industry standard 3-pin SOT-89, SOT-223, TO-92, and TO-252 power packages.

Simplified Application Circuits

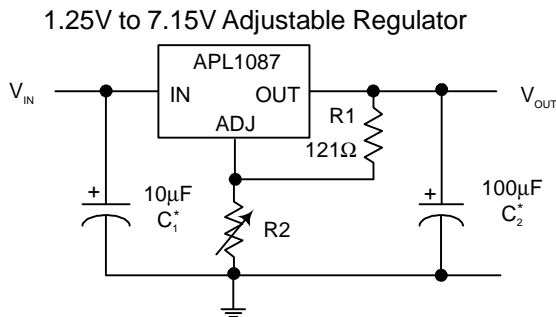

* Needed if device is far from filter capacitors

$$V_{OUT} = 1.250V \times \frac{R1 + R2}{R1}$$

5V Regulator with Shutdown

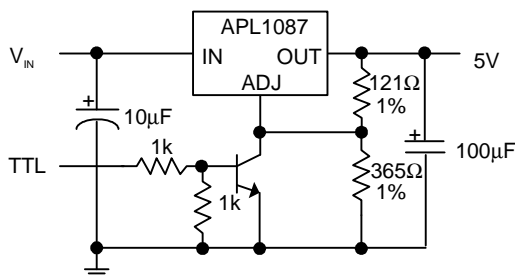

Applications

- **Voltage Regulator for CD-ROM Drivers**
- **Voltage Regulator for LAN Cards**
- **Voltage Regulator for Mother Boards**
- **Wireless Communication Systems**
- **Portable Instrument**
- **Portable Consumer Equipment**
- **Low Voltage Systems**



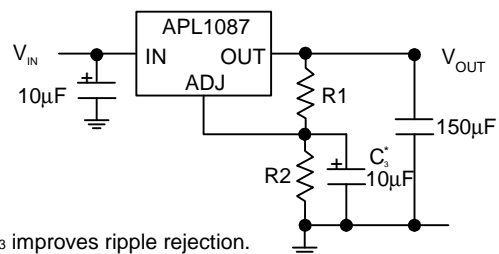





Improving Ripple Rejection

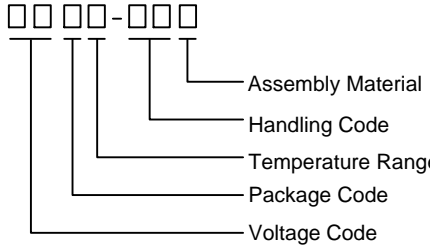

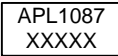
* C_3 improves ripple rejection.
Xc should be approximately equal to $R1$ at ripple frequency

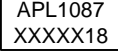
ANPEC reserves the right to make changes to improve reliability or manufacturability without notice, and advise customers to obtain the latest version of relevant information to verify before placing orders.

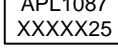
Ordering and Marking Information

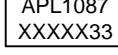
<p>APL1087 □□□□-□□□□</p>  <ul style="list-style-type: none"> — Assembly Material — Handling Code — Temperature Range — Package Code — Voltage Code 	<p>Package Code D : SOT-89 E : TO-92 U : TO-252 V : SOT-223</p> <p>Operating Ambient Temperature Range C : 0 to 70 °C</p> <p>Handling Code TB : Tape & Box TR : Tape & Reel</p> <p>Voltage Code 18 : 1.8V 25 : 2.5V 33 : 3.3V</p> <p>Blank : Adjustable Version</p> <p>Assembly Material G : Halogen and Lead Free Device</p>
<p>APL1087 U:  XXXXX - Date Code</p>	<p>APL1087 D/V/E :  XXXXX - Date Code</p>
<p>APL1087-18U:  XXXXX - Date Code</p>	<p>APL1087-18D/V/E :  XXXXX - Date Code</p>
<p>APL1087-25U:  XXXXX - Date Code</p>	<p>APL1087-25D/V/E :  XXXXX - Date Code</p>
<p>APL1087-33U:  XXXXX - Date Code</p>	<p>APL1087-33D/V/E :  XXXXX - Date Code</p>

Note: ANPEC lead-free products contain molding compounds/die attach materials and 100% matte tin plate termination finish; which are fully compliant with RoHS. ANPEC lead-free products meet or exceed the lead-free requirements of IPC/JEDEC J-STD-020C for MSL classification at lead-free peak reflow temperature. ANPEC defines "Green" to mean lead-free (RoHS compliant) and halogen free (Br or Cl does not exceed 900ppm by weight in homogeneous material and total of Br and Cl does not exceed 1500ppm by weight).

Pin Configurations

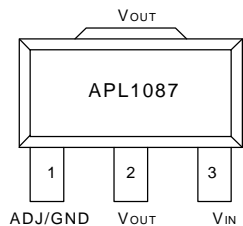

SOT-89 (Front View)

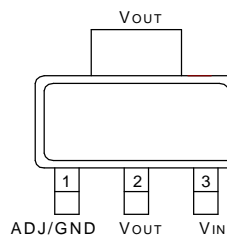

SOT-223 (Front View)

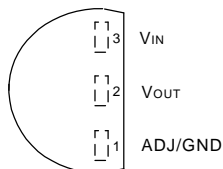

TO-92 (Top View)

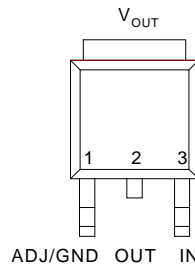

TO-252 (Top View)

Absolute Maximum Ratings

Symbol	Parameter	Rating	Unit
V_I	Input Voltage	9	V
T_{STG}	Storage Temperature Range	-65 ~ +150	°C
T_L	Maximum Lead Soldering Temperature, 10 Seconds	260	°C

Thermal Characteristics

Symbol	Parameter	Typical Value	Unit
T_J	Operating Junction Temperature Range	Control Section	0 to 125
		Power Transistor	0 to 150
θ_{JA}	Thermal Resistance from Junction to Ambient in Free Air	SOT-89	180
		SOT-223	75
		TO-92	180
		TO-252	62.5
θ_{JC}	Thermal Resistance from Junction to Ambient in Free Air	SOT-89	38
		SOT-223	15
		TO-92	80
		TO-252	6

Electrical Characteristics

Symbol	Parameter	Test Conditions	APL1087			Unit
			Min.	Typ.	Max.	
V_{REF}	Reference Voltage	$10mA \leq I_{OUT} \leq 0.5A, 3.1V \leq V_{IN} \leq 9V, T_J = 0 \sim 125^\circ C$	1.225	1.250	1.275	V
V_{OUT}	Output Voltage	APL1087-18 $T_J = 0 \sim 125^\circ C, 0 \leq I_{OUT} \leq 0.5A, 3.25V \leq V_{IN} \leq 9V,$	1.764	1.800	1.836	V
		APL1087-25 $T_J = 0 \sim 125^\circ C, 0 \leq I_{OUT} \leq 0.5A, 3.95V \leq V_{IN} \leq 9V,$	2.450	2.500	2.550	
		APL1087-33 $T_J = 0 \sim 125^\circ C, 0 \leq I_{OUT} \leq 0.5A, 4.75V \leq V_{IN} \leq 9V,$	3.235	3.300	3.365	
REG_{LINE}	Line Regulation	$T_J = 0 \sim 125^\circ C$				
		APL1087 $I_{OUT} = 10mA, 3.1V \leq V_{IN} \leq 9V$ (Note1)	-	0.03	0.2	
		APL1087-18 $I_{OUT} = 0mA, 3.25V \leq V_{IN} \leq 9V$ (Note1)	-	1	6	
		APL1087-25 $I_{OUT} = 0mA, 3.95V \leq V_{IN} \leq 9V$ (Note1)	-	1	6	
APL1087-33 $I_{OUT} = 0mA, 4.75V \leq V_{IN} \leq 9V$ (Note1)	-	1	6			
REG_{LOAD}	Load Regulation	$T_J = 0 \sim 125^\circ C$				
		APL1087 $(V_{IN} - V_{OUT}) = 3V, 0 \leq I_{OUT} \leq 0.5A$ (Note1)	-	0.4	0.6	
		APL1087-18 $V_{IN} = 3.25V, 0 \leq I_{OUT} \leq 0.5A$ (Note1)	-	0.4	0.6	
		APL1087-25 $V_{IN} = 3.95V, 0 \leq I_{OUT} \leq 0.5A$ (Note1)	-	0.4	0.6	
APL1087-33 $V_{IN} = 4.75V, 0 \leq I_{OUT} \leq 0.5A$ (Note1)	-	0.4	0.6			
V_D	Dropout Voltage	$I_{OUT} = 0.5A, T_J = 0 \sim 125^\circ C$ (Note2)	-	1.3	1.45	V
I_{LIMIT}	Current Limit	$(V_{IN} - V_{OUT}) = 5V, T_J = 25^\circ C$	800	-	-	mA
I_{ADJ}	Adjust Pin Current	$(V_{IN} - V_{OUT}) = 3V, I_{OUT} = 10mA, T_J = 0 \sim 125^\circ C$	-	60	120	μA
ΔI_{ADJ}	Adjust Pin Current Change	$T_J = 0 \sim 125^\circ C, 10mA \leq I_{OUT} \leq 0.5A, 1.45V \leq V_{IN} - V_{OUT} \leq 7.55V$	-	0.2	5	μA
I_O	Minimum Load Current	$T_J = 0 \sim 125^\circ C, V_{IN} = 9V$ (Note3)	-	1.7	-	mA

Electrical Characteristics (Cont.)

Symbol	Parameter	Test Conditions	APL1087			Unit
			Min.	Typ.	Max.	
PSRR	Ripple Rejection	$F_{\text{RIPPLE}}=120\text{Hz}$, $V_{\text{RIPPLE}}=1V_{\text{P-P}}$, ($V_{\text{IN}}-V_{\text{OUT}}=3\text{V}$, $T_{\text{J}}=0\sim 125^{\circ}\text{C}$)	60	75	-	dB
T_{R}	Thermal Regulation	$T_{\text{J}}=25^{\circ}\text{C}$, 30ms Pulse	-	0.01	0.02	%/ W
T_{S}	Temperature Stability		-	0.5	-	%
L_{S}	Long -Term Stability	$T_{\text{J}}=125^{\circ}\text{C}$, 1000Hrs.	-	0.3	-	%
V_{N}	RMS Output Noise	$T_{\text{J}}=25^{\circ}\text{C}$, $10\text{Hz}\leq F\leq 10\text{kHz}$, (% of V_{OUT})	-	0.003	-	%
OT	Over Temperature Point		-	150	-	$^{\circ}\text{C}$
	Quiescent Current	$T_{\text{J}}=0\sim 125^{\circ}\text{C}$,				
	APL1087-18	$V_{\text{IN}}\leq 9\text{V}$	-	5.5	10	mA
	APL1087-25	$V_{\text{IN}}\leq 9\text{V}$		5.5	10	
	APL1087-33	$V_{\text{IN}}\leq 9\text{V}$		5.5	10	

Note : 1 : See thermal regulation specifications for changes in output voltage due to heating effects. Load line regulations are measured at a constant junction temperature by low duty cycle pulse testing.

2 : Dropout voltage is specified over the full output current range of the device. Dropout voltage is defined as the minimum input/output differential measured at the specified output current. Test points and limits are also shown on the Dropout Voltage curve.

3 : Minimum load current is defined as the minimum output current required to maintain regulation.

Typical Operating Characteristics

Load Transient Response

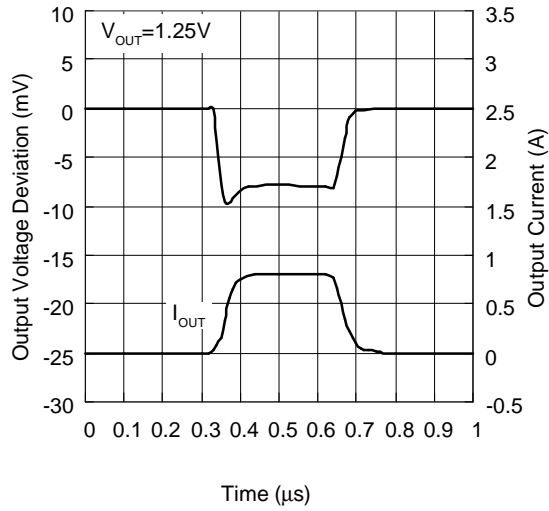

Line Transient Response

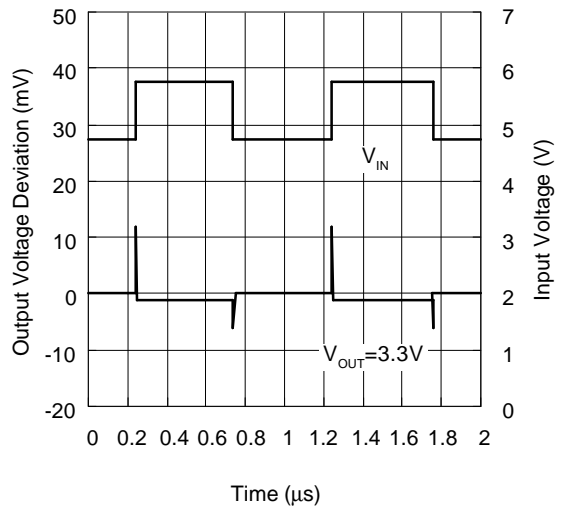

Adjust Pin Current vs. Temperature

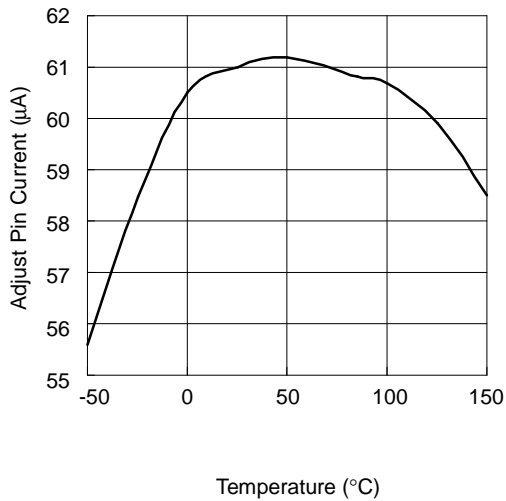

Current Limit vs. Temperature

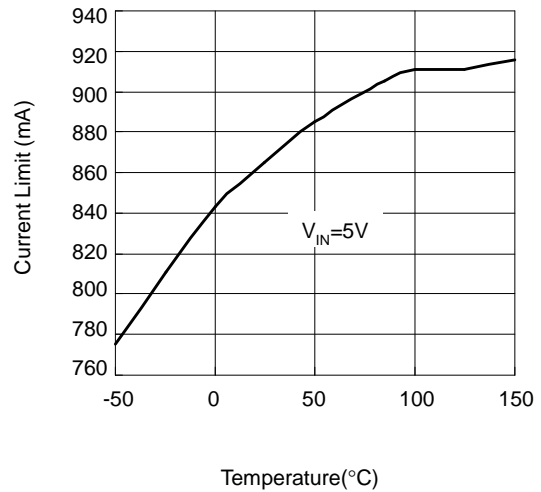

Typical Operating Characteristics (Cont.)

Dropout Voltage vs. Temperature

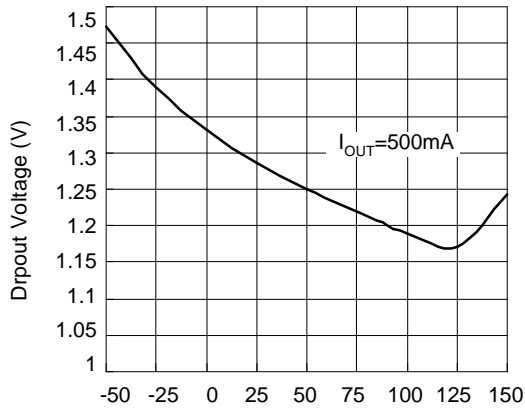

Temperature (°C)

Reference Voltage vs. Temperature

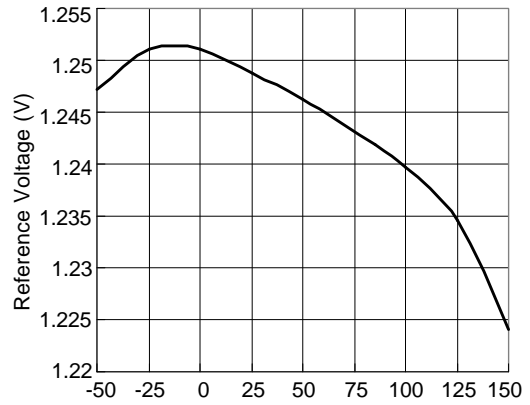

Temperature (°C)

Output Voltage vs. Temperature

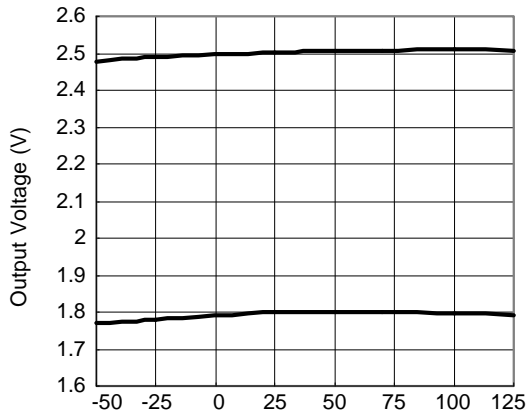

Temperature (°C)

Output Voltage vs. Temperature

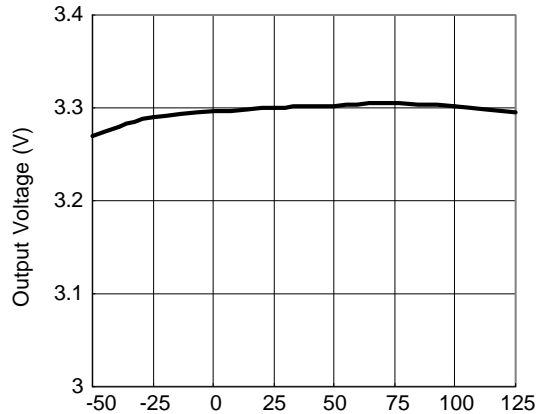

Temperature (°C)

Typical Operating Characteristics (Cont.)

Output Voltage vs. Input Voltage

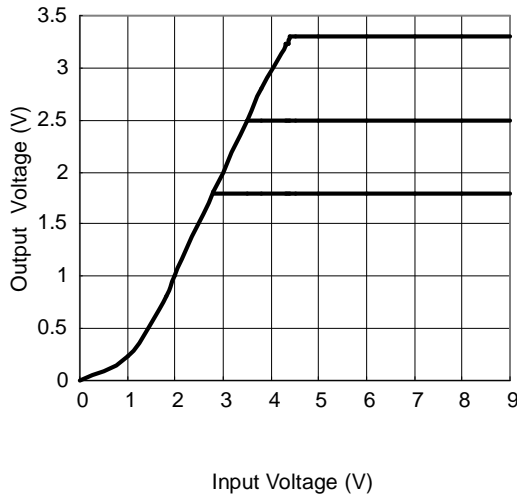

Current Limit vs. Input Voltage

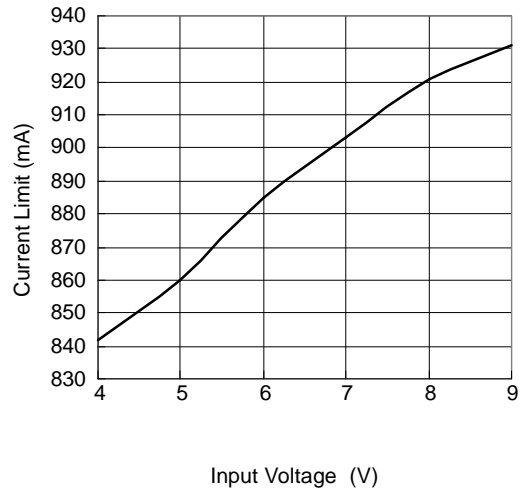

Load Regulation vs. Output Current

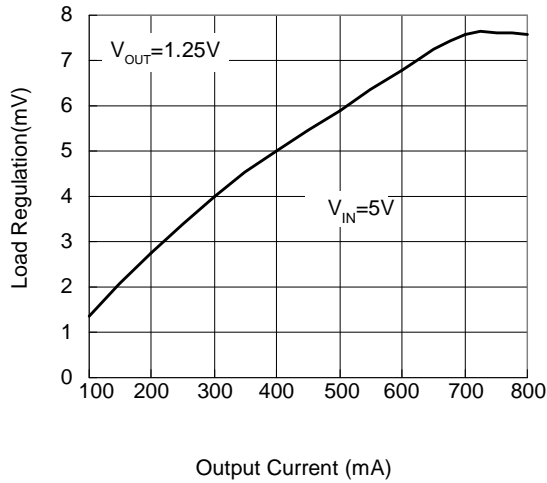

Dropout Voltage vs. Output Current

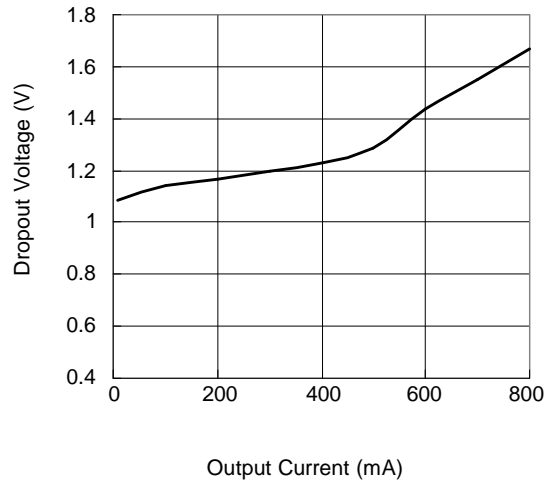

Package Information

SOT-89

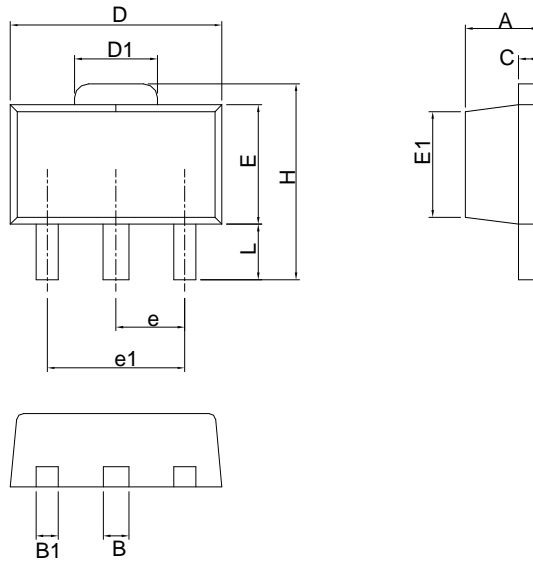

SYMBOL	SOT-89			
	MILLIMETERS		INCHES	
	MIN.	MAX.	MIN.	MAX.
A	1.40	1.60	0.055	0.063
B	0.44	0.56	0.017	0.022
B1	0.36	0.48	0.014	0.019
C	0.35	0.44	0.014	0.017
D	4.40	4.60	0.173	0.181
D1	1.62	1.83	0.064	0.072
E	2.29	2.60	0.090	0.102
E1	2.13	2.29	0.084	0.090
e	1.50 BSC		0.059 BSC	
e1	3.00 BSC		0.118 BSC	
H	3.94	4.25	0.155	0.167
L	0.89	1.20	0.035	0.047

Note : Follow from JEDEC TO-243 AA.

Package Information

SOT-223

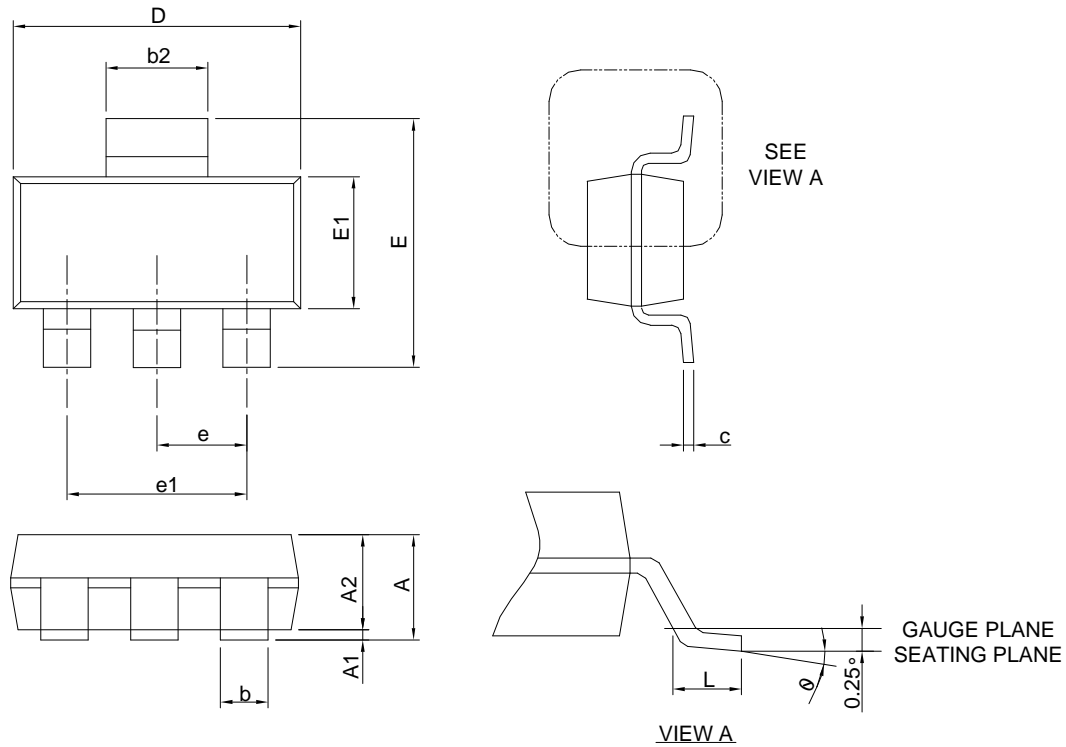

SYMBOL	SOT-223			
	MILLIMETERS		INCHES	
	MIN.	MAX.	MIN.	MAX.
A		1.80		0.071
A1	0.02	0.10	0.001	0.004
A2	1.50	1.70	0.059	0.067
b	0.66	0.84	0.026	0.033
b2	2.90	3.10	0.114	0.122
c	0.23	0.33	0.009	0.013
D	6.30	6.70	0.248	0.264
E	6.70	7.30	0.264	0.287
E1	3.30	3.70	0.130	0.146
e	2.30 BSC		0.091 BSC	
e1	4.60 BSC		0.181 BSC	
L	0.75		0.030	
θ	0°	10°	0°	10°

Note : 1. Follow from JEDEC TO-261 AA.
 2. Dimension D and E1 are determined at the outermost extremes of the plastic exclusive of mold flash, tie bar burrs, gate burrs, and interlead flash, but including any mismatch between the top and bottom of the plastic body.

Package Information

TO-92

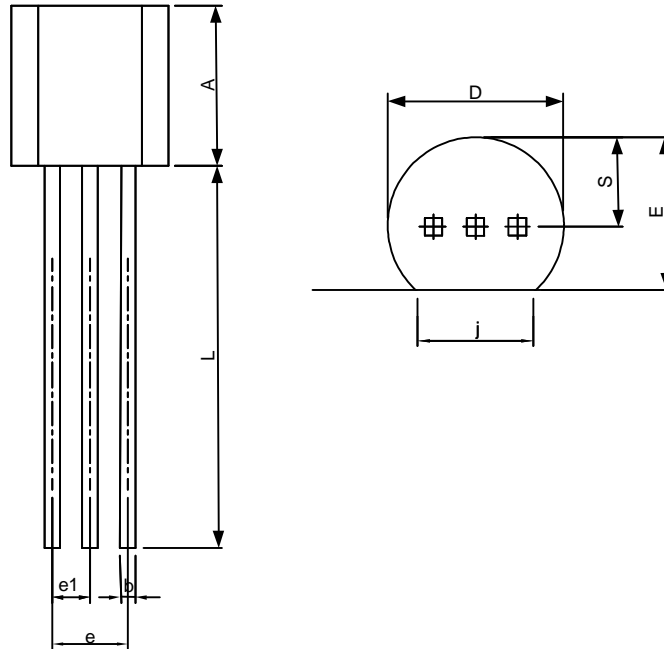

SYMBOL	TO-92			
	MILLIMETERS		INCHES	
	MIN.	MAX.	MIN.	MAX.
A	4.32	5.33	0.170	0.210
b	0.41	0.53	0.016	0.021
D	4.45	5.20	0.175	0.205
E	3.18	4.19	0.125	0.165
e	2.42	2.66	0.095	0.105
e1	1.15	1.39	0.045	0.055
j	3.43	4.00	0.135	0.157
L	12.70	15.00	0.500	0.591
S	2.03	2.66	0.080	0.105

Note : Follow from JEDEC TO-92.

Package Information

TO-252

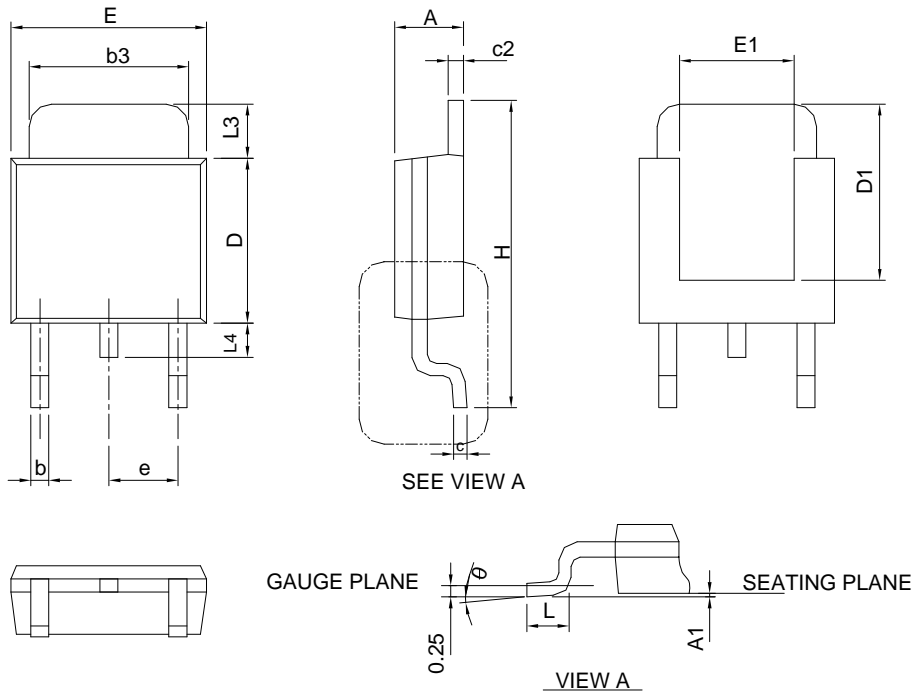

SYMBOL	TO-252			
	MILLIMETERS		INCHES	
	MIN.	MAX.	MIN.	MAX.
A	2.18	2.39	0.086	0.094
A1		0.13		0.005
b	0.50	0.89	0.020	0.035
b3	4.95	5.46	0.195	0.215
c	0.46	0.61	0.018	0.024
c2	0.46	0.89	0.018	0.035
D	5.33	6.22	0.210	0.245
D1	4.57	6.00	0.180	0.236
E	6.35	6.73	0.250	0.265
E1	3.81	6.00	0.150	0.236
e	2.29 BSC		0.090 BSC	
H	9.40	10.41	0.370	0.410
L	0.90	1.78	0.035	0.070
L3	0.89	2.03	0.035	0.080
L4		1.02		0.040
θ	0°	8°	0°	8°

Note : Follow from JEDEC TO-252 .

Carrier Tape & Reel Dimensions

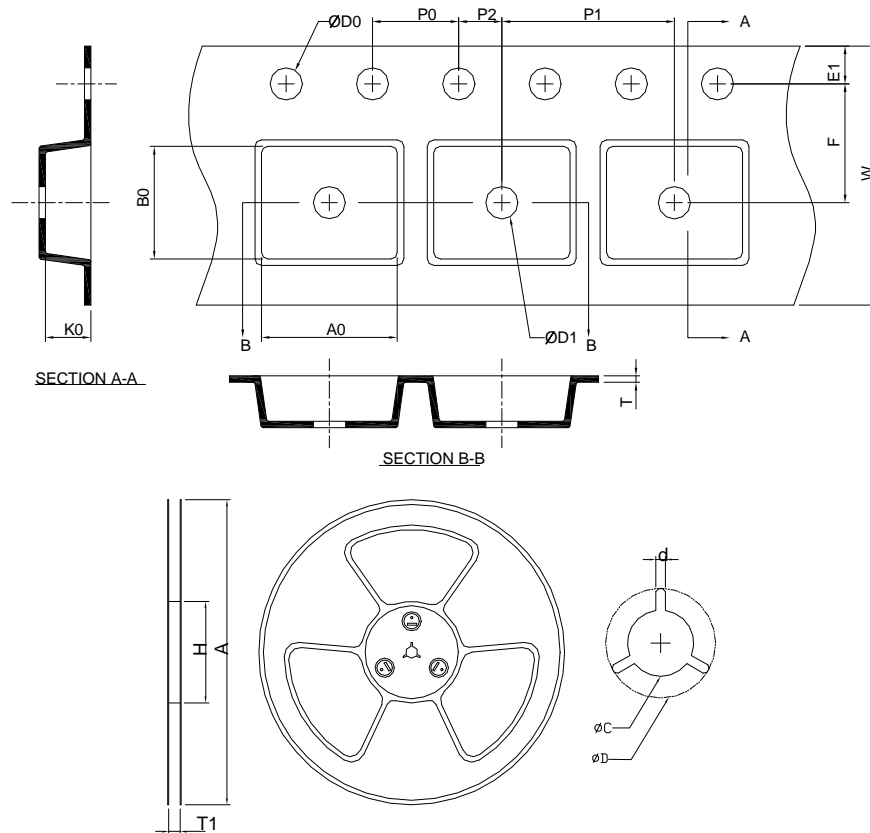

Application	A	H	T1	C	d	D	W	E1	F
SOT-89	178.0 ±0.00	50 MIN.	12.4+2.00 -0.00	13.0+0.50 -0.20	1.5 MIN.	20.2 MIN.	12.0 ±0.30	1.75 ±0.10	5.50 ±0.05
	P0	P1	P2	D0	D1	T	A0	B0	K0
	4.0 ±0.10	8.0 ±0.10	2.0 ±0.05	1.5+0.10 -0.00	1.5 MIN.	0.6+0.00 -0.40	4.80 ±0.20	4.50 ±0.20	1.80 ±0.20
Application	A	H	T1	C	d	D	W	E1	F
SOT-223	320.0 ±0.00	50 MIN.	12.4+2.00 -0.00	13.0+0.50 -0.20	1.5 MIN.	20.2 MIN.	12.00 ±0.30	1.75 ±0.10	5.50 ±0.05
	P0	P1	P2	D0	D1	T	A0	B0	K0
	4.00 ±0.10	8.00 ±0.10	2.00 ±0.50	1.5+0.10 -0.00	1.5 MIN.	0.6+0.00 -0.40	6.90 ±0.20	7.50 ±0.20	2.10 ±0.20
Application	A	H	T1	C	d	D	W	E1	F
TO-252	330.0 ±0.00	50 MIN.	16.4+2.00 -0.00	13.0+0.50 -0.20	1.5 MIN.	20.2 MIN.	16.0 ±0.30	1.75 ±0.10	7.50 ±0.05
	P0	P1	P2	D0	D1	T	A0	B0	K0
	4.0 ±0.10	8.0 ±0.10	2.0 ±0.05	1.5+0.10 -0.00	1.5 MIN.	0.6+0.00 -0.40	6.80 ±0.20	10.40 ±0.20	2.50 ±0.20

(mm)

Carrier Tape & Box Dimensions

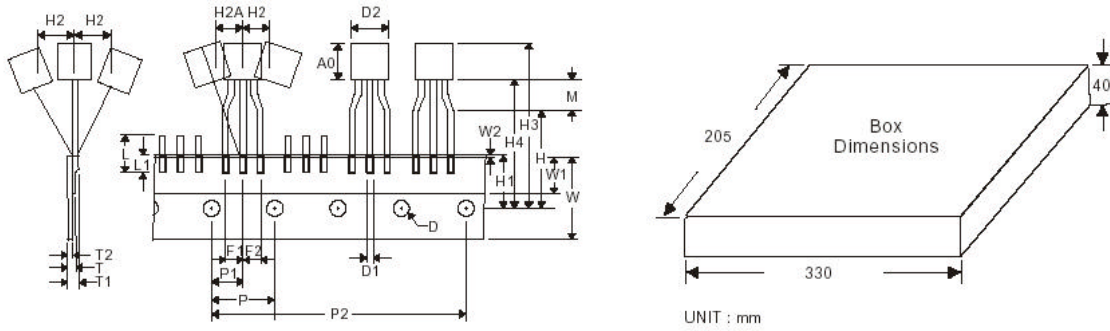

Devices Per Unit

Package Type	Unit	Quantity
SOT-89	Tape & Reel	1000
TO-252	Tape & Reel	2500
SOT-223	Tape & Reel	2500
TO-92	Tape & Box	2000

Taping Direction Information

SOT-89

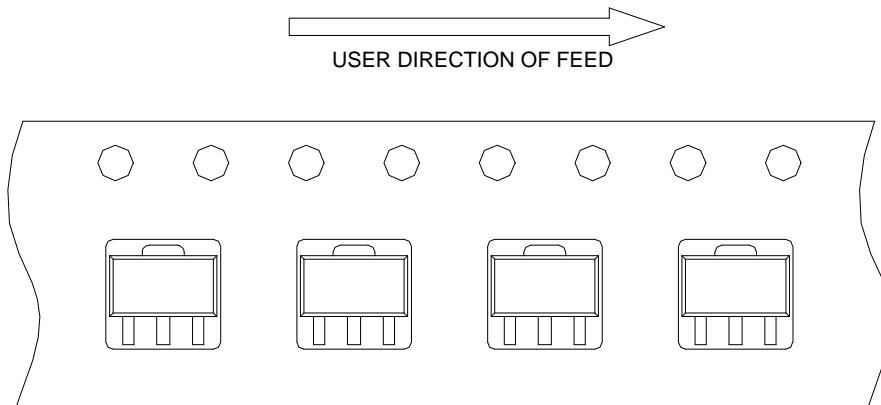

Taping Direction Information (Cont.)

SOT-223

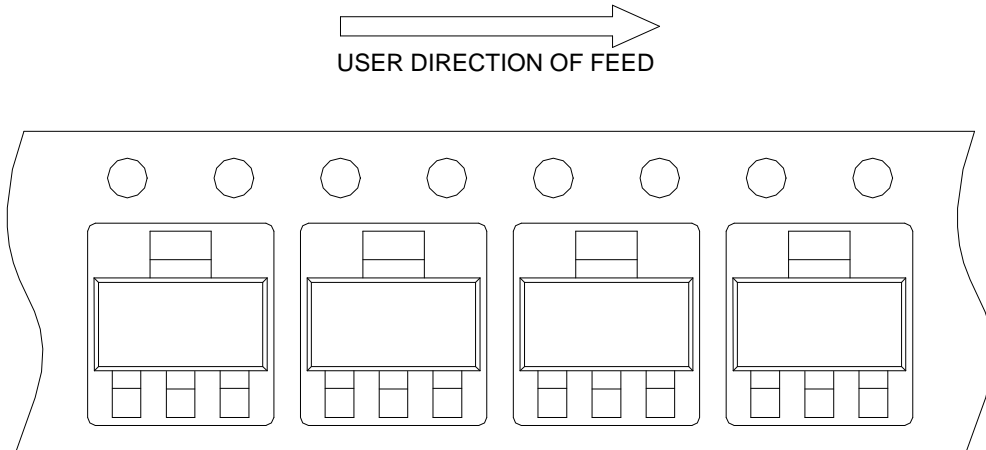

TO-252

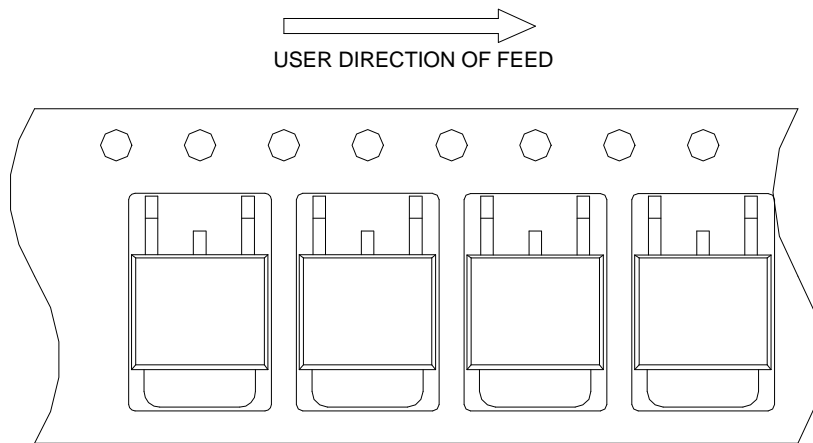

Reflow Condition (IR/Convection or VPR Reflow)

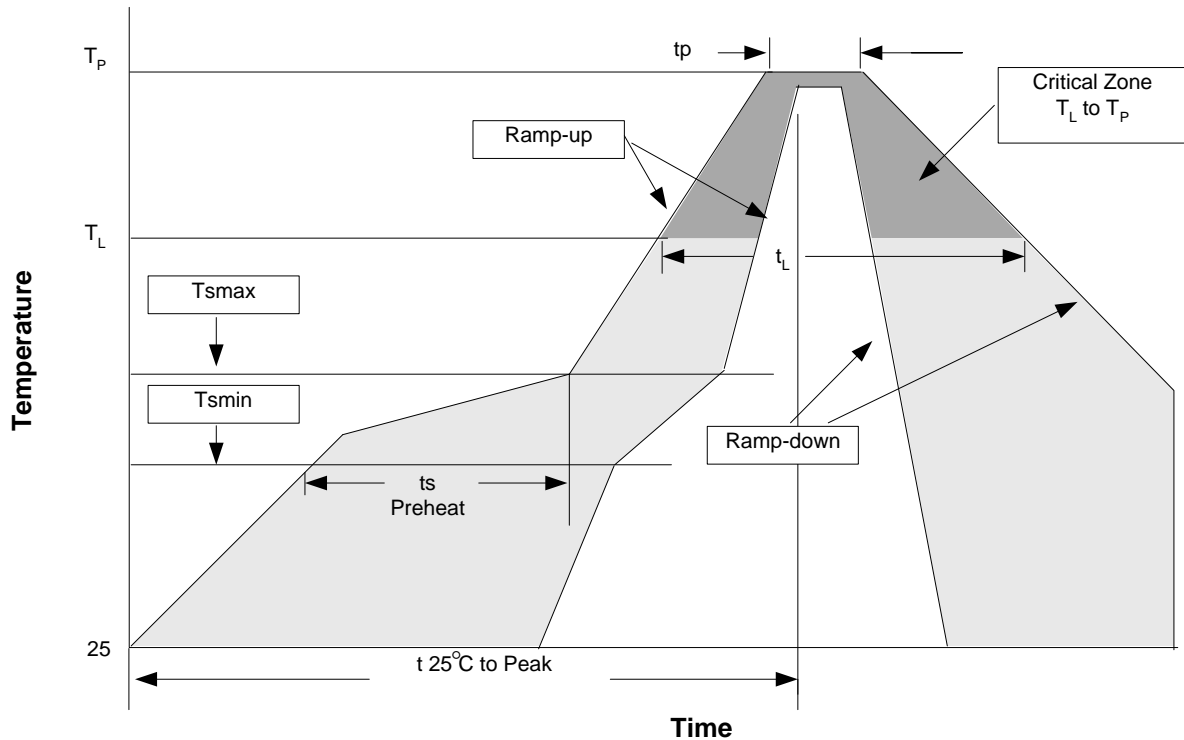

Reliability Test Program

Test item	Method	Description
SOLDERABILITY	MIL-STD-883D-2003	245°C, 5 sec
HOLT	MIL-STD-883D-1005.7	1000 Hrs Bias @125°C
PCT	JESD-22-B,A102	168 Hrs, 100%RH, 121°C
TST	MIL-STD-883D-1011.9	-65°C~150°C, 200 Cycles
ESD	MIL-STD-883D-3015.7	VHBM > 2KV, VMM > 200V
Latch-Up	JESD 78	10ms, 1 _{tr} > 100mA

Classification Reflow Profiles

Profile Feature	Sn-Pb Eutectic Assembly	Pb-Free Assembly
Average ramp-up rate (T _L to T _P)	3°C/second max.	3°C/second max.
Preheat		
- Temperature Min (T _{min})	100°C	150°C
- Temperature Max (T _{max})	150°C	200°C
- Time (min to max) (t _s)	60-120 seconds	60-180 seconds
Time maintained above:		
- Temperature (T _L)	183°C	217°C
- Time (t _L)	60-150 seconds	60-150 seconds
Peak/Classification Temperature (T _p)	See table 1	See table 2
Time within 5°C of actual Peak Temperature (t _p)	10-30 seconds	20-40 seconds
Ramp-down Rate	6°C/second max.	6°C/second max.
Time 25°C to Peak Temperature	6 minutes max.	8 minutes max.

Notes: All temperatures refer to topside of the package. Measured on the body surface.

Classification Reflow Profiles (Cont.)

Table 1. SnPb Eutectic Process – Package Peak Reflow Temperatures

Package Thickness	Volume mm ³ <350	Volume mm ³ ≥350
<2.5 mm	240 +0/-5°C	225 +0/-5°C
≥2.5 mm	225 +0/-5°C	225 +0/-5°C

Table 2. Pb-free Process – Package Classification Reflow Temperatures

Package Thickness	Volume mm ³ <350	Volume mm ³ 350-2000	Volume mm ³ >2000
<1.6 mm	260 +0°C*	260 +0°C*	260 +0°C*
1.6 mm – 2.5 mm	260 +0°C*	250 +0°C*	245 +0°C*
≥2.5 mm	250 +0°C*	245 +0°C*	245 +0°C*

*Tolerance: The device manufacturer/supplier **shall** assure process compatibility up to and including the stated classification temperature (this means Peak reflow temperature +0°C. For example 260°C+0°C) at the rated MSL level.

Customer Service

Anpec Electronics Corp.

Head Office :

No.6, Dusing 1st Road, SBIP,

Hsin-Chu, Taiwan, R.O.C.

Tel : 886-3-5642000

Fax : 886-3-5642050

Taipei Branch :

2F, No. 11, Lane 218, Sec 2 Jhongsing Rd.,

Sindian City, Taipei County 23146, Taiwan, R. O. C.

Tel : 886-2-2910-3838

Fax : 886-2-2917-3838

单击下面可查看定价，库存，交付和生命周期等信息

[>>ANPEC\(台湾茂达\)](#)