

Low-Noise, Positive-Regulated Charge Pump

Features:

- Inductorless, Buck/Boost, DC/DC Converter
- Low Power: 80 μ A (Typical)
- High Output Voltage Accuracy:
 - $\pm 2.5\%$ (V_{OUT} Fixed)
- 120 mA Output Current
- Wide Operating Temperature Range:
 - Industrial Temperature (I): -40°C to $+85^{\circ}\text{C}$
 - Extended Temperature (E): -40°C to $+125^{\circ}\text{C}$
- Thermal Shutdown and Short-Circuit Protection
- Uses Small Ceramic Capacitors
- Switching Frequency:
 - MCP1252: 650 kHz
 - MCP1253: 1 MHz
- Low-Power Shutdown Mode: 0.1 μ A (Typical)
- Shutdown Input Compatible with 1.8V Logic
- V_{IN} Range: 2.0V to 5.5V
- Selectable Output Voltage (3.3V or 5.0V) or Adjustable Output Voltage
- Space-Saving, 8-Lead MSOP
- Soft-Start Circuitry to Minimize In-Rush Current
- AEC-Q100 Qualified

Applications:

- White LED Backlighting
- Color Display Bias
- Local 3V-to-5V Conversions
- Flash Memory Supply Voltage
- SIM Interface Supply for GSM Phones
- Smart Card Readers
- PCMCIA Local 5V Supplies

Description:

The MCP1252/3 are inductorless, positive-regulated charge pump DC/DC converters. The devices generate a regulated fixed (3.3V or 5.0V) or adjustable output voltage. They are specifically designed for applications requiring low noise and high efficiency and are able to deliver up to 120 mA output current. The devices allow the input voltage to be lower or higher than the output voltage, by automatically switching between buck/boost operation.

The MCP1252 has a switching frequency of 650 kHz, avoiding interference with sensitive IF bands. The MCP1253 has a switching frequency of 1 MHz and allows the use of smaller capacitors than the MCP1252, thus saving board space and cost.

Both devices feature a power-good output that can be used to detect out-of-regulation conditions. Extremely low supply current and low external parts count (three capacitors) make these devices ideal for small, battery-powered applications. A shutdown mode is also provided for further power reduction. The MCP1252 and MCP1253 feature thermal and short-circuit protection and are offered in space-saving, 8-lead, MSOP packages.

Package Types

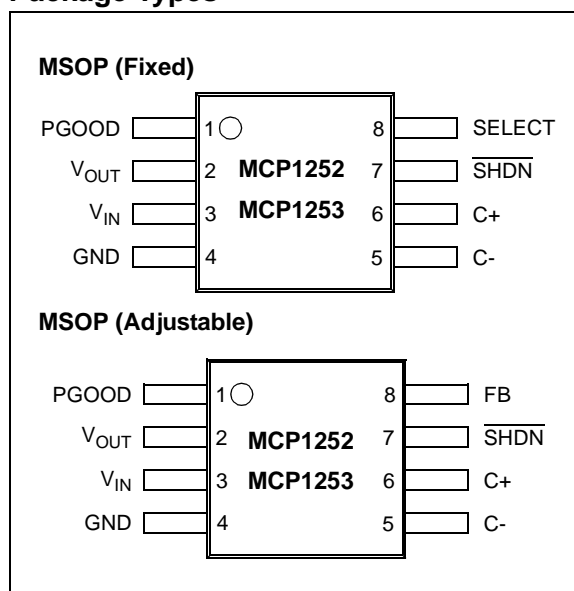

MCP1252/3

Functional Block Diagram

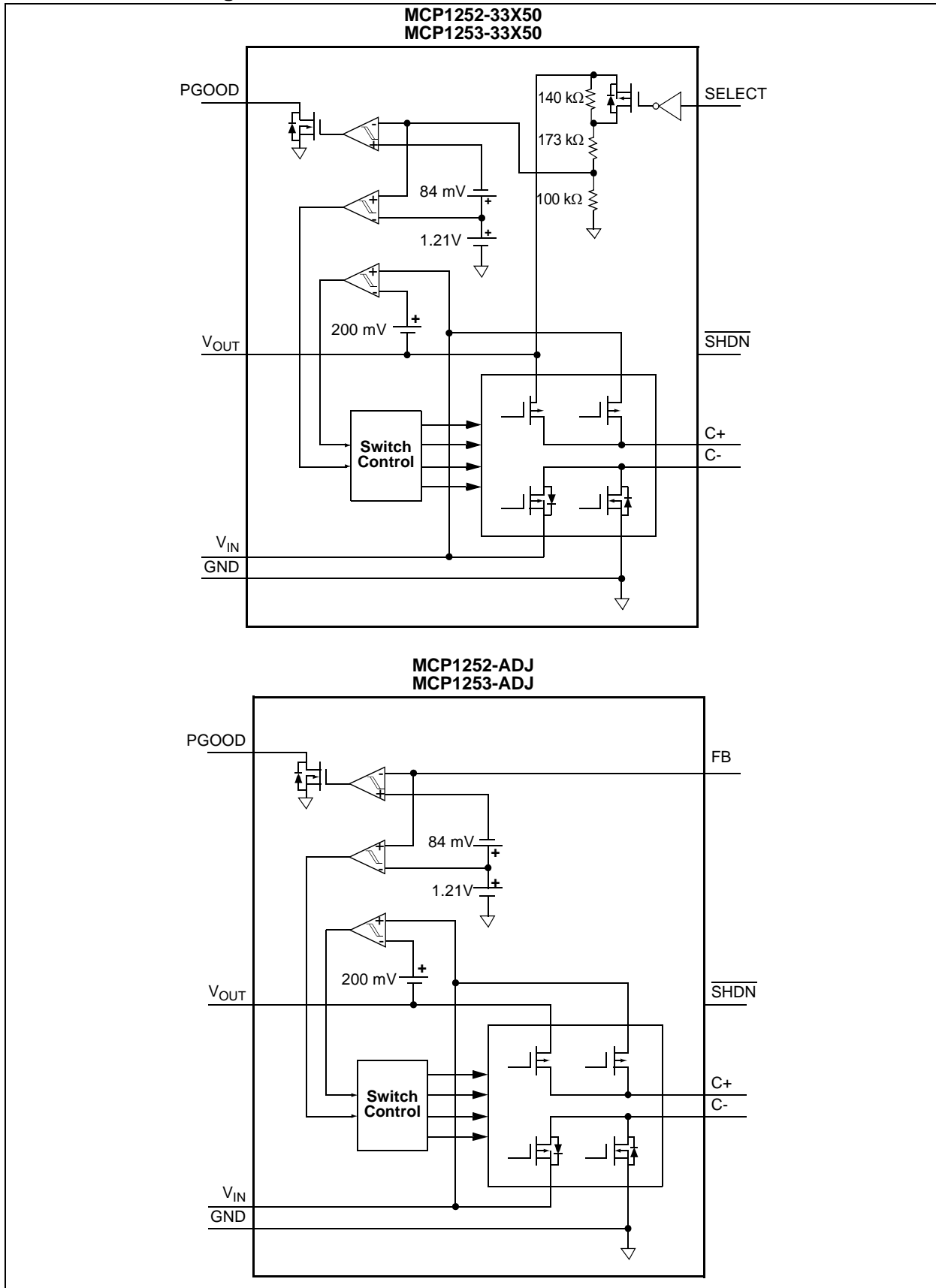

1.0 ELECTRICAL CHARACTERISTICS

Absolute Maximum Ratings †

Power Supply Voltage, V_{IN}6.0V
 Voltage on Any Pin w.r.t. GND -0.3V to ($V_{IN} + 0.3V$)
 Output Short Circuit Durationcontinuous
 Storage Temperature Range.....-65°C to +150°C
 Ambient Temperature with Power Applied-55°C to +125°C
 Junction Temperature +150°C

ESD Ratings:

Human Body Model (1.5 kΩ in Series with 100 pF).....≥ 4 kV
 Machine Body Model (200 pF, No Series Resistance)≥ 400V

†**Notice:** Stresses above those listed under "Maximum Ratings" may cause permanent damage to the device. This is a stress rating only and functional operation of the device at those or any other conditions above those indicated in the operational listings of this specification is not implied. Exposure to maximum rating conditions for extended periods may affect device reliability.

ELECTRICAL CHARACTERISTICS

Electrical Specifications: Unless otherwise specified, all limits are specified for $T_A = -40^\circ\text{C}$ to $+85^\circ\text{C}$ ("I" Temperature), $T_A = -40^\circ\text{C}$ to $+125^\circ\text{C}$ ("E" Temperature), $SHDN = V_{IN}$, $C_{IN} = C_{OUT} = 10 \mu\text{F}$, $C_{FLY} = 1 \mu\text{F}$, $I_{OUT} = 10 \text{ mA}$. Typical values are for $T_A = +25^\circ\text{C}$.

Parameters	Sym.	Min.	Typ.	Max.	Units	Conditions
Selectable Output - MCP1252-33X50, MCP1253-33X50: SELECT = V_{IN}, $V_{OUT} = 3.3V$						
Supply Voltage	V_{IN}	2.1	—	5.5	V	
Output Voltage Accuracy	V_{OUT}	-2.5	±0.5	+2.5	%	$2.3V \leq V_{IN} < 2.5V$, $I_{OUT} \leq 80 \text{ mA}$ $2.5V \leq V_{IN} \leq 5.5V$, $I_{OUT} \leq 120 \text{ mA}$
Output Current	I_{OUT}	80	100	—	mA	$2.3V \leq V_{IN} < 2.5V$
		120	150	—	mA	$2.5V \leq V_{IN} \leq 5.5V$
SELECT Logic Input Voltage High	V_{IH}	1.4	—	—	V	MCP1252-33X50, MCP1253-33X50
Selectable Output - MCP1252-33X50, MCP1253-33X50: SELECT = GND, $V_{OUT} = 5.0V$						
Supply Voltage	V_{IN}	2.7	—	5.5	V	
Output Voltage Accuracy	V_{OUT}	-2.5	±0.5	+2.5	%	$2.7V \leq V_{IN} < 3.0V$, $I_{OUT} \leq 40 \text{ mA}$ $3.0V \leq V_{IN} \leq 5.5V$, $I_{OUT} \leq 120 \text{ mA}$
Output Current	I_{OUT}	40	80	—	mA	$2.7V \leq V_{IN} < 3.0V$
		120	150	—	mA	$3.0V \leq V_{IN} \leq 5.5V$
SELECT Logic Input Voltage Low	V_{IL}	—	—	0.4	V	MCP1252-33X50, MCP1253-33X50
Adjustable Output - MCP1252-ADJ, MCP1253-ADJ						
Supply Voltage	V_{IN}	2.0	—	5.5	V	
Output Voltage Adjustment Range	V_{OUT}	1.5	—	5.5	V	$V_{OUT(MAX)} < 2 \times V_{IN}$
FB Regulation Voltage	V_{FB}	1.18	1.21	1.24	V	MCP1252-ADJ, MCP1253-ADJ
ALL DEVICES						
Supply Current	I_{DD}	—	60	120	μA	No load
Output Short-Circuit Current	I_{SC}	—	200	—	mA	$V_{OUT} = \text{GND}$, foldback current
Shutdown Current	I_{SHDN}	—	0.1	2.0	μA	$SHDN = 0V$
Power Efficiency	η	—	81	—	%	$V_{IN} = 3.0V$, $V_{OUT} = 5V$ $I_{OUT} = 120 \text{ mA}$
		—	68	—	%	$V_{IN} = 3.6V$, $V_{OUT} = 5V$ $I_{OUT} = 120 \text{ mA}$
SHDN Logic Input Voltage Low	V_{IL}	—	—	0.4	V	
SHDN Logic Input Voltage High	V_{IH}	1.4	—	—	V	
PGOOD Output Voltage	P_{GOOD_VOL}	—	0.01	—	V	$I_{PGOOD} = 0.5 \text{ mA}$
PGOOD Threshold Voltage	V_{TH}	—	$0.93V_{OUT}$	—	V	
PGOOD Hysteresis	V_{HYS}	—	$0.04V_{OUT}$	—	V	

MCP1252/3

AC CHARACTERISTICS

Electrical Specifications: Unless otherwise specified, all limits are specified for $T_A = -40^{\circ}\text{C}$ to $+85^{\circ}\text{C}$ ("I" Temperature), $T_A = -40^{\circ}\text{C}$ to $+125^{\circ}\text{C}$ ("E" Temperature), $\text{SHDN} = V_{\text{IN}}$, $C_{\text{IN}} = C_{\text{OUT}} = 10\ \mu\text{F}$, $C_{\text{FLY}} = 1\ \mu\text{F}$, $I_{\text{OUT}} = 10\ \text{mA}$. Typical values are for $T_A = +25^{\circ}\text{C}$.

Parameters	Sym.	Min.	Typ.	Max.	Units	Conditions	
Internal Oscillator Frequency	F_{OSC}	520	650	780	kHz	MCP1252	
		800	1000	1200		MCP1253	
Ripple Voltage	V_{RIP}	—	50	—	$\text{mV}_{\text{p-p}}$	MCP1252	
		—	45	—	$\text{mV}_{\text{p-p}}$	MCP1253	
V_{OUT} Wake-Up Time From Shutdown	T_{WKUP}				μsec	$V_{\text{IN}} = 3.6\text{V}$, $I_{\text{OUT}} = 10\ \text{mA}$, $\text{SHDN} = V_{\text{IH(MIN)}}$, V_{OUT} from 0 to 90% Nominal Regulated Output Voltage	
		—	200	—			SELECT = V_{IN}
		—	300	—			SELECT = GND

TEMPERATURE SPECIFICATIONS

Parameters	Symbol	Min.	Typ.	Max.	Units	Conditions
Temperature Ranges:						
Specified Temperature Range	T_A	-40	—	+85	$^{\circ}\text{C}$	"I" Temperature range
		-40	—	+125		"E" Temperature range
Maximum Operating Junction Temperature	T_J	—	—	+125	$^{\circ}\text{C}$	
Storage Temperature Range	T_A	-65	—	+150	$^{\circ}\text{C}$	
Thermal Package Resistances:						
Thermal Resistance, 8 Pin MSOP	θ_{JA}	—	206	—	$^{\circ}\text{C}/\text{W}$	Single-Layer SEMI G42-88 board, Natural Convection

2.0 TYPICAL PERFORMANCE CURVES

Note: The graphs and tables provided following this note are a statistical summary based on a limited number of samples and are provided for informational purposes only. The performance characteristics listed herein are not tested or guaranteed. In some graphs or tables, the data presented may be outside the specified operating range (e.g., outside specified power supply range) and therefore outside the warranted range.

Note: Unless otherwise indicated, $V_{IN} = 3.6V$, $T_A = 25^\circ C$, $C_{IN} = C_{OUT} = 10 \mu F$, $C_{FLY} = 1 \mu F$, all capacitors X7R ceramic.

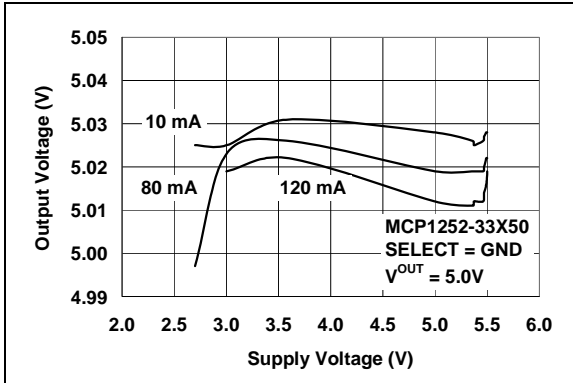

FIGURE 2-1: Output Voltage vs. Supply Voltage (MCP1252-33X50).

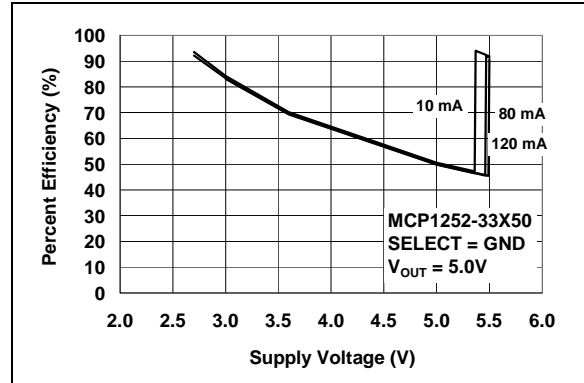

FIGURE 2-4: Percent Efficiency vs. Supply Voltage (MCP1252-33X50).

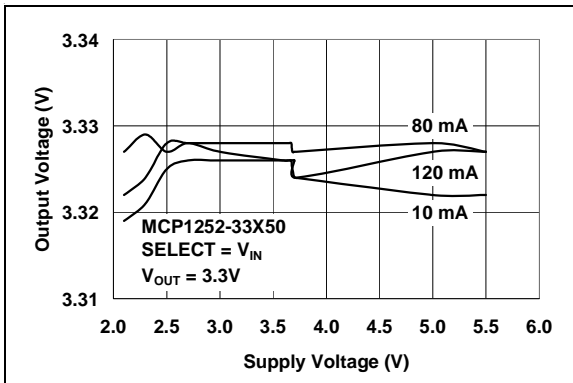

FIGURE 2-2: Output Voltage vs. Supply Voltage (MCP1252-33X50).

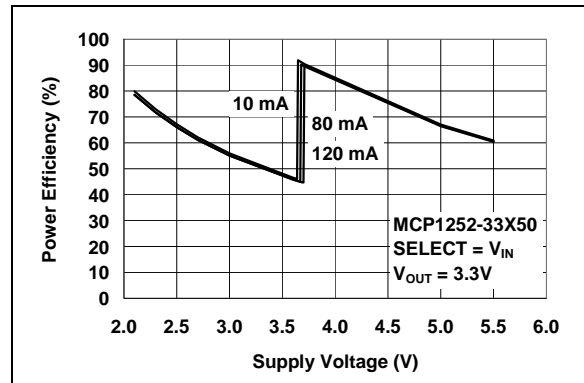

FIGURE 2-5: Power Efficiency vs. Supply Voltage (MCP1252-33X50).

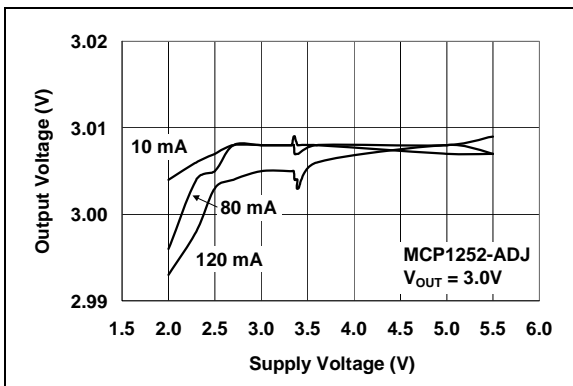

FIGURE 2-3: Output Voltage vs. Supply Voltage (MCP1252-ADJ).

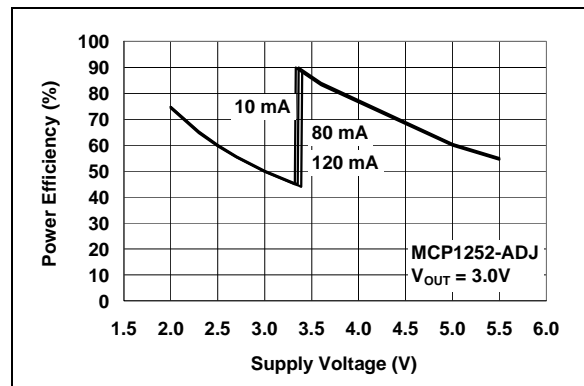

FIGURE 2-6: Power Efficiency vs. Supply Voltage (MCP1252-ADJ).

MCP1252/3

Note: Unless otherwise indicated, $V_{IN} = 3.6V$, $T_A = 25^\circ C$, $C_{IN} = C_{OUT} = 10\text{ mF}$, $C_{FLY} = 1\text{ mF}$, all capacitors X7R ceramic.

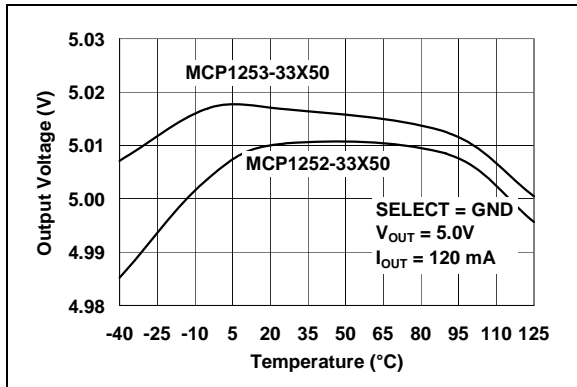

FIGURE 2-7: Output Voltage vs. Temperature (MCP1252-33X50, MCP1253-33X50).

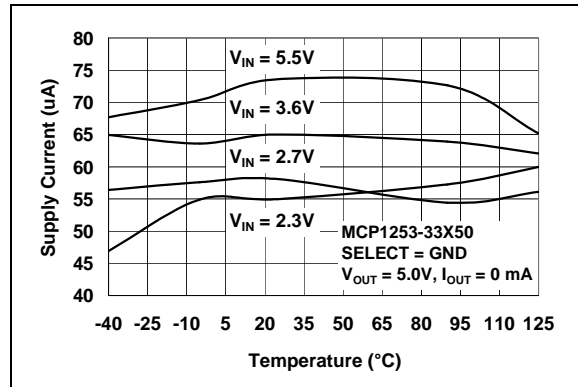

FIGURE 2-10: Quiescent Current vs. Temperature (MCP1253-33X50).

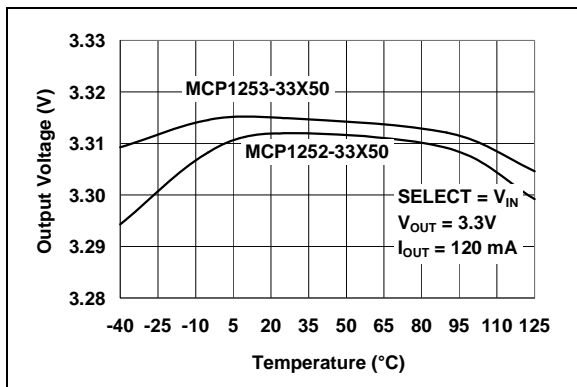

FIGURE 2-8: Output Voltage vs. Temperature (MCP1252-33X50, MCP1253-33X50).

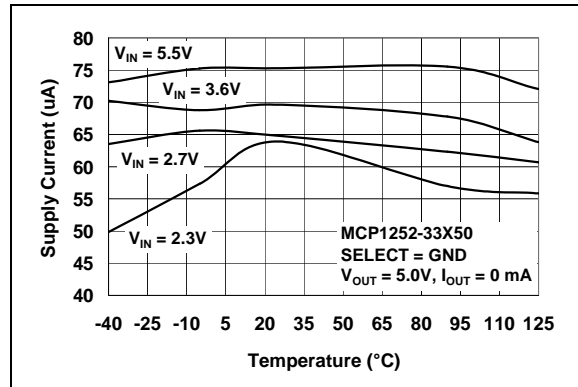

FIGURE 2-11: Quiescent Current vs. Temperature (MCP1252-33X50).

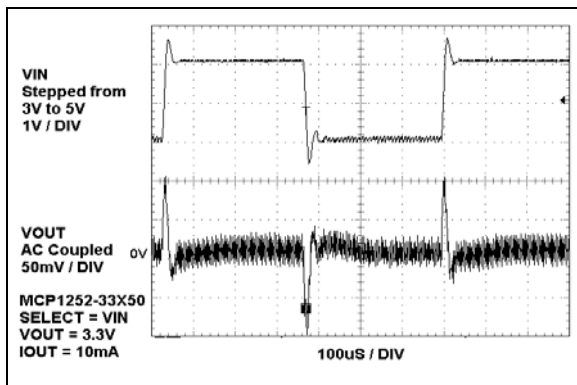

FIGURE 2-9: Line Transient Response.

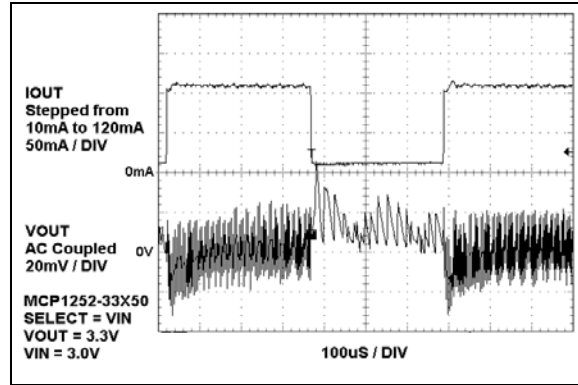

FIGURE 2-12: Load Transient Response.

Note: Unless otherwise indicated, $V_{IN} = 3.6V$, $T_A = 25^\circ C$, $C_{IN} = C_{OUT} = 10mF$, $C_{FLY} = 1mF$, all capacitors X7R ceramic.

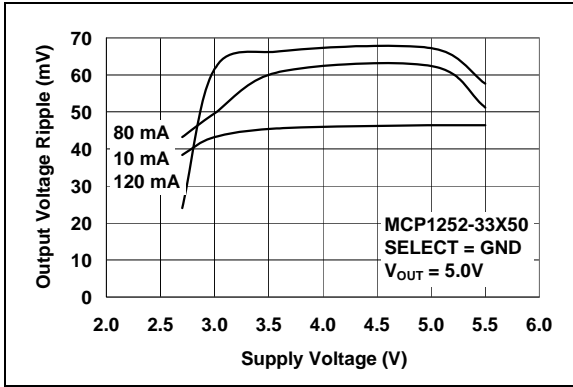

FIGURE 2-13: Output Voltage Ripple vs. Supply Voltage (MCP1252-33X50).

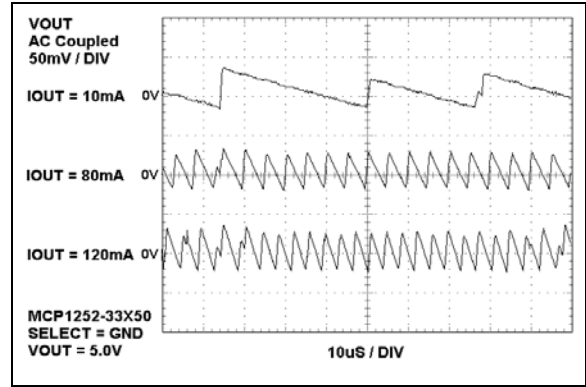

FIGURE 2-16: Output Voltage Ripple vs. Time.

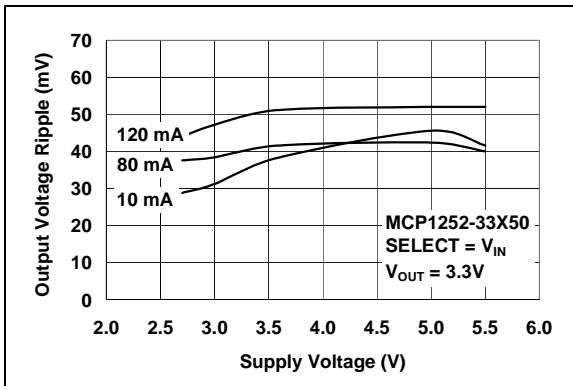

FIGURE 2-14: Output Voltage Ripple vs. Supply Voltage (MCP1252-33X50).

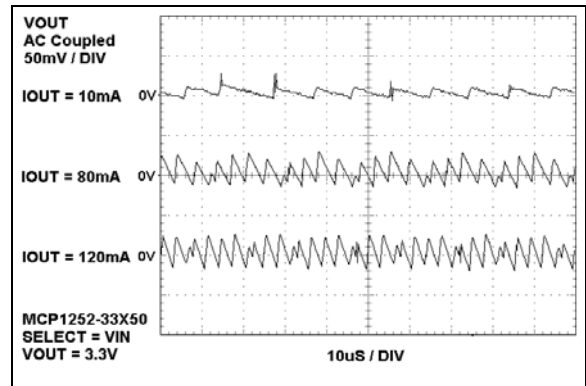

FIGURE 2-17: Output Voltage Ripple vs. Time.

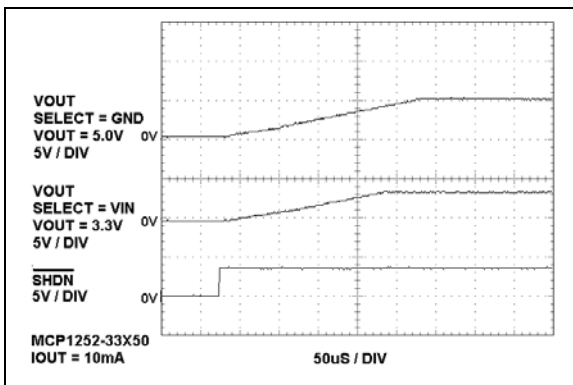

FIGURE 2-15: Start-Up (MCP1252-33X50).

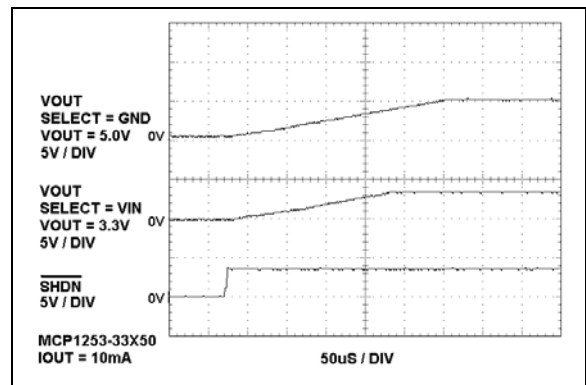

FIGURE 2-18: Start-Up (MCP1253-33X50).

MCP1252/3

3.0 PIN FUNCTIONS

The descriptions of the pins are listed in [Table 3-1](#).

TABLE 3-1: PIN FUNCTION TABLE

Pin No.	Name	Function
1	PGOOD	Open-Drain Power GOOD Output
2	V _{OUT}	Regulated Output Voltage
3	V _{IN}	Power Supply Input
4	GND	Ground Terminal
5	C-	Flying Capacitor Negative Terminal
6	C+	Flying Capacitor Positive Terminal
7	SHDN	Shutdown Mode, Active-Low Input
8	SELECT	Output Voltage Select Pin (MCP1252-33X50, MCP1253-33X50)
	FB	Feedback Input Pin for Adjustable Output (MCP1252-ADJ, MCP1253-ADJ)

3.1 Open-Drain Power Good Output (PGOOD)

PGOOD is a high-impedance when the output voltage is in regulation. A logic-low is asserted when the output falls 7% (typical) below the nominal value. The PGOOD output remains low until V_{OUT} is within 3% (typical) of its nominal value. On start-up, this pin indicates when the output voltage reaches its final value. PGOOD is high-impedance when SHDN is low.

3.2 Regulated Output Voltage (V_{OUT})

Bypass to GND with a filter capacitor.

3.3 Power Supply Input (V_{IN})

It is recommended that V_{IN} be tied to a ceramic bypass capacitor.

3.4 Ground (GND)

It is recommended that the ground pin be tied to a ground plane for best performance.

3.5 Flying Capacitor Negative Terminal (C-)

The charge pump capacitor (flying capacitor) is used to transfer charge from the input supply to the regulated output.

It is recommended that a low ESR (equivalent series resistance) capacitor be used.

3.6 Flying Capacitor Positive Terminal (C+)

The charge pump capacitor (flying capacitor) is used to transfer charge from the input supply to the regulated output.

Proper orientation is imperative when using a polarized capacitor.

3.7 Shutdown Input (SHDN)

A logic-low signal applied to SHDN disables the device. A logic-high signal applied to this pin allows normal operation.

3.8 Select (SELECT) Input or Feedback (FB) Input

MCP1252-33X50, MCP1253-33X50:

SELECT: Select Input Pin.

Connect SELECT to V_{IN} for 3.3V fixed output. Connect SELECT to GND for a 5.0V fixed output.

MCP1252-ADJ, MCP1253-ADJ:

FB: Feedback Pin.

A resistor divider connected to this pin determines the adjustable V_{OUT} value (1.5V to 5.5V).

4.0 DEVICE OVERVIEW

4.1 Theory of Operation

The MCP1252 and MCP1253 family of devices employ a switched capacitor charge pump to buck or boost an input supply voltage (V_{IN}) to a regulated output voltage. Referring to the Functional Block Diagram and Figure 4-1, the devices perform conversion and regulation in three phases. When the devices are not in shutdown mode and a steady-state condition has been reached, the three phases are continuously cycled through. The first phase transfers charge from the input to the flying capacitor (C_{FLY}) connected to pins C+ and C-. This phase always occurs for half of the internal oscillator period. During this phase, switches S_1 and S_2 are closed.

Once the first phase is complete, all switches are opened and the second phase (idle phase) is entered. The device compares the internal or external feedback voltage with an internal reference. If the feedback voltage is below the regulation point, the device transitions to the third phase.

The third phase transfers energy from the flying capacitor to the output capacitor connected to V_{OUT} and the load. If regulation is maintained, the device returns to the idle phase. If the charge transfer occurs for half the internal oscillator period, more charge is needed in the flying capacitor and the device transitions back to the first phase.

The regulation control is hysteretic, otherwise referred to as a bang-bang control. The output is regulated around a fixed reference with some hysteresis. As a result, typically 50 mV of peak-to-peak ripple will be observed at the output independent of load current. The frequency of the output ripple, however, will be influenced heavily by the load current and output capacitance. The maximum frequency that will be observed is equal to the internal oscillator frequency.

The devices automatically transition between buck or boost operation. This provides a low-cost, compact and simple solution for step-down/step-up DC/DC conversion. This is especially true for battery-operated applications that require a fixed output above or below the input.

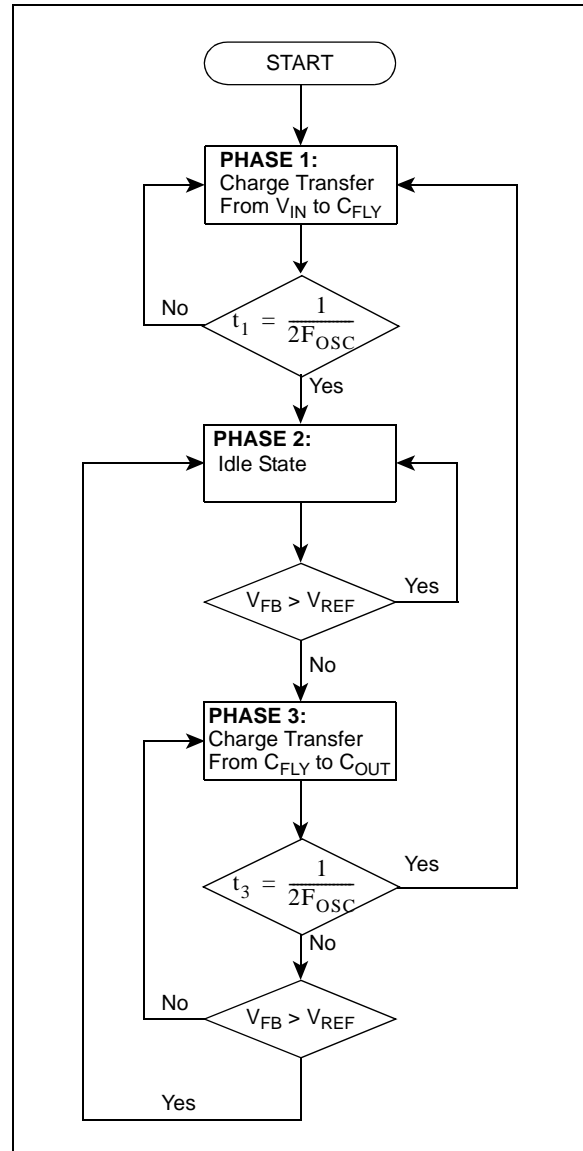

FIGURE 4-1: Flow Algorithm.

MCP1252/3

4.2 Power Efficiency

The power efficiency, η , is determined by the mode of operation. In boost mode, the efficiency is approximately half of a linear regulator. In buck mode, the efficiency is approximately equal to that of a linear regulator. The following formulas can be used to approximate the power efficiency with any significant amount of output current. At light loads, the quiescent current of the device must be taken into consideration.

EQUATION 4-1:

$$\eta_{BOOST} = \frac{P_{OUT}}{P_{IN}} = \frac{V_{OUT} \times I_{OUT}}{V_{IN} \times 2 \times I_{OUT}} = \frac{V_{OUT}}{V_{IN} \times 2}$$

$$\eta_{BUCK} = \frac{P_{OUT}}{P_{IN}} = \frac{V_{OUT} \times I_{OUT}}{V_{IN} \times I_{OUT}} = \frac{V_{OUT}}{V_{IN}}$$

4.3 Shutdown Mode

Driving \overline{SHDN} low places the MCP1252 or MCP1253 in a low-power shutdown mode. This disables the charge pump switches, oscillator and control logic, reducing the quiescent current to 0.1 μ A (typical). The PGOOD output is in a high-impedance state during shutdown.

4.4 PGOOD Output

The PGOOD output is an open-drain output that sinks current when the regulator output voltage falls below 0.93 V_{OUT} (typical). The output voltage can either be fixed when the selectable output device is chosen (MCP1252-33X50, MCP1253-33X50) or adjustable when the adjustable device is chosen (MCP1252-ADJ, MCP1253-ADJ). If the regulator output voltage falls below 0.93 V_{OUT} (typical) for less than 200 μ sec and then recovers, glitch-immunity circuits prevent the PGOOD signal from transitioning low. A 10 k Ω to 1 M Ω pull-up resistor from PGOOD to V_{OUT} may be used to provide a logic output. Connect PGOOD to GND or leave unconnected if not used.

4.5 Soft-Start and Short-Circuit Protection

The MCP1252 and MCP1253 feature foldback short-circuit protection. This circuitry provides an internal soft-start function by limiting in-rush current during startup and also limits the output current to 200 mA (typical) if the output is shorted to GND. The internal soft-start circuitry requires approximately 300 μ sec, typical with a 5V output, from either initial power-up or release from shutdown for the output voltage to be in regulation.

4.6 Thermal Shutdown

The MCP1252 and MCP1253 feature thermal shutdown with temperature hysteresis. When the die temperature exceeds 160°C, typically, the device shuts down. When the die cools by 15°C, typically, the device automatically turns back on. If high die temperature is caused by output overload and the load is not removed, the device will turn on and off, resulting in a pulse output.

5.0 APPLICATIONS

The MCP1252 and MCP1253 are inductorless, positive-regulated, charge pump DC/DC converters. A typical circuit configuration for the fixed output version is depicted in Figure 5-1. The adjustable version is depicted in Figure 5-2.

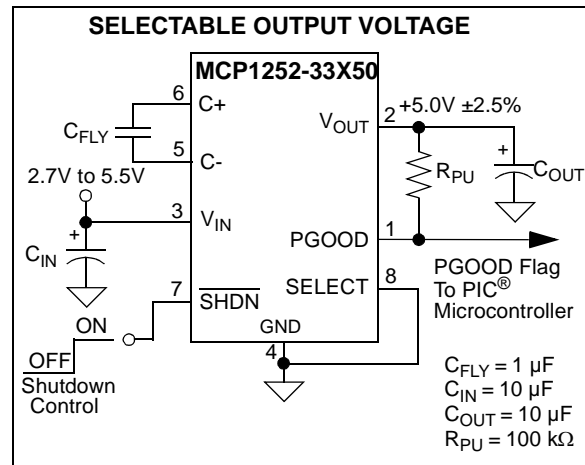

FIGURE 5-1: Typical Circuit Configuration for Fixed Output Device.

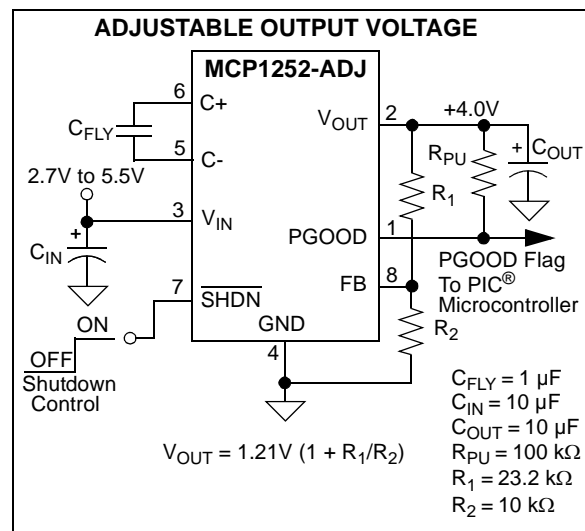

FIGURE 5-2: Typical Circuit Configuration for Adjustable Output Device.

5.1 Capacitor Selection

The style and value of capacitors used with the MCP1252 and MCP1253 family of devices determine several important parameters such as output voltage ripple and charge pump strength. To minimize noise and ripple, it is recommended that low ESR (0.1 Ω) capacitors be used for both C_{IN} and C_{OUT} . These capacitors should be either ceramic or tantalum and should be 10 μF or higher. Aluminum capacitors are not recommended because of their high ESR.

If the source impedance to V_{IN} is very low, up to several megahertz, C_{IN} may not be required. Alternatively, a somewhat smaller value of C_{IN} may be substituted for the recommended 10 μF , but will not be as effective in preventing ripple on the V_{IN} pin.

The value of C_{OUT} controls the amount of output voltage ripple present on V_{OUT} . Increasing the size of C_{OUT} will reduce output ripple at the expense of a slower turn-on time from shutdown and a higher in-rush current.

The flying capacitor (C_{FLY}) controls the strength of the charge pump. In order to achieve the maximum rated output current (120 mA), it is necessary to have at least 1 μF of capacitance for the flying capacitor. A smaller flying capacitor delivers less charge per clock cycle to the output capacitor, resulting in lower output ripple. The output ripple is reduced at the expense of maximum output current and efficiency.

5.2 Output Voltage Setting

The MCP1252-33X50 and MCP1253-33X50 feedback controllers select between an internally-set, regulated output voltage (3.3V or 5.0V). Connect SELECT to GND for a regulated 5.0V output and connect SELECT to V_{IN} for a regulated 3.3V output.

The MCP1252-ADJ and MCP1253-ADJ utilize an external resistor divider that allows the output voltage to be adjusted between 1.5V and 5.5V. For an adjustable output, connect a resistor between V_{OUT} and FB (R_1) and another resistor between FB and GND (R_2). In the following equation, choose R_2 to be less than or equal to 30 k Ω and calculate R_1 from the following formula:

EQUATION 5-1:

$$R_1 = R_2[(V_{OUT}/V_{FB}) - 1]$$

and:

EQUATION 5-2:

$$V_{OUT} = V_{FB}(1 + R_1/R_2)$$

where:

V_{OUT} is the desired output voltage from 1.5V to 5.5V

V_{FB} is the internal regulation voltage, nominally 1.21V

Note that the tolerance of the external resistors will have an effect on the accuracy of the output voltage. For optimum results, it is recommended that the external resistors have a tolerance no larger than 1%.

5.3 Recommended Layout

The MCP1252 and MCP1253 family of devices transfer charge at high switching frequencies, producing fast, high peak, transient currents. As a result, any stray inductance in the component layout will produce unwanted noise in the system. Proper board layout techniques are required to ensure optimum performance. Figure 5-3 depicts the recommended board layout. The input capacitor connected between V_{IN} and GND, and the output capacitor connected between V_{OUT} and GND, are 10 μF ceramic, X7R dielectric, in 1206 packages. The flying capacitor connected between C+ and C- is a 1 μF ceramic, X7R dielectric in a 0805 package. The layout is scaled 3:1.

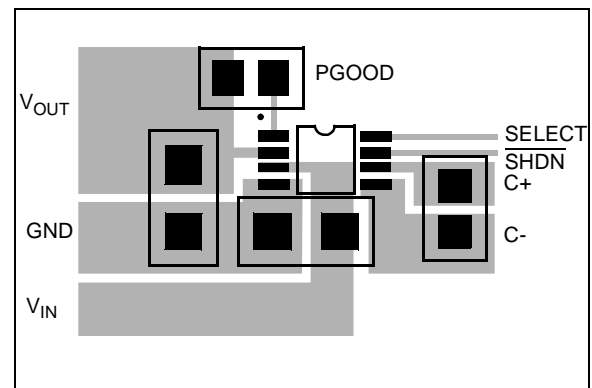
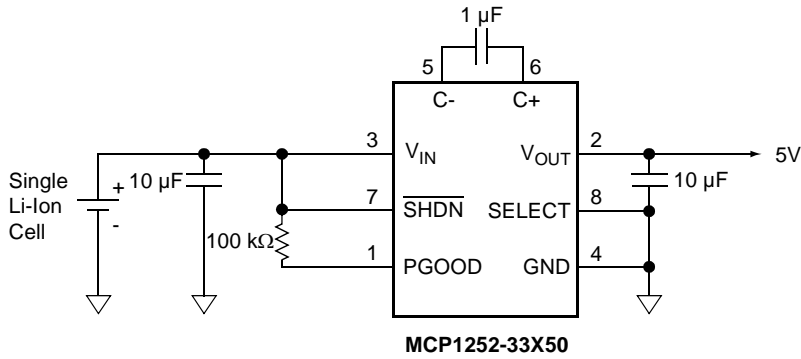

FIGURE 5-3: Recommended Printed Circuit Board Layout.

MCP1252/3

6.0 TYPICAL APPLICATION CIRCUITS

Single Cell Lithium-Ion Battery To 5V Converter



White LED Bias

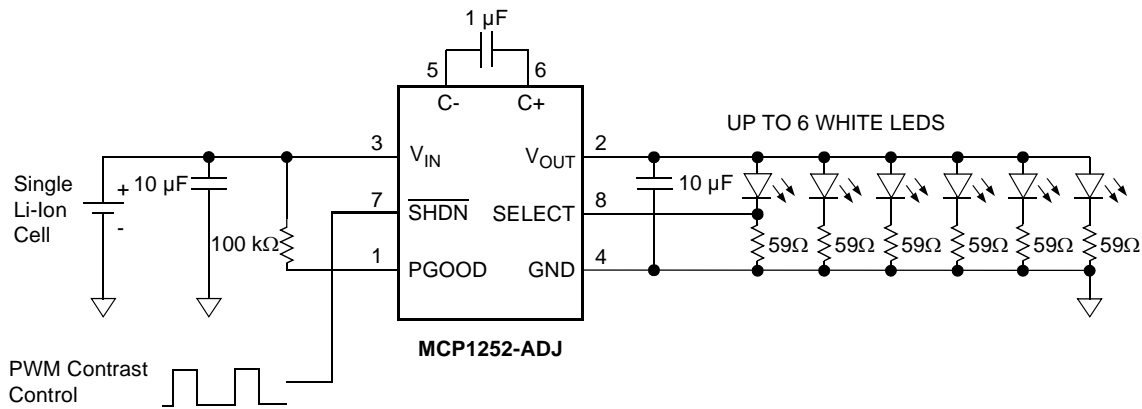

Alternative White LED Bias

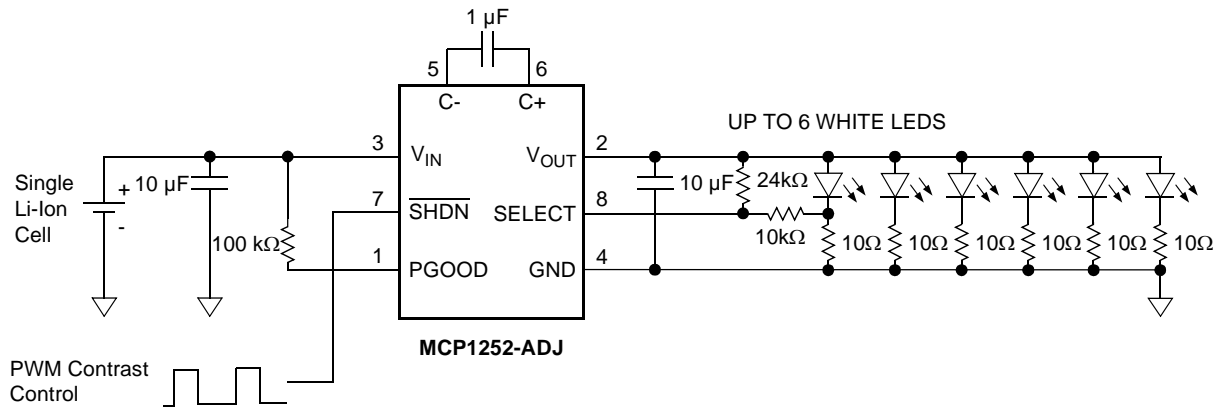

7.0 PACKAGING INFORMATION

7.1 Package Marking

8-Lead MSOP (Fixed)

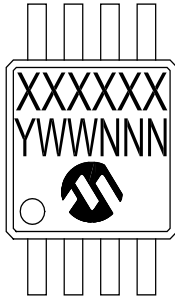

Example:

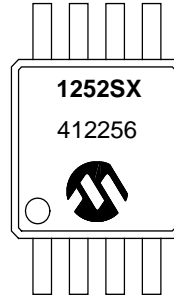

8-Lead MSOP (Adjustable)

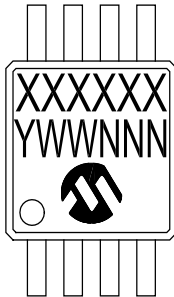

Example:

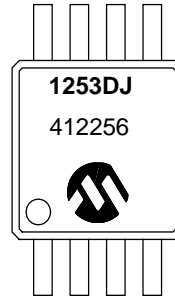

OR



Legend:	XX...X	Customer-specific information
	Y	Year code (last digit of calendar year)
	YY	Year code (last 2 digits of calendar year)
	WW	Week code (week of January 1 is week '01')
	NNN	Alphanumeric traceability code
	(e3)	Pb-free JEDEC® designator for Matte Tin (Sn)
	*	This package is Pb-free. The Pb-free JEDEC designator (e3) can be found on the outer packaging for this package.

Note: In the event the full Microchip part number cannot be marked on one line, it will be carried over to the next line, thus limiting the number of available characters for customer-specific information.

MCP1252/3

8-Lead Plastic Micro Small Outline Package (MS) [MSOP]

Note: For the most current package drawings, please see the Microchip Packaging Specification located at <http://www.microchip.com/packaging>

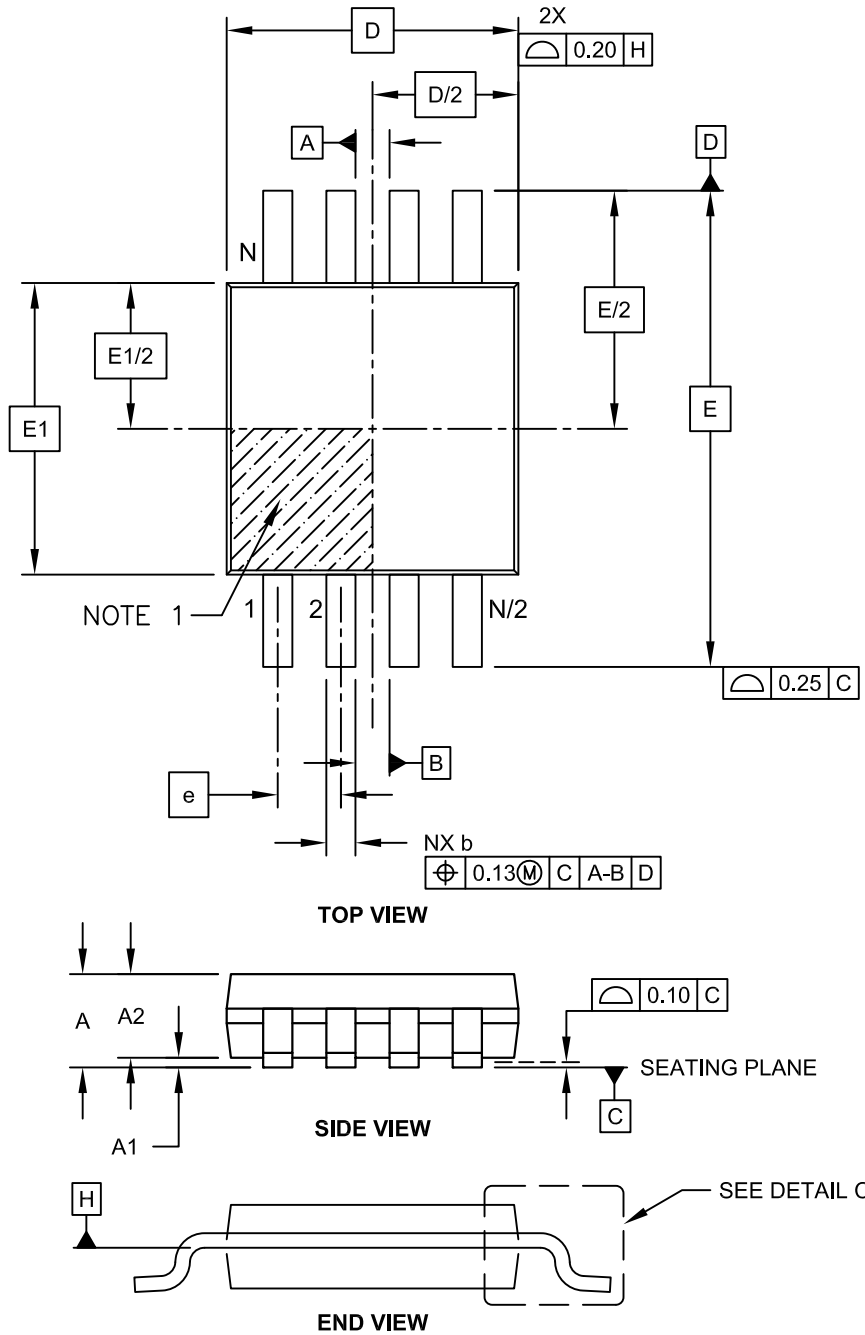

Microchip Technology Drawing C04-111C Sheet 1 of 2

8-Lead Plastic Micro Small Outline Package (MS) [MSOP]

Note: For the most current package drawings, please see the Microchip Packaging Specification located at <http://www.microchip.com/packaging>

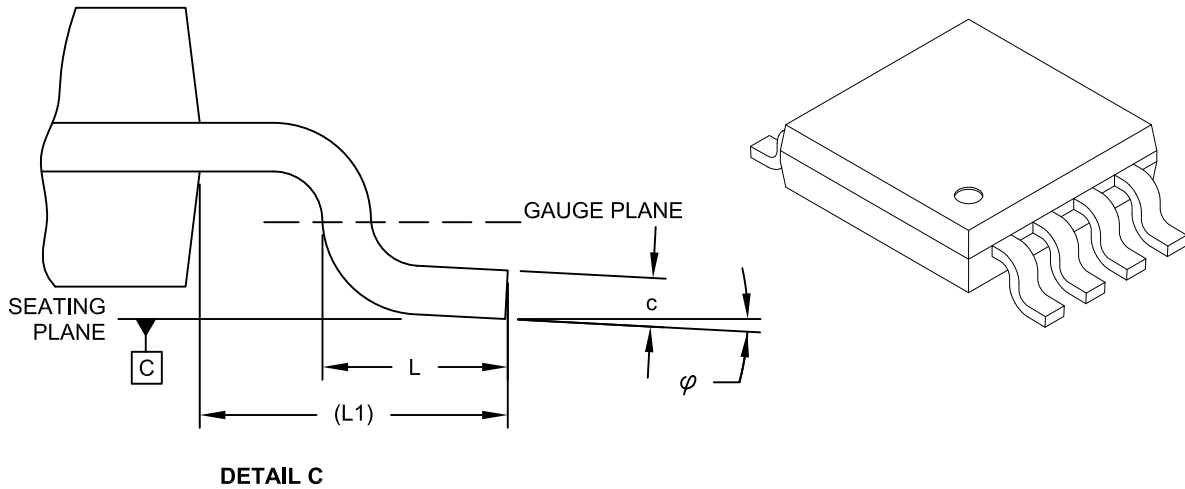

Dimension Limits	Units	MILLIMETERS		
		MIN	NOM	MAX
Number of Pins	N		8	
Pitch	e	0.65 BSC		
Overall Height	A	-	-	1.10
Molded Package Thickness	A2	0.75	0.85	0.95
Standoff	A1	0.00	-	0.15
Overall Width	E	4.90 BSC		
Molded Package Width	E1	3.00 BSC		
Overall Length	D	3.00 BSC		
Foot Length	L	0.40	0.60	0.80
Footprint	L1	0.95 REF		
Foot Angle	φ	0°	-	8°
Lead Thickness	c	0.08	-	0.23
Lead Width	b	0.22	-	0.40

Notes:

- Pin 1 visual index feature may vary, but must be located within the hatched area.
- Dimensions D and E1 do not include mold flash or protrusions. Mold flash or protrusions shall not exceed 0.15mm per side.
- Dimensioning and tolerancing per ASME Y14.5M.
 BSC: Basic Dimension. Theoretically exact value shown without tolerances.
 REF: Reference Dimension, usually without tolerance, for information purposes only.

Microchip Technology Drawing C04-111C Sheet 2 of 2

MCP1252/3

8-Lead Plastic Micro Small Outline Package (MS) [MSOP]

Note: For the most current package drawings, please see the Microchip Packaging Specification located at <http://www.microchip.com/packaging>

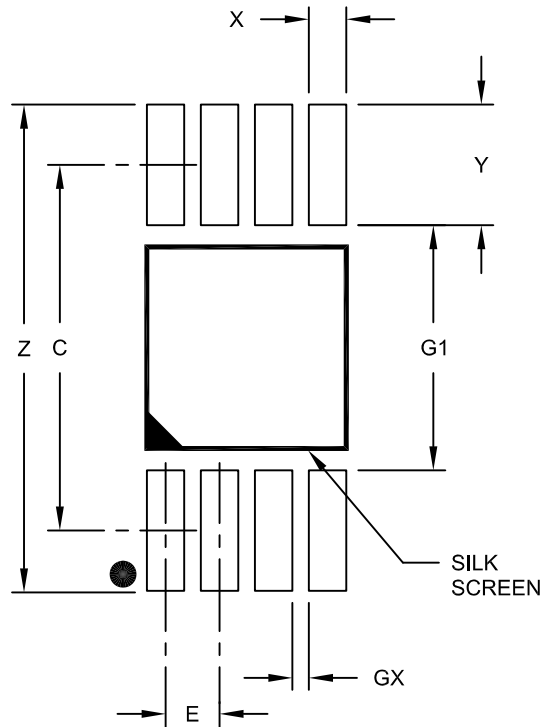

RECOMMENDED LAND PATTERN

Dimension Limits	Units	MILLIMETERS		
		MIN	NOM	MAX
Contact Pitch	E	0.65 BSC		
Contact Pad Spacing	C		4.40	
Overall Width	Z			5.85
Contact Pad Width (X8)	X1			0.45
Contact Pad Length (X8)	Y1			1.45
Distance Between Pads	G1	2.95		
Distance Between Pads	GX	0.20		

Notes:

1. Dimensioning and tolerancing per ASME Y14.5M

BSC: Basic Dimension. Theoretically exact value shown without tolerances.

Microchip Technology Drawing No. C04-2111A

APPENDIX A: REVISION HISTORY

Revision C (July 2014)

The following is the list of modifications:

1. Added the Extended Temperature (E) option and related information throughout the document.

Revision B (January 2013)

The following is the list of modifications:

1. Added a note to each package outline drawing.

MCP1252/3

PRODUCT IDENTIFICATION SYSTEM

To order or obtain information, e.g., on pricing or delivery, refer to the factory or the listed sales office.

PART NO. Device	[X] ⁽¹⁾ Tape and Reel Option	-XXX Voltage Option	X Temperature Range	/XX Package	
<p>MCP1252: Low-Noise, Positive-Regulated Charge Pump MCP1252T: Low-Noise, Positive-Regulated Charge Pump (Tape and Reel) MCP1253: Low-Noise, Positive-Regulated Charge Pump MCP1253T: Low-Noise, Positive-Regulated Charge Pump (Tape and Reel)</p> <p>Tape and Reel Option: T = Tape and Reel⁽¹⁾</p> <p>Output Voltage: ADJ = Adjustable Voltage 33X50 = Selectable Voltage</p> <p>Temperature Range: I = -40°C to +85°C (Industrial) E = -40°C to +125°C (Extended) (MCP1253 only)</p> <p>Package: MS = Plastic Micro Small Outline (MSOP), 8-lead</p>					<p>Examples:</p> <p>a) MCP1252-33X50I/MS: Low-Noise, Positive-Regulated Charge Pump, Fixed Output b) MCP1252-ADJI/MS: Low-Noise, Positive-Regulated Charge Pump, Adjustable Output c) MCP1252T-33X50I/MS: Tape and Reel, Low-Noise, Positive-Regulated Charge Pump, Fixed Output</p> <p>a) MCP1253-33X50I/MS: Low-Noise, Positive-Regulated Charge Pump, Fixed Output b) MCP1253-ADJI/MS: Low-Noise, Positive-Regulated Charge Pump, Adjustable Output c) MCP1253T-ADJI/MS: Tape and Reel, Low-Noise, Positive-Regulated Charge Pump, Adjustable Output</p> <p>Note 1: Tape and Reel identifier only appears in the catalog part number description. This identifier is used for ordering purposes and is not printed on the device package. Check with your Microchip Sales Office for package availability with the Tape and Reel option.</p>

Note the following details of the code protection feature on Microchip devices:

- Microchip products meet the specification contained in their particular Microchip Data Sheet.
- Microchip believes that its family of products is one of the most secure families of its kind on the market today, when used in the intended manner and under normal conditions.
- There are dishonest and possibly illegal methods used to breach the code protection feature. All of these methods, to our knowledge, require using the Microchip products in a manner outside the operating specifications contained in Microchip's Data Sheets. Most likely, the person doing so is engaged in theft of intellectual property.
- Microchip is willing to work with the customer who is concerned about the integrity of their code.
- Neither Microchip nor any other semiconductor manufacturer can guarantee the security of their code. Code protection does not mean that we are guaranteeing the product as “unbreakable.”

Code protection is constantly evolving. We at Microchip are committed to continuously improving the code protection features of our products. Attempts to break Microchip's code protection feature may be a violation of the Digital Millennium Copyright Act. If such acts allow unauthorized access to your software or other copyrighted work, you may have a right to sue for relief under that Act.

Information contained in this publication regarding device applications and the like is provided only for your convenience and may be superseded by updates. It is your responsibility to ensure that your application meets with your specifications. MICROCHIP MAKES NO REPRESENTATIONS OR WARRANTIES OF ANY KIND WHETHER EXPRESS OR IMPLIED, WRITTEN OR ORAL, STATUTORY OR OTHERWISE, RELATED TO THE INFORMATION, INCLUDING BUT NOT LIMITED TO ITS CONDITION, QUALITY, PERFORMANCE, MERCHANTABILITY OR FITNESS FOR PURPOSE. Microchip disclaims all liability arising from this information and its use. Use of Microchip devices in life support and/or safety applications is entirely at the buyer's risk, and the buyer agrees to defend, indemnify and hold harmless Microchip from any and all damages, claims, suits, or expenses resulting from such use. No licenses are conveyed, implicitly or otherwise, under any Microchip intellectual property rights.

Trademarks

The Microchip name and logo, the Microchip logo, dsPIC, FlashFlex, flexPWR, JukeBlox, KEELOQ, KEELOQ logo, Klear, LANCheck, MediaLB, MOST, MOST logo, MPLAB, OptoLyzer, PIC, PICSTART, PIC³² logo, RightTouch, SpyNIC, SST, SST Logo, SuperFlash and UNI/O are registered trademarks of Microchip Technology Incorporated in the U.S.A. and other countries.

The Embedded Control Solutions Company and mTouch are registered trademarks of Microchip Technology Incorporated in the U.S.A.

Analog-for-the-Digital Age, BodyCom, chipKIT, chipKIT logo, CodeGuard, dsPICDEM, dsPICDEM.net, ECAN, In-Circuit Serial Programming, ICSP, Inter-Chip Connectivity, KlearNet, KlearNet logo, MiWi, MPASM, MPF, MPLAB Certified logo, MPLIB, MPLINK, MultiTRAK, NetDetach, Omniscient Code Generation, PICDEM, PICDEM.net, PICkit, PICtail, RightTouch logo, REAL ICE, SQI, Serial Quad I/O, Total Endurance, TSHARC, USBCheck, VariSense, ViewSpan, WiperLock, Wireless DNA, and ZENA are trademarks of Microchip Technology Incorporated in the U.S.A. and other countries.

SQTP is a service mark of Microchip Technology Incorporated in the U.S.A.

Silicon Storage Technology is a registered trademark of Microchip Technology Inc. in other countries.

GestIC is a registered trademarks of Microchip Technology Germany II GmbH & Co. KG, a subsidiary of Microchip Technology Inc., in other countries.

All other trademarks mentioned herein are property of their respective companies.

© 2002-2014, Microchip Technology Incorporated, Printed in the U.S.A., All Rights Reserved.

ISBN: 978-1-63276-373-0

QUALITY MANAGEMENT SYSTEM
CERTIFIED BY DNV
== ISO/TS 16949 ==

Microchip received ISO/TS-16949:2009 certification for its worldwide headquarters, design and wafer fabrication facilities in Chandler and Tempe, Arizona; Gresham, Oregon and design centers in California and India. The Company's quality system processes and procedures are for its PIC® MCUs and dsPIC® DSCs, KEELOQ® code hopping devices, Serial EEPROMs, microperipherals, nonvolatile memory and analog products. In addition, Microchip's quality system for the design and manufacture of development systems is ISO 9001:2000 certified.



MICROCHIP

Worldwide Sales and Service

AMERICAS

Corporate Office
2355 West Chandler Blvd.
Chandler, AZ 85224-6199
Tel: 480-792-7200
Fax: 480-792-7277
Technical Support:
<http://www.microchip.com/support>
Web Address:
www.microchip.com

Atlanta
Duluth, GA
Tel: 678-957-9614
Fax: 678-957-1455

Austin, TX
Tel: 512-257-3370

Boston
Westborough, MA
Tel: 774-760-0087
Fax: 774-760-0088

Chicago
Itasca, IL
Tel: 630-285-0071
Fax: 630-285-0075

Cleveland
Independence, OH
Tel: 216-447-0464
Fax: 216-447-0643

Dallas
Addison, TX
Tel: 972-818-7423
Fax: 972-818-2924

Detroit
Novi, MI
Tel: 248-848-4000

Houston, TX
Tel: 281-894-5983

Indianapolis
Noblesville, IN
Tel: 317-773-8323
Fax: 317-773-5453

Los Angeles
Mission Viejo, CA
Tel: 949-462-9523
Fax: 949-462-9608

New York, NY
Tel: 631-435-6000

San Jose, CA
Tel: 408-735-9110

Canada - Toronto
Tel: 905-673-0699
Fax: 905-673-6509

ASIA/PACIFIC

Asia Pacific Office
Suites 3707-14, 37th Floor
Tower 6, The Gateway
Harbour City, Kowloon
Hong Kong
Tel: 852-2943-5100
Fax: 852-2401-3431

Australia - Sydney
Tel: 61-2-9868-6733
Fax: 61-2-9868-6755

China - Beijing
Tel: 86-10-8569-7000
Fax: 86-10-8528-2104

China - Chengdu
Tel: 86-28-8665-5511
Fax: 86-28-8665-7889

China - Chongqing
Tel: 86-23-8980-9588
Fax: 86-23-8980-9500

China - Hangzhou
Tel: 86-571-8792-8115
Fax: 86-571-8792-8116

China - Hong Kong SAR
Tel: 852-2943-5100
Fax: 852-2401-3431

China - Nanjing
Tel: 86-25-8473-2460
Fax: 86-25-8473-2470

China - Qingdao
Tel: 86-532-8502-7355
Fax: 86-532-8502-7205

China - Shanghai
Tel: 86-21-5407-5533
Fax: 86-21-5407-5066

China - Shenyang
Tel: 86-24-2334-2829
Fax: 86-24-2334-2393

China - Shenzhen
Tel: 86-755-8864-2200
Fax: 86-755-8203-1760

China - Wuhan
Tel: 86-27-5980-5300
Fax: 86-27-5980-5118

China - Xian
Tel: 86-29-8833-7252
Fax: 86-29-8833-7256

China - Xiamen
Tel: 86-592-2388138
Fax: 86-592-2388130

China - Zhuhai
Tel: 86-756-3210040
Fax: 86-756-3210049

ASIA/PACIFIC

India - Bangalore
Tel: 91-80-3090-4444
Fax: 91-80-3090-4123

India - New Delhi
Tel: 91-11-4160-8631
Fax: 91-11-4160-8632

India - Pune
Tel: 91-20-3019-1500

Japan - Osaka
Tel: 81-6-6152-7160
Fax: 81-6-6152-9310

Japan - Tokyo
Tel: 81-3-6880-3770
Fax: 81-3-6880-3771

Korea - Daegu
Tel: 82-53-744-4301
Fax: 82-53-744-4302

Korea - Seoul
Tel: 82-2-554-7200
Fax: 82-2-558-5932 or
82-2-558-5934

Malaysia - Kuala Lumpur
Tel: 60-3-6201-9857
Fax: 60-3-6201-9859

Malaysia - Penang
Tel: 60-4-227-8870
Fax: 60-4-227-4068

Philippines - Manila
Tel: 63-2-634-9065
Fax: 63-2-634-9069

Singapore
Tel: 65-6334-8870
Fax: 65-6334-8850

Taiwan - Hsin Chu
Tel: 886-3-5778-366
Fax: 886-3-5770-955

Taiwan - Kaohsiung
Tel: 886-7-213-7830

Taiwan - Taipei
Tel: 886-2-2508-8600
Fax: 886-2-2508-0102

Thailand - Bangkok
Tel: 66-2-694-1351
Fax: 66-2-694-1350

EUROPE

Austria - Wels
Tel: 43-7242-2244-39
Fax: 43-7242-2244-393

Denmark - Copenhagen
Tel: 45-4450-2828
Fax: 45-4485-2829

France - Paris
Tel: 33-1-69-53-63-20
Fax: 33-1-69-30-90-79

Germany - Dusseldorf
Tel: 49-2129-3766400

Germany - Munich
Tel: 49-89-627-144-0
Fax: 49-89-627-144-44

Germany - Pforzheim
Tel: 49-7231-424750

Italy - Milan
Tel: 39-0331-742611
Fax: 39-0331-466781

Italy - Venice
Tel: 39-049-7625286

Netherlands - Drunen
Tel: 31-416-690399
Fax: 31-416-690340

Poland - Warsaw
Tel: 48-22-3325737

Spain - Madrid
Tel: 34-91-708-08-90
Fax: 34-91-708-08-91

Sweden - Stockholm
Tel: 46-8-5090-4654

UK - Wokingham
Tel: 44-118-921-5800
Fax: 44-118-921-5820

03/25/14

单击下面可查看定价，库存，交付和生命周期等信息

[>>Microchip Technology](#)