

SPECIFICATION FOR APPROVAL

CUSTOMER : _____

PRODUCT TYPE : SMD TSX 2.5 * 2.0

NOMINAL FREQ. : 26 MHz

TXC P/N : OZ26000004

REVISION : S5

CUSTOMER P/N : _____

PM / SALES : _____

DATE : _____

CUSTOMER SIGNATURE & DATE
: _____

- (1) TXC requires one copy returned with signature and title of authorized individual that signifies acceptance of the attached specifications.
- (2) Orders received and accepted by TXC after return of signed copy of specification will be produced per these specifications.
- (3) Any changes to these specifications must be agreed upon by both parties and new revision of the Product Specification Sheet will be issued.
- (4) Any issuance of purchase order prior to consigning back the Approval page of "Specification Sheets" from customers will be regarded as the agreement on the contents of these specifications.

Attachment(s):

- 1. Product Specification Sheet
- 2. Testing Report(Electrical & Temperature)
- 3. Reliability Report

RoHS Compliant

PRODUCT SPECIFICATION SHEET

CUSTOMER : _____
PRODUCT TYPE : SMD TSX 2.5 * 2.0
NOMINAL FREQ. : 26 MHz
TXC P/N : OZ26000004
REVISION : S5

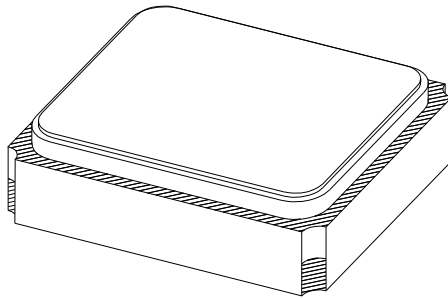

PE/RD	QA	MFG
Bruce Hsu		
Bruce Hsu		
6-Feb-13		

NOTE:

- (1) Lead Free Products are " Directive 2002 / 95 / EC of The European Parliament of 27 January 2003 on the restriction of the use of certain hazardous substances (RoHS) in electrical and electronic equipment" Compliant (Attachment: SGS Test Report).
- (2) Revision "Sx" is for engineering samples only. PE/RD's approval required.
- (3) Revision "Ax" is production ready. PE, QA and MFG's approval required.

RoHS Compliant

CRYSTAL ELECTRICAL SPECIFICATIONS

Standard Atmospheric Conditions

Unless otherwise specified, the standard range of atmospheric conditions for making measurement and tests are as follow:

Ambient temperature : 25±10°C
 Relative humidity : 40%~70%

If there is any doubt about the results, measurement shall be made within the following limits:

Ambient temperature : 25±3°C
 Relative humidity : 40%~70%

Measurement Equipment

Electrical characteristics measured by HP E5100A or equivalent

Crystal Cutting Type

The crystal is using AT CUT (thickness shear mode)

	Parameters	Symbol	Condition	Electrical Spec.				Note
				Min.	Typ.	Max.	Units	
1	Nominal Frequency	FL	-	26.000000			MHz	
2	Oscillation Mode	-	-	Fundamental				
3	Load Capacitance	CL	-	-	7	-	pF	
4	Frequency Tolerance	-	+25°C ± 3°C	±10			ppm	
5	Frequency Stability Over Operating Temp. Range(Reference 25°C)	-	-25 to +85°C	±10			ppm	
6	Operating Temperature	-	-	-30	~	+85	°C	
7	Aging	-	first year	±1.0			ppm	
		-	second year	±1.5			ppm	
		-	after 5 years	±2.5			ppm	
		-	after 10 years	±5.0			ppm	
8	Drive Level	DL	-	-	-	100	µW	
9	Equivalent Series Resistance	ESR	-	-	-	30	Ω	
10	Spurious Mode Resistance	-	±1 MHz	500	-	-	Ω	
11	Insulation Resistance	-	at DC 100V	500	-	-	MΩ	
12	Storage Temperature Range	-	-	-40	-	+85	°C	
13	DLD2	-	-	-	-	2.5	Ohms	1
14	FULD	-	-	-	-	2.0	Ohms	
15	DLDH2	-	-	-	-	1.5	ppm	
16	FULDH	-	-	-	-	0.7	ppm	
17	Pulling Sensitivity	TS	-	28±10%			ppm/pF	
18	Frequency Perturbation	-	-	-	-	±0.5	ppm	5
19	G Sensitivity	-	-	-	-	2	ppb/g	2
20	Small Cycle Temperature Hysteresis	-	-	±0.05			ppm	3
21	Full Cycle Temperature Hysteresis	-	-	-	-	0.5	ppm	4
22	S curve 3 order curve fitting coefficient (T0=25°C)	C1	-	-0.35	-0.22	-0.1	ppm/°C	
		C2	-	-0.0012	-0.0009	-0.0005	ppm/°C ²	
		C3	-	0.000087	0.000099	0.00011	ppm/°C ³	
23	Residual slope (3 order curve fitting under per 2°C test)	-	-10°C~60°C	±0.05			ppm	
		-	-30°C ~85°C	±0.1			ppm	

Note 1 10nW~100uW, step ratio is $\sqrt{10}$

Note 2 Gamma vector of all three axes from 30 Hz to 1.5 KHz (guarantee by design)

Note 3 Difference in freq. measurement at any temperature when undergoing a thermal cycle of a temperature range of 5°C for each 1 degree test(guarantee by design)(overall <100 ppb)

Note 4 Difference in freq. measurement at any temperature when undergoing a thermal cycle over the entire operation temperature range from -40°C to +85°C for each 2 degree (guarantee by design)

Note 5 Residual error from the freq. vs. temperature curve fit 3rd order. Min. of 1 freq. reading per 2 degree C over operation temperature

■ NTC THERMISTOR ELECTRICAL SPECIFICATIONS

	Parameters	Symbol	Condition	Electrical Spec.				Note
				Min.	Typ.	Max.	Units	
1	Resistance (25 °C)			100k ± 1%			Ω	
2	B-Constant (25-50 °C)			4250 ± 1%			K	1
3	Size			0201				

Note 1 The B constant is calculated using the zero-power resistance values measured at 25°C and 50°C

■ DIMENSIONS

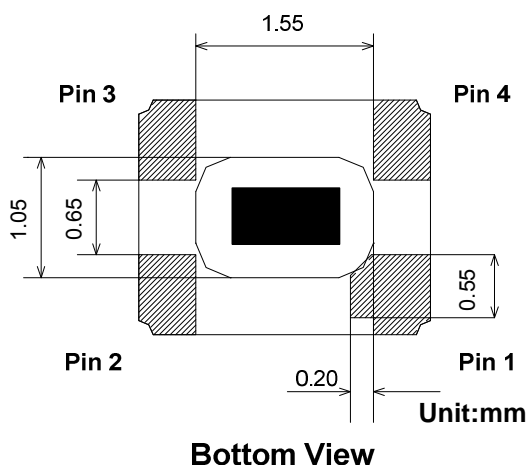
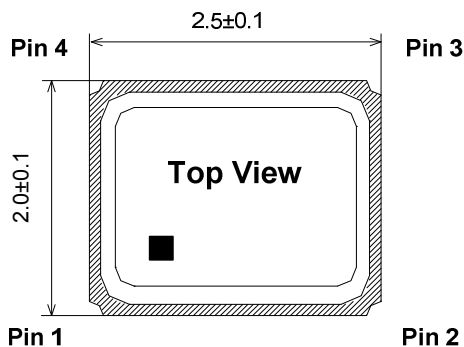

■ PIN FUNCTION

	Symbol	Function
Pin 1	XT1	XTAL Terminal 1
Pin 2	RT2	Thermistor Terminal 2
Pin 3	XT2	XTAL Terminal 2
Pin 4	RT1	Thermistor Terminal 1

Note: Pin 2 is connected to the metal lid and thermistor
Pin 4 is connected to the thermistor only

■ BLOCK DIAGRAM

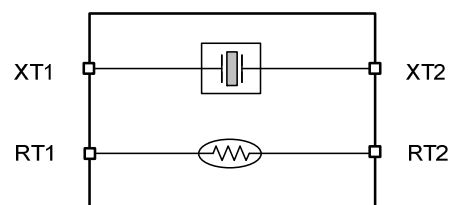

Note: RT2 shall be connected to GND is recommended

■ SUGGESTED LAYOUT

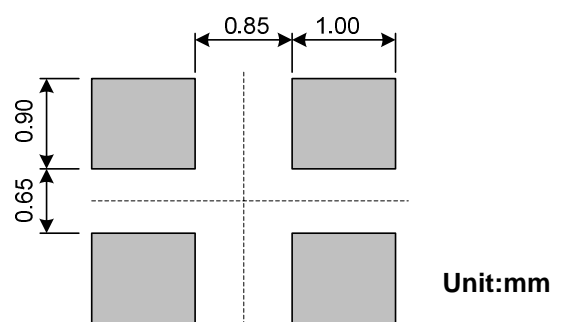

■ **SUGGESTED REFLOW PROFILE**

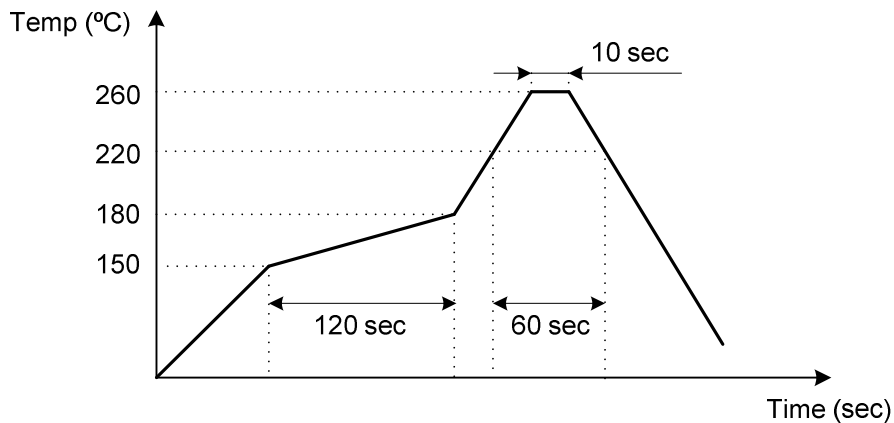

Note : Total Time: 200 sec. Max., Solder Melting Point: 220°C

■ **MARKING**

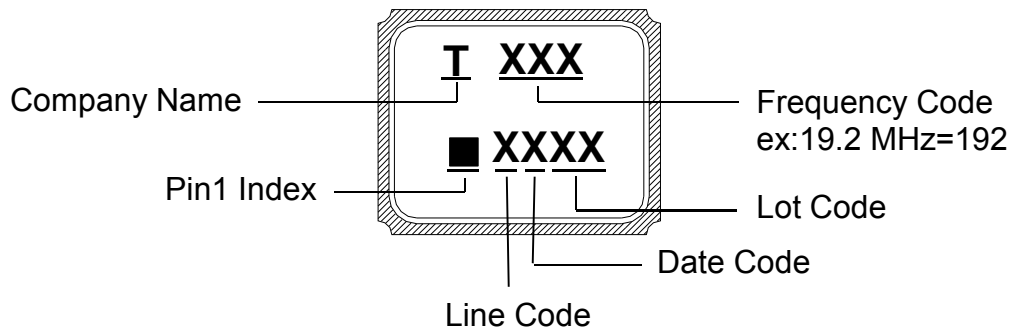

DATE CODE

MONTH				JAN	FEB	MAR	APR	MAY	JUN	JUL	AUG	SEP	OCT	NOV	DEC
YEAR															
2005	2009	2013	2017	A	B	C	D	E	F	G	H	J	K	L	M
2006	2010	2014	2018	N	P	Q	R	S	T	U	V	W	X	Y	Z
2007	2011	2015	2019	a	b	c	d	e	f	g	h	j	k	l	m
2008	2012	2016	2020	n	p	q	r	s	t	u	v	w	x	y	z

Note: This date code will be cycled every four years

■ **PACKING : (EIA-481-2)**

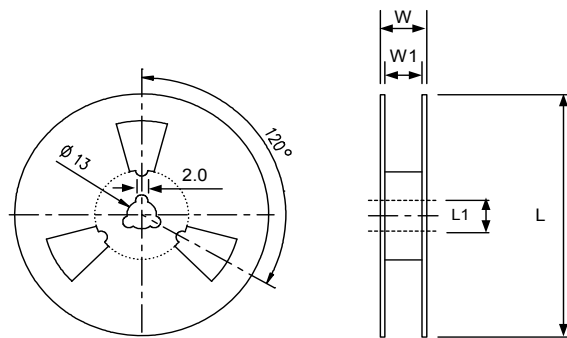
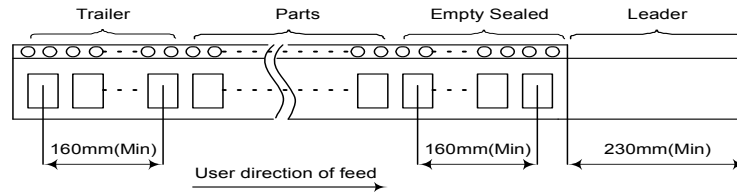
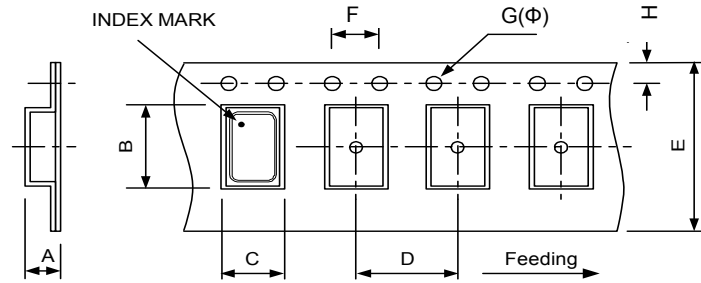

Unit: mm

DIMENSIONS (mm)	A	B	C	D	E	F	G	H	L	L1	W	W1	Standard Reel Quantity is 3,000 pcs per reel
	1.15	2.70	2.25	4.00	8.00	4.00	1.55	1.75	178	13.0	11.6	8.4	

■ **WEIGHT**

0.0135 g / piece(TYP), 40 ± 2 g /3 kpcs(regardless of tape weight)

■ **STRUCTURE ILLUSTRATION**

Crystal Enclosure Seal : Seam Welding

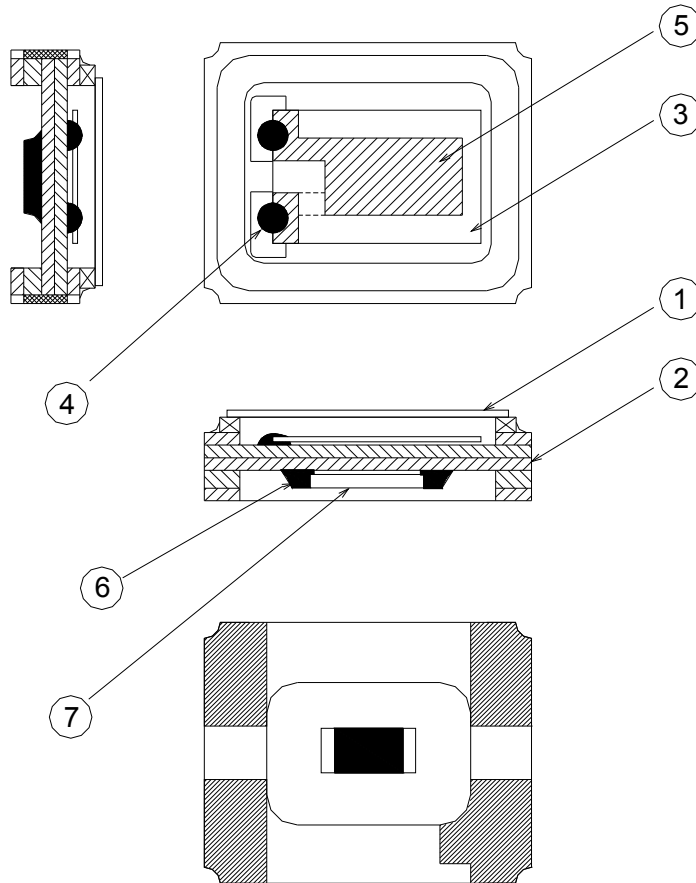

No.	COMPONENTS	MATERIALS	FINISH/SPECIFICATIONS
1	Lid	Metal (Fe+Co+Ni)	-
2	Base (Package)	Ceramic (Al ₂ O ₃) + Kovar (Fe+Co+Ni) + Ag/Cu	Alumina Ceramics
3	Crystal Blank	SiO ₂	-
4	Conductive Adhesive	Ag	Silicone Resin
5	Electrode	Noble Metal	-
6	Solder	Sn	-
7	Thermistor	Al ₂ O ₃ , Ag, Ni	-

■ RELIABILITY SPECIFICATIONS

1. Mechanical Endurance

No.	Test Item	Test Methods	Reference
1.1	Drop Test	150 cm height, 3 times on concrete floor.	JIS C6701
1.2	Mechanical Shock	Device are shocked to half sine wave (1000 G) three mutually perpendicular axes each 3 times. 0.5 msec. duration time	MIL-STD-202
1.3	Vibration	Frequency range 10 ~ 2000 Hz Amplitude 1.52 mm/20 G Sweep time 20 minutes Perpendicular axes each test time 4 Hrs (Total test time 12 Hrs)	MIL-STD-883
1.4	Gross Leak	Standard sample for automatic gross leak detector Test pressure: 2 kg / cm ²	MIL-STD-883
1.5	Fine Leak	Helium bombing 4.5 kg/ cm ² for 2 Hrs	
1.6	Solderability	Temperature 245°C ± 5°C Immersing depth 0.5 mm minimum Immersion time 5 ± 1 seconds Flux Rosin resin methyl alcohol solvent (1 : 4)	MIL-STD-883

2. Environmental Endurance

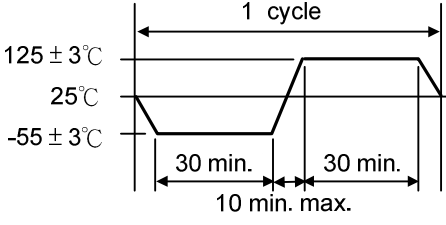
No.	Test Item	Test Methods	Reference
2.1	Resistance To Soldering Heat	Pre-heat temperature 125°C Pre-heat time 60 ~ 120 sec. Test temperature 260 ± 5°C Test time 10 ± 1 sec.	MIL-STD-202
2.2	High Temp. Storage	+ 125 °C ± 3 °C for 500 ± 12 Hrs	MIL-STD-883
2.3	Low Temp. Storage	- 40°C ± 3°C for 500 ± 12 Hrs	
2.4	Thermal Shock	Total 100 cycles of the following temperature cycle 	MIL-STD-883
2.5	High Temp & Humidity	85°C ± 3°C, RH 85% , 500 Hrs	JIS C5023

单击下面可查看定价，库存，交付和生命周期等信息

[>>TXC\(台湾晶技\)](#)