

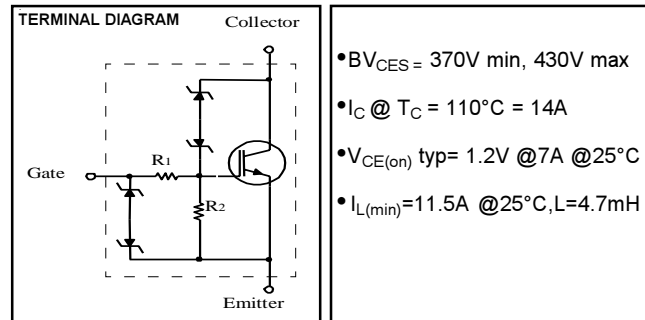
IGBT with on-chip Gate-Emitter and Gate-Collector clamps

**Features**

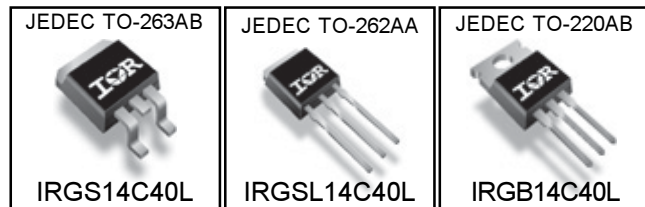
- Most Rugged in Industry
- Logic-Level Gate Drive
- > 6KV ESD Gate Protection
- Low Saturation Voltage
- High Self-clamped Inductive Switching Energy
- Lead-Free

**Description**

The advanced IGBT process family includes a MOS gated, N-channel logic level device which is intended for coil-on-plug automotive ignition applications and small-engine ignition circuits. Unique features include on-chip active voltage clamps between the Gate-Emitter and Gate-Collector which provide over voltage protection capability in ignition circuits.



- $V_{CES} = 370V \text{ min, } 430V \text{ max}$
- $I_C @ T_C = 110^\circ C = 14A$
- $V_{CE(on)} \text{ typ} = 1.2V @ 7A @ 25^\circ C$
- $I_{L(min)} = 11.5A @ 25^\circ C, L = 4.7mH$



NOTE: IRGS14C40L is available in tape and reel. Add a suffix of TRR or TRL to the part number to determine the orientation of the device in the pocket, i.e, IRGS14C40LTRR or IRGS14C40LTRL.

**Absolute Maximum Ratings**

	Parameter	Max	Unit	Condition
$V_{CES}$	Collector-to-Emitter Voltage	Clamped	V	$R_G = 1K \text{ ohm}$
$I_C @ T_C = 25^\circ C$	Continuous Collector Current	20	A	$V_{GE} = 5V$
$I_C @ T_C = 110^\circ C$	Continuous Collector Current	14	A	$V_{GE} = 5V$
$I_G$	Continuous Gate Current	1	mA	
$I_{Gp}$	Peak Gate Current	10	mA	$t_{PK} = 1ms, f = 100Hz$
$V_{GE}$	Gate-to-Emitter Voltage	Clamped	V	
$P_D @ T_C = 25^\circ C$	Maximum Power Dissipation	125	W	
$P_D @ T = 110^\circ C$	Maximum Power Dissipation	54	W	
$T_J$	Operating Junction and	- 40 to 175	$^\circ C$	
$T_{STG}$	Storage Temperature Range	- 40 to 175	$^\circ C$	
$V_{ESD}$	Electrostatic Voltage	6	KV	$C = 100pF, R = 1.5K \text{ ohm}$
$I_L$	Self-clamped Inductive Switching Current	11.5	A	$L = 4.7mH, T = 25^\circ C$

**Thermal Resistance**

	Parameter	Min	Typ	Max	Unit
$R_{\theta JC}$	Thermal Resistance, Junction-to-Case			1.2	$^\circ C/W$
$R_{\theta JA}$	Thermal Resistance, Junction-to-Ambient			40	
	(PCB Mounted, Steady State)				
$Z_{\theta JC}$	Transient Thermal Impedance, Junction-to-Case (Fig.11)				

**Off-State Electrical Characteristics @ T<sub>J</sub> = 25°C** (unless otherwise specified)

	Parameter	Min	Typ	Max	Unit	Conditions	Fig
BV <sub>CES</sub>	Collector-to-Emitter Breakdown Voltage	370	400	430	V	R <sub>G</sub> = 1K ohm, I <sub>C</sub> = 7A, V <sub>GE</sub> = 0V	
BV <sub>GES</sub>	Gate-to-Emitter Breakdown Voltage	10	12		V	I <sub>G</sub> = 2m A	
I <sub>CES</sub>	Collector-to-Emitter Leakage Current			15	μA	R <sub>G</sub> = 1K ohm, V <sub>CE</sub> = 250V	
				100	μA	R <sub>G</sub> = 1K ohm, V <sub>CE</sub> = 250V, T <sub>J</sub> = 150°C	
BV <sub>CER</sub>	Emitter-to-Collector Breakdown Voltage	24	28		V	I <sub>C</sub> = -10m A	
R <sub>1</sub>	Gate Series Resistance		75		ohm		
R <sub>2</sub>	Gate-to-Emitter Resistance	10	20	30	K ohm		

**On-State Electrical Characteristics @ T<sub>J</sub> = 25°C** (unless otherwise specified)

	Parameter	Min	Typ	Max	Unit	Conditions	Fig
V <sub>CE(on)</sub>	Collector-to-Emitter Saturation Voltage		1.2	1.40	V	I <sub>C</sub> = 7A, V <sub>GE</sub> = 4.5V	1
			1.35	1.55		I <sub>C</sub> = 10A, V <sub>GE</sub> = 4.5V	
			1.35	1.55		I <sub>C</sub> = 10A, V <sub>GE</sub> = 4.5V, T <sub>C</sub> = -40°C	4
			1.5	1.7		I <sub>C</sub> = 14A, V <sub>GE</sub> = 5.0V, T <sub>C</sub> = -40°C	
			1.55	1.75		I <sub>C</sub> = 14A, V <sub>GE</sub> = 5.0V	
			1.6	1.8		I <sub>C</sub> = 14A, V <sub>GE</sub> = 5.0V, T <sub>C</sub> = 150°C	
V <sub>GE(th)</sub>	Gate Threshold Voltage	1.3	1.8	2.2	V	V <sub>CE</sub> = V <sub>GE</sub> , I <sub>C</sub> = 1 m A, T <sub>C</sub> = 25°C	3, 5
		0.75		1.8		V <sub>CE</sub> = V <sub>GE</sub> , I <sub>C</sub> = 1 m A, T <sub>C</sub> = 150°C	
g <sub>fs</sub>	Transconductance	10	15	19	S	V <sub>CE</sub> = 25V, I <sub>C</sub> = 10A, T <sub>C</sub> = 25°C	
I <sub>C</sub>	Collector Current	20			A	V <sub>CE</sub> = 10V, V <sub>GE</sub> = 4.5V	

**Switching Characteristics @ T<sub>J</sub> = 25°C** (unless otherwise specified)

	Parameter	Min	Typ	Max	Unit	Conditions	Fig
Q <sub>g</sub>	Total Gate charge		27		nC	I <sub>C</sub> = 10A, V <sub>CE</sub> = 12V, V <sub>GE</sub> = 5V	7
Q <sub>ge</sub>	Gate - Emitter Charge		2.5			I <sub>C</sub> = 10A, V <sub>CE</sub> = 12V, V <sub>GE</sub> = 5V	15
Q <sub>gc</sub>	Gate - Collector Charge		10			I <sub>C</sub> = 10A, V <sub>CE</sub> = 12V, V <sub>GE</sub> = 5V	
t <sub>d(on)</sub>	Turn - on delay time	0.6	0.9	1.35	μs	V <sub>GE</sub> = 5V, R <sub>G</sub> = 1K ohm, L = 1mH, V <sub>CE</sub> = 14V	12
t <sub>r</sub>	Rise time	1.6	2.8	4		V <sub>GE</sub> = 5V, R <sub>G</sub> = 1K ohm, L = 1mH, V <sub>CE</sub> = 14V	14
t <sub>d(off)</sub>	Turn - off delay time	3.7	6	8.3		V <sub>GE</sub> = 5V, R <sub>G</sub> = 1K ohm, L = 1mH, V <sub>CE</sub> = 300V	
C <sub>ies</sub>	Input Capacitance		550	825	pF	V <sub>GE</sub> = 0V, V <sub>CE</sub> = 25V, f = 1M H z	6
C <sub>oes</sub>	Output Capacitance		100	150		V <sub>GE</sub> = 0V, V <sub>CE</sub> = 25V, f = 1M H z	
C <sub>res</sub>	Reverse Transfer Capacitance		12	18		V <sub>GE</sub> = 0V, V <sub>CE</sub> = 25V, f = 1M H z	
I <sub>L</sub>	Self-Clamped Inductive Switching Current	25			A	L = 0.7m H, T <sub>C</sub> = 25°C	9
		15.5				L = 2.2m H, T <sub>C</sub> = 25°C	
		11.5				L = 4.7m H, T <sub>C</sub> = 25°C	10
		16.5				L = 1.5m H, T <sub>C</sub> = 150°C	
		7.5				L = 4.7m H, T <sub>C</sub> = 150°C	
		6				L = 8.7m H, T <sub>C</sub> = 150°C	
t <sub>sc</sub>	Short Circuit Withstand Time		120		μs	T <sub>J</sub> = 150°C, V <sub>CC</sub> = 16V, L = 10μH R <sub>G</sub> = 1K ohm, V <sub>GE</sub> = 5V	14

Fig.1 - Typ. Output Characteristics  
 $T_J=25^\circ\text{C}$

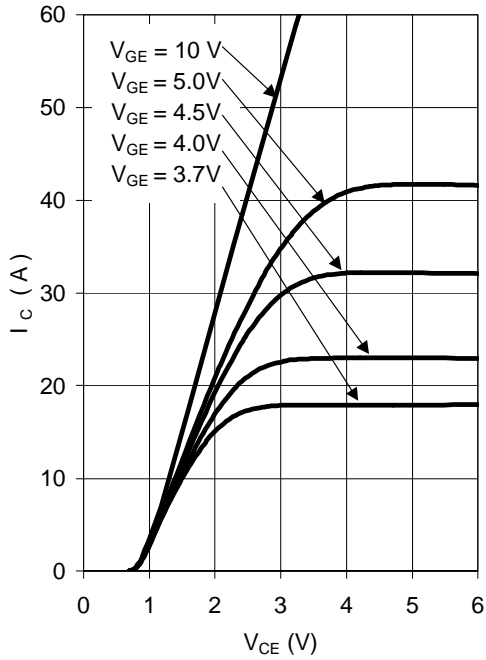


Fig.2 - Typ. Output Characteristics  
 $T_J=125^\circ\text{C}$

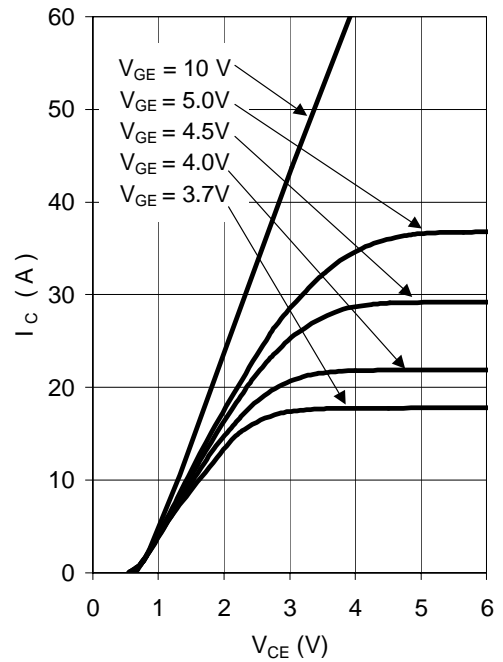


Fig.3 - Transfer Characteristics  
 $V_{CE}=20\text{V}; t_p=20\mu\text{s}$

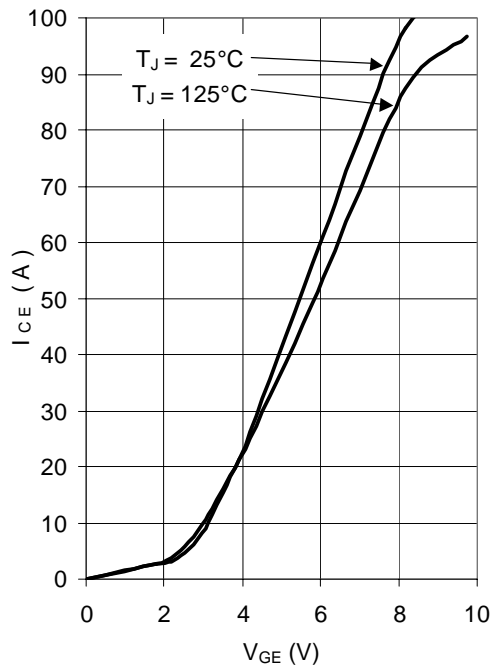
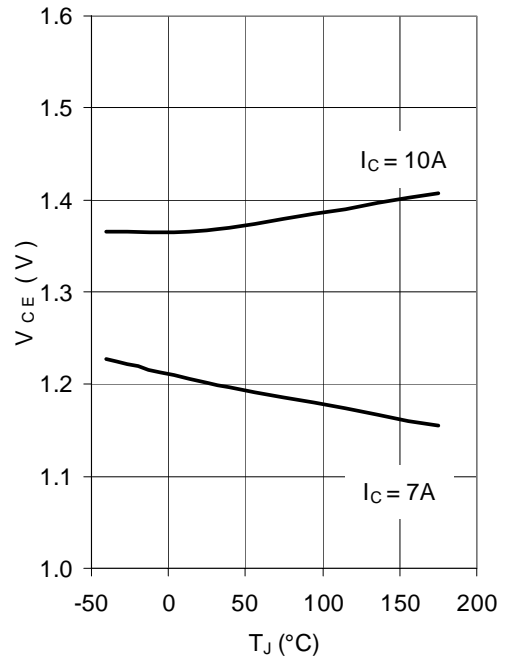


Fig.4 - Typical  $V_{CE}$  vs  $T_J$   
 $V_{GE}=4.5\text{V}$



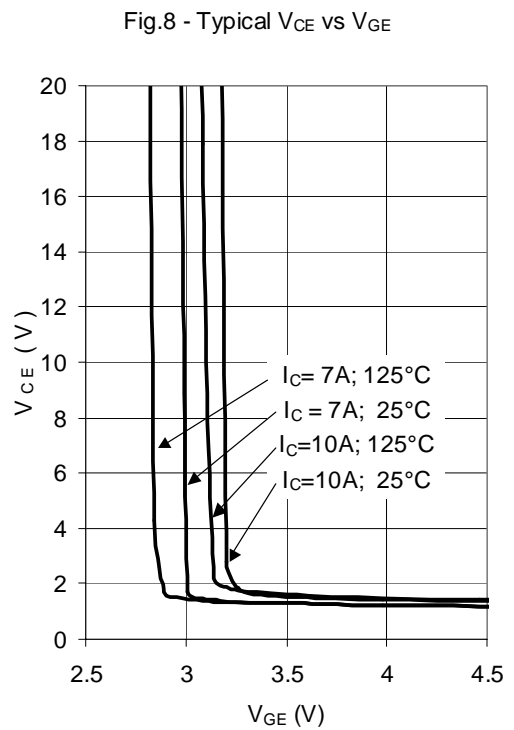
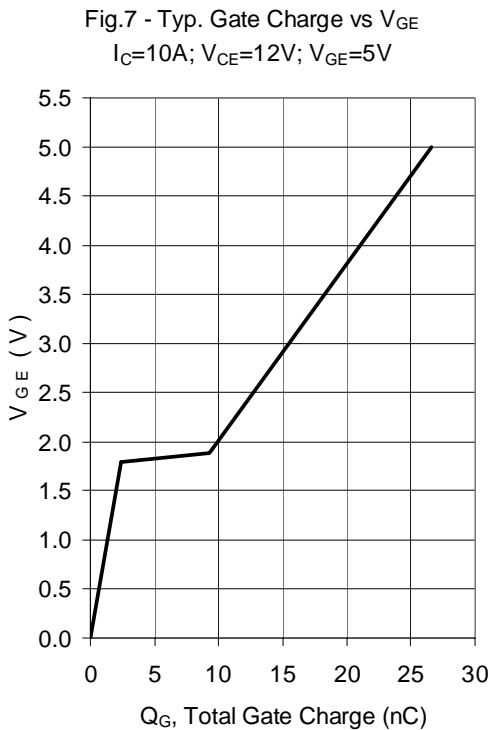
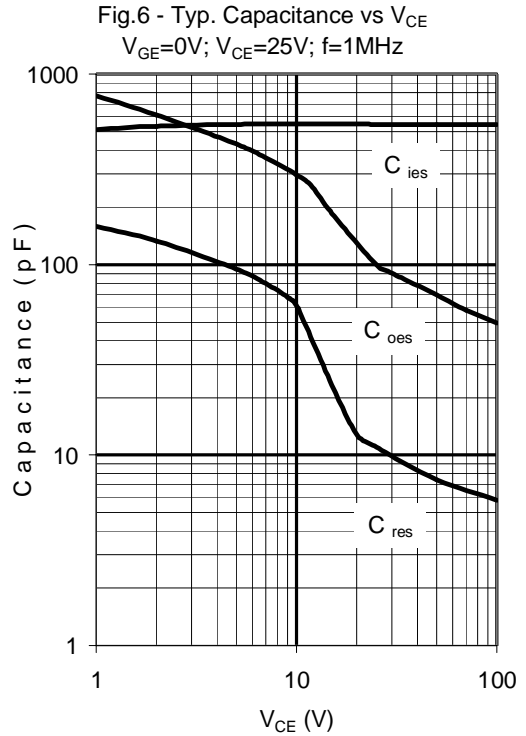
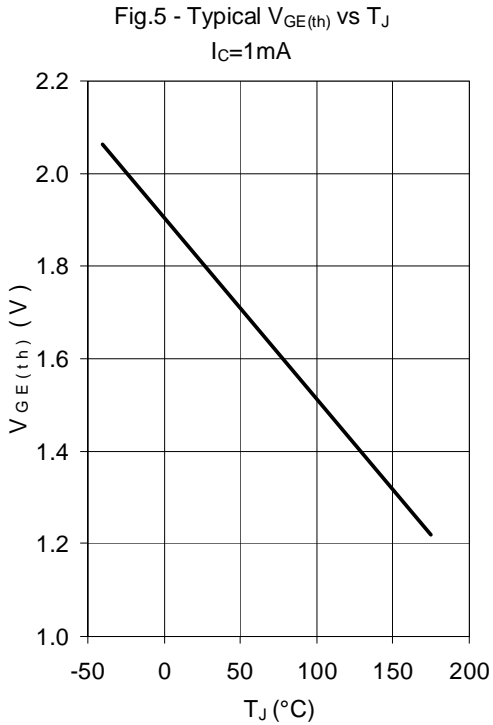


Fig.9 - Self-clamp Avalanche Current vs Inductance @ 25°C

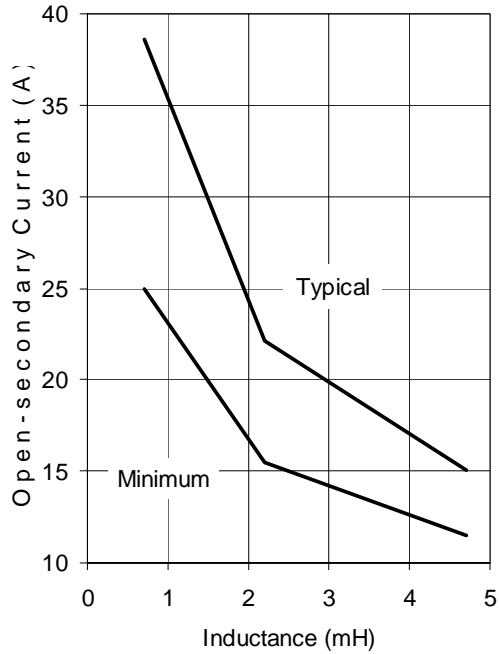


Fig.10 - Self-clamp Avalanche Current vs Inductance @ 150°C

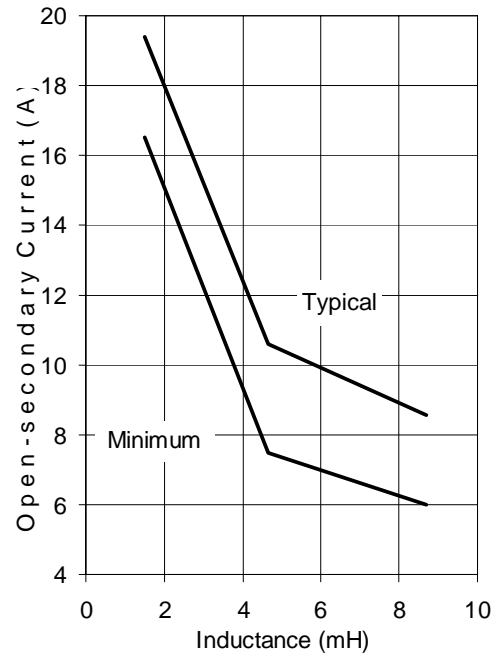


Fig.11 - Transient Thermal Impedance, Junction-to-Case

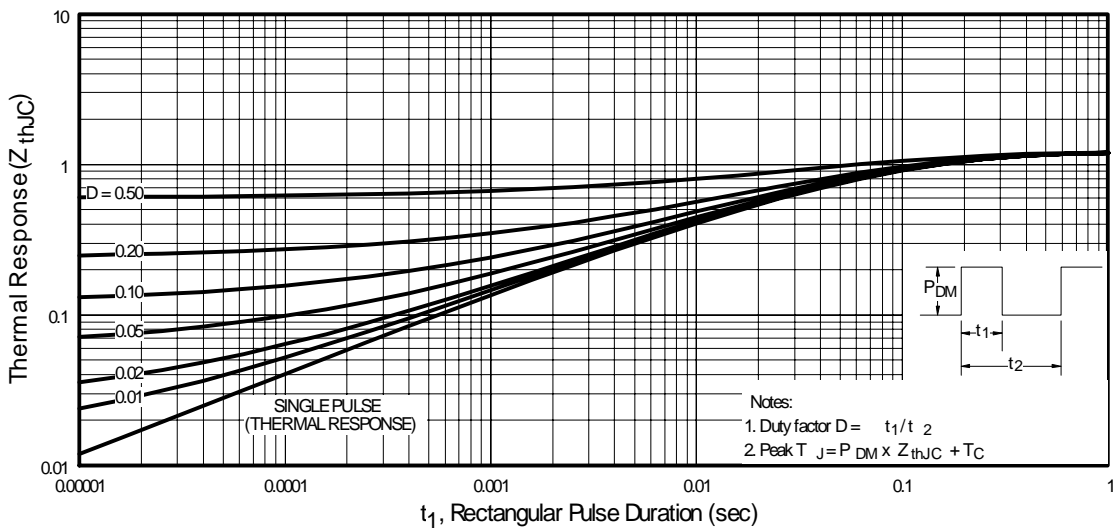


Fig.12 - Switching Waveform for Time Measurement

$V_{GE} = 5V$ ;  $R_G = 1K\Omega$ ;  $L = 1mH$ ;  $V_{CE} = 14V$ ; used circuit in Fig.14

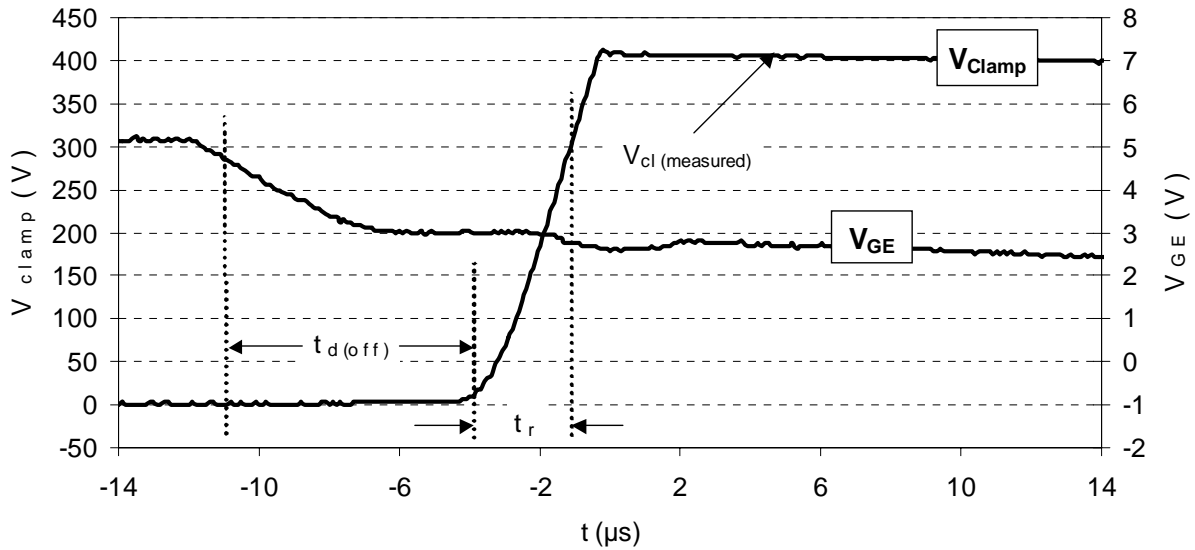
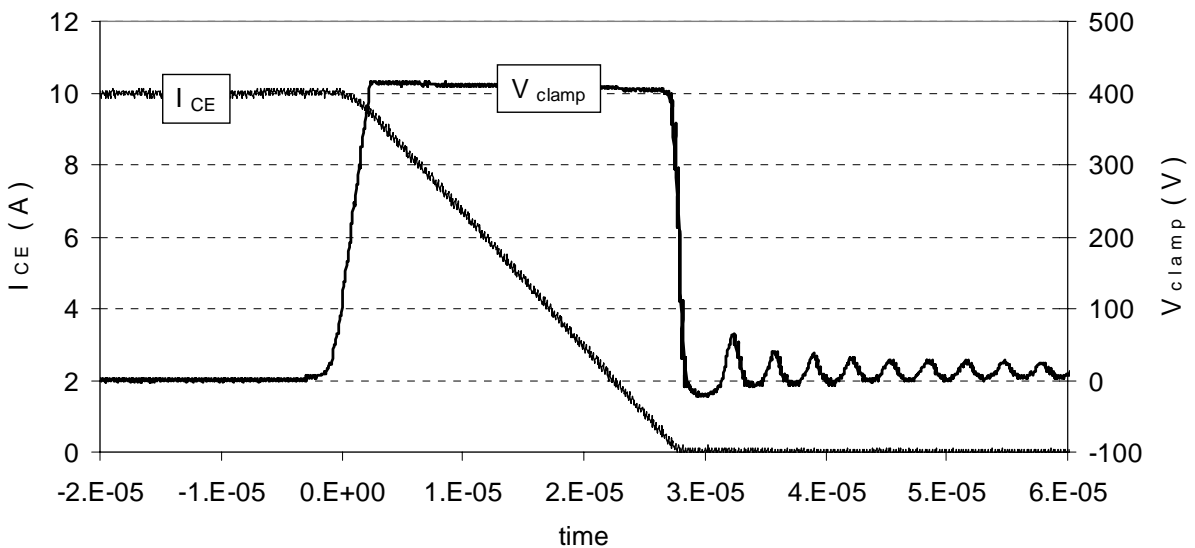
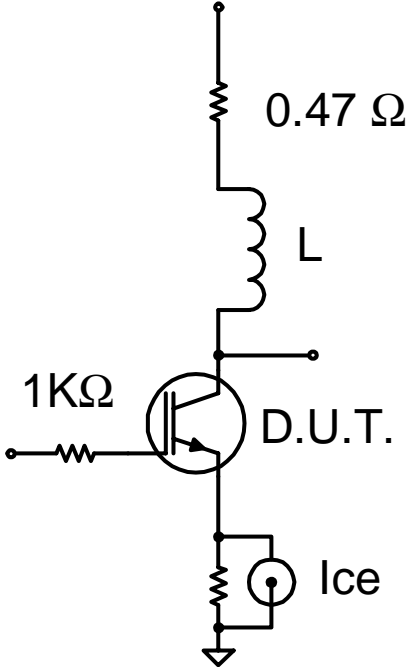


Fig.13 - Self-clamped Inductive Switching Waveform

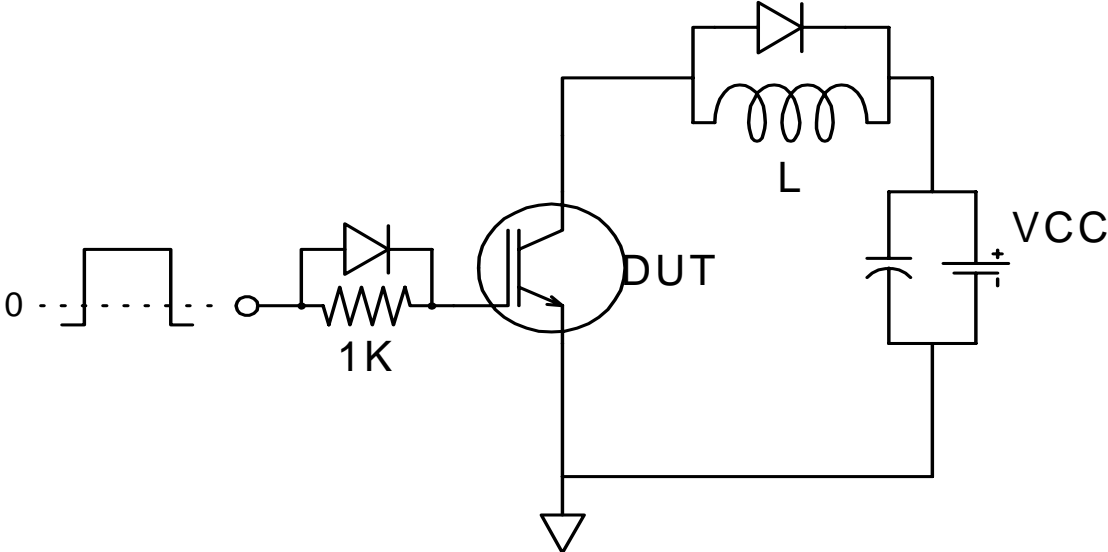
$L = 4.7mH$ ;  $T_C = 25^\circ C$ ; used circuit in Fig.14



**Fig.14 - Test Circuit**

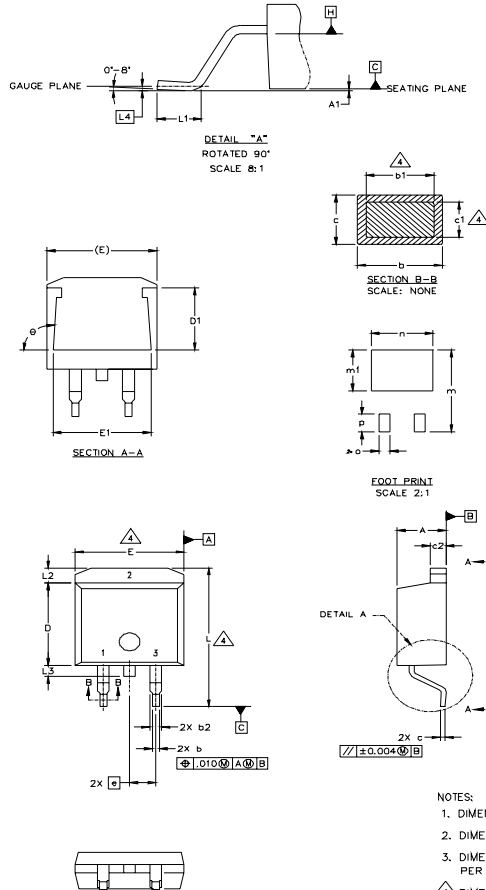


**Fig.15 - Gate Charge Circuit**



### D<sup>2</sup>Pak Package Outline

Dimensions are shown in millimeters (inches)



SYMBOL	DIMENSIONS				NOTES
	MILLIMETERS		INCHES		
	MIN.	MAX.	MIN.	MAX.	
A	4.06	4.83	.160	.190	4
A1	0.127	0.127	.005	.005	
b	0.51	0.99	.020	.039	
b1	0.51	0.89	.020	.035	
b2	1.14	1.40	.045	.055	4
c	0.43	0.63	.017	.025	
c1	0.38	0.74	.015	.029	3
c2	1.14	1.40	.045	.055	
D	8.51	9.65	.335	.380	3
D1	5.33		.210		
E	9.65	10.67	.380	.420	3
E1	6.22		.245		
e	2.54	BSC	.100	BSC	
L	14.61	15.88	.575	.625	
L1	1.78	2.79	.070	.110	
L2		1.65		.065	
L3	1.27	1.78	.050	.070	
L4	0.25	BSC	.010	BSC	
m	17.78		.700		
m1	8.89		.350		
n	11.43		.450		
o	2.08		.082		
p	3.81		.150		
θ	90°	93°	90°	93°	

LEAD ASSIGNMENTS

HEXFET	IGBTs, CoPACK	DIODES
1.- GATE	1.- GATE	1.- ANODE *
2.- DRAIN	2.- COLLECTOR	2.- CATHODE
3.- SOURCE	3.- EMITTER	3.- ANODE

\* PART DEPENDENT.

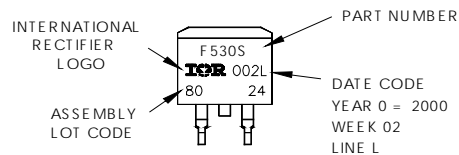
NOTES:

1. DIMENSIONING AND TOLERANCING PER ASME Y14.5M-1994
2. DIMENSIONS ARE SHOWN IN MILLIMETERS [INCHES].
3. DIMENSION D & E DO NOT INCLUDE MOLD FLASH. MOLD FLASH SHALL NOT EXCEED 0.127 [.005"] PER SIDE. THESE DIMENSIONS ARE MEASURED AT THE OUTMOST EXTREMES OF THE PLASTIC BODY.
4. DIMENSION b1 AND c1 APPLY TO BASE METAL ONLY.
5. CONTROLLING DIMENSION: INCH.

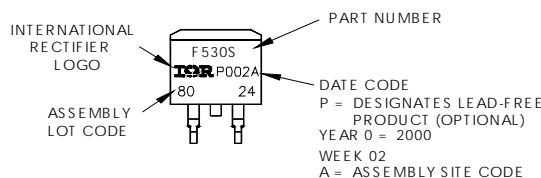
### D<sup>2</sup>Pak Part Marking Information (Lead-Free)

EXAMPLE: THIS IS AN IRF530S WITH LOT CODE 8024 ASSEMBLED ON WW 02, 2000 IN THE ASSEMBLY LINE "L"

Note: "P" in assembly line position indicates "Lead-Free"



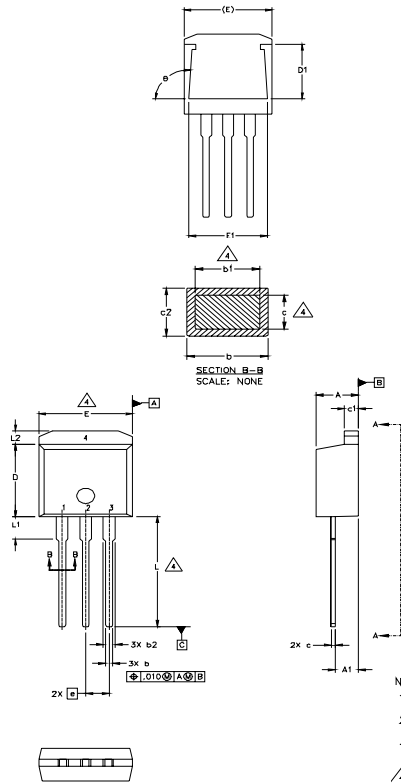
**OR**





### TO-262 Package Outline

Dimensions are shown in millimeters (inches)



SYMBOL	DIMENSIONS				NOTES
	MILLIMETERS		INCHES		
	MIN.	MAX.	MIN.	MAX.	
A	4.06	4.83	.160	.190	
A1	2.03	2.92	.080	.115	
b	0.51	0.99	.020	.039	
b1	0.51	0.89	.020	.035	4
b2	1.14	1.40	.045	.055	
c	0.38	0.63	.015	.025	4
c1	1.14	1.40	.045	.055	
c2	0.43	.063	.017	.029	
D	8.51	9.65	.335	.380	3
D1	5.33		.210		
E	9.65	10.67	.380	.420	3
E1	6.22		.245		
e	2.54	BSC	.100	BSC	
L	13.46	14.09	.530	.555	
L1	3.56	3.71	.140	.146	
L2		1.65		.065	

#### LEAD ASSIGNMENTS

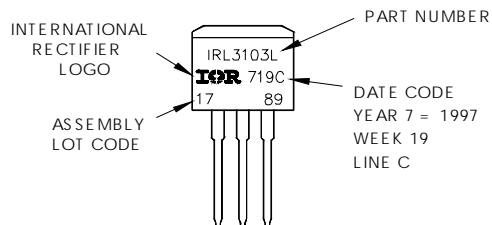
HEXFET	IGBT
1.- GATE	1 - GATE
2.- DRAIN	2 - COLLECTOR
3.- SOURCE	3 - EMITTER
4.- DRAIN	

- NOTES:
1. DIMENSIONING AND TOLERANCING PER ASME Y14.5M-1994
  2. DIMENSIONS ARE SHOWN IN MILLIMETERS [INCHES].
  3. DIMENSION D & E DO NOT INCLUDE MOLD FLASH. MOLD FLASH SHALL NOT EXCEED 0.127 [ .005" ] PER SIDE. THESE DIMENSIONS ARE MEASURED AT THE OUTMOST EXTREMES OF THE PLASTIC BODY.
  4. DIMENSION b1 AND c1 APPLY TO BASE METAL ONLY.
  5. CONTROLLING DIMENSION: INCH.

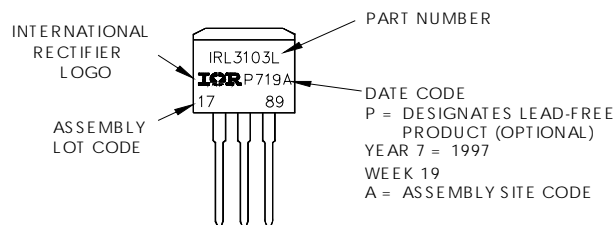
### TO-262 Part Marking Information

EXAMPLE: THIS IS AN IRL3103L  
LOT CODE 1789  
ASSEMBLED ON WW 19, 1997  
IN THE ASSEMBLY LINE "C"

Note: "P" in assembly line position indicates "Lead-Free"

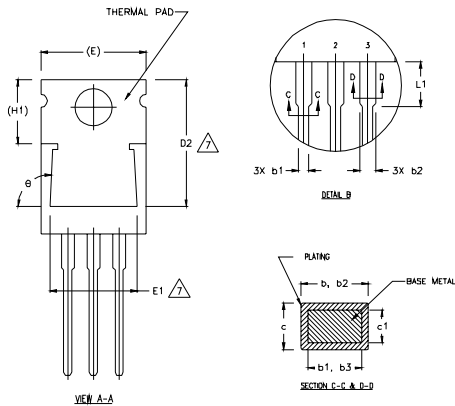
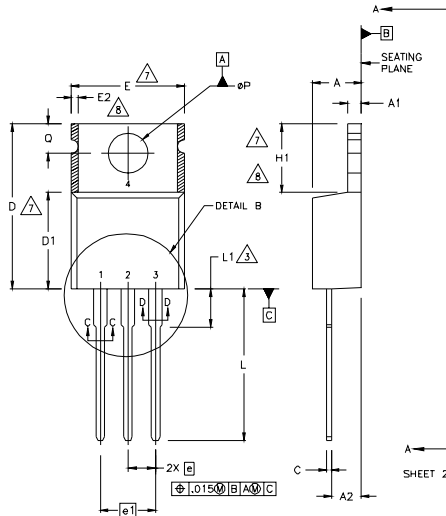


**OR**



### TO-220AB Package Outline

Dimensions are shown in millimeters (inches)



NOTES:

- 1 DIMENSIONING AND TOLERANCING PER ASME Y14.5 M- 1994.
- 2 DIMENSIONS ARE SHOWN IN INCHES [MILLIMETERS].
- 3 LEAD DIMENSION AND FINISH UNCONTROLLED IN L1.
- 4 DIMENSION D & E DO NOT INCLUDE MOLD FLASH. MOLD FLASH SHALL NOT EXCEED .005" (0.127) PER SIDE. THESE DIMENSIONS ARE MEASURED AT THE OUTERMOST EXTREMES OF THE PLASTIC BODY.
- 5 DIMENSION b1 & c1 APPLY TO BASE METAL ONLY.
- 6 CONTROLLING DIMENSION ; INCHES.
- 7 THERMAL PAD CONTOUR OPTIONAL WITHIN DIMENSIONS E,H1,D2 & E1
- 8 DIMENSION E2 X H1 DEFINE A ZONE WHERE STAMPING AND SINGULATION IRREGULARITIES ARE ALLOWED.

LEAD ASSIGNMENTS

HEXFEET

- 1.- GATE
- 2.- DRAN
- 3.- SOURCE

IGBTs, CoPACK

- 1.- GATE
- 2.- COLLECTOR
- 3.- EMITTER

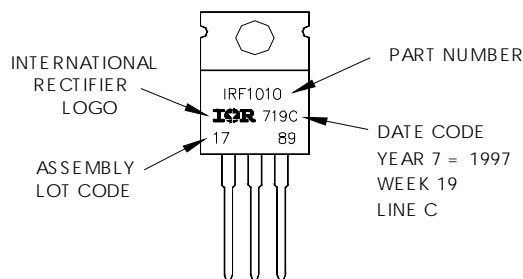
DIODES

- 1.- ANODE/OPEN
- 2.- CATHODE
- 3.- ANODE

SYMBOL	DIMENSIONS				NOTES
	MILLIMETERS		INCHES		
	MIN.	MAX.	MIN.	MAX.	
A	3.56	4.82	.140	.190	
A1	0.51	1.40	.020	.055	
A2	2.04	2.92	.080	.115	
b	0.38	1.01	.015	.040	
b1	0.38	0.96	.015	.038	5
b2	1.15	1.77	.045	.070	
b3	1.15	1.73	.045	.068	
c	0.36	0.61	.014	.024	
c1	0.36	0.56	.014	.022	5
D	14.22	16.51	.560	.650	4
D1	8.38	9.02	.330	.355	
D2	12.19	12.88	.480	.507	7
E	9.66	10.66	.380	.420	4,7
E1	8.38	8.89	.330	.350	7
e	2.54 BSC		.100 BSC		
e1	5.08		.200 BSC		
H1	5.85	6.55	.230	.270	7,8
L	12.70	14.73	.500	.580	
L1	-	6.35	-	.250	3
øP	3.54	4.08	.139	.161	
Q	2.54	3.42	.100	.135	
ø	90°-93°		90°-93°		

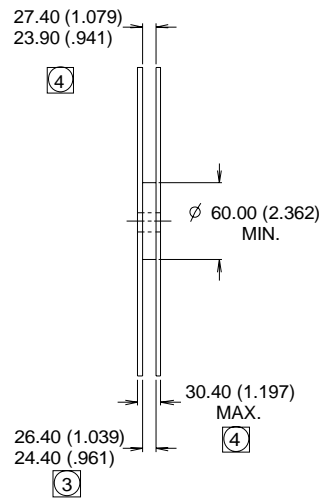
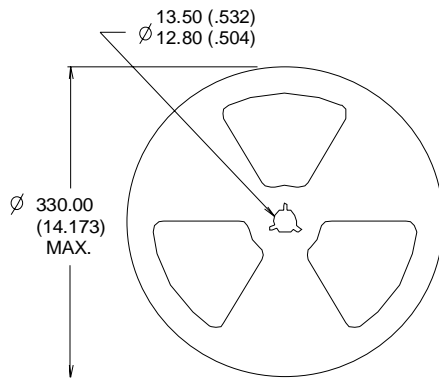
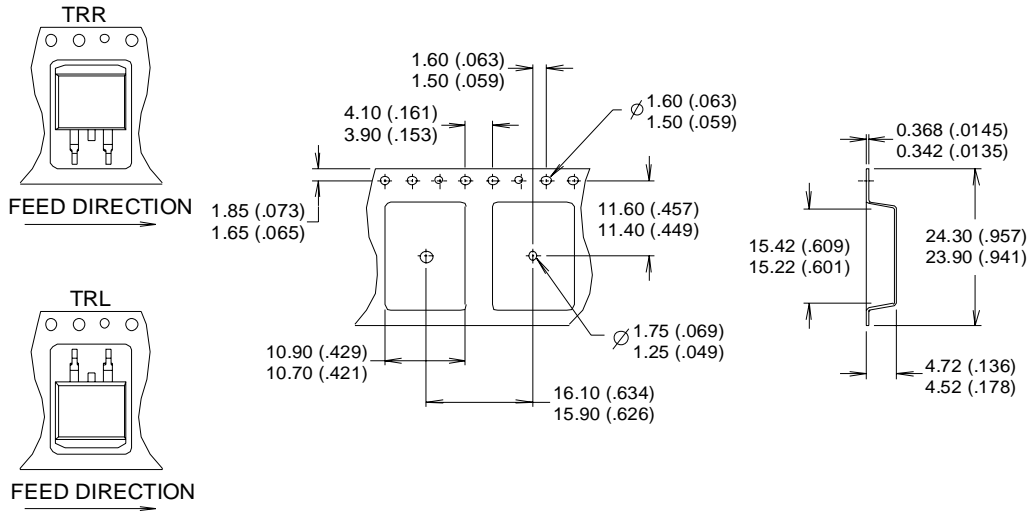
### TO-220AB Part Marking Information

EXAMPLE: THIS IS AN IRF1010  
LOT CODE 1789  
ASSEMBLED ON WW 19, 1997  
IN THE ASSEMBLY LINE "C"  
**Note:** "P" in assembly line position indicates "Lead-Free"



D<sup>2</sup>Pak Tape & Reel Information

Dimensions are shown in millimeters (inches)



- NOTES :
1. COMFORMS TO EIA-418.
  2. CONTROLLING DIMENSION: MILLIMETER.
  - ③ DIMENSION MEASURED @ HUB.
  - ④ INCLUDES FLANGE DISTORTION @ OUTER EDGE.

Data and specifications subject to change without notice.

Note: For the most current drawings please refer to the IR website at:  
<http://www.irf.com/package/>

单击下面可查看定价，库存，交付和生命周期等信息

[>>Infineon Technologies\(英飞凌\)](#)