



Approval Sheet

Customer Information

Customer :			
Part Name :			
Part No. :			
Model No. :			
	Company	Purchase	R&D

Vendor Information

Name:	SFI Electronics Technology INC.
Part Name	Chip Surge Protection Device (CSPD) Series
Part No.	SEA(ESD Automotive) Device – SFI0603EA240-HSP
Lot No.	

SFI Electronics Technology INC.

ADDRESS : No.6, Lane 340, Shan-Ying Road , Guishan,Tao Yuan Taiwan

TEL: 886-3-3506998 FAX: 886-3-3507689 E-mail: sfi@sfi.com.tw

Quality Control	Document Control	Business Issue	
 <p>ISO 9001:2008 ISO TS16949:2009 ISO 14001:2004</p>	REV : B	Prepared	Check
	 <p>2012.6.05 Issue Date</p>		

Part No. :	SFI0603EA240-HSP	Document No.	AS-RD0603ME139-LF	REV.	B
http://www.sfi.com.tw E-mail : sfi@sfi.com.tw TEL:886-3-3506998 FAX :886-3-3507689 - 1 -					



PART NO. SFI0603EA240-HSP

1.1 Technology Data	Symbol	Value	Unit
Maximum allowable continuous DC voltage	V_{DC}	16	V
Breakdown voltage measured	V_V	28~38	V
Maximum clamping voltage	V_{CLAMP} <	57	V
Maximum ESD protection	V_{ESD}	25	KV

1.2 Reference Data	Symbol	Value	Unit
Typical capacitance value measured at 1M Hz	C	10	pF
Capacitance range		±30	%
Response time	T_{rise} <	1	ns
Non-linear coefficient	α >	20	
Leakage current (Before ESD Test)	I_v <	1.5	uA
Leakage current (After ESD Test)	I_{vA} <	4	uA
Operation ambient temperature		-55~+125	°C
Storage temperature		-55~+150	°C

1.3 Other Data	Symbol	Value	Unit
Body		Nano Special Ceramic	
End termination		Ag/Ni/Sn	
Packaging		Reel	
Complies with Standard		ISO 10605 AEC-Q200 Rev.C	
Complies with ISO7637-2 Standard		Pulse 1, 2a, 2b, 3a and 3b	
Complies with RoHs Standard		Yes	
Lead Content	<	1000	ppm
Marking		None	

Notes :

- * 1 The breakdown voltage was measured at 1 mA current.
- * 2 The clamping voltage was measured at standard current, 0603(1A).
- * 3 The leakage current was tested at working voltage.
- * 4 The components shall be employed within 1 year, in the nitrogen condition.

Part No. :	SFI0603EA240-HSP	Document No.	AS-RD0603ME139-LF	REV.	B
http://www.sfi.com.tw E-mail : sfi@sfi.com.tw TEL:886-3-3506998 FAX :886-3-3507689 - 2 -					

1.4 Features of SEA Device

1. RoHS compliant
2. SMD type Body size 0603
3. Meet ISO 10605 and IEC61000-4-2
4. Meet ISO7637-2 Standard, Pulse 1, 2a, 2b, 3a and 3b
5. Large withstanding ESD voltage capability : 25KV
6. Qualified based on AEC-Q200
7. Bidirectional and symmetrical V/I characteristics
8. Excellent low leakage current <math><2\mu A</math>
9. Operating temperature range : -55 ~ +125 °C
10. Multi-Layers construction provides higher power dissipation

Equivalent Circuit

- ☆L **Body Inductance**
- ☆C **Device Capacitance**
- ☆VR **Voltage Variable Resistor**
- ☆R **Insulation Resistor**
- ☆Diode **Voltage clamped**
- ☆PTC **For low leakage current**

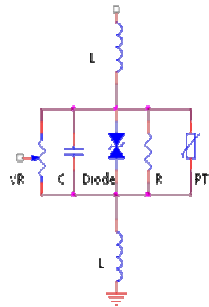

2.Size

Model	0603
Length(L)	1.60±0.15
Width(W)	0.80±0.10
Thickness(T)	0.90 max
Termination(a)	0.3±0.1

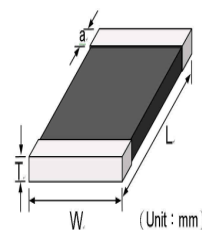

Part No. :	SFI0603EA240-HSP	Document No.	AS-RD0603ME139-LF	REV.	B
http://www.sfi.com.tw E-mail : sfi@sfi.com.tw TEL:886-3-3506998 FAX :886-3-3507689 - 3 -					

3. ESD Wave Form

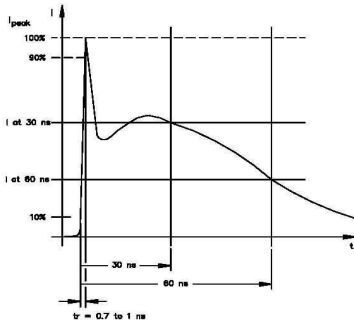

ISO 10605 Standards

SEVERITY LEVEL	From inside vehicle	From outside vehicle
I	±4 KV	±4 KV
II	±8 KV	±8 KV
III	±14 KV	±15 KV
IV	±15 KV	±25 KV

4. ISO7637-2 Pulse 1, 2a, 2b, 3a and 3b Wave Form and Test Parameters

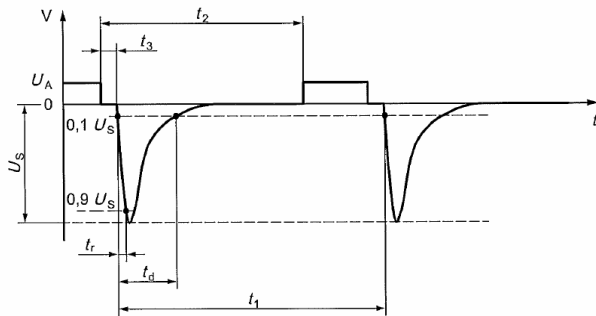

Parameters for test pulse 1

Parameters	12 System
Pulse Voltage (Us)	-75~-150V
Pulse Period (t1)	≥ 0.5s
Rise Time (tr)	1μs
Output Resistance (Ri)	10Ω
Pulse Width (td)	2ms

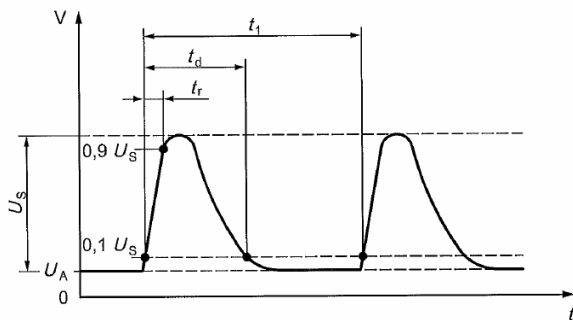

Parameters for test pulse 2A

Parameters	12 System
Pulse Voltage (Us)	37~112V
Pulse Period (t1)	0.2~5s
Rise Time (tr)	1μs
Output Resistance (Ri)	2Ω
Pulse Width (td)	0.05ms

Part No. :	SFI0603EA240-HSP	Document No.	AS-RD0603ME139-LF	REV.	B
http://www.sfi.com.tw E-mail : sfi@sfi.com.tw TEL:886-3-3506998 FAX :886-3-3507689 - 4 -					

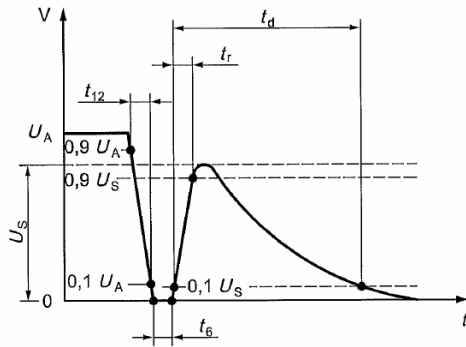

Parameters for test pulse 2B

Parameters	12 System
Pulse Voltage (Us)	10V
t _f	1±0.5ms
t ₆	1±0.5ms
Rise Time (tr)	1±0.5ms
Pulse Width (td)	0.2~2s
Output Resistance (Ri)	0~0.05Ω

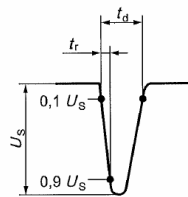
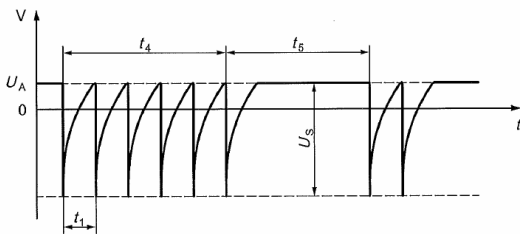

Parameters for test pulse 3A

Parameters	12 System
Pulse Voltage (Us)	-112~-220V
Pulse Period (t1)	100μs
Rise Time (tr)	5±1.5ns
Output Resistance (Ri)	50Ω
Pulse Width (td)	150±45ns
Burst Interval (t5)	90ms
Burst Duration (t4)	10ms

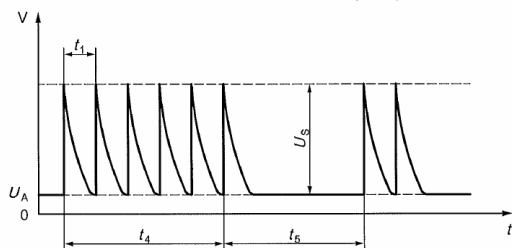
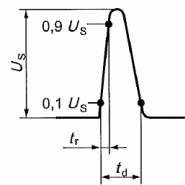

Parameters for test pulse 3B

Parameters	12 System
Pulse Voltage (Us)	75~150V
Pulse Period (t1)	100μs
Rise Time (tr)	5±1.5ns
Output Resistance (Ri)	50Ω
Pulse Width (td)	150±45ns
Burst Interval (t5)	90ms
Burst Duration (t4)	10ms



5. Environmental Reliability Test

Test	Standard	Requirement	Specifications
High Temperature Exposure (Storage)	MIL-STD-202 Method 108	Test temp. : 150 ±3°C Duration: 1000 h Unpowered	1.No visible damage 2. $ \Delta V_{1mA}/V_{1mA} \leq 10\%$ Measurement at 24±2 hours after test conclusion.
Temperature Cycling	JESD22 Method JA-104	Lower test temp. : -40±3°C Upper test temp. : 125±3°C Number of cycles : 1000	
Moisture Resistance	MIL-STD-202 Method 106	Lower test temperature: 25±3°C Upper test temperature: 65±3°C Rel. humidity of air:90%~98% (during cooling phase:80%~98%) Duration of 1 cycle: 24 h Number of cycles: 10 · Unpowered	
Biased Humidity	MIL-STD-202 Method 103	Test temp. : 85±3°C Rel. humidity of air : 85~90% Duration: 1000 h Bias at Working Voltage Vdc.	
Operational Life	MIL-STD-202 Method 108	Test temp.: 125±3°C Duration: 1000 h Bias at Working Voltage Vdc.	
Mechanical Shock	MIL-STD-202 Method 213	Test Condition F Peak value : 1500g's Half sine Waveform	
Vibration	MIL-STD-202 Method 204	Acceleration : 5 g's Sweep time: 20 min Frequency range: 10 to 2000 Hz 3×12 cycles	
Thermal Shock	MIL-STD-202 Method 107	Lower test temp. : -55±3°C Upper test temp. : 125 ±3°C Dwell time : 15 minutes. Air-Air. Number of cycles : 300	

Part No. :	SFI0603EA240-HSP	Document No.	AS-RD0603ME139-LF	REV.	B
http://www.sfi.com.tw E-mail : sfi@sfi.com.tw TEL:886-3-3506998 FAX :886-3-3507689 -6-					

6. Soldering Recommendations

6.1 Recommended solder pad layout

(Unit : mm)

	A	B	C	D
0603	0.8~1.2	2.2~2.8	0.6~1.0	0.9~1.5

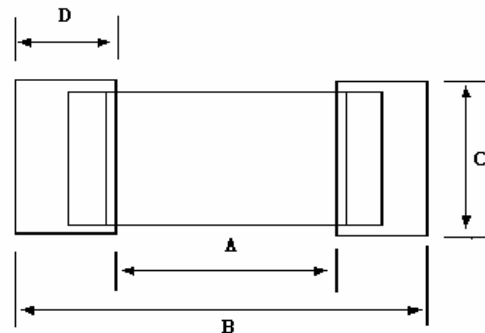

6.2 The SIR test of the solder paste shall be done (Based on JIS-Z-3284)

6.3 Steel plate and foot distance printing

Foot distance printing (mm)	Steel Plate thickness (mm)
> 0.65mm	0.18mm
0.65mm~0.5mm	0.15mm
0.50mm~0.40mm	0.12mm
<=0.40 mm	0.10mm

6.4 The IR reflow and temperature of Soldering for Pb Free

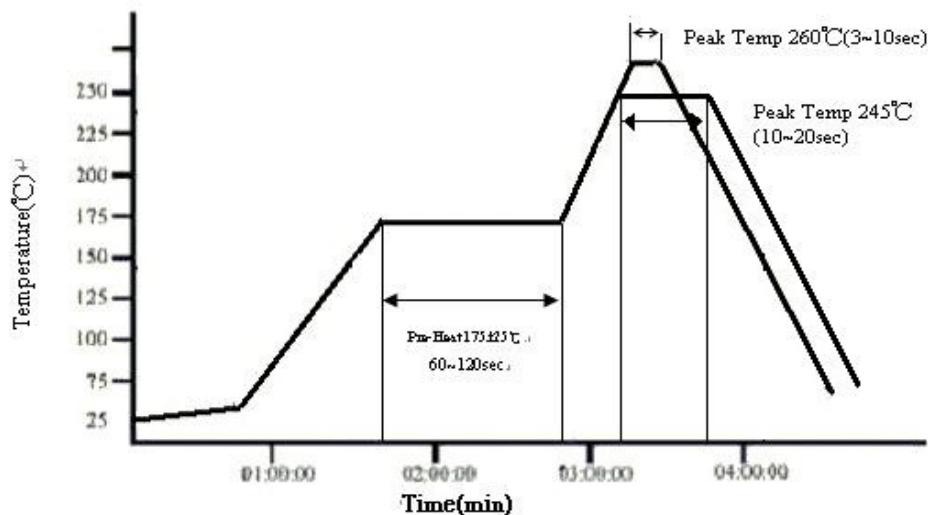

☆ IR reflow Pb Free Process suggestion profile

- (1) The solder recommend is Sn96.5/Ag 3.5 of 120 to 150 μ m
- (2) Ramp-up rate (217°C to Peak) + 3°C/second max
- (3) Temp. maintain at 175 +/-25°C 180 seconds max
- (4) Temp. maintain above 217 °C 60-150 seconds
- (5) Peak temperature range 245°C +20°C/ -10 °C time within 5 °C of actually peak temperature (tp) 10~20 seconds

Part No. :	SFI0603EA240-HSP	Document No.	AS-RD0603ME139-LF	REV.	B
http://www.sfi.com.tw E-mail : sfi@sfi.com.tw TEL:886-3-3506998 FAX :886-3-3507689 - 7 -					



(6) Ramp down rate +6 °C/second max.

※Perform adequate test in advance as the reflow temperature profile will vary according to the conditions of the manufacturing process, and the specification of the reflow furnace.

6.5 Resistance to soldering heat-High Temperature Resistance:260°C,10sec-3times.

6.6 Hand Soldering

In hand soldering of the Varistors. Large temperature gradient between preheated the Varistors and the tip of soldering iron may cause electrical failures and mechanical damages such as crackings or breakings of the devices. The soldering shall be carefully controlled and carried out so that the temperature gradient is kept minimum with following recommended conditions for hand soldering.

6.6.1 Recommended Soldering Condition 1

- (1) Solder :
0.12~0.18mm Thread solder (Sn96.5:Ag3.5) with soldering flux in the core.
Rosin-based and non-activated flux is recommended.
- (2) Preheating
The Varistors shall be preheated so that Temperature Gradient between the devices and the tip of soldering iron is 150°C or below.
- (3) Soldering Iron
Rated Power of 20w max with 3mm soldering tip in diameter.
Temperature of soldering iron tip 380°C max,3-5sec (The required amount of solder shall be melted in advance on the soldering tip.)
- (4) Cooling
After soldering. The Varistors shall be cooled gradually at room ambient temperature.

6.6.2 Recommended Soldering Condition 2 (Without preheating)

- (1) Solder iron tip shall not directly touch to ceramic dielectrics.
- (2) Solder iron tip shall be fully preheated before soldering while soldering iron tip to the external electrode of Varistors.

6.7 Post Soldering Cleaning

6.7.1 Residues of corrosive soldering fluxes on the PC board after cleaning may greatly have influences on the electrical characteristic and the reliability (such as humidity resistance)of the Varistors which have been mounted on the board. It shall be confirmed that the characteristic and the reliability of the devices are not affected by the applied cleaning conditions.

6.7.2. When an ultrasonic cleaning is applied to the mounted Varistors on PC Boards. Following conditions are recommended for preventing failures or damages of the devices due to the large vibration energy and the resonance caused by the ultrasonic waves.

- (1) Frequency 29MHz max
- (2) Radiated Power 20w/lithr max
- (3) Period 5minuets max

Part No. :	SFI0603EA240-HSP	Document No.	AS-RD0603ME139-LF	REV.	B
http://www.sfi.com.tw E-mail : sfi@sfi.com.tw TEL:886-3-3506998 FAX :886-3-3507689					- 8 -

7. Packaging Specification

- 7.1 Carrier tape and transparent cover tape should be heat-sealed to carry the products, and the reel should be used to reel the carrier tape.
- 7.2 The adhesion of the heat-sealed cover tape shall be $40 \pm 20 / - 15$ grams.
- 7.3 Both the head and the end portion of the taping shall be empty for reel package and SMT auto-pickup machine. And a normal paper tape shall be connected in the head of taping for the operator to handle.

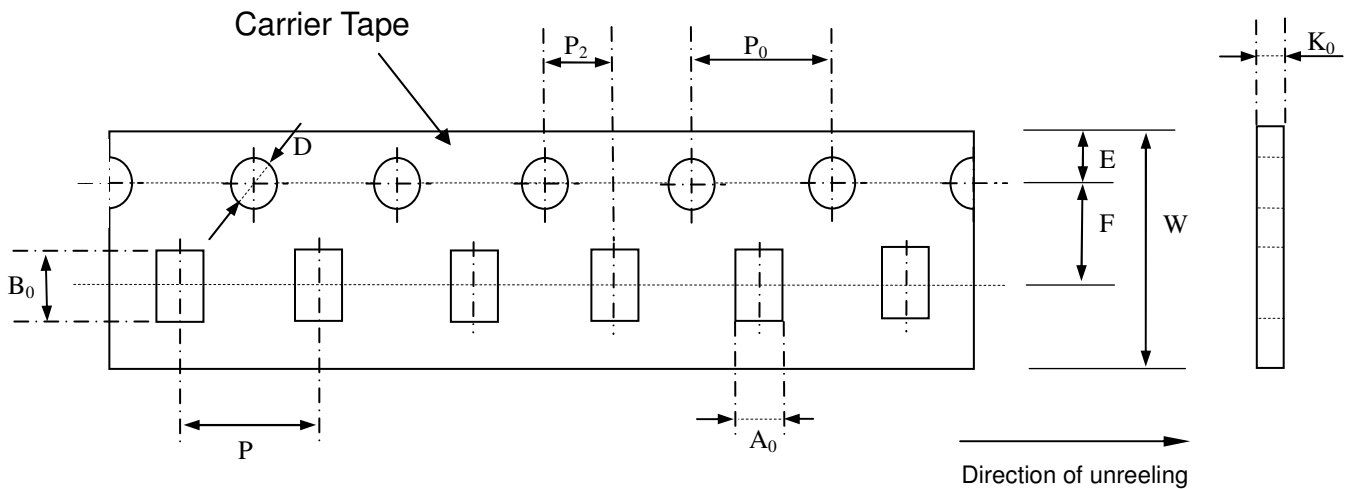

Symbol	A_0 ± 0.05	B_0 ± 0.05	K_0 ± 0.05	D $+0.10$ -0.05	P ± 0.10	P_2 ± 0.10	P_0 ± 0.10	W ± 0.10	E ± 0.10	F ± 0.05
0603	1.10	1.90	0.95	1.56	4.00	2.00	4.00	8.00	1.75	3.50

Part No. :	SFI0603EA240-HSP	Document No.	AS-RD0603ME139-LF	REV.	B
http://www.sfi.com.tw E-mail : sfi@sfi.com.tw TEL:886-3-3506998 FAX :886-3-3507689 - 9 -					



8.Reel Dimension

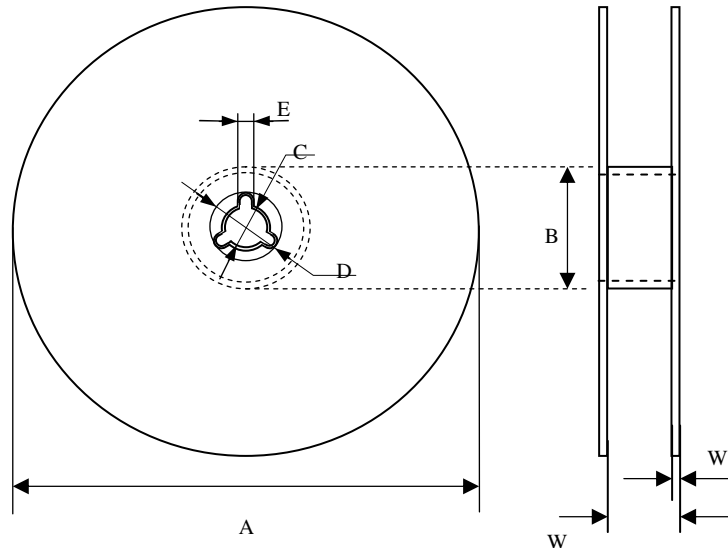

Symbol	A	B	C	D	E	W	W ₁
0603	178.0±1.0	60.0±0.5	13.0±0.2	21.0±0.2	2.0±0.5	9.0±0.50	1.5±0.15

9.Standard Packaging

Size	0603
Pcs	4000

Part No. :	SFI0603EA240-HSP	Document No.	AS-RD0603ME139-LF	REV.	B
http://www.sfi.com.tw E-mail : sfi@sfi.com.tw TEL:886-3-3506998 FAX :886-3-3507689 - 10					

单击下面可查看定价，库存，交付和生命周期等信息

[>>SFI\(台湾立昌\)](#)