

April 26,2023

All Rights by Senodia Technologies (Shaoxing)Co.,Ltd

**Senodia**  
Turn to smarter life

# SH3001 DATASHEET

## 6-Axis IMU

Package:14-Pin LGA

Dimension:3.0×2.5×1.0mm<sup>3</sup>

Document Revision: 1.7

Senodia Technologies ( Shaoxing ) Co. Ltd.  
No.28,Lane555 Huanqiao Road,  
Pudong New Area,Shanghai.

# 1 Basic Descriptions

## 1.1 SH3001

SH3001 is a highly integrated and low power 6-Axis inertial measurement unit (IMU) that combines both acceleration and angular rate measurement in one chip.

The device integrates:

- 16-bit digital 3-axis accelerometer with  $\pm 2g$ ,  $\pm 4g$ ,  $\pm 8g$  and  $\pm 16g$  range
- 16-bit digital 3-axis gyroscope with  $\pm 125dps$ ,  $\pm 250dps$ ,  $\pm 500dps$ ,  $\pm 1000dps$ ,  $\pm 2000dps$  range

## 1.2 Features and Benefits

- Compact and small size, 14-Pin LGA package with  $3.0 \times 2.5 \text{ mm}^2$  footprint
- Wide operating temperature range:  $-40^\circ\text{C} - 85^\circ\text{C}$
- Wide power supply range: VDD 1.71V-3.60V and independent VDDIO 1.71V-3.60V
- User-programmable low-pass filter for both accelerometer and gyroscope
- User-programmable interrupts
- On-chip digital output temperature sensor
- Configurable secondary digital interface for AUX devices
- 1kB on-chip FIFO for accelerometer, gyroscope, temperature and AUX sensor data
- 2 independent programmable I/O pins for interrupt
- RoHS compliant, halogen and lead free

## 1.3 Applications

- Mobile phones
- Smart watches, wristbands and fitness trackers
- Motion-enabled game and application framework
- Motion-based game controllers
- Augmented and virtual reality glasses and controllers
- Attitude monitoring
- Smart toys

# Contents

|          |   |           |
|----------|---|-----------|
| <b>1</b> | <b>Basic Descriptions</b>   | <b>1</b>  |
| 1.1      | SH3001 . . . . .  | 1         |
| 1.2      | Features and Benefits . . . . .   | 1         |
| 1.3      | Applications . . . . .  | 1         |
| <b>2</b> | <b>Functional Diagram</b>   | <b>7</b>  |
| <b>3</b> | <b>SH3001 Specifications</b>  | <b>8</b>  |
| 3.1      | Gyroscope Specifications . . . . .                                      | 8         |
| 3.2      | Accelerometer Specifications . . . . .                                  | 9         |
| 3.3      | Temperature Sensor Specifications . . . . .                             | 10        |
| 3.4      | Power Modes . . . . .   | 10        |
| 3.5      | Electrical Characteristics . . . . .                                    | 11        |
| 3.6      | Digital Interface Characteristics . . . . .                             | 11        |
| 3.6.1    | Serial Peripheral Interface (SPI) . . . . .                             | 11        |
| 3.6.2    | Inter-Integrated Circuit (I <sup>2</sup> C) . . . . .                   | 12        |
| 3.7      | Absolute Maximum Ratings . . . . .                                      | 13        |
| <b>4</b> | <b>Pin Description</b>  | <b>14</b> |
| 4.1      | Pin Out View . . . . .  | 14        |
| 4.2      | Pin Descriptions . . . . .  | 14        |
| <b>5</b> | <b>Functional Explanations</b>  | <b>15</b> |
| 5.1      | Six-Axis MEMS Sensor With 16-bit ADCs and Signal Conditioning . . . . . | 15        |
| 5.2      | Digital Output Temperature Sensor . . . . .                             | 15        |
| 5.3      | Auxiliary I <sup>2</sup> C Serial Interface . . . . .                   | 15        |
| 5.4      | FIFO . . . . .  | 15        |
| 5.5      | Interrupt . . . . .   | 16        |
| 5.5.1    | General Features . . . . .  | 16        |
| 5.5.2    | Inactivity Interrupt . . . . .  | 17        |
| 5.5.3    | Activity Interrupt . . . . .  | 18        |
| 5.5.4    | Double & Single Tap Interrupt . . . . .                                 | 18        |
| 5.5.5    | Tap Interrupt . . . . .   | 18        |
| 5.5.6    | Flat Interrupt . . . . .  | 19        |

|          |  |           |
|----------|--|-----------|
| 5.5.7    | Orientation Interrupt . . . . .  | 19        |
| 5.5.8    | FIFO Watermark Interrupt . . . . .   | 20        |
| 5.5.9    | Gyroscope Data Ready Interrupt . . . . .                                     | 21        |
| 5.5.10   | Accelerometer Data Ready Interrupt . . . . .                                 | 21        |
| 5.5.11   | Free-fall Interrupt . . . . .  | 21        |
| 5.5.12   | Low-G Interrupt . . . . .  | 21        |
| 5.5.13   | High-G Interrupt . . . . .   | 21        |
| <b>6</b> | <b>Digital Interfaces</b>  | <b>22</b> |
| 6.1      | General Description . . . . .  | 22        |
| 6.2      | Primary Interfaces . . . . .   | 22        |
| 6.2.1    | Primary Interface I <sup>2</sup> C/SPI Protocol Selection . . . . .          | 22        |
| 6.2.2    | Primary SPI Interface . . . . .  | 22        |
| 6.2.3    | Primary I <sup>2</sup> C Interface . . . . .                                 | 24        |
| <b>7</b> | <b>Register Descriptions</b>   | <b>26</b> |
| 7.1      | Register Descriptions . . . . .  | 26        |
| 7.1.1    | Register 0x00 - 0x05: Accelerometer Data . . . . .                           | 26        |
| 7.1.2    | Register 0x06 - 0x0B: Gyroscope Data . . . . .                               | 27        |
| 7.1.3    | Register 0x0C - 0x0D: Temperature Data . . . . .                             | 28        |
| 7.1.4    | Register 0x0F: Chip ID . . . . .   | 28        |
| 7.1.5    | Register 0x10 - 0x15: Interrupt Status . . . . .                             | 28        |
| 7.1.6    | Register 0x16 - 0x17: FIFO Status . . . . .                                  | 30        |
| 7.1.7    | Register 0x18: FIFO Data . . . . .   | 30        |
| 7.1.8    | Register 0x20 - 0x21 & 0xD5: Temperature Sensor Configuration . . . . .      | 30        |
| 7.1.9    | Register 0x22 - 0x26: Accelerometer Configuration . . . . .                  | 31        |
| 7.1.10   | Register 0x28 - 0x2B & 0x8F & 0x9F & 0xAF: Gyroscope Configuration . . . . . | 32        |
| 7.1.11   | Register 0x32: SPI Configuration . . . . .                                   | 34        |
| 7.1.12   | Register 0x35 - 0x39: FIFO Configuration . . . . .                           | 34        |
| 7.1.13   | Register 0x3A - 0x3B: Master I <sup>2</sup> C Configuration . . . . .        | 35        |
| 7.1.14   | Register 0x3C - 0x3D: Master I <sup>2</sup> C Command . . . . .              | 36        |
| 7.1.15   | Register 0x3E: Master I <sup>2</sup> C Write Data . . . . .                  | 36        |
| 7.1.16   | Register 0x3F: Master I <sup>2</sup> C Read Out Data . . . . .               | 36        |
| 7.1.17   | Register 0x40 - 0x41: Interrupt Enable . . . . .                             | 37        |

|           |  |           |
|-----------|--|-----------|
| 7.1.18    | Register 0x44: Interrupt Configuration . . . . .   | 37        |
| 7.1.19    | Register 0x45: Interrupt Count Limit . . . . .   | 38        |
| 7.1.20    | Register 0x46 - 0x4D: Orientation Interrupt Configuration . . . . .  | 38        |
| 7.1.21    | Register 0x4E: Flat Interrupt Configuration . . . . .  | 40        |
| 7.1.22    | Register 0x4F - 0x50 & 0x55 - 0x58 & 0x7B - 0x7E: Activity & Inactivity<br>Interrupt Configuration . . . . . | 40        |
| 7.1.23    | Register 0x50 - 0x54: Tap Interrupt Configuration . . . . .  | 42        |
| 7.1.24    | Register 0x59 - 0x5D: High-G & Low-G Interrupt Configuration . . . . .                                       | 43        |
| 7.1.25    | Register 0x5E - 0x5F: Free Fall Interrupt Configuration . . . . .  | 44        |
| 7.1.26    | Register 0x79 - 0x7A: Interrupt Pin Mapping . . . . .  | 45        |
| 7.1.27    | Register 0x7F: SPI Register Access . . . . .   | 46        |
| 7.1.28    | Register 0xFD: Auxiliary I <sup>2</sup> C Configuration . . . . .  | 46        |
| <b>8</b>  | <b>Application Hints</b>   | <b>47</b> |
| 8.1       | Orientation of Axes . . . . .  | 47        |
| 8.2       | Typical Application Circuits . . . . .   | 48        |
| 8.3       | Package Information . . . . .  | 51        |
| 8.3.1     | Device Outline Dimensions . . . . .  | 51        |
| 8.3.2     | Package Laser Mark . . . . .   | 52        |
| 8.3.3     | Packaging Direction . . . . .  | 52        |
| 8.3.4     | Packaging Label . . . . .  | 52        |
| 8.3.5     | Packaging of Product . . . . .   | 53        |
| 8.4       | Soldering Guidelines . . . . .   | 53        |
| 8.5       | Storage Condition . . . . .  | 54        |
| <b>9</b>  | <b>Reliability</b>   | <b>55</b> |
| 9.1       | Reliability Standard . . . . .   | 55        |
| <b>10</b> | <b>Environment Compliant</b>   | <b>56</b> |
| <b>11</b> | <b>Disclaimer</b>  | <b>57</b> |
| <b>12</b> | <b>Revision History</b>  | <b>58</b> |

## List of Figures

|           |   |    |
|-----------|---|----|
| Figure 1  | Functional diagram of the device . . . . .  | 7  |
| Figure 2  | SPI timing diagram . . . . .  | 12 |
| Figure 3  | I <sup>2</sup> C timing diagram . . . . .   | 12 |
| Figure 4  | The pin out view of SH3001 . . . . .  | 14 |
| Figure 5  | Connection diagram through the auxiliary I <sup>2</sup> C bus . . . . .                             | 22 |
| Figure 6  | 4-wire SPI write sequence . . . . .   | 23 |
| Figure 7  | 4-wire SPI read sequence . . . . .  | 23 |
| Figure 8  | 3-wire SPI read and write sequence . . . . .  | 23 |
| Figure 9  | 4-wire SPI multiple read sequence . . . . .   | 24 |
| Figure 10 | 4-wire SPI multiple write sequence . . . . .  | 24 |
| Figure 11 | I <sup>2</sup> C single byte write . . . . .  | 25 |
| Figure 12 | I <sup>2</sup> C single byte read . . . . .   | 25 |
| Figure 13 | I <sup>2</sup> C multiple bytes write . . . . .   | 25 |
| Figure 14 | I <sup>2</sup> C multiple bytes read . . . . .  | 25 |
| Figure 15 | Orientation of axes sensitivity and polarity of rotation . . . . .                                  | 47 |
| Figure 16 | Reference application circuitry using only primary I <sup>2</sup> C interface . . . . .             | 48 |
| Figure 17 | Reference application circuitry using primary and secondary I <sup>2</sup> C interface . . . . .    | 48 |
| Figure 18 | Reference application circuitry using SPI 3-wire interface . . . . .                                | 49 |
| Figure 19 | Reference application circuitry using SPI 3-wire and secondary I <sup>2</sup> C interface . . . . . | 49 |
| Figure 20 | Reference application circuitry using SPI 4-wire interface . . . . .                                | 50 |
| Figure 21 | Reference application circuitry using SPI 4-wire and secondary I <sup>2</sup> C interface . . . . . | 50 |
| Figure 22 | Top & bottom view of the device . . . . .   | 51 |
| Figure 23 | Side view of the device . . . . .   | 51 |
| Figure 24 | Package laser mark . . . . .  | 52 |
| Figure 25 | Packaging direction . . . . .   | 52 |
| Figure 26 | Packaging label example . . . . .   | 52 |
| Figure 27 | Packaging of the product . . . . .  | 53 |
| Figure 28 | Recommended soldering reflow condition . . . . .  | 53 |

## List of Tables

|          |  |    |
|----------|--|----|
| Table 1  | Gyroscope specifications . . . . .   | 8  |
| Table 2  | Accelerometer specifications . . . . .   | 9  |
| Table 3  | Temperature sensor specifications . . . . .  | 10 |
| Table 4  | Power modes . . . . .  | 10 |
| Table 5  | Electrical characteristics . . . . .   | 11 |
| Table 6  | SPI interface characteristics . . . . .  | 11 |
| Table 7  | I <sup>2</sup> C interface characteristics . . . . .                               | 12 |
| Table 8  | Absolute maximum ratings . . . . .   | 13 |
| Table 9  | Pin descriptions . . . . .   | 14 |
| Table 10 | Interrupts supported by SH3001 . . . . .   | 17 |
| Table 11 | Meaning of the orient mode register in symmetrical mode . . . . .                  | 20 |
| Table 12 | Meaning of the orient mode register in high-asymmetrical mode . . . . .            | 20 |
| Table 13 | Meaning of the orient mode register in low-asymmetrical mode . . . . .             | 20 |
| Table 14 | Gyroscope digital LPF cut-off frequency configuration (unit: <i>Hz</i> ) . . . . . | 33 |
| Table 15 | Dimension references (unit: <i>mm</i> ) . . . . .                                  | 51 |
| Table 16 | Recommended soldering reflow condition . . . . .                                   | 54 |

## 2 Functional Diagram

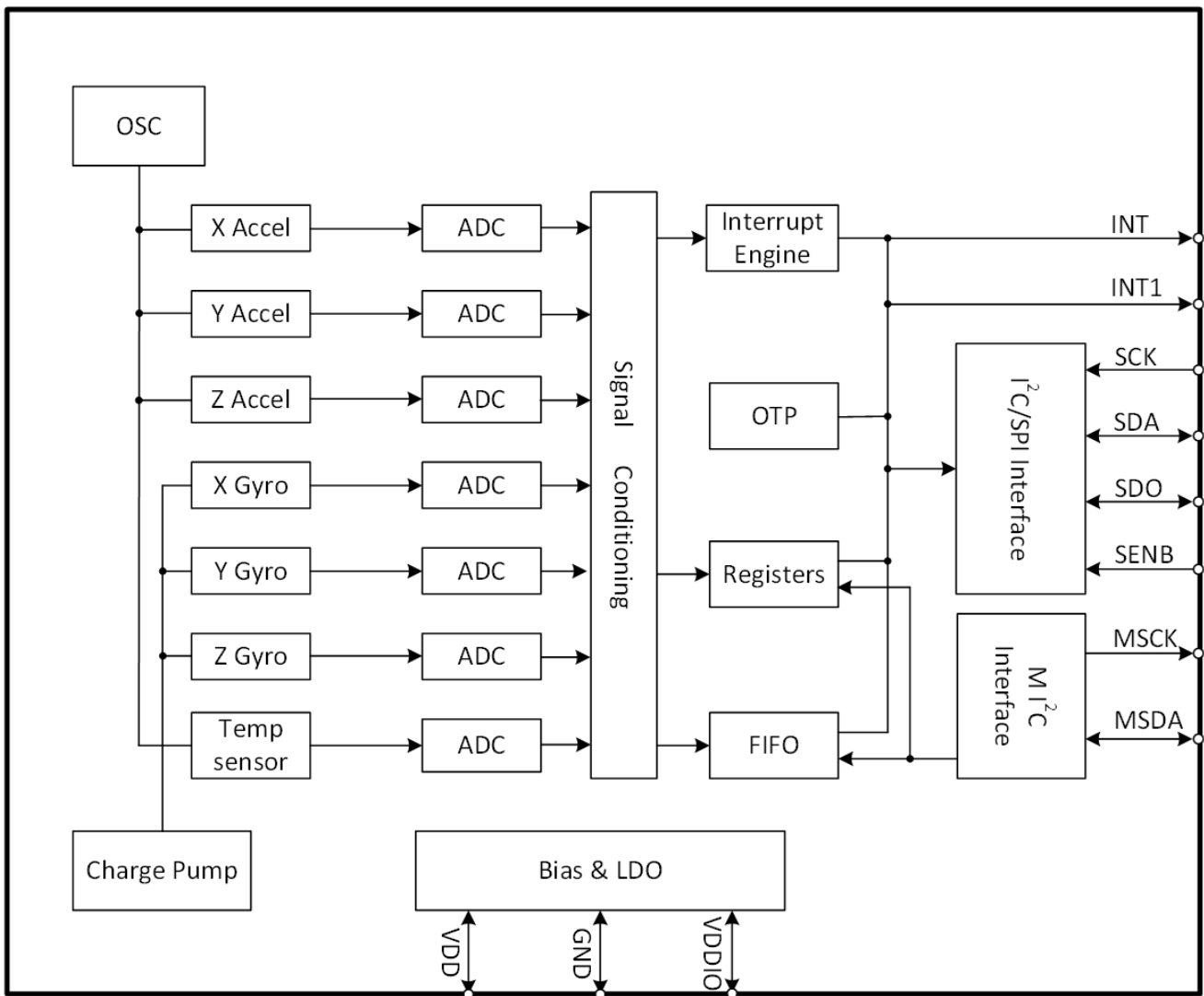

Figure 1: Functional diagram of the device



### 3 SH3001 Specifications

All parameters specified are tested at VDD=3.0V and T=25°C, unless otherwise noted.

#### 3.1 Gyroscope Specifications

Table 1: Gyroscope specifications

| Parameter                     | Condition                               | Min | Typ    | Max | Unit     |
|-------------------------------|---|-----|--------|-----|----------|
| Full Scale Range              | Selectable via serial digital interface |     | ± 125  |     | dps      |
|                               |   |     | ± 250  |     | dps      |
|                               |   |     | ± 500  |     | dps      |
|                               |   |     | ± 1000 |     | dps      |
|                               |   |     | ± 2000 |     | dps      |
| Sensitivity                   | Selectable via serial digital interface |     | 262    |     | LSB/dps  |
|                               |   |     | 131    |     | LSB/dps  |
|                               |   |     | 65.5   |     | LSB/dps  |
|                               |   |     | 32.8   |     | LSB/dps  |
|                               |   |     | 16.4   |     | LSB/dps  |
| Nonlinearity                  | Best fit straight line                  |     | ± 0.2  |     | %FS      |
| Cross-axis Sensitivity        |   |     | ± 1    |     | %        |
| Sensitivity Temperature Drift | -40°C - 85°C                            |     | ± 0.02 |     | %/°C     |
| Zero Rate Temperature Drift   | -40°C - 85°C                            |     | ± 0.05 |     | dps/°C   |
| Zero Rate Offset              |   |     | ± 1    |     | dps      |
| Output Noise Density          |   |     | 10     |     | mdps/√Hz |
| Output Data Rate              | Selectable via serial digital interface |     | 31     |     | Hz       |
|                               |   |     | 63     |     | Hz       |
|                               |   |     | 125    |     | Hz       |
|                               |   |     | 250    |     | Hz       |
|                               |   |     | 500    |     | Hz       |
|                               |   |     | 1000   |     | Hz       |
|                               |   |     | 2000   |     | Hz       |
|                               |   |     | 4000   |     | Hz       |
|                               |   |     | 8000   |     | Hz       |
|                               |   |     | 16000  |     | Hz       |
|                               | 32000                                   |     | Hz     |     |          |

### 3.2 Accelerometer Specifications

Table 2: Accelerometer specifications

| Parameter                     | Condition                               | Min | Typ       | Max | Unit          |
|-------------------------------|---|-----|-----------|-----|---------------|
| Full Scale Range              | Selectable via serial digital interface |     | ± 2       |     | <i>g</i>      |
|                               |   |     | ± 4       |     | <i>g</i>      |
|                               |   |     | ± 8       |     | <i>g</i>      |
|                               |   |     | ± 16      |     | <i>g</i>      |
| Sensitivity                   | Selectable via serial digital interface |     | 16384     |     | <i>LSB/g</i>  |
|                               |   |     | 8192      |     | <i>LSB/g</i>  |
|                               |   |     | 4096      |     | <i>LSB/g</i>  |
|                               |   |     | 2048      |     | <i>LSB/g</i>  |
| Nonlinearity                  | Best fit straight line                  |     | ± 0.5     |     | <i>%FS</i>    |
| Cross-axis Sensitivity        |   |     | ± 2       |     | <i>%</i>      |
| Sensitivity Temperature Drift | -40°C - 85°C                            |     | ± 0.01    |     | <i>%/°C</i>   |
| Zero_g Temperature Drift      | -40°C - 85°C                            |     | ± 1       |     | <i>mg/°C</i>  |
| Zero_Offset                   |   |     | ± 50      |     | <i>mg</i>     |
| Output Noise Density          |   |     | 220       |     | <i>µg/√Hz</i> |
| Output Data Rate              | Selectable via serial digital interface |     | 16        |     | <i>Hz</i>     |
|                               |   |     | 31        |     | <i>Hz</i>     |
|                               |   |     | 63        |     | <i>Hz</i>     |
|                               |   |     | 125       |     | <i>Hz</i>     |
|                               |   |     | 250       |     | <i>Hz</i>     |
|                               |   |     | 500       |     | <i>Hz</i>     |
|                               |   |     | 1000      |     | <i>Hz</i>     |
|                               |   |     | 2000      |     | <i>Hz</i>     |
|                               |   |     | 4000      |     | <i>Hz</i>     |
|                               | 8000                                    |     | <i>Hz</i> |     |               |

### 3.3 Temperature Sensor Specifications

Table 3: Temperature sensor specifications

| Parameter               | Condition                               | Min | Typ               | Max | Unit   |
|-------------------------|---|-----|-------------------|-----|--------|
| Operating Range         |   | -40 |                   | 85  | °C     |
| 25 °C Output            |   |     | 2500 <sup>1</sup> |     | LSB    |
| Resolution <sup>2</sup> |   |     | 12                |     | bit    |
| Sensitivity             |   |     | 16                |     | LSB/°C |
| Sensitivity Error       |   | -1  |                   | 1   | %      |
| Output Data Rate        | Selectable via serial digital interface |     | 500               |     | Hz     |
|                         |   |     | 250               |     | Hz     |
|                         |   |     | 125               |     | Hz     |
|                         |   |     | 63                |     | Hz     |

1. This is just an empirical value. Using the factory calibrated room temperature offset is recommended for calculating the temperature value.
2. The temperature sensor reading is a 12-bit unsigned value. Refer to 5.2 for further information on how to convert the readings to degrees centigrade.

### 3.4 Power Modes

Table 4: Power modes

| Mode       | Condition        | Min | Typ  | Max | Unit |
|------------|------------------|-----|------|-----|------|
| Normal     | High performance |     | 1650 |     | μA   |
| Sleep      | Accel only       |     | 162  |     | μA   |
| Power Down |                  |     | 14   |     | μA   |

The device has two distinct power supply pins: VDD is the main power supply, VDDIO is separate power supply pin for the interface and auxiliary interface. There are no limitations with the voltage level applied to the VDD and VDDIO pins, as long as it lies within the voltage operating range. The device can be completely switched off (VDD=VDDIO=0), all interface pins (SCK/SDA/SEN/SDO) must be kept close to GND. The device is not allowed switched off (VDD=0) while keeping the VDDIO supply. The device will be reset when the supply voltage applied to VDD, VDDIO delayed by more than 10ms after VDD. No constraints exist for the slow-rate of the voltage applied to the VDD and VDDIO pins.

### 3.5 Electrical Characteristics

Table 5: Electrical characteristics

| Symbol          | Parameter                         | Condition | Min       | Typ  | Max      | Unit |
|-----------------|-----------------------------------|-----------|-----------|------|----------|------|
| VDD             | Supply Voltage                    |           | 1.71      | 3.00 | 3.60     | V    |
| VDDIO           | Supply Voltage I/O                |           | 1.71      | 1.80 | 3.60     | V    |
| I <sub>dd</sub> | Supply Current                    | VDD=3.0V  |           | 1.65 |          | mA   |
| V <sub>IL</sub> | Digital Low-level Input Voltage   |           |           |      | 0.3VDDIO | V    |
| V <sub>IH</sub> | Digital High-level Input Voltage  |           | 0.7VDDIO  |      |          | V    |
| V <sub>OL</sub> | Digital Low-level Output Voltage  |           |           |      | 0.2      | V    |
| V <sub>OH</sub> | Digital High-level Output Voltage |           | VDDIO-0.2 |      |          | V    |

### 3.6 Digital Interface Characteristics

#### 3.6.1 Serial Peripheral Interface (SPI)

Subject to general operation conditions like VDD, operating temperature and PCB design.

Table 6: SPI interface characteristics

| Symbol             | Parameter        | Min | Max | Unit |
|--------------------|------------------|-----|-----|------|
| t <sub>sck</sub>   | SPI Clock Period | 1   |     | μs   |
| f <sub>sck</sub>   | SPI Frequency    |     | 1   | MHz  |
| t <sub>sucsb</sub> | CSB Setup Time   | 20  |     | ns   |
| t <sub>hcsb</sub>  | CSB Hold Time    | 20  |     | ns   |
| t <sub>susdi</sub> | SDI Setup Time   | 20  |     | ns   |
| t <sub>hsdi</sub>  | SDI Hold Time    | 20  |     | ns   |
| t <sub>vdso</sub>  | SDO Valid Time   |     | 120 | ns   |
| t <sub>hsdo</sub>  | SDO Hold Time    | 20  |     | ns   |
| t <sub>disso</sub> | SDO Disable Time |     | 150 | ns   |

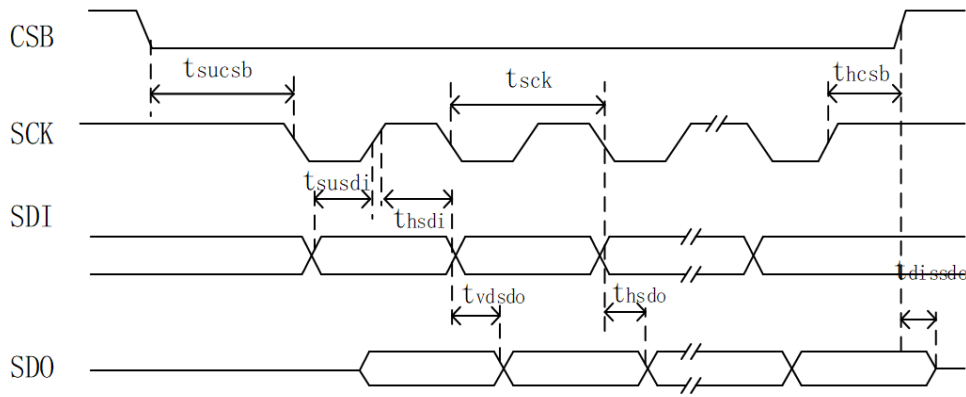

Figure 2: SPI timing diagram

### 3.6.2 Inter-Integrated Circuit (I<sup>2</sup>C)

Subject to general operation conditions like VDD, operating temperature and PCB design.

Table 7: I<sup>2</sup>C interface characteristics

| Symbol       | Parameter                         | Min | Max | Unit    |
|--------------|-----------------------------------|-----|-----|---------|
| $f_{sck}$    | I <sup>2</sup> C Frequency        |     | 1   | MHz     |
| $t_{low}$    | I <sup>2</sup> C Clock Low Time   | 0.5 |     | $\mu s$ |
| $t_{high}$   | I <sup>2</sup> C Clock High Time  | 0.3 |     | $\mu s$ |
| $t_{sudat}$  | SDA Data Setup Time               | 150 |     | ns      |
| $t_{hdat}$   | SDA Data Hold Time                | 0   | 1   | $\mu s$ |
| $t_{sursta}$ | Repeat Start Condition Setup Time | 0.5 |     | $\mu s$ |
| $t_{hsta}$   | Start Condition Hold Time         | 0.5 |     | $\mu s$ |
| $t_{susp}$   | Stop Condition Setup Time         | 0.5 |     | $\mu s$ |

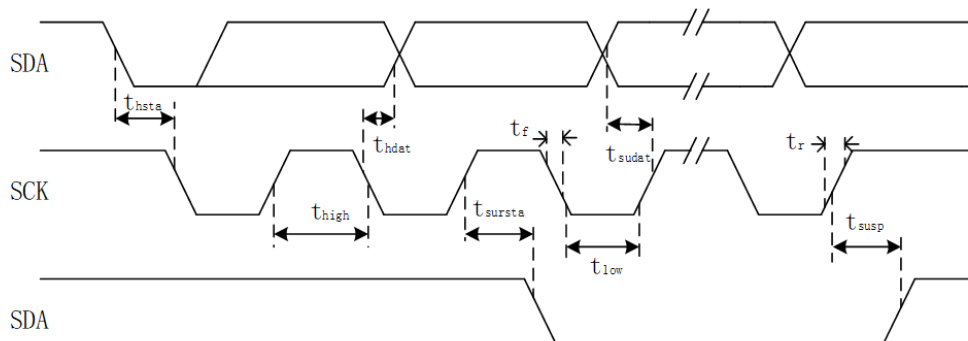

Figure 3: I<sup>2</sup>C timing diagram

### 3.7 Absolute Maximum Ratings

Table 8: Absolute maximum ratings

| Parameter                   | Rating                   | Unit |
|-----------------------------|--------------------------|------|
| Voltage at Supply Pin       | -0.6 - 3.6               | V    |
| Operating Temperature Range | -40 - 85                 | °C   |
| Storage Temperature Range   | -40 - 105                | °C   |
| ESD (HBM)                   | 2000                     | V    |
| ESD (MM)                    | 200                      | V    |
| Latch_up                    | JEDEC78E Class I, ±200mA | NA   |
| Mechanical Shock            | 10000g@0.2ms half sine   | NA   |

Note: Stress above those listed as 'Absolute Maximum Ratings' may cause permanent damage to the device. Exposure to absolute-maximum-rated conditions for extended periods may affect device reliability.

## 4 Pin Description

### 4.1 Pin Out View

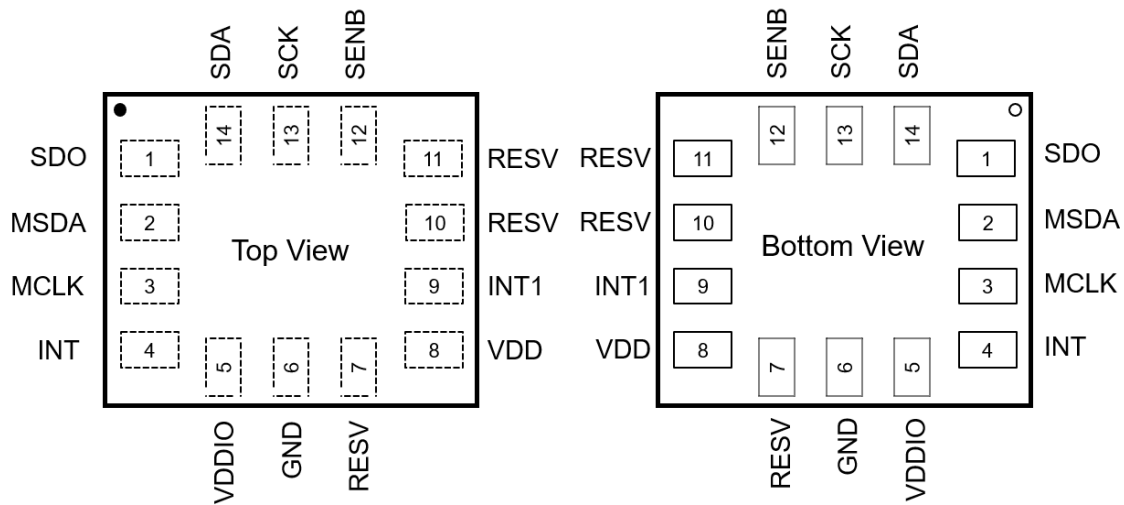

Figure 4: The pin out view of SH3001

### 4.2 Pin Descriptions

Table 9: Pin descriptions

| Pin No. | Pin Name | Description   |
|---------|----------|---|
| 1       | SDO      | I <sup>2</sup> C slave address LSB (A0), serial data output in SPI  |
| 2       | MSDA     | Auxiliary I <sup>2</sup> C serial data. Connect to external sensors or VDDIO or GND.  |
| 3       | MCLK     | Auxiliary I <sup>2</sup> C serial clock. Connect to external sensors or VDDIO or GND.   |
| 4       | INT      | Interrupt digital output(totem pole or open-drain). Connect to VDDIO.   |
| 5       | VDDIO    | Digital I/O supply voltage.   |
| 6       | GND      | Ground for power supply.  |
| 7       | RESV     | No connect or connect to VDDIO or GND.  |
| 8       | VDD      | Power supply voltage and digital supply voltage.  |
| 9       | INT1     | Interrupt 1 digital output(totem pole or open-drain). Connect to VDDIO.   |
| 10      | RESV     | No connect or connect to GND or VDDIO.  |
| 11      | RESV     | No connect or connect to VDDIO or connect to GND.   |
| 12      | SENB     | I <sup>2</sup> C/SPI (CSB) protocol select. 1: SPI idle mode/ I <sup>2</sup> C communication enabled; 0: SPI communication mode/ I <sup>2</sup> C disabled. |
| 13      | SCK      | I <sup>2</sup> C serial clock, SPI serial clock.  |
| 14      | SDA      | I <sup>2</sup> C serial data, serial data input SDI in SPI.   |

## 5 Functional Explanations

### 5.1 Six–Axis MEMS Sensor With 16-bit ADCs and Signal Conditioning

SH3001 consists of a three-axis angular rate sensor and a three-axis acceleration sensor. It detects rotation and acceleration on the X, Y and Z axes. The resulting signal is amplified, demodulated, and filtered to produce a voltage that is proportional to the angular rate or the acceleration. For each axis an on-chip 16-bit ADC is used to digitize the output voltage. The full-range of the gyroscope is programmable at  $\pm 125\text{ dps}$ ,  $\pm 250\text{ dps}$ ,  $\pm 500\text{ dps}$ ,  $\pm 1000\text{ dps}$  and  $\pm 2000\text{ dps}$  and the full-range of the accelerometer is programmable at  $\pm 2\text{ g}$ ,  $\pm 4\text{ g}$ ,  $\pm 8\text{ g}$  and  $\pm 16\text{ g}$ .

### 5.2 Digital Output Temperature Sensor

An on-chip temperature sensor is used to measure chip temperature of SH3001. It is enabled by setting 0x20[7] to '1' and 0xD5[2] to '0'. The readings from the sensor can be read from the TEMP\_DATA registers (0x0D[3:0] and 0x0C[7:0]) and the factory calibrated room temperature offset is stored in the ROOM\_TEMP registers (0x20[3:0] and 0x21[7:0]).

Both temperature readings and room temperature are 12-bit unsigned values and the temperature value can be converted to degrees centigrade by using the following formula:

Temperature ( $^{\circ}\text{C}$ ) = (TEMP\_DATA - ROOM\_TEMP)/16 + 25

### 5.3 Auxiliary I<sup>2</sup>C Serial Interface

SH3001 contains an auxiliary I<sup>2</sup>C bus which allows an external system processor to act as master and directly communicates to external sensors connected to the secondary I<sup>2</sup>C bus pins (MSDA and MSCK) by setting 0xFD[0] to '1'. This is useful for configuring external devices, or for keeping SH3001 in a low-power mode. In this mode, the secondary I<sup>2</sup>C bus control logic (third-party sensor interface block) of the SH3001 is disabled, and the secondary I<sup>2</sup>C pins MSDA and MSCK are connected to the main I<sup>2</sup>C bus through analog switches.

### 5.4 FIFO

SH3001 contains a 1kB FIFO that is accessible via the serial interface. The FIFO configuration register determines which data is written into the FIFO. Possible choices include gyroscope data, accelerometer data, temperature readings and auxiliary I<sup>2</sup>C device input. Down sampling of both gyroscope and accelerometer data can be configured in register 0x39.

It can work in 4 modes determined by register 0x35[1:0].

Disable: FIFO is not operational and it remains empty.

FIFO Mode: Data from measurements are stored in FIFO. When the number of samples in FIFO equals the level specified in the watermark register (0x37[2:0] and 0x36[7:0]), the watermark interrupt is fired. FIFO continues to accumulate data until it is full and then stops collecting data. The watermark interrupt continues to occur until the number of samples in FIFO is less than the value stored in the watermark register.

Stream Mode: Data from measurements are stored in FIFO. When the number of samples in FIFO



equals the level specified in the watermark register, the watermark interrupt bit is set. FIFO continues accumulating samples and holds the latest samples, discarding older data as new data arrives; The watermark interrupt continues to occur until the number of samples in FIFO is less than the value stored in the watermark register.

**Trigger Mode:** FIFO accumulates samples, holding the latest samples from measurements. After a trigger event occurs and an interrupt is sent, FIFO keeps the last n samples (where n is the value specified by the watermark register) and then operates in FIFO mode, collecting new samples only when FIFO is not full.

Note that the FIFO data should be read first because setting the device into FIFO disable mode clears FIFO.

## 5.5 Interrupt

### 5.5.1 General Features

SH3001 contains 13 programmable interrupts and utilizes output pin INT or INT1 to send signal to an external microprocessor as an interrupt event occurs. Interrupts can be enabled or disabled by configuring interrupt control registers. The status register will be read by the external microprocessor to check the types of interrupt. There are three interrupt modes: automatically clear, latched and non-latched. New data ready interrupt is automatically cleared after a fixed time. Other interrupts can be configured as latched (set 0x44[6] to '0') or non-latched (set 0x44[6] to '1') modes. Non-latched interrupts will be cleared after a defined period of time (defined by 0x45). For latched interrupts, there are two ways to clear the interrupts: random read clear (set 0x44[4] to '1') or status read clear (set 0x44[4] to '0').

The interrupt pins can be set as either open-drain output or normal output by configuring register 0x44[2] for pin INT1 and 0x44[0] for pin INT. When setting register value to '1' ('0'), the output pin is open-drain (normal) output. The active level of interrupt pins is determined by register 0x44[7]. When setting register 0x44[7] to '0' ('1'), the active level of interrupt pins is active high (low).

All the thresholds for interrupts are unsigned values.

Table 10: Interrupts supported by SH3001

| Index | Interrupt Name            | Enable      | Pin Assigning | Flag                |
|-------|---------------------------|-------------|---------------|---------------------|
| 1     | Inactivity Interrupt      | 0x40[5]     | 0x79[6]       | 0x10[0] & 0x14[7:4] |
| 2     | Activity Interrupt        | 0x40[4]     | 0x79[5]       | 0x10[1] & 0x14[7:4] |
| 3     | Double Tap Interrupt      | 0x40[3]     | 0x79[3]       | 0x10[2] & 0x14[3:0] |
| 4     | Single Tap Interrupt      | 0x40[2]     | 0x79[2]       | 0x10[3] & 0x14[3:0] |
| 5     | Tap Interrupt             | 0x40[2]/[3] | 0x79[4]       | 0x10[4] & 0x14[3:0] |
| 6     | Flat Interrupt            | 0x40[1]     | 0x79[1]       | 0x10[5]             |
| 7     | Orient Interrupt          | 0x40[0]     | 0x79[0]       | 0x10[6]             |
| 8     | Free Fall Interrupt       | 0x41[0]     | 0x7A[1]       | 0x10[7]             |
| 9     | Water Mark Interrupt      | 0x41[4]     | 0x7A[5]       | 0x11[0]             |
| 10    | Gyro Data Ready Interrupt | 0x41[3]     | 0x7A[4]       | 0x11[1]             |
| 11    | Acc Data Ready Interrupt  | 0x41[1]     | 0x7A[2]       | 0x11[3]             |
| 12    | Low-G Interrupt           | 0x40[7]     | 0x7A[0]       | 0x12[0]             |
| 13    | High-G interrupt          | 0x40[6]     | 0x79[7]       | 0x12[7:4]           |

### 5.5.2 Inactivity Interrupt

Inactivity detection uses consecutive acceleration values to detect lack of motion. Inactivity interrupt is enabled (disabled) by writing '1' ('0') to register 0x40[5]. There are two types of operation for inactivity detection: AC Mode and DC Mode. By writing '1' ('0') to register 0x4F[3], AC Mode (DC Mode) operation is selected.

In AC Mode operation for inactivity detection, if the slopes of all axes is lower than preset threshold defined by 0x57, and hold time is longer than that set in 0x58, the interrupt is fired.

In DC Mode operation, the square of current acceleration magnitude is compared with the *INACT\_THR* defined by the *INACT\_INT\_THR* registers (0x7C: high byte, 0x7B: middle byte and 0x57: low byte) to determine whether inactivity is detected. The square of current acceleration magnitude is defined as follows:

$$Curr\_Acc^2 = |acc\_x^2 + acc\_y^2 + acc\_z^2 - 1G^2| \quad (1)$$

The reference 1G in the above equation is defined by the register 0x7E and 0x7D. If  $Curr\_Acc^2 < 64 \times INACT\_THR$ , inactivity interrupt is fired.

Each axis can be individually selected to participate in detecting inactivity. The axis participates the inactivity detection is determined by register 0x4F[2:0]. A setting of 0 excludes the selected axis from participation. If all axes are excluded, the function is disabled. For inactivity detection, all participating axes are logically AND, causing the inactivity function to trigger when all of the participating axes are less than the threshold for at least a period of time specified in register 0x58.

The interrupt status is stored in register 0x10[0] and 0x14[7:4]. The inactivity interrupt supplies additional information about the detected inactivity. The axis that triggers the interrupt is indicated by register 0x14[6:4] that contains a value of '1'. The sign of the triggering slope is held in register 0x14[7] until the interrupt is retriggered. If register 0x14[7] = '0' ('1'), the sign is positive (negative).

### 5.5.3 Activity Interrupt

Activity detection uses consecutive acceleration values to detect changes in motion. Activity detection interrupt is enabled (disabled) by writing '1' ('0') to register 0x40[4]. There are two types of operation for activity detection: AC Mode and DC Mode. By writing '1' ('0') to register 0x4F[7], AC Mode (DC Mode) operation is selected.

The activity interrupt threshold is defined by register 0x55.

In DC Mode operation, the current acceleration magnitude is compared directly with activity interrupt threshold to determine whether activity is detected.

In AC Mode operation for activity detection, the acceleration value at the start of activity detection is taken as a reference value. New samples of acceleration are then compared to this reference value. If the magnitude of the difference exceeds the activity interrupt threshold, activity interrupt is fired.

Activity interrupt is generated only after a predefined number of consecutive acceleration values exceed the value defined by 0x55. The number is set by the register 0x56.

Each axis can be individually selected to participate in detecting activity. The axis participates activity detection is determined by register 0x4F[6:4]. A setting of '0' excludes the selected axis from participation. If all axes are excluded, the function is disabled. For activity detection, all participating axes are logically OR, causing the activity function to trigger when any of the participating axes exceeds the activity threshold for consecutive number of samples defined by register 0x56.

The interrupt status is stored in register 0x10[1]. The activity interrupt supplies additional information about the detected activity. The axis which triggers the interrupt is given by register 0x14[6:4] that contains a value of '1'. The sign of the triggering slope is held in register 0x14[7] until the interrupt is retriggered. If register 0x14[7] = '0' ('1'), the sign is positive (negative).

### 5.5.4 Double & Single Tap Interrupt

A tap event is detected if a pre-defined slope of the acceleration of at least one axis exceeds the threshold. Two different tap events are distinguished : a 'Single Tap' is a single event within a certain time and a 'Double Tap' consists of a single tap followed by a second event within a defined period of time.

- Step 1: The absolute value/64 of an axis is more than preset threshold through 0x51.
- Step 2: The large value last time should shorter than the period defined by 0x52; Single Tap is recognized, but need to prove no Double Tap.
- Step 3: Disable value comparator before the duration end which is set by 0x53.
- Step 4: Compare absolute value with threshold within the duration set by 0x54; If no large sample detected in this duration, Single Tap Interrupt is fired. Else go to Step 5.
- Step 5: If the large value last time is longer than the period defined by 0x52, Single Tap is proved. Otherwise, Double Tap is proved.

### 5.5.5 Tap Interrupt

Both Single Tap and Double Tap will cause Tap Interrupt.

### 5.5.6 Flat Interrupt

The flat detection feature gives information about the orientation of the device's z-axis relative to the g-vector. It recognizes whether the device is in a flat position or not. The flat angle  $\theta$  is defined as:

$$\theta = \text{atan}\left(\sqrt{\frac{\text{acc}_x^2 + \text{acc}_y^2}{\text{acc}_z^2}}\right) \quad (2)$$

in the above equation,  $\text{acc}_x, \text{acc}_y, \text{acc}_z$  are the x, y and z axis outputs of the accelerometer. If  $\text{acc}_x = \text{acc}_y = 0$  and  $\text{acc}_z = 1g$ ,  $\theta = 0$ , indicating that the device is in a totally flat position. Similarly, the value of  $8 \times \tan^2\theta$  is compared with the threshold value defined by 0x4E[5:0] by the interrupt engine. If  $8 \times \tan^2\theta$  is less than the threshold and keeps enough time defined in 0x4E[7:6], Flat Interrupt is fired.

### 5.5.7 Orientation Interrupt

The orientation interrupt informs on an orientation change of the sensor with respect to the gravitational field vector  $g$ . There are the orientations upward/downward and orthogonal to that portrait upright, landscape left, portrait downside, and landscape right.

The sensor orientation is defined by the angles  $\varphi$  and  $\theta$  ( $\varphi$  is rotation around the stationary z axis and  $\theta$  is rotation around the stationary y axis). Therefore the magnitudes of the acceleration vectors are calculated as follows:

$$\begin{cases} \text{acc}_x = 1g \times \sin\theta \times \cos\varphi \\ \text{acc}_y = -1g \times \sin\theta \times \sin\varphi \\ \text{acc}_z = 1g \times \cos\theta \end{cases} \quad (3)$$

According to equation 3, if the outputs of three axes are given, the orientation angles are calculated as follows:

$$\begin{cases} \varphi = -\text{atan}\left(\frac{\text{acc}_y}{\text{acc}_x}\right) \\ \theta = \text{atan}\left(\sqrt{\frac{\text{acc}_x^2 + \text{acc}_y^2}{\text{acc}_z^2}}\right) \end{cases} \quad (4)$$

Depending on the value of orientation angles the orientation of the device in space is determined and stored in the orientation status register 0x15[2:0]. There are three orientation calculation modes: symmetrical, high-asymmetrical and low-asymmetrical. The mode is selected by the register 0x47[1:0].

The engine uses 16-bit acceleration data for the orientation recognition. For upside or downside orientation, 0x15[2] has the definition:

0 → Upward  $\text{acc}_z > 0$

1 → Downward  $\text{acc}_z < 0$

Both portrait/landscape and upside/downside recognition use a hysteresis (*hyst*) which is decided by 0x4D and 0x4C. For each orientation mode, 0x47[1:0] has different meanings as shown in the following tables.

Table 11: Meaning of the orient mode register in symmetrical mode

| 0x15[1:0] | Name                 | Condition   |
|-----------|----------------------|---|
| 00        | Landscape left       | $ acc\_y  <  acc\_x  - hyst \quad \& \quad acc\_x \geq 0$ |
| 01        | Landscape right      | $ acc\_y  <  acc\_x  - hyst \quad \& \quad acc\_x \leq 0$ |
| 10        | Portrait upside down | $ acc\_y  >  acc\_x  + hyst \quad \& \quad acc\_y \leq 0$ |
| 11        | Portrait upright     | $ acc\_y  >  acc\_x  + hyst \quad \& \quad acc\_y \geq 0$ |

Table 12: Meaning of the orient mode register in high-asymmetrical mode

| 0x15[1:0] | Name                 | Condition  |
|-----------|----------------------|--|
| 00        | Landscape left       | $ acc\_y  < 2 \times ( acc\_x  - hyst) \quad \& \quad acc\_x \geq 0$ |
| 01        | Landscape right      | $ acc\_y  < 2 \times ( acc\_x  - hyst) \quad \& \quad acc\_x \leq 0$ |
| 10        | Portrait upside down | $ acc\_y  > 2 \times  acc\_x  + hyst \quad \& \quad acc\_y \leq 0$   |
| 11        | Portrait upright     | $ acc\_y  > 2 \times  acc\_x  + hyst \quad \& \quad acc\_y \geq 0$   |

Table 13: Meaning of the orient mode register in low-asymmetrical mode

| 0x15[1:0] | Name                 | Condition   |
|-----------|----------------------|---|
| 00        | Landscape left       | $ acc\_y  < ( acc\_x  - hyst)/2 \quad \& \quad acc\_x \geq 0$ |
| 01        | Landscape right      | $ acc\_y  < ( acc\_x  - hyst)/2 \quad \& \quad acc\_x \leq 0$ |
| 10        | Portrait upside down | $ acc\_y  >  acc\_x /2 + hyst \quad \& \quad acc\_y \leq 0$   |
| 11        | Portrait upright     | $ acc\_y  >  acc\_x /2 + hyst \quad \& \quad acc\_y \geq 0$   |

It is possible to block the Orientation Interrupt. The Orientation Interrupt blocking feature is configured via 0x47[3:2]. The value of '1.5g' is defined by 0x49 and 0x48. The value of the slope threshold is defined by 0x4B and 0x4A.

The meaning of 0x47[3:2] is listed as follows:

'00': Orientation Interrupt blocking is disabled.

'01': Orientation Interrupt will be blocked if the device is close to the horizontal position or acceleration of any axis is larger than 1.5g.

'10': Orientation Interrupt will be blocked if the device is close to the horizontal position or acceleration of any axis is larger than 1.5g or the slope is larger than 0.2g.

'11': Orientation Interrupt will be blocked if the device is close to the horizontal position or the slope is larger than 0.4g or acceleration of any axis is larger than 1.5g or another orientation change is detected within 100ms.

### 5.5.8 FIFO Watermark Interrupt

Generate interrupt when FIFO data count is equal to the hold level defined in 0x37[2:0] and 0x36.

### 5.5.9 Gyroscope Data Ready Interrupt

Generate interrupt when gyroscope data is ready. If interrupt is not latched, INT can be consider as a clock signal with programmable duty cycle and right INT\_Length settings.

### 5.5.10 Accelerometer Data Ready Interrupt

Generate interrupt when accelerometer data is ready. If interrupt is not latched, INT can be consider as a clock signal with programmable duty cycle and right INT\_Length settings.

### 5.5.11 Free-fall Interrupt

Free-fall detection detects whether the device is falling. If the sum of absolute accelerations of all three axes  $|acc_x| + |acc_y| + |acc_z|$  is less than the threshold set by register 0x5E for a period time longer than the value is specified in the register 0x5F, free-fall interrupt is generated. The free-fall interrupt is enabled (disabled) by writing '1' ('0') to register 0x41[0] and the interrupt status is stored in register 0x10[7].

The register 0x5E defines the threshold value. The meaning of register 0x5E depends on the range setting. The sum of absolute acceleration of all axes  $|acc_x| + |acc_y| + |acc_z|$  is compared with the value in register 0x5E to determine if a free-fall event occurred.

The register 0x5F defines the time value representing the minimum time that the value of all axes must be less than register 0x5E to generate a free-fall interrupt. The scale factor is 2ms/LSB. A value of 0 may result in undesirable behavior if the free-fall interrupt is enabled. Values between 100 ms and 350 ms (0x32 to 0xAF) are recommended.

### 5.5.12 Low-G Interrupt

Low-G interrupt is based on the comparison of acceleration data against a low-g threshold defined in 0x5C. If the absolute values of the acceleration of all axes are lower than the threshold and last time is longer than the period defined in 0x5D, Low-G interrupt is fired.

### 5.5.13 High-G Interrupt

High-G Interrupt is based on the comparison of acceleration data against a high-g threshold defined in 0x5A. If the absolute value of enabled axis is larger than the high-g threshold and last time is longer than the period defined in 0x5B, High-G interrupt is fired .

## 6 Digital Interfaces

### 6.1 General Description

SH3001 has both primary (I<sup>2</sup>C and SPI configurable) and secondary interfaces. The secondary interface supports I<sup>2</sup>C only. The secondary I<sup>2</sup>C bus allows an external processor to act as master and communicates with the external device connected to the secondary I<sup>2</sup>C bus pins (MSDA and MSCK). This is useful for configuring a magnetometer along with SH3001 to build a 9-DoF solution. In this mode, the secondary I<sup>2</sup>C bus control logic of SH3001 is disabled, and the secondary I<sup>2</sup>C pins MSDA and MSCK are connected to the main I<sup>2</sup>C bus through analog switches.

The diagram below shows an application processor can communicate with an external digital output sensor connected to SH3001 through the auxiliary I<sup>2</sup>C bus.

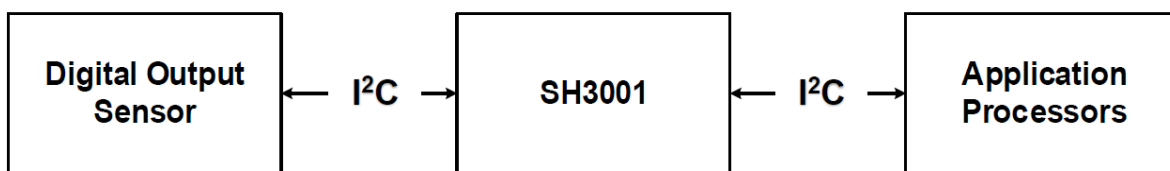

Figure 5: Connection diagram through the auxiliary I<sup>2</sup>C bus

### 6.2 Primary Interfaces

By default, SH3001 operates in I<sup>2</sup>C mode. It can also be configured to operate in SPI mode. I<sup>2</sup>C and SPI digital interfaces share partly the same pins.

#### 6.2.1 Primary Interface I<sup>2</sup>C/SPI Protocol Selection

The protocol is automatically selected based on the chip select CSB pin behavior after power-up. At power-up, SH3001 is in I<sup>2</sup>C mode. If CSB is connected to VDDIO during power-up and not changed then SH3001 works in I<sup>2</sup>C mode. The interface switches from I<sup>2</sup>C to SPI mode if a 'high' to 'low' transition happens on CSB pin.

#### 6.2.2 Primary SPI Interface

The SPI interface of SH3001 is compatible with two modes, '00' (CPOL = '0' and CPHA = '0') and '11' (CPOL = '1' and CPHA = '1'). The automatic selection between '00' and '11' is controlled based on the value of SCK after a falling edge of CSB. The page1 or page2 registers can be accessed by setting register 0x7F[0] to '0' or '1'.

The basic write, read and multiple write, read operations are illustrated in below waveforms.

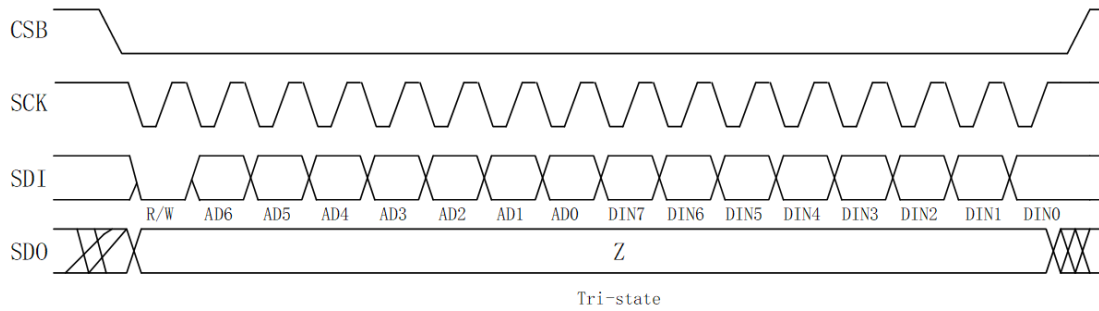

Figure 6: 4-wire SPI write sequence

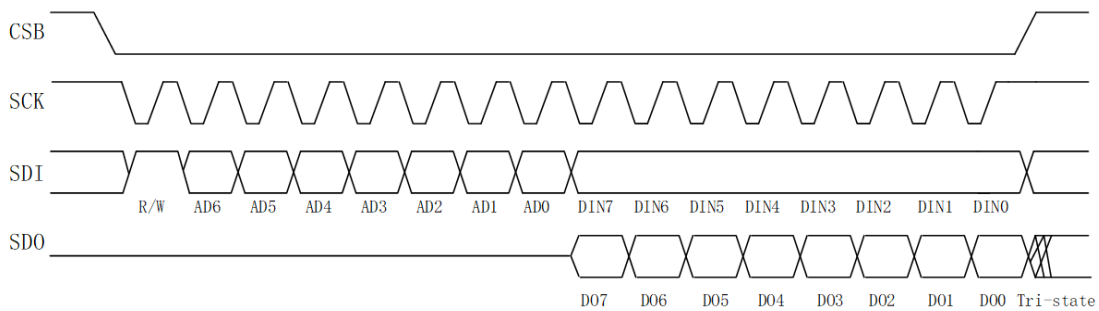

Figure 7: 4-wire SPI read sequence

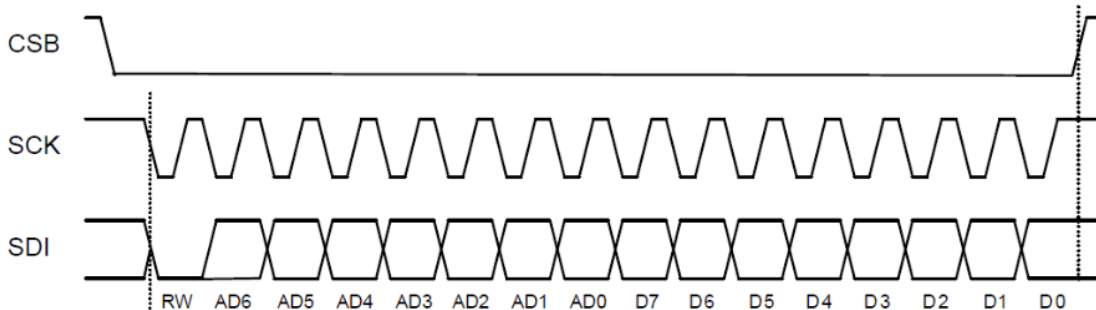

Figure 8: 3-wire SPI read and write sequence

The data bits shown in above waveforms are:

Bit[0]: Read/Write bit. When '0', the data SDI is written into the chip. When '1', the data SDO are read out from them chip.

Bit[1:7]: Address AD[6:0].

Bit[8:15]: In write mode, these are the data from SDI written into the address AD. In read mode, these are data read from the address AD.

Multiple read and write operations are done by keeping CSB low and continuing the data transaction and only the first address is written, addresses are automatically incremented internally as long as CSB stays active.

Multiple read and write are shown in figures below:



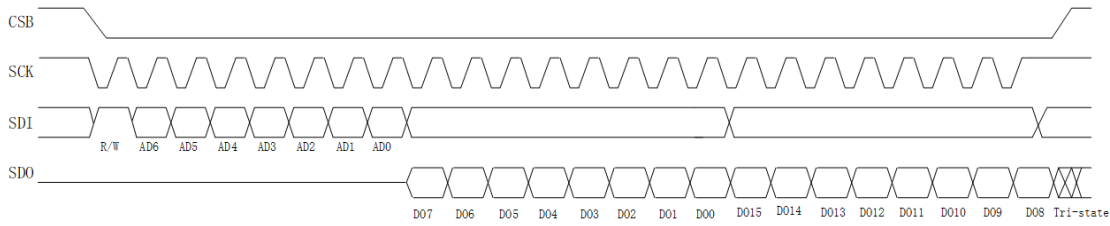

Figure 9: 4-wire SPI multiple read sequence

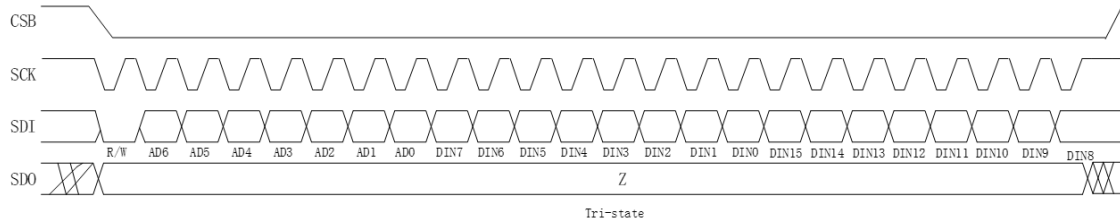

Figure 10: 4-wire SPI multiple write sequence

### 6.2.3 Primary I<sup>2</sup>C Interface

The I<sup>2</sup>C interface of SH3001 is a slave bus. There are two signals associated with the I<sup>2</sup>C bus: the serial clock SCL and serial data SDA. The SDA is a bi-directional line used to send or receive data from the interface. Both lines must be connected to VDDIO through external pull-up resistors.

The default I<sup>2</sup>C address of SH3001 is 0b0110110. It is used if the SDO pin is pulled to 'GND'. The alternative address 0b0110111 is selected by pulling SDO to 'VDDIO'.

The I<sup>2</sup>C bus is implemented with both fast mode (400 kHz) and standard mode.

Data transfer with acknowledge is mandatory. The transmitter must release the SDA line during the acknowledge pulse. The receiver then must pull the SDA line 'low' so it remains low during the high period of the acknowledge clock pulse. A receiver which has been addressed is obliged to generate an acknowledge after each byte of data received.

The transaction begins with a start (ST) condition generated by master, followed by 7 bits slave address (SAD) and 1 read/write bit, then the master sends the one byte register address (RAD). If it is a read operation, a repeated start (SR) condition must be issued after the register address byte. If it is a write operation, the master will transmit data which will be written into the register addressed by register address byte. The slave sends out slave acknowledge condition (ACK) after the slave address issued by master matches its slave address, and after master sends out register address and receives data byte written by master. The master must assert master acknowledge condition (MACK) after receives data from slave.

Data are transferred in byte format with MSB sent out first. The number of bytes transferred is unlimited until no master acknowledge (MNACK) condition asserted by master for read operation, or when master issues stop condition for write operation.

|        |    |       |     |      |     |      |     |    |
|--------|----|-------|-----|------|-----|------|-----|----|
| Master | ST | SAD+W |     | RADR |     | DATA |     | SP |
| Slave  |    |       | ACK |      | ACK |      | ACK |    |

Figure 11: I<sup>2</sup>C single byte write

|        |    |       |     |      |     |    |       |     |      |       |    |
|--------|----|-------|-----|------|-----|----|-------|-----|------|-------|----|
| Master | ST | SAD+W |     | RADR |     | RS | SAD+R |     |      | MNACK | SP |
| Slave  |    |       | ACK |      | ACK |    |       | ACK | DATA |       |    |

Figure 12: I<sup>2</sup>C single byte read

|        |    |       |     |      |     |      |     |      |     |    |
|--------|----|-------|-----|------|-----|------|-----|------|-----|----|
| Master | ST | SAD+W |     | RADR |     | DATA |     | DATA |     | SP |
| Slave  |    |       | ACK |      | ACK |      | ACK |      | ACK |    |

Figure 13: I<sup>2</sup>C multiple bytes write

|        |    |       |     |      |     |    |       |     |      |      |      |       |    |
|--------|----|-------|-----|------|-----|----|-------|-----|------|------|------|-------|----|
| Master | ST | SAD+W |     | RADR |     | RS | SAD+R |     |      | MACK |      | MNACK | SP |
| Slave  |    |       | ACK |      | ACK |    |       | ACK | DATA |      | DATA |       |    |

Figure 14: I<sup>2</sup>C multiple bytes read

## 7 Register Descriptions

### 7.1 Register Descriptions

#### 7.1.1 Register 0x00 - 0x05: Accelerometer Data

Name: ACC\_XDATA\_L

Address: 0x00

| Bit   | Access | Default | Description                 |
|-------|--------|---------|-----------------------------|
| [7:0] | RO     |         | Low byte of acc X-axis data |

Name: ACC\_XDATA\_H

Address: 0x01

| Bit   | Access | Default | Description                  |
|-------|--------|---------|------------------------------|
| [7:0] | RO     |         | High byte of acc X-axis data |

Name: ACC\_YDATA\_L

Address: 0x02

| Bit   | Access | Default | Description                 |
|-------|--------|---------|-----------------------------|
| [7:0] | RO     |         | Low byte of acc Y-axis data |

Name: ACC\_YDATA\_H

Address: 0x03

| Bit   | Access | Default | Description                  |
|-------|--------|---------|------------------------------|
| [7:0] | RO     |         | High byte of acc Y-axis data |

Name: ACC\_ZDATA\_L

Address: 0x04

| Bit   | Access | Default | Description                 |
|-------|--------|---------|-----------------------------|
| [7:0] | RO     |         | Low byte of acc Z-axis data |

Name: ACC\_ZDATA\_H

Address: 0x05

| Bit   | Access | Default | Description                  |
|-------|--------|---------|------------------------------|
| [7:0] | RO     |         | High byte of acc Z-axis data |

### 7.1.2 Register 0x06 - 0x0B: Gyroscope Data

Name: GYRO\_XDATA\_L  
Address: 0x06

| Bit   | Access | Default | Description                  |
|-------|--------|---------|------------------------------|
| [7:0] | RO     |         | Low byte of gyro X-axis data |

Name: GYRO\_XDATA\_H  
Address: 0x07

| Bit   | Access | Default | Description                   |
|-------|--------|---------|-------------------------------|
| [7:0] | RO     |         | High byte of gyro X-axis data |

Name: GYRO\_YDATA\_L  
Address: 0x08

| Bit   | Access | Default | Description                  |
|-------|--------|---------|------------------------------|
| [7:0] | RO     |         | Low byte of gyro Y-axis data |

Name: GYRO\_YDATA\_H  
Address: 0x09

| Bit   | Access | Default | Description                   |
|-------|--------|---------|-------------------------------|
| [7:0] | RO     |         | High byte of gyro Y-axis data |

Name: GYRO\_ZDATA\_L  
Address: 0x0A

| Bit   | Access | Default | Description                  |
|-------|--------|---------|------------------------------|
| [7:0] | RO     |         | Low byte of gyro Z-axis data |

Name: GYRO\_ZDATA\_H  
Address: 0x0B

| Bit   | Access | Default | Description                   |
|-------|--------|---------|-------------------------------|
| [7:0] | RO     |         | High byte of gyro Z-axis data |

### 7.1.3 Register 0x0C - 0x0D: Temperature Data

Name: TEMP\_DATA\_L  
Address: 0x0C

| Bit   | Access | Default | Description                    |
|-------|--------|---------|--------------------------------|
| [7:0] | RO     |         | Low 8 bits of temperature data |

Name: TEMP\_DATA\_H  
Address: 0x0D

| Bit   | Access | Default | Description                     |
|-------|--------|---------|---------------------------------|
| [7:4] |        |         | Reserved                        |
| [3:0] | RO     |         | High 4 bits of temperature data |

### 7.1.4 Register 0x0F: Chip ID

Name: CHIP\_ID  
Address: 0x0F

| Bit   | Access | Default  | Description                                |
|-------|--------|----------|--|
| [7:0] | RO     | 01100001 | The default Chip ID of this device is 0x61 |

### 7.1.5 Register 0x10 - 0x15: Interrupt Status

Name: INTERRUPT\_STATUS\_0  
Address: 0x10

| Bit | Access | Default | Description  |
|-----|--------|---------|--|
| 7   | RO     | 0       | Free-fall Interrupt status. 1: Active; 0: Not Active   |
| 6   | RO     | 0       | Orientation Interrupt status. 1: Active; 0: Not Active |
| 5   | RO     | 0       | Flat Interrupt status. 1: Active; 0: Not Active        |
| 4   | RO     | 0       | Tap Interrupt status. 1: Active; 0: Not Active         |
| 3   | RO     | 0       | Single Tap Interrupt status. 1: Active; 0: Not Active  |
| 2   | RO     | 0       | Double Tap Interrupt status. 1: Active; 0: Not Active  |
| 1   | RO     | 0       | Activity Interrupt status. 1: Active; 0: Not Active    |
| 0   | RO     | 0       | Inactivity Interrupt status. 1: Active; 0: Not Active  |

Name: INTERRUPT\_STATUS\_1  
Address: 0x11

| Bit   | Access | Default | Description  |
|-------|--------|---------|--|
| [7:4] |        |         | Reserved   |
| 3     | RO     | 0       | Acc Data Ready Interrupt status. 1: Active; 0: Not Active      |
| 2     | RO     | 0       | Acc FIFO Watermark Interrupt status. 1: Active; 0: Not Active  |
| 1     | RO     | 0       | Gyro Ready Interrupt status. 1: Active; 0: Not Active          |
| 0     | RO     | 0       | Gyro FIFO Watermark Interrupt status. 1: Active; 0: Not Active |

Name: INTERRUPT\_STATUS\_2

Address: 0x12

| Bit   | Access | Default | Description  |
|-------|--------|---------|--|
| 7     | RO     | 0       | Sign of acceleration that trigger High-G Interrupt. 1: Negative; 0: Positive |
| 6     | RO     | 0       | Whether High-G Interrupt is triggered by X axis. 1: Yes; 0: No               |
| 5     | RO     | 0       | Whether High-G Interrupt is triggered by Y axis. 1: Yes; 0: No               |
| 4     | RO     | 0       | Whether High-G Interrupt is triggered by Z axis. 1: Yes; 0: No               |
| [3:1] |        |         | Reserved   |
| 0     | RO     | 0       | Low-G Interrupt status, 1: Active; 0: Not Active                             |

Name: INTERRUPT\_STATUS\_3

Address: 0x14

| Bit | Access | Default | Description  |
|-----|--------|---------|--|
| 7   | RO     | 0       | Sign of acceleration that trigger Activity or Inactivity Interrupt. 1: Negative; 0: Positive |
| 6   | RO     | 0       | Whether Activity or Inactivity Interrupt is triggered by X axis. 1: Yes; 0: No               |
| 5   | RO     | 0       | Whether Activity or Inactivity Interrupt is triggered by Y axis. 1: Yes; 0: No               |
| 4   | RO     | 0       | Whether Activity or Inactivity Interrupt is triggered by Z axis. 1: Yes; 0: No               |
| 3   | RO     | 0       | Sign of acceleration that trigger Single or Double Tap Interrupt. 1: Negative; 0: Positive   |
| 2   | RO     | 0       | Whether Single or Double Tap Interrupt is triggered by X axis. 1: Yes; 0: No                 |
| 1   | RO     | 0       | Whether Single or Double Tap Interrupt is triggered by Y axis. 1: Yes; 0: No                 |
| 0   | RO     | 0       | Whether Single or Double Tap Interrupt is triggered by Z axis. 1: Yes; 0: No                 |

Name: INTERRUPT\_STATUS\_4  
Address: 0x15

| Bit   | Access | Default | Description   |
|-------|--------|---------|---|
| [7:3] |        |         | Reserved  |
| 2     | RO     | 0       | Orientation Interrupt Value of Z-axis. 1: Downward ; 0: Upward  |
| [1:0] | RO     | 00      | Orientation Interrupt Value of X and Y-axis. 00: Landscape left; 01: Landscape right; 10: Portrait upside down; 11: Portrait up-right |

### 7.1.6 Register 0x16 - 0x17: FIFO Status

Name: FIFO\_STATUS\_0  
Address: 0x16

| Bit   | Access | Default  | Description                        |
|-------|--------|----------|------------------------------------|
| [7:0] | RO     | 00000000 | Lower 8 bits of FIFO entries count |

Name: FIFO\_STATUS\_1  
Address: 0x17

| Bit   | Access | Default | Description   |
|-------|--------|---------|---|
| [7:6] |        |         | Reserved  |
| 5     | RO     | 0       | Whether FIFO Watermark has been reached. 1: Yes 0: No |
| 4     | RO     | 0       | Whether FIFO is full. 1: Yes 0: No                    |
| 3     | RO     | 0       | Whether FIFO is empty. 1: Yes 0: No                   |
| [2:0] | RO     | 000     | Higher 3 bits of FIFO entries count                   |

### 7.1.7 Register 0x18: FIFO Data

Name: FIFO\_Data  
Address: 0x18

| Bit   | Access | Default  | Description |
|-------|--------|----------|-------------|
| [7:0] | RO     | 00000000 | FIFO Data   |

### 7.1.8 Register 0x20 - 0x21 & 0xD5: Temperature Sensor Configuration

Name:TEMP\_SENSOR\_CONFIG0  
Address: 0x20

| Bit   | Access | Default | Description  |
|-------|--------|---------|--|
| 7     | RW     | 1       | Temp Sensor Enable (Digital). 0: Disable; 1: Enable        |
| 6     |        |         | Reserved   |
| [5:4] | RW     | 11      | Temp Sensor ODR. 00: 500Hz; 01: 250Hz; 10: 125Hz; 11: 63Hz |
| [3:0] | RW     |         | High 4 bits of room temperature                            |

Name:TEMP\_SENSOR\_CONFIG1  
Address: 0x21

| Bit   | Access | Default | Description                    |
|-------|--------|---------|--------------------------------|
| [7:0] | RW     |         | Low 8 bits of room temperature |

Name:TEMP\_SENSOR\_CONFIG2  
Address: 0xD5

| Bit   | Access | Default | Description  |
|-------|--------|---------|--|
| [7:3] |        |         | Reserved   |
| [2]   | RW     | 1       | Temp Sensor Enable (Analog). 0: Enable; 1: Disable |
| [1:0] |        |         | Reserved   |

### 7.1.9 Register 0x22 - 0x26: Accelerometer Configuration

Name:ACC\_CONFIG\_0  
Address: 0x22

| Bit   | Access | Default | Description                                      |
|-------|--------|---------|--|
| 7     | RW     | 0       | Acc work mode. 1: Low power mode; 0: Normal mode |
| 6     | RW     | 0       | Acc ADC dither enable. 1: Enable, 0: Disable     |
| [5:1] |        |         | Reserved   |
| 0     | RW     | 1       | Acc digital filter enable. 1: Enable; 0: Disable |

Name:ACC\_CONFIG\_1  
Address: 0x23

| Bit   | Access | Default | Description   |
|-------|--------|---------|---|
| [7:4] |        |         | Reserved  |
| [3:0] | RW     | 0000    | Acc ODR configuration. 0000: 1000Hz; 0001: 500Hz; 0010: 250Hz; 0011: 125Hz; 0100: 63Hz; 0101: 31Hz; 0110: 16Hz; 1000: 2000Hz; 1001: 4000Hz 1010: 8000Hz |



Name: ACC\_CONFIG\_2

Address: 0x25

| Bit   | Access | Default | Description   |
|-------|--------|---------|---|
| [7:3] |        |         | Reserved  |
| [2:0] | RW     | 010     | Acc range configuration. 010: $\pm 16g$ ; 011: $\pm 8g$ ; 100: $\pm 4g$ ; 101: $\pm 2g$ |

Name: ACC\_CONFIG\_3

Address: 0x26

| Bit   | Access | Default | Description   |
|-------|--------|---------|---|
| [7:5] | RW     | 001     | Acc low pass filter cut-off frequency configuration, 000: $ODR \times 0.40$ ; 001: $ODR \times 0.25$ ; 010: $ODR \times 0.11$ ; 011: $ODR \times 0.04$ ; 100: $ODR \times 0.02$ |
| 4     |        |         | Reserved  |
| 3     | RW     | 0       | Whether bypass acc low pass filter, 1: Yes; 0: No   |
| [2:0] |        |         | Reserved  |

### 7.1.10 Register 0x28 - 0x2B & 0x8F & 0x9F & 0xAF: Gyroscope Configuration

Name: GYRO\_CONFIG\_0

Address: 0x28

| Bit   | Access | Default | Description   |
|-------|--------|---------|---|
| [7:5] |        |         | Reserved  |
| 4     | RW     | 0       | Whether shut down gyroscope as Inactivity Interrupt detected. 1: Yes; 0: No |
| [3:1] |        |         | Reserved  |
| 0     | RW     | 1       | Gyroscope digital filter enable. 1:Enable; 0:Disable                        |

Name: GYRO\_CONFIG\_1

Address: 0x29

| Bit   | Access | Default | Description  |
|-------|--------|---------|--|
| [7:4] |        |         | Reserved   |
| [3:0] | RW     | 0000    | Gyroscope ODR. 0000: 1000Hz; 0001: 500Hz; 0010: 250Hz; 0011: 125Hz; 0100: 63Hz; 0101: 31Hz; 1000: 2kHz; 1001: 4kHz; 1010: 8kHz; 1011: 16kHz; 1100: 32kHz |

Name: GYRO\_CONFIG\_2

Address: 0x2B

| Bit   | Access | Default | Description  |
|-------|--------|---------|--|
| [7:5] |        |         | Reserved   |
| 4     | RW     | 0       | Gyroscope digital LPF bypass enable. 1: Enable; 0: Disable               |
| [3:2] | RW     | 00      | Gyroscope digital LPF cut-off frequency configuration, refer to Table 14 |
| [1:0] |        |         | Reserved   |

Table 14: Gyroscope digital LPF cut-off frequency configuration (unit: Hz)

| ODR (Hz)<br>0x2B[3:2] | 32k  | 16k  | 8k   | 4k   | 1000 | 500 | 250 | 125 | 63 | 31 |
|-----------------------|------|------|------|------|------|-----|-----|-----|----|----|
| 00                    | 2000 | 1600 | 1313 | 1138 | 363  | 181 | 90  | 45  | 23 | 11 |
| 01                    | 1525 | 1000 | 438  | 438  | 320  | 160 | 80  | 40  | 20 | 10 |
| 10                    | 1138 | 638  | 313  | 313  | 250  | 125 | 63  | 31  | 15 | 8  |
| 11                    | 863  | 438  | 213  | 219  | 200  | 100 | 50  | 25  | 13 | 6  |

Name: GYRO\_CONFIG\_3

Address: 0x8F

| Bit   | Access | Default | Description  |
|-------|--------|---------|--|
| [7:3] |        |         | Reserved   |
| [2:0] | RW     | 110     | Gyroscope X-axis full scale range. 010: 125dps; 011: 250dps; 100: 500dps; 101: 1000dps; 110: 2000dps |

Name: GYRO\_CONFIG\_4

Address: 0x9F

| Bit   | Access | Default | Description  |
|-------|--------|---------|--|
| [7:3] |        |         | Reserved   |
| [2:0] | RW     | 110     | Gyroscope Y-axis full scale range. 010: 125dps; 011: 250dps; 100: 500dps; 101: 1000dps; 110: 2000dps |

Name: GYRO\_CONFIG\_5

Address: 0xAF

| Bit   | Access | Default | Description  |
|-------|--------|---------|--|
| [7:3] |        |         | Reserved   |
| [2:0] | RW     | 110     | Gyroscope Z-axis full scale range. 010: 125dps; 011: 250dps; 100: 500dps; 101: 1000dps; 110: 2000dps |

### 7.1.11 Register 0x32: SPI Configuration

Name: SPI\_CONFIG

Address: 0x32

| Bit   | Access | Default | Description   |
|-------|--------|---------|---|
| [7:1] |        |         | Reserved  |
| 0     | RW     | 0       | SPI work mode configuration. 1: 3-wire mode; 0: 4-wire mode |

### 7.1.12 Register 0x35 - 0x39: FIFO Configuration

Name: FIFO\_CONFIG\_0

Address: 0x35

| Bit   | Access | Default | Description   |
|-------|--------|---------|---|
| 7     | RW     | 0       | 1: Reset FIFO controller; 0: Normal operation mode                              |
| [6:2] |        |         | Reserved  |
| [1:0] | RW     | 00      | FIFO mode select. 00: Disable; 01: FIFO Mode; 10: Stream Mode; 11: Trigger Mode |

Name: FIFO\_CONFIG\_1

Address: 0x36

| Bit   | Access | Default  | Description                         |
|-------|--------|----------|-------------------------------------|
| [7:0] | RW     | 00000000 | FIFO watermark level setup bit[7:0] |

Name: FIFO\_CONFIG\_2

Address: 0x37

| Bit   | Access | Default | Description  |
|-------|--------|---------|--|
| [7:6] |        |         | Reserved   |
| 5     | RW     | 0       | Whether external sensor Z data is in FIFO. 1: Yes; 0: No |
| 4     | RW     | 0       | Whether external sensor Y data is in FIFO. 1: Yes; 0: No |
| 3     |        |         | Reserved   |
| [2:0] | RW     | 000     | FIFO watermark level setup bit[10:8]                     |

Name: FIFO\_CONFIG\_3  
Address: 0x38

| Bit | Access | Default | Description   |
|-----|--------|---------|---|
| 7   | RW     | 0       | Whether external sensor X data is in FIFO. 1: Yes; 0: No    |
| 6   | RW     | 0       | Whether temperature sensor data is in FIFO. 1: Yes; 0: No   |
| 5   | RW     | 0       | Whether gyroscope Z axis data is in FIFO. 1: Yes; 0: No     |
| 4   | RW     | 0       | Whether gyroscope Y axis data is in FIFO. 1: Yes; 0: No     |
| 3   | RW     | 0       | Whether gyroscope X axis data is in FIFO. 1: Yes; 0: No     |
| 2   | RW     | 0       | Whether accelerometer Z axis data is in FIFO. 1: Yes; 0: No |
| 1   | RW     | 0       | Whether accelerometer Y axis data is in FIFO. 1: Yes; 0: No |
| 0   | RW     | 0       | Whether accelerometer X axis data is in FIFO. 1: Yes; 0: No |

Name: FIFO\_CONFIG\_4  
Address: 0x39

| Bit   | Access | Default | Description  |
|-------|--------|---------|--|
| 7     | RW     | 0       | Accel data down sample for FIFO enable. 1: Enable; 0: Disable  |
| [6:4] | RW     | 000     | Accel data down sample ratio to ODR. 000: 1/2; 001: 1/4; 010: 1/8; 011: 1/16; 100: 1/32; 101: 1/64; 110: 1/128; 111: 1/256 |
| 3     | RW     | 0       | Gyro data down sample for FIFO enable. 1: Enable; 0: Disable   |
| [2:0] | RW     | 000     | Gyro data down sample ratio to ODR. 000: 1/2; 001: 1/4; 010: 1/8; 011: 1/16; 100: 1/32; 101: 1/64; 110: 1/128; 111: 1/256  |

### 7.1.13 Register 0x3A - 0x3B: Master I<sup>2</sup>C Configuration

Name: MI<sup>2</sup>C\_CONFIG\_0  
Address: 0x3A

| Bit   | Access | Default | Description  |
|-------|--------|---------|--|
| 7     | RW     | 0       | 1: Master I <sup>2</sup> C reset; 0: Master I <sup>2</sup> C normal operation  |
| 6     | RW     | 0       | Master I <sup>2</sup> C read mode. 1: Auto; 0: Manual  |
| 5     | RO     | 0       | Master I <sup>2</sup> C failure flag   |
| 4     | RO     | 0       | Master I <sup>2</sup> C success flag   |
| [3:2] |        |         | Reserved   |
| 1     | RW     | 0       | 1: Master I <sup>2</sup> C enabled, auto clear after master I <sup>2</sup> C operation is done; 0: Master I <sup>2</sup> C is idle |
| 0     | RW     | 0       | 1: Master I <sup>2</sup> C read operation; 0: Master I <sup>2</sup> C write operation  |

Name: MI<sup>2</sup>C\_CONFIG\_1  
Address: 0x3B

| Bit   | Access | Default | Description  |
|-------|--------|---------|--|
| [7:6] |        |         | Reserved   |
| [5:4] | RW     | 00      | Master I <sup>2</sup> C read mode ODR. 00: 200Hz; 01: 100Hz; 10: 50Hz; 11: 25Hz  |
| [3:0] | RW     | 0000    | Master I <sup>2</sup> C operation frequency selection. N is the decimal value of [3:0], 1MHz/(6+3×N) is the operation frequency. |

#### 7.1.14 Register 0x3C - 0x3D: Master I<sup>2</sup>C Command

Name: MI<sup>2</sup>C\_COMM\_0  
Address: 0x3C

| Bit   | Access | Default | Description                    |
|-------|--------|---------|--------------------------------|
| [7:1] | RW     | 0000000 | Slave I <sup>2</sup> C address |
| 0     |        |         | Reserved                       |

Name: MI<sup>2</sup>C\_COMM\_1  
Address: 0x3D

| Bit   | Access | Default  | Description                             |
|-------|--------|----------|---|
| [7:0] | RW     | 00000000 | Command send to I <sup>2</sup> C device |

#### 7.1.15 Register 0x3E: Master I<sup>2</sup>C Write Data

Name: MI<sup>2</sup>C\_WRT\_DATA  
Address: 0x3E

| Bit   | Access | Default  | Description                           |
|-------|--------|----------|---------------------------------------|
| [7:0] | RW     | 00000000 | Data write to I <sup>2</sup> C device |

#### 7.1.16 Register 0x3F: Master I<sup>2</sup>C Read Out Data

Name: MI<sup>2</sup>C\_RAD\_DATA  
Address: 0x3F

| Bit   | Access | Default  | Description                                |
|-------|--------|----------|--|
| [7:0] | RO     | 00000000 | Data read out from I <sup>2</sup> C device |

### 7.1.17 Register 0x40 - 0x41: Interrupt Enable

Name: INTERRUPT\_EN\_0  
Address: 0x40

| Bit | Access | Default | Description   |
|-----|--------|---------|---|
| 7   | RW     | 0       | Low-G Interrupt enable. 1: Enable; 0: Disable       |
| 6   | RW     | 0       | High-G Interrupt enable. 1: Enable; 0: Disable      |
| 5   | RW     | 0       | Inactivity Interrupt enable. 1: Enable; 0: Disable  |
| 4   | RW     | 0       | Activity Interrupt enable. 1: Enable; 0: Disable    |
| 3   | RW     | 0       | Double Tap Interrupt enable. 1: Enable; 0: Disable  |
| 2   | RW     | 0       | Tap Interrupt enable. 1: Enable; 0: Disable         |
| 1   | RW     | 0       | Flat Interrupt enable. 1: Enable; 0: Disable        |
| 0   | RW     | 0       | Orientation Interrupt enable. 1: Enable; 0: Disable |

Name: INTERRUPT\_EN\_0  
Address: 0x41

| Bit   | Access | Default | Description  |
|-------|--------|---------|--|
| [7:5] |        |         | Reserved   |
| 4     | RW     | 0       | FIFO Gyroscope Watermark Interrupt enable. 1: Enable; 0: Disable     |
| 3     | RW     | 0       | Gyroscope Data Ready Interrupt enable. 1: Enable; 0: Disable         |
| 2     | RW     | 0       | FIFO Accelerometer Watermark Interrupt enable. 1: Enable; 0: Disable |
| 1     | RW     | 0       | Accelerometer Data Ready Interrupt enable. 1: Enable; 0: Disable     |
| 0     | RW     | 0       | Free-fall Interrupt enable. 1: Enable; 0: Disable                    |

### 7.1.18 Register 0x44: Interrupt Configuration

Name: INTERRUPT\_CONFIG  
Address: 0x44

| Bit | Access | Default | Description   |
|-----|--------|---------|---|
| 7   | RW     | 0       | Interrupt output pin INT active level. 1: Low; 0: High  |
| 6   | RW     | 0       | 1: Interrupt is not latched and will be auto clear after defined period of time; 0: Interrupt is latched and will be clear after read interrupt status register |
| 5   |        |         | Interrupt output pin INT1 active level. 1: Low; 0: High   |
| 4   | RW     | 0       | Interrupt flag clear mode. 1: Clear interrupt status by any register read operation; 0: Clear interrupt status by reading the interrupt status register         |
| 3   |        |         | Reserved  |
| 2   | RW     | 1       | Interrupt output pin INT1 mode. 1: Normal output; 0: Open-drain output  |
| 1   |        |         | Reserved  |
| 0   | RW     | 1       | Interrupt output pin INT mode. 1: Normal output; 0: Open-drain output   |

### 7.1.19 Register 0x45: Interrupt Count Limit

Name: INTERRUPT\_CONT\_LIM  
Address: 0x45

| Bit   | Access | Default  | Description   |
|-------|--------|----------|---|
| [7:0] | RW     | 00000000 | If interrupt is not latched set by register 0x44[6], interrupt pin will be auto cleared when interrupt last time is longer than the time define in this register. This counter is based on 512Hz clock. |

### 7.1.20 Register 0x46 - 0x4D: Orientation Interrupt Configuration

Name: ORIENT\_INT\_CONFIG\_0  
Address: 0x46

| Bit   | Access | Default | Description   |
|-------|--------|---------|---|
| 7     |        |         | Reserved  |
| 6     | RW     | 0       | Up-down Orientation Interrupt Enable. 1: Enable; 0: Disable |
| [5:0] | RW     | 000000  | $\tan^2\theta$ for Orientation Interrupt                    |

Name: ORIENT\_INT\_CONFIG\_1  
Address: 0x47

| Bit   | Access | Default | Description  |
|-------|--------|---------|--|
| [7:4] |        |         | Reserved   |
| [3:2] | RW     | 00      | Orientation interrupt blocking mode. 00: No blocking; 01: $\theta$ blocking or acceleration in any axis $> 1.5g$ ; 10: $\theta$ blocking or acceleration slope in any axis $> 0.2g$ or acceleration in any axis $> 1.5g$ ; 11: $\theta$ blocking or acceleration slope in any axis $> 0.4g$ or acceleration in any axis $> 1.5g$ and value of orient is not stable for at least 100ms. |
| [1:0] | RW     | 00      | Orientation mode. 00/11: Symmetrical; 01: High-asymmetrical; 10: Low-asymmetrical  |

Name: ORIENT\_INT\_CONFIG\_2

Address: 0x48

| Bit   | Access | Default  | Description   |
|-------|--------|----------|---|
| [7:0] | RW     | 00000000 | Low byte of the 1.5g value for orientation blocking |

Name: ORIENT\_INT\_CONFIG\_3

Address: 0x49

| Bit   | Access | Default  | Description  |
|-------|--------|----------|--|
| [7:0] | RW     | 00000000 | High byte of the 1.5g value for orientation blocking |

Name: ORIENT\_INT\_CONFIG\_4

Address: 0x4A

| Bit   | Access | Default  | Description  |
|-------|--------|----------|--|
| [7:0] | RW     | 00000000 | Low byte of the slope value for orientation blocking |

Name: ORIENT\_INT\_CONFIG\_5

Address: 0x4B

| Bit   | Access | Default  | Description   |
|-------|--------|----------|---|
| [7:0] | RW     | 00000000 | High byte of the slope value for orientation blocking |

Name: ORIENT\_INT\_CONFIG\_6

Address: 0x4C

| Bit   | Access | Default  | Description   |
|-------|--------|----------|---|
| [7:0] | RW     | 00000000 | Low byte of hysteresis value for orientation blocking |



Name: ORIENT\_INT\_CONFIG\_7  
Address: 0x4D

| Bit   | Access | Default  | Description  |
|-------|--------|----------|--|
| [7:0] | RW     | 00000000 | High byte of hysteresis value for orientation blocking |

### 7.1.21 Register 0x4E: Flat Interrupt Configuration

Name: FLAT\_INT\_CONFIG  
Address: 0x4E

| Bit   | Access | Default | Description   |
|-------|--------|---------|---|
| [7:6] | RW     | 01      | Flat time threshold. 01: 500; 10: 1000; 11: 2000. The unit is <i>ms</i> . |
| [5:0] | RW     | 000000  | $\tan^2\theta$ for Flat Interrupt   |

### 7.1.22 Register 0x4F - 0x50 & 0x55 - 0x58 & 0x7B - 0x7E: Activity & Inactivity Interrupt Configuration

Name: ACT\_INACT\_CONFIG\_0  
Address: 0x4F

| Bit | Access | Default | Description   |
|-----|--------|---------|---|
| 7   | RW     | 0       | Activity Interrupt Mode. 1: AC Mode; 0: DC Mode           |
| 6   | RW     | 0       | X-axis Activity Interrupt enable. 1: Enable; 0: Disable   |
| 5   | RW     | 0       | Y-axis Activity Interrupt enable. 1: Enable; 0: Disable   |
| 4   | RW     | 0       | Z-axis Activity Interrupt enable. 1: Enable; 0: Disable   |
| 3   | RW     | 0       | Inactivity Interrupt Mode. 1: AC Mode; 0: DC Mode         |
| 2   | RW     | 0       | X-axis Inactivity Interrupt enable. 1: Enable; 0: Disable |
| 1   | RW     | 0       | Y-axis Inactivity Interrupt enable. 1: Enable; 0: Disable |
| 0   | RW     | 0       | Z-axis Inactivity Interrupt enable. 1: Enable; 0: Disable |

Name: TAP\_ACT\_INACT\_CONFIG  
Address: 0x50

| Bit   | Access | Default | Description  |
|-------|--------|---------|--|
| [7:4] |        |         | Reserved   |
| 3     | RW     | 0       | X-axis Tap Interrupt enable. 1: Enable; 0: Disable   |
| 2     | RW     | 0       | Y-axis Tap Interrupt enable. 1: Enable; 0: Disable   |
| 1     | RW     | 0       | Z-axis Tap Interrupt enable. 1: Enable; 0: Disable   |
| 0     | RW     | 0       | Link Activity/Inactivity status. 1: If the previous status is activity, only Inactivity Interrupt can be generated. If the previous status is inactivity, only Activity Interrupt can be generated; 0: Activity/Inactivity will trigger interrupt no matter what previous status is. |

Name: ACT\_INT\_THR

Address: 0x55

| Bit   | Access | Default  | Description  |
|-------|--------|----------|--|
| [7:0] | RW     | 00000000 | Threshold for Activity Interrupt. Absolute value is used in DC mode, and the delta value of two consecutive samples is used in AC mode. The threshold is range dependent and the value defined by 1 LSB is 0.24mg, 0.48mg, 0.97mg and 1.95mg as the range is set to $\pm 2g$ , $\pm 4g$ , $\pm 8g$ and $\pm 16g$ , respectively. |

Name: ACT\_INT\_TIME

Address: 0x56

| Bit   | Access | Default  | Description  |
|-------|--------|----------|--|
| [7:0] | RW     | 00000000 | The number of consecutive samples that acceleration must be greater than the value defined by register 0x55 for Activity Interrupt to be declared. |

Name: INACT\_INT\_THR\_L

Address: 0x57

| Bit   | Access | Default  | Description                                 |
|-------|--------|----------|---|
| [7:0] | RW     | 00000000 | Low byte of Inactivity Interrupt threshold. |

Name: INACT\_INT\_TIME

Address: 0x58

| Bit   | Access | Default  | Description   |
|-------|--------|----------|---|
| [7:0] | RW     | 00000000 | The amount of time that acceleration must be less than the value in the inactivity threshold register for Inactivity Interrupt to be declared. The unit is s. |

Name: INACT\_INT\_THR\_M  
Address: 0x7B

| Bit   | Access | Default  | Description                                   |
|-------|--------|----------|---|
| [7:0] | RW     | 00000000 | Middle byte of Inactivity Interrupt threshold |

Name: INACT\_INT\_THR\_H  
Address: 0x7C

| Bit   | Access | Default  | Description                                 |
|-------|--------|----------|---|
| [7:0] | RW     | 00000000 | High byte of Inactivity Interrupt threshold |

Name: INACT\_INT\_1G\_L  
Address: 0x7D

| Bit   | Access | Default  | Description                                   |
|-------|--------|----------|---|
| [7:0] | RW     | 00000000 | Low byte of 1G value for Inactivity Interrupt |

Name: INACT\_INT\_1G\_H  
Address: 0x7E

| Bit   | Access | Default  | Description                                    |
|-------|--------|----------|--|
| [7:0] | RW     | 00000000 | High byte of 1G value for Inactivity Interrupt |

### 7.1.23 Register 0x50 - 0x54: Tap Interrupt Configuration

Name: TAP\_ACT\_INACT\_CONFIG  
Address: 0x50

| Bit   | Access | Default | Description  |
|-------|--------|---------|--|
| [7:4] |        |         | Reserved   |
| 3     | RW     | 0       | X-axis Tap Interrupt enable. 1: Enable; 0: Disable   |
| 2     | RW     | 0       | Y-axis Tap Interrupt enable. 1: Enable; 0: Disable   |
| 1     | RW     | 0       | Z-axis Tap Interrupt enable. 1: Enable; 0: Disable   |
| 0     | RW     | 0       | Link Activity/Inactivity status. 1: If the previous status is activity, only Inactivity Interrupt can be generated. If the previous status is inactivity, only Activity Interrupt can be generated; 0: Activity/Inactivity will trigger interrupt no matter what previous status is. |

Name: TAP\_INT\_THR  
Address: 0x51

| Bit   | Access | Default  | Description                              |
|-------|--------|----------|--|
| [7:0] | RW     | 00000000 | Acceleration threshold for TAP Interrupt |

Name: TAP\_INT\_DUR  
Address: 0x52

| Bit   | Access | Default  | Description   |
|-------|--------|----------|---|
| [7:0] | RW     | 00000000 | Time threshold for TAP Interrupt. The unit is <i>ms</i> . |

Name: TAP\_INT\_LAT  
Address: 0x53

| Bit   | Access | Default  | Description   |
|-------|--------|----------|---|
| [7:0] | RW     | 00000000 | The wait time from the detection of a tap event to the start of the time window during which a possible second tap event can be detected. The unit is <i>ms</i> . |

Name: DOUBLETAP\_INT\_WIN  
Address: 0x54

| Bit   | Access | Default  | Description   |
|-------|--------|----------|---|
| [7:0] | RW     | 00000000 | The amount of time after the expiration of the latency time during which a second valid tap can be begin. The unit is <i>ms</i> . |

### 7.1.24 Register 0x59 - 0x5D: High-G & Low-G Interrupt Configuration

Name: H&L-G\_INT\_CONFIG\_0  
Address: 0x59

| Bit   | Access | Default | Description  |
|-------|--------|---------|--|
| 7     | RW     | 0       | High-G Interrupt of all axes enable. 1: Enable; 0: Disable |
| 6     | RW     | 0       | High-G Interrupt of X-axis enable. 1: Enable; 0: Disable   |
| 5     | RW     | 0       | High-G Interrupt of Y-axis enable. 1: Enable; 0: Disable   |
| 4     | RW     | 0       | High-G Interrupt of Z-axis enable. 1: Enable; 0: Disable   |
| [3:1] |        |         | Reserved   |
| 0     | RW     | 0       | Low-G Interrupt of all axes enable. 1: Enable; 0: Disable  |

Name: HIGH-G\_INT\_THR  
Address: 0x5A

| Bit   | Access | Default  | Description  |
|-------|--------|----------|--|
| [7:0] | RW     | 00000000 | The acceleration threshold of High-G Interrupt. 1 LSB equals to 0.5mg, 1mg, 2mg and 4mg as the range is $\pm 2g$ , $\pm 4g$ , $\pm 8g$ and $\pm 16g$ respectively. |

Name: HIGH-G\_INT\_TIME  
Address: 0x5B

| Bit   | Access | Default  | Description   |
|-------|--------|----------|---|
| [7:0] | RW     | 00000000 | Minimum time that the acceleration value of all axes must be greater than the value set by 0x5A to generate a High-G Interrupt. The counter is based on 512 Hz clock. |

Name: LOW-G\_INT\_THR  
Address: 0x5C

| Bit   | Access | Default  | Description   |
|-------|--------|----------|---|
| [7:0] | RW     | 00000000 | The acceleration threshold of Low-G Interrupt. 1 LSB equals to 0.5mg, 1mg, 2mg and 4mg as the range is $\pm 2g$ , $\pm 4g$ , $\pm 8g$ and $\pm 16g$ respectively. |

Name: LOW-G\_INT\_TIME  
Address: 0x5D

| Bit   | Access | Default  | Description  |
|-------|--------|----------|--|
| [7:0] | RW     | 00000000 | Minimum time that the acceleration value of all axes must be smaller than the value set by 0x5C to generate a Low-G Interrupt. The counter is based on 512 Hz clock. |

### 7.1.25 Register 0x5E - 0x5F: Free Fall Interrupt Configuration

Name: FREE-FALL\_INT\_THR  
Address: 0x5E

| Bit   | Access | Default  | Description   |
|-------|--------|----------|---|
| [7:0] | RW     | 00000000 | The acceleration threshold of Free-fall Interrupt. 1 LSB equals to 0.5mg, 1mg, 2mg and 4mg as the range is $\pm 2g$ , $\pm 4g$ , $\pm 8g$ and $\pm 16g$ respectively. |

Name: FREE-FALL\_INT\_TIME

Address: 0x5F

| Bit   | Access | Default  | Description  |
|-------|--------|----------|--|
| [7:0] | RW     | 00000000 | Minimum time that the acceleration value of all axes must be smaller than the value set by 0x5E to generate a Free-Fall Interrupt. The counter is based on 512 Hz clock. |

### 7.1.26 Register 0x79 - 0x7A: Interrupt Pin Mapping

Name: INT\_PINMP\_0

Address: 0x79

| Bit | Access | Default | Description  |
|-----|--------|---------|--|
| 7   | RW     | 0       | High-G Interrupt pin mapping. 1: INT1; 0: INT      |
| 6   | RW     | 0       | Inactivity Interrupt pin mapping. 1: INT1; 0: INT  |
| 5   | RW     | 0       | Activity Interrupt pin mapping. 1: INT1; 0: INT    |
| 4   | RW     | 0       | Double and Single Tap pin mapping 1: INT1; 0: INT  |
| 3   | RW     | 0       | Double Tap Interrupt pin mapping. 1: INT1; 0: INT  |
| 2   | RW     | 0       | Single Tap Interrupt pin mapping. 1: INT1; 0: INT  |
| 1   | RW     | 0       | Flat Interrupt pin mapping. 1: INT1; 0: INT        |
| 0   | RW     | 0       | Orientation Interrupt pin mapping. 1: INT1; 0: INT |

Name: INT\_PINMP\_1

Address: 0x7A

| Bit   | Access | Default | Description   |
|-------|--------|---------|---|
| [7:6] |        |         | Reserved  |
| 5     | RW     | 0       | Gyroscope FIFO Watermark Interrupt pin mapping. 1: INT1; 0: INT     |
| 4     | RW     | 0       | Gyroscope Data Ready Interrupt pin mapping. 1: INT1; 0: INT         |
| 3     | RW     | 0       | Accelerometer FIFO Watermark Interrupt pin mapping. 1: INT1; 0: INT |
| 2     | RW     | 0       | Accelerometer Data Ready Interrupt pin mapping. 1: INT1; 0: INT     |
| 1     | RW     | 0       | Free-fall Interrupt pin mapping. 1: INT1; 0: INT                    |
| 0     | RW     | 0       | Low-G Interrupt pin mapping. 1: INT1; 0: INT                        |

### 7.1.27 Register 0x7F: SPI Register Access

Name: SPI\_CONFIG

Address: 0x7F

| Bit   | Access | Default | Description  |
|-------|--------|---------|--|
| [7:1] |        |         | Reserved   |
| [0]   | RW     | 0       | 0: Access SPI Page1 registers; 1: Access SPI Page2 registers |

### 7.1.28 Register 0xFD: Auxiliary I<sup>2</sup>C Configuration

Name: AUX\_I<sup>2</sup>C\_CONFIG

Address: 0xFD

| Bit   | Access | Default | Description  |
|-------|--------|---------|--|
| [7:1] |        |         | Reserved   |
| [0]   | RW     | 0       | Auxiliary I <sup>2</sup> C working mode. 0: Normal Mode; 1: I <sup>2</sup> C bypass to MI <sup>2</sup> C |

## 8 Application Hints

### 8.1 Orientation of Axes

The diagram below shows the orientation of the axes of sensitivity and the polarities of rotation. Note the pin1 marker in the figure.

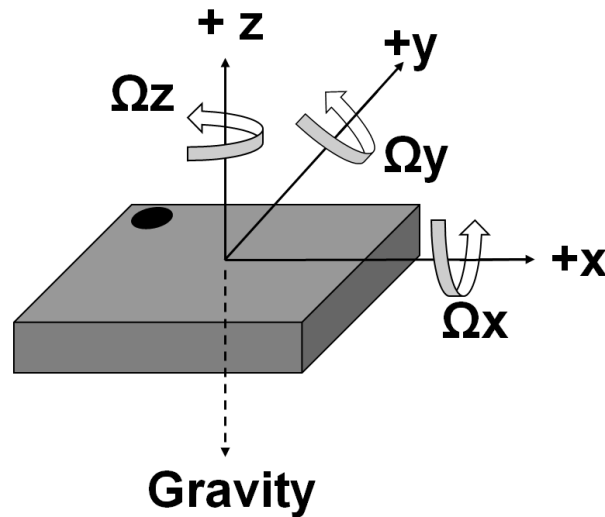

Figure 15: Orientation of axes sensitivity and polarity of rotation



## 8.2 Typical Application Circuits

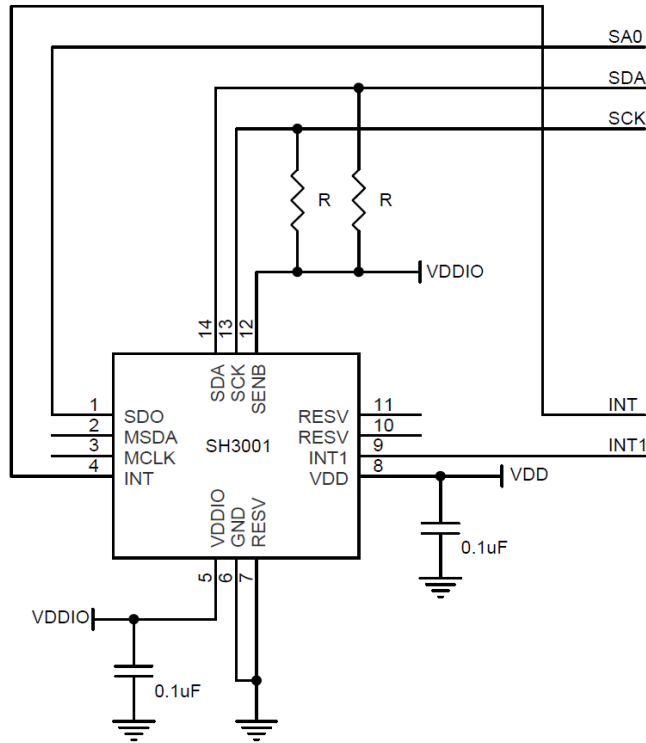

Figure 16: Reference application circuitry using only primary I<sup>2</sup>C interface

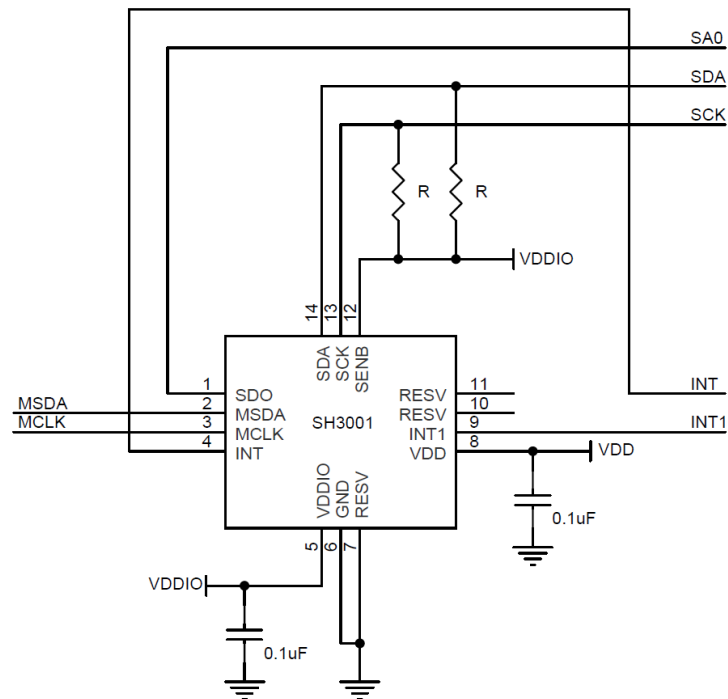

Figure 17: Reference application circuitry using primary and secondary I<sup>2</sup>C interface

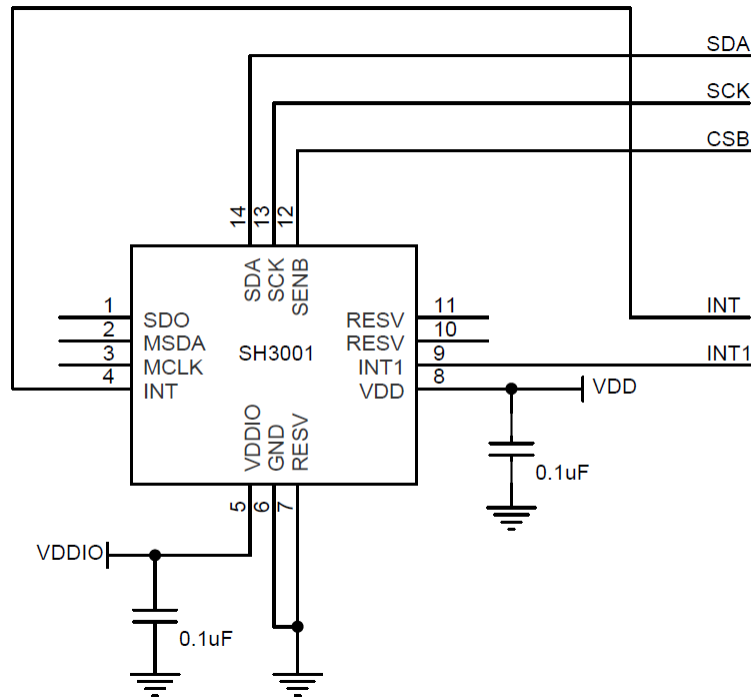

Figure 18: Reference application circuitry using SPI 3-wire interface

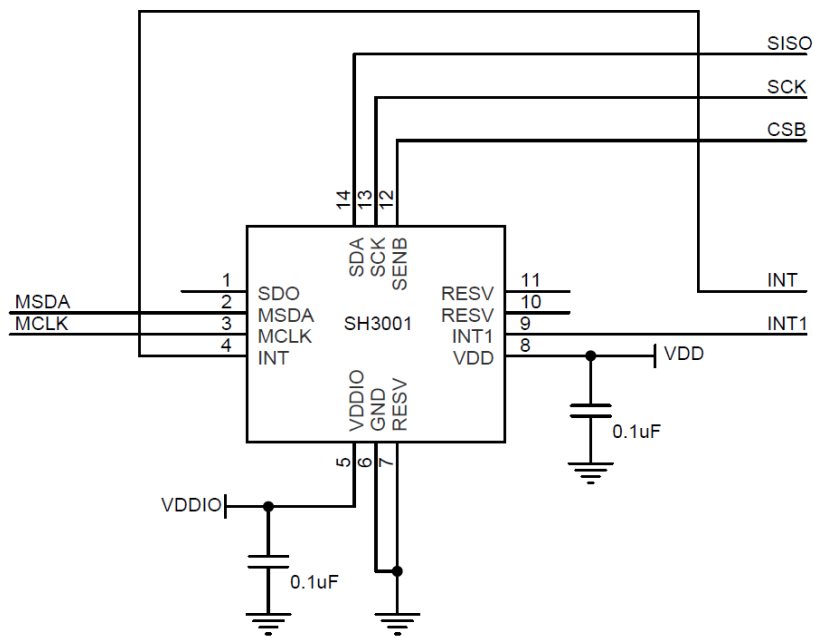

Figure 19: Reference application circuitry using SPI 3-wire and secondary I<sup>2</sup>C interface

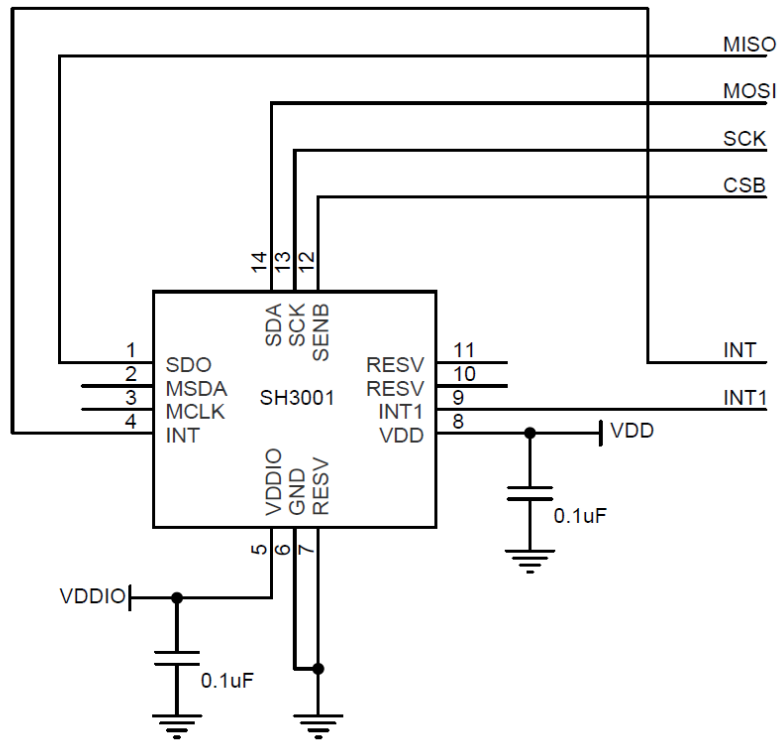

Figure 20: Reference application circuitry using SPI 4-wire interface

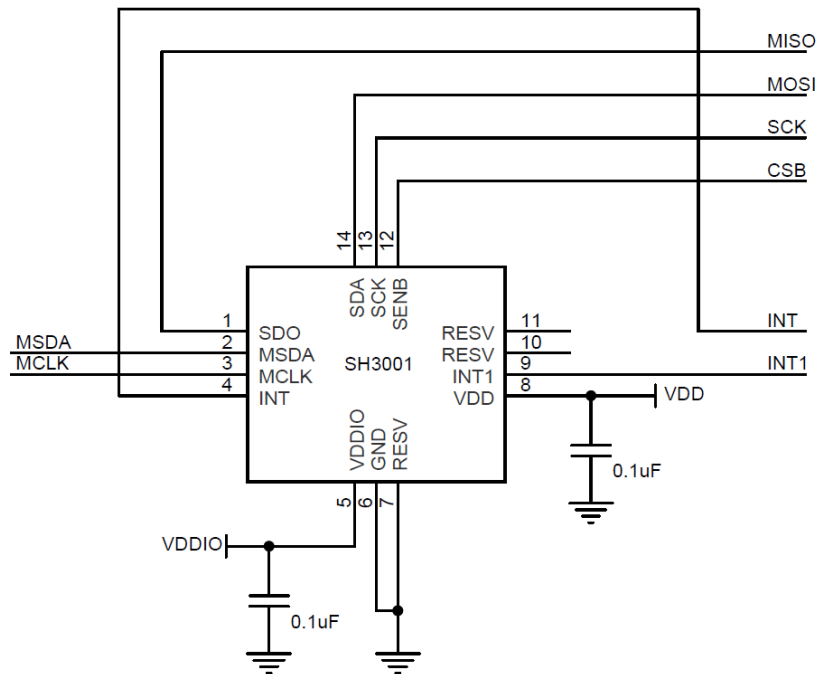

Figure 21: Reference application circuitry using SPI 4-wire and secondary I<sup>2</sup>C interface

### 8.3 Package Information

#### 8.3.1 Device Outline Dimensions

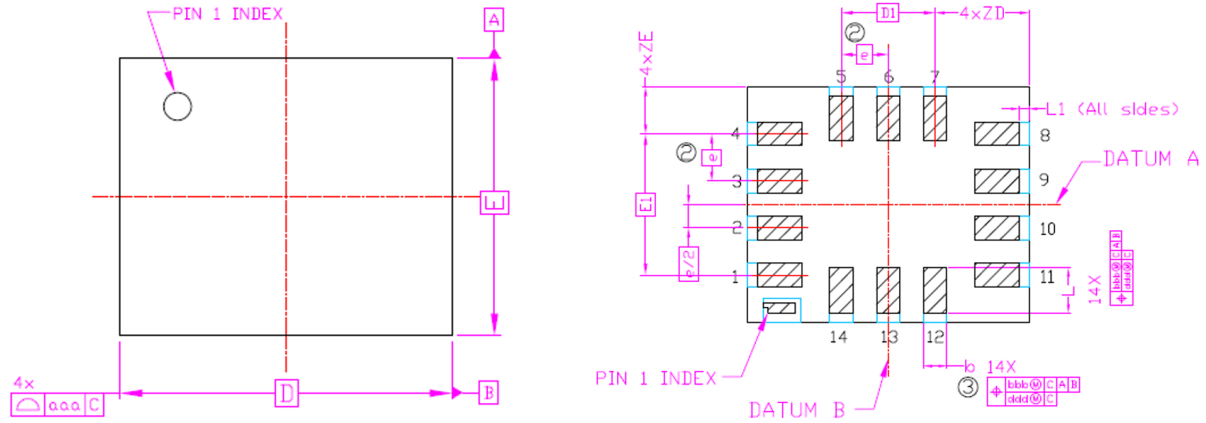

Figure 22: Top & bottom view of the device

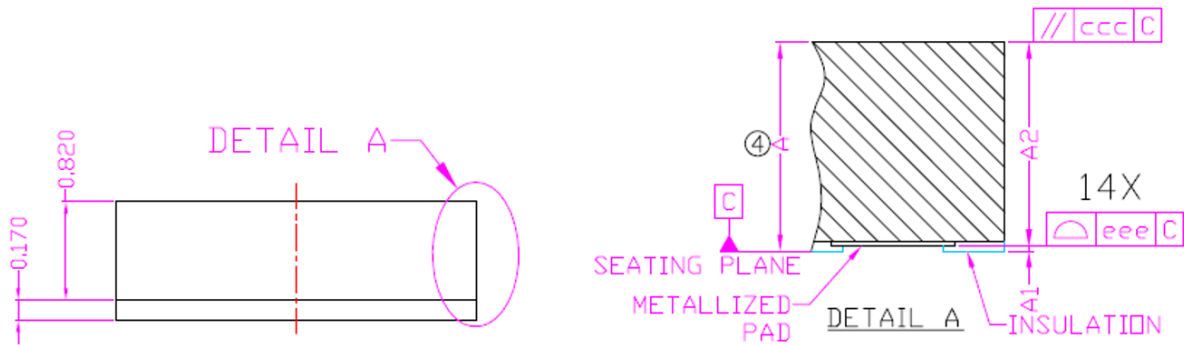

Figure 23: Side view of the device

Table 15: Dimension references (unit: mm)

| Ref | Min   | Typ   | Max   | Ref | Min      | Typ  | Max  |
|-----|-------|-------|-------|-----|----------|------|------|
| A   | 0.93  | 0.99  | 1.05  | D1  | 1.00 BSC |      |      |
| A1  |       |       | 0.03  | E1  | 1.50 BSC |      |      |
| A2  |       |       | 1.02  | ZD  | 1.00 BSC |      |      |
| b   | 0.2   | 0.25  | 0.3   | ZE  | 0.50 BSC |      |      |
| L   | 0.425 | 0.475 | 0.525 | e   | 0.50 BSC |      |      |
| D   | 2.90  | 3.00  | 3.10  | L1  | 0.00     | 0.10 | 0.20 |
| E   | 2.40  | 2.50  | 2.60  |     |          |      |      |

Note: The dimensional tolerance of aaa, bbb and ccc is 0.10 mm and that of ddd and eee is 0.08 mm.

### 8.3.2 Package Laser Mark

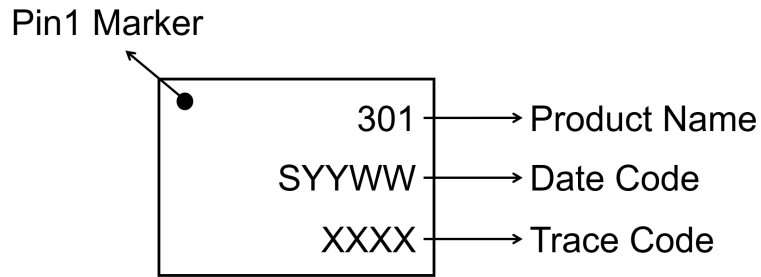

Figure 24: Package laser mark

### 8.3.3 Packaging Direction

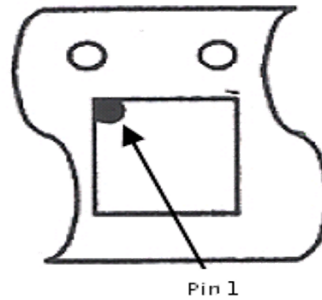

Figure 25: Packaging direction

### 8.3.4 Packaging Label

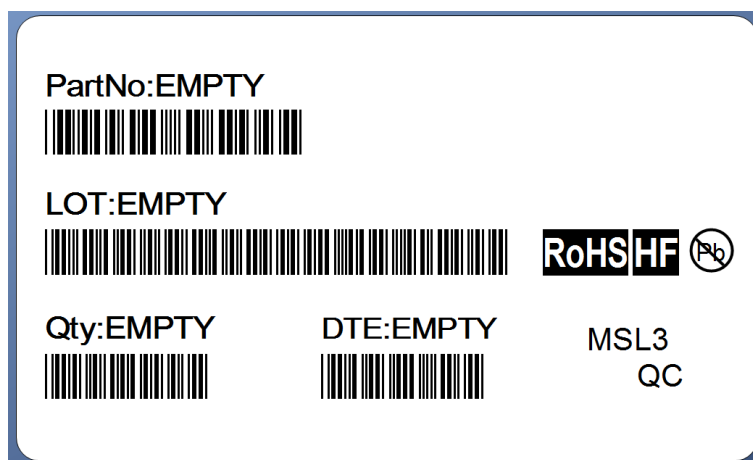

Figure 26: Packaging label example

### 8.3.5 Packaging of Product



Figure 27: Packaging of the product

### 8.4 Soldering Guidelines

The device fulfils the lead-free soldering requirements of the IPC/JEDEC J-STD-020 Pb-free standard. Reflow soldering with a peak temperature  $T_p$  of  $260^{\circ}\text{C}$ .

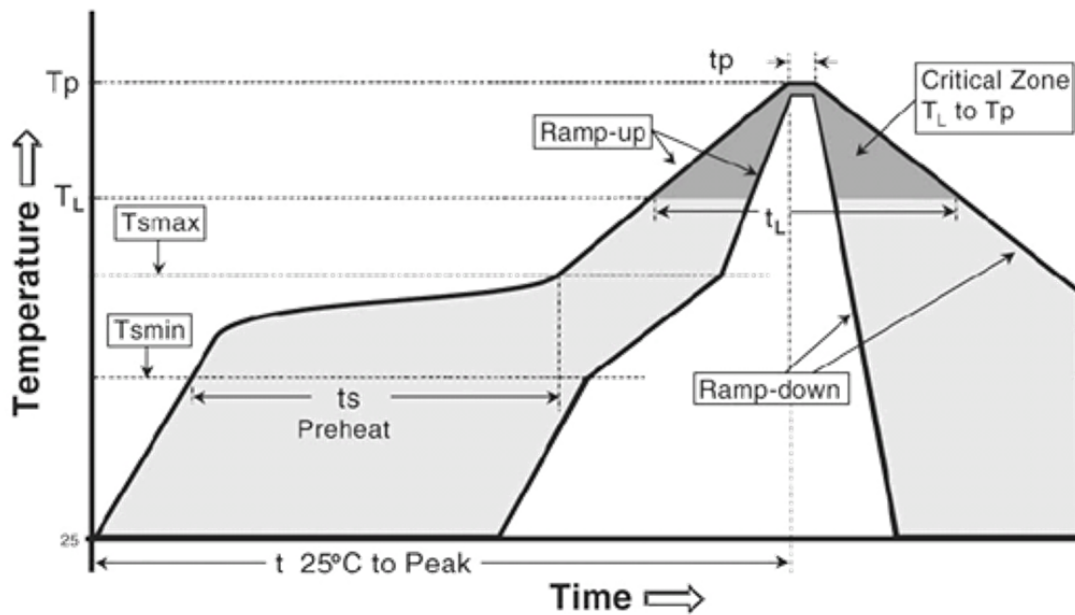

Figure 28: Recommended soldering reflow condition

Table 16: Recommended soldering reflow condition

| <b>Profile Feature</b>                          | <b>Pb-free Assembly</b> |
|---|-------------------------|
| Average ramp-up rate ( $T_{s_{max}}$ to $T_p$ ) | 3 °C/s max              |
| <b>Preheat</b>                                  |                         |
| - Temperature Min ( $T_{s_{min}}$ )             | 150 °C                  |
| - Temperature Max ( $T_{s_{max}}$ )             | 200 °C                  |
| - Time ( $T_{s_{min}}$ to $T_{s_{max}}$ ) (ts)  | 60 - 80 s               |
| Time maintained above:                          |                         |
| - Temperature ( $T_L$ )                         | 217 °C                  |
| - Time ( $t_L$ )                                | 60 - 150 s              |
| Peak Temperature ( $T_p$ )                      | 260 °C                  |
| Time within 5 °C of actual Peak Temperature     | 20 - 40 s               |
| Ramp-down rate                                  | 6 °C/s max              |
| Time 25 °C to Peak Temperature                  | 8 min max               |

## 8.5 Storage Condition

The storage condition follows JEDEC J-STD-020, MSL3.

## **9 Reliability**

### **9.1 Reliability Standard**

SH3001 reliability test plan follows JEDEC 47I standards, 'Stress-Test-Driven Qualification of Integrated Circuits'.



## **10 Environment Compliant**

SH3001 is compliant with RoHS 2.0 standards and meet HF requirements.

## **11 Disclaimer**

Information furnished by Senodia Technologies (Shaoxing) Co., Ltd. is believed to be accurate and reliable. However, Senodia reserves the right to make changes, modifications or corrections to this document and related products at any time, without notice. No license and intellectual property right is granted under this document. We reserve all rights of disposal such copying or passing on to third parties. No responsibility is assumed by Senodia for any infringements of patents or other rights of third parties which may result from its use.

## 12 Revision History

| <b>Date</b> | <b>Revision</b> | <b>Changes</b>  |
|-------------|-----------------|---|
| 2019-12-12  | 1.0             | Preliminary version                                     |
| 2020-09-16  | 1.2             | Add basic description                                   |
| 2021-03-05  | 1.3             | Update some register descriptions                       |
| 2021-05-10  | 1.5             | Update temperature sensor related register descriptions |
| 2021-09-01  | 1.6             | Update packaging information                            |
| 2023-04-06  | 1.7             | Update Power Modes information                          |