

Electrostatic Discharged Protection Devices (ESD) Data Sheet

Description

Brightking's LTS08A3.3L02 transient voltage suppressor is designed to protect components which are connected to high speed data and telecommunication lines from voltage surges caused by electrostatic discharge (ESD), electrical fast transients (EFT), and lightning.

TVS diodes are ideal for use as board level protection of sensitive semiconductor components. The LTS08A3.3L02 combines a TVS diode with a rectifier bridge to provide transient protection in both common and differential mode with a single device. The capacitance of the device is minimized (15pF) to ensure correct signal transmission on high speed lines. It meets the short-haul transient immunity requirements of Bellcore 1089 for telecommunications applications. Such as:

Bellcore 1089 (intra-building) 100A (2/20 μ s)

ITU K.20 I_{pp}=40A (5/310 μ s)

IEC61000-4-2 (ESD) 15KV (Air), 8KV (contact)

IEC61000-4-4 (EFT) 40A (5/50ns)

IEC61000-4-5 (Lightning) 100A (8/20 μ s)



Contact : $\pm 8kV$
Air : $\pm 15kV$



Features

- IEC61000-4-2 ESD 15KV Air, 8KV contact compliance
- SOIC-08 surface mount package
- Protects two high-speed data lines
- Array of surge rated, low capacitance diodes
- Low clamping voltage
- Solid-state silicon avalanche technology
- Lead Free/RoHS compliant
- Solder reflow temperature: Pure Tin-Sn, 260~270 $^{\circ}C$
- Flammability rating UL 94V-0
- Meets MSL level 1, per J-STD-020
- Marking: B LC33 or LC03-3.3

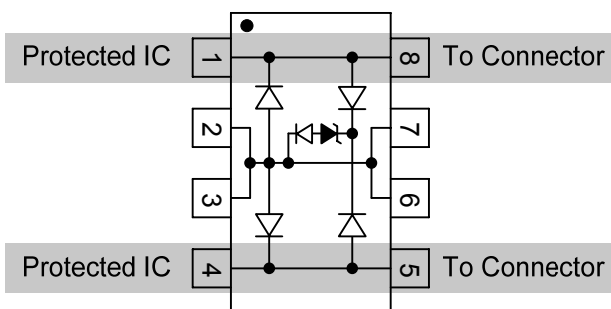
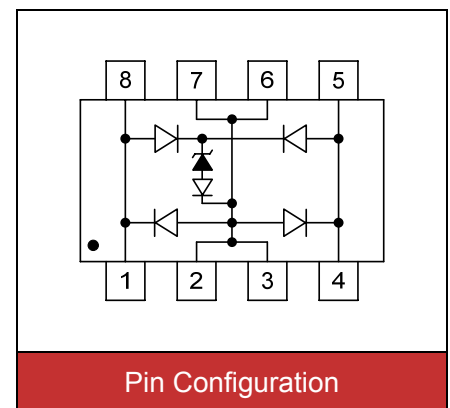

Protection --- Line to Line (Differential Mode)

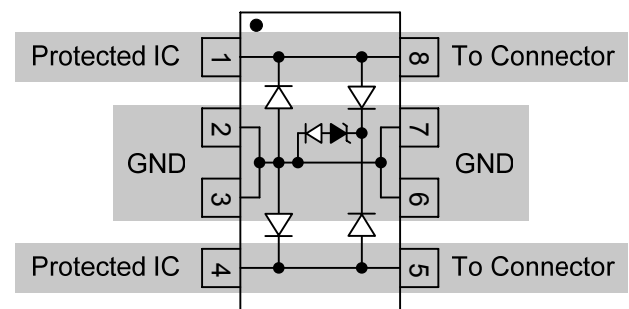

Protection --- Line to GND (Common Mode)

Maximum Ratings

Rating	Symbol	Value	Unit
Peak pulse power (tp=8/20μs waveform)	P _{PP}	2000	W
Peak pulse current (tp=8/20μs waveform)	I _{PP}	100	A
ESD voltage (Contact discharge)	V _{ESD}	±8	kV
ESD voltage (Air discharge)		±15	
Lead soldering temperature	T _L	260 (10 sec.)	°C
Storage & operating temperature range	T _{STG} , T _J	-55~+150	°C

Electrical Characteristics (T_J=25°C)

Parameter	Symbol	Condition	Min.	Typ.	Max.	Unit
Reverse stand-off voltage	V _{RWM}				3.3	V
Punch-Through voltage	V _{PT}	I _{PT} =1mA	3.5			V
Snap-Back voltage	V _{SB}	I _{SB} =50mA	2.8			V
Reverse leakage current	I _R	V _R =3.3V			15	μA
Clamping voltage (tp=8/20μs)	V _C	I _{PP} =50A Line to Ground			11.5	V
Clamping voltage (tp=8/20μs)	V _C	I _{PP} =50A Line to Line			13.5	V
Clamping voltage (tp=8/20μs)	V _C	I _{PP} =100A Line to Ground			15	V
Clamping voltage (tp=8/20μs)	V _C	I _{PP} =100A Line to Line			18	V
Off state junction capacitance (V _R =0V, f=1MHz)	C _J	Between I/O pins and GND		15	30	pF
		Between I/O pins		12	30	pF

Typical Characteristics Curves

Figure 1. Power Derating Curve

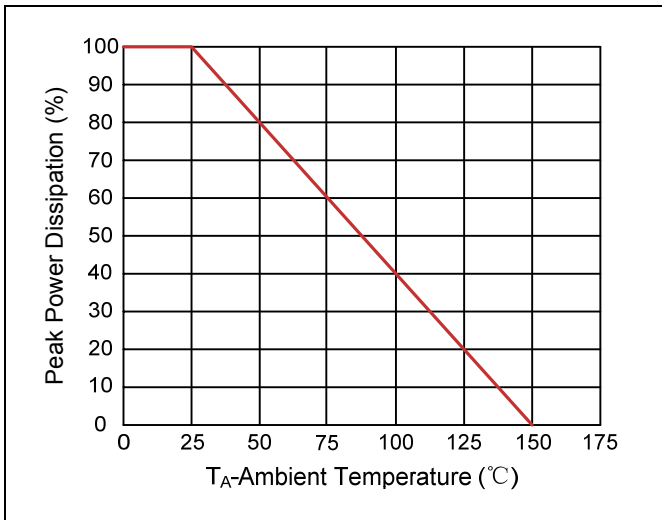

Figure 2. Pulse Waveforms

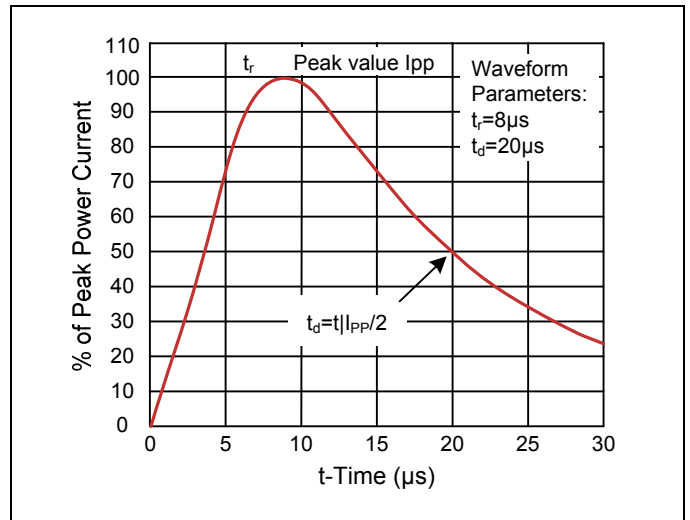

Figure 3. Non-Repetitive Peak Pulse vs. Pulse Time

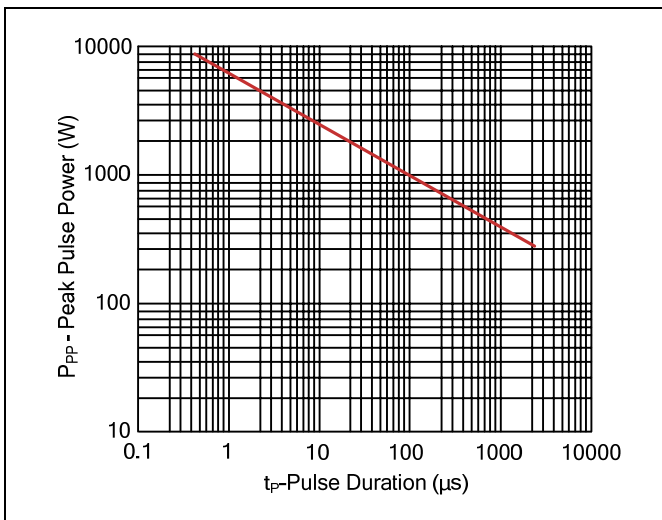

Figure 4. Capacitance vs. Reverse Voltage

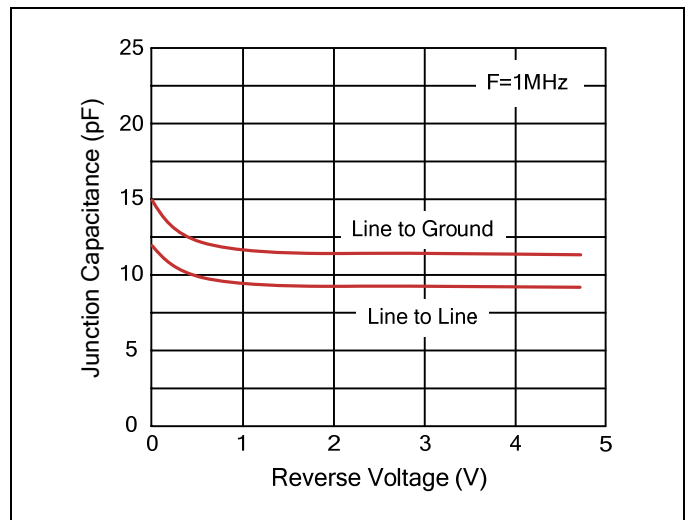
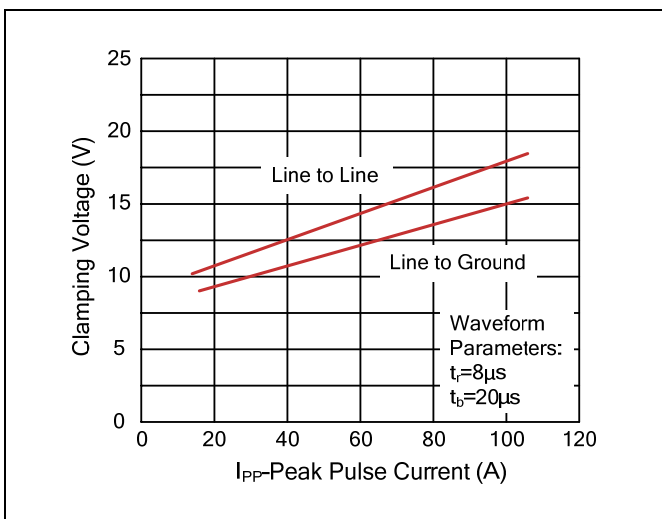
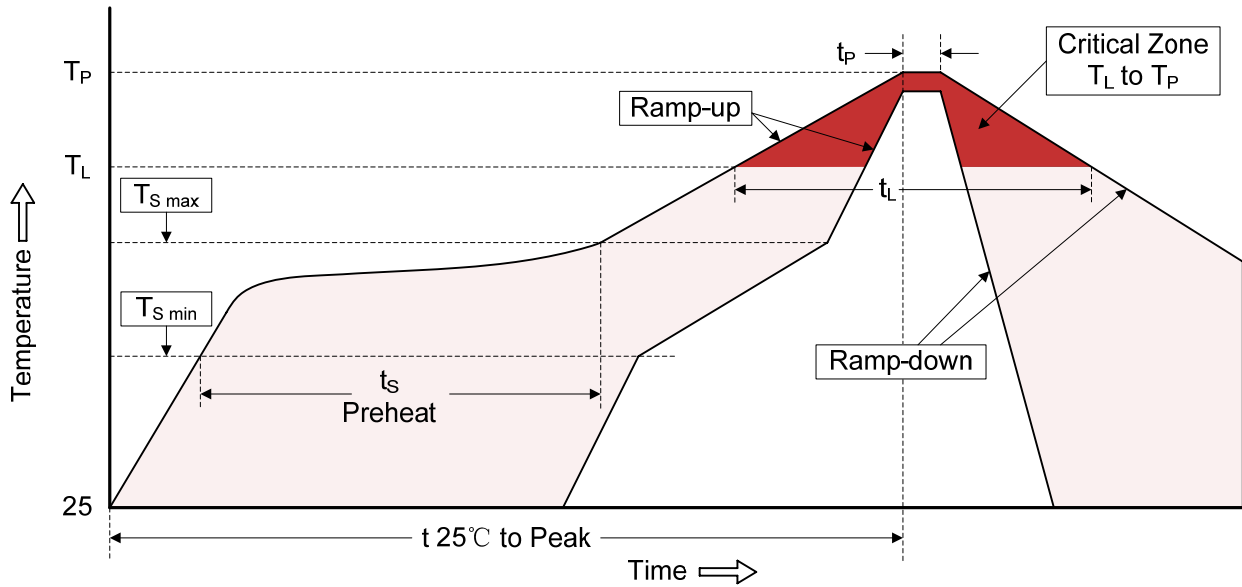

Figure 5. Clamping Voltage vs. Peak Pulse Current



Recommended Soldering Conditions

Reflow Soldering



Recommended Conditions

Profile Feature	Pb-Free Assembly
Average ramp-up rate (T_L to T_P)	3°C/second max.
Preheat -Temperature Min ($T_{S\ min}$) -Temperature Max ($T_{S\ max}$) -Time (min to max) (t_s)	150°C 200°C 60-180 seconds
$T_{S\ max}$ to T_L -Ramp-up Rate	3°C/second max.
Time maintained above: -Temperature (T_L) -Time (t_L)	217°C 60-150 seconds
Peak Temperature (T_P)	260°C
Time within 5°C of actual Peak Temperature (t_p)	20-40 seconds
Ramp-down Rate	6°C/second max.
Time 25°C to Peak Temperature	8 minutes max.

Dimensions (SOIC-08)

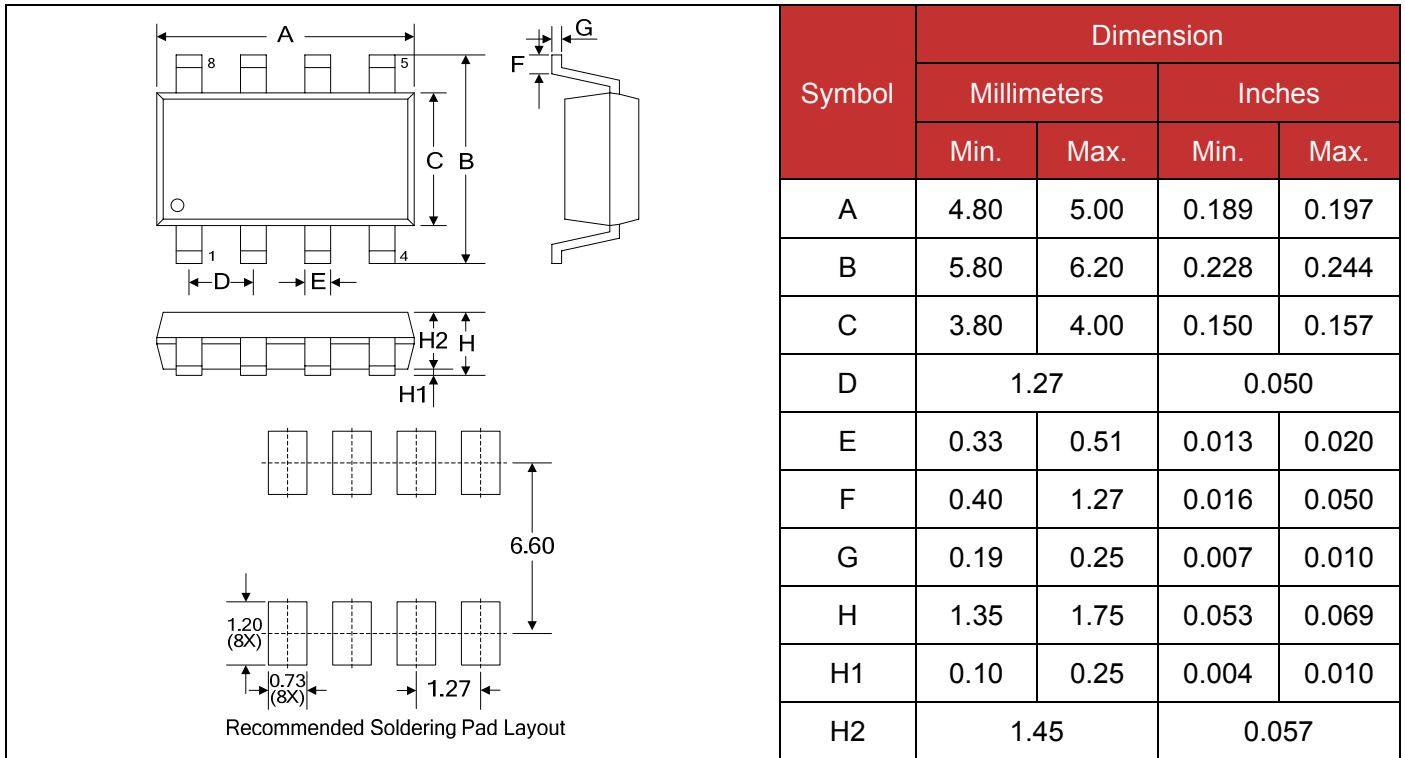

Packaging

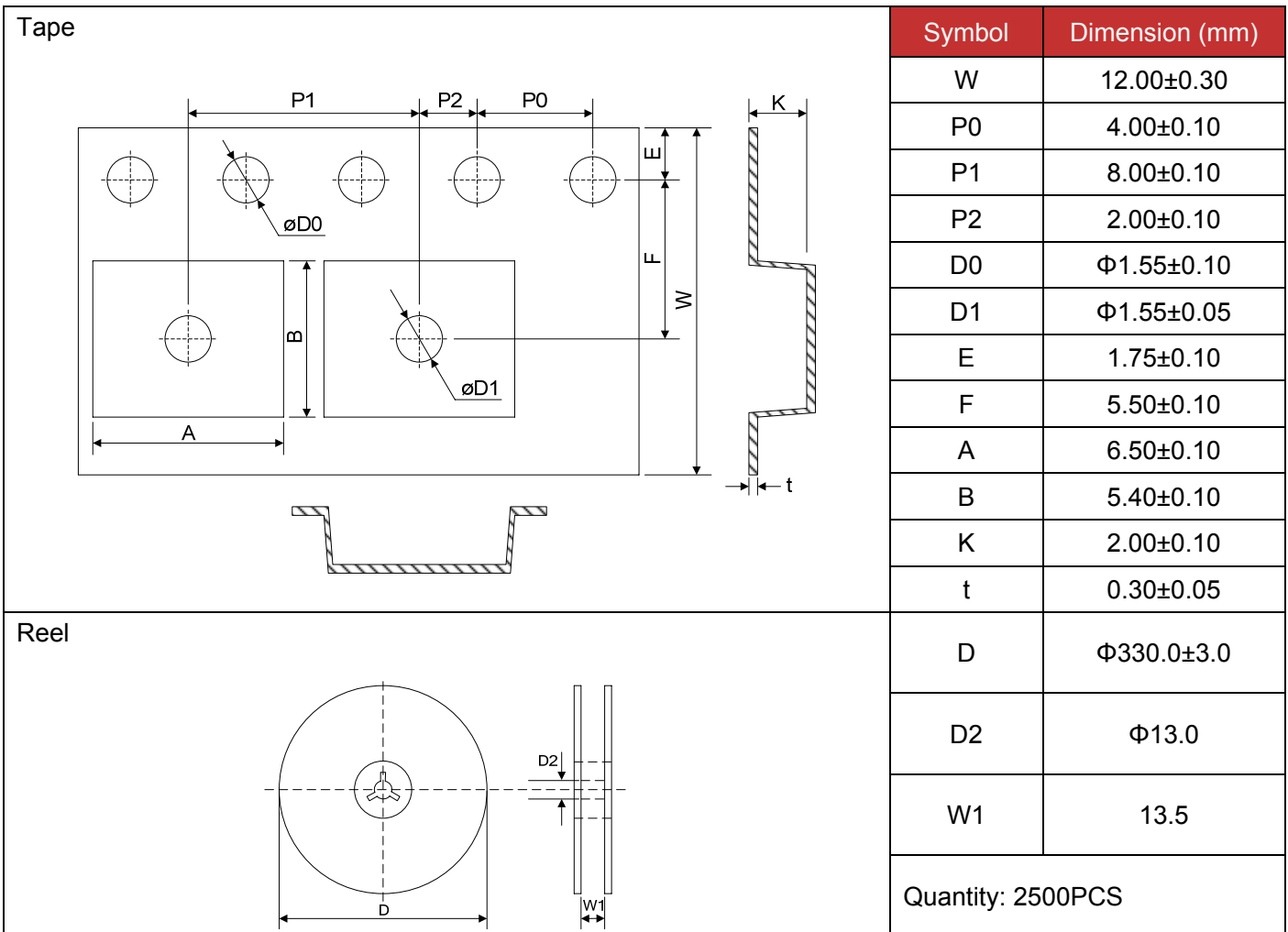

单击下面可查看定价，库存，交付和生命周期等信息

[>>Brightking\(君耀电子\)](#)