

# Current Transducer

## HAS 50 .. 600-S/SP50

$I_{PN} = 50 \dots 600 \text{ A}$

For the electronic measurement of currents: DC, AC, pulsed..., with galvanic isolation between the primary circuit (high power) and the secondary circuit (electronic circuit).

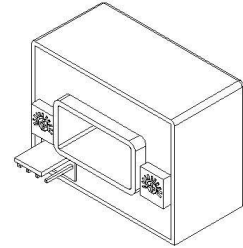

### Electrical data

Type	Primary nominal current rms	Primary current, measuring range <sup>1)</sup>	RoHS since date code
	$I_{PN}$ (A)	$I_{PM}$ (A)	
HAS 50-S/SP50	50	± 150	76348
HAS 100-S/SP50	100	± 300	76348
HAS 200-S/SP50	200	± 600	76348
HAS 300-S/SP50	300	± 900	76349
HAS 400-S/SP50	400	± 900	76349
HAS 500-S/SP50	500	± 900	76349
HAS 600-S/SP50	600	± 900	76349

$V_C$	Supply voltage (± 5 %) <sup>1)</sup>	± 15	V
$I_C$	Current consumption	± 15	mA
$R_{IS}$	Isolation resistance @ 500 VDC	> 1000	MΩ
$V_{OUT}$	Output voltage (Analog) @ ± $I_{PN}$ , $R_L = 10 \text{ k}\Omega$ , $T_A = 25^\circ\text{C}$	± 4V ± 40	mV
$R_{OUT}$	Output internal resistance	approx. 100	Ω
$R_L$	Load resistance <sup>2)</sup>	> 1	kΩ

### Accuracy - Dynamic performance data

$X$	Accuracy @ $I_{PN}$ , $T_A = 25^\circ\text{C}$ (excluding offset)	< ± 1	%
$\epsilon_L$	Linearity error <sup>3)</sup> (0 .. ± $I_{PN}$ )	< ± 1	% of $I_{PN}$
$V_{OE}$	Electrical offset voltage, $T_A = 25^\circ\text{C}$	< ± 20	mV
$V_{OH}$	Hysteresis offset voltage @ $I_P = 0$ , after an excursion of $1 \times I_{PN}$	< ± 20	mV
$TCV_{OE}$	Temperature coefficient of $V_{OE}$	HAS 50-S/SP50 < ± 2 HAS 100 .. 600-S/SP50 < ± 1	mV/K mV/K
$TCV_{OUT}$	Temperature coefficient of $V_{OUT}$ (% of reading)	< ± 0.1	%/K
$t_r$	Response time to 90 % of $I_{PN}$ step	< 3	μs
$di/dt$	di/dt accurately followed	> 50	A/μs
$BW$	Frequency bandwidth (- 3 dB) <sup>4)</sup>	DC .. 50	kHz

### General data

$T_A$	Ambient operating temperature	- 10 .. + 80	°C
$T_S$	Ambient storage temperature	- 25 .. + 80	°C
$m$	Mass	approx. 60	g
	Standards <sup>5)</sup>	EN 50178: 1997	

### Features

- Hall effect measuring principle
- Galvanic isolation between primary and secondary circuit
- Isolation voltage 3000 V
- Low power consumption
- Extended measuring range (3 x  $I_{PN}$ )
- Insulated plastic case made of polycarbonate PBT recognized according to UL 94-V0.

### Advantages

- Easy mounting
- Small size and space saving
- Only one design for wide current ratings range
- High immunity to external interference.

### Applications

- AC variable speed drives
- Static converters for DC motor drives
- Battery supplied applications
- Uninterruptible Power Supplies (UPS)
- Switched Mode Power Supplies (SMPS)
- Power supplies for welding applications.

### Application domain

- Industrial.

## Current Transducer HAS 50 .. 600-S/SP50

### Isolation characteristics

$V_d$	Rms voltage for AC isolation test, 50 Hz, 1 min	3.6	kV
$\hat{V}_w$	Impulse withstand voltage 1.2/50 $\mu$ s	> 6.6	kV
		Min	
<b>dCp</b>	Creepage distance	7.08	mm
<b>dCI</b>	Clearance distance	6.23	mm
<b>CTI</b>	Comparative Tracking Index (group IIIa)	275	

### Applications examples

According to **EN 50178** and **IEC 61010-1** standards and following conditions:

- Over voltage category OV 3
- Pollution degree PD2
- Non-uniform field

	EN 50178	IEC 61010-1
<b>dCp, dCI, <math>\hat{V}_w</math></b>	Rated isolation voltage	Nominal voltage
Single isolation	600 V	600 V
Reinforced isolation	300 V	300 V

### Safety



This transducer must be used in electric/electronic equipment with respect to applicable standards and safety requirements in accordance with the manufacturer's operating instructions.



Caution, risk of electrical shock

When operating the transducer, certain parts of the module can carry hazardous voltage (eg. primary busbar, power supply).

Ignoring this warning can lead to injury and/or cause serious damage.

This transducer is a build-in device, whose conducting parts must be inaccessible after installation.

A protective housing or additional shield could be used.

Main supply must be able to be disconnected.

## Dimensions HAS 50 .. 600-S/SP50 (in mm. 1 mm = 0.0394 inch)

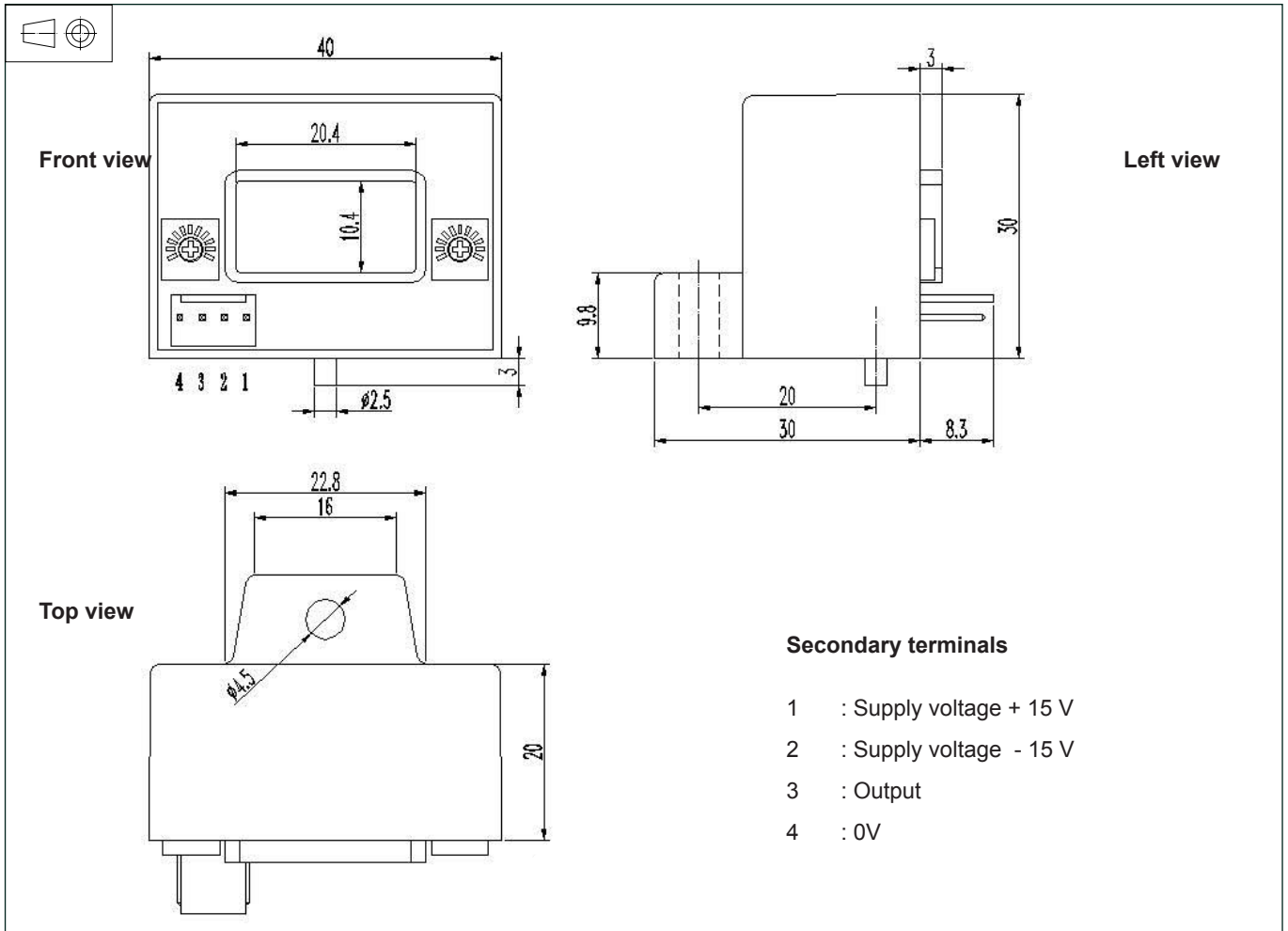

### Mechanical characteristic

- General tolerance  $\pm 0.5$  mm

- Notes:**
- <sup>1)</sup> Operating at  $\pm 12 \text{ V} \leq V_c < \pm 15 \text{ V}$  will reduce the measuring range
  - <sup>2)</sup> If the customer uses 1 k $\Omega$  of the load resistor, the primary current has to be limited as the nominal;  
To measure the full defined measuring range, the load resistor should be at minimum 10 k $\Omega$
  - <sup>3)</sup> Linearity data exclude the electrical offset
  - <sup>4)</sup> Please refer to derating curves in the technical file to avoid excessive core heating at high frequency
  - <sup>5)</sup> Please consult characterisation report for more technical details and application advice.

单击下面可查看定价，库存，交付和生命周期等信息

[>>LEM\(莱姆\)](#)