

**High capacity DC cutoff  
100A at 100V DC**

# EJ RELAYS (AEJ)

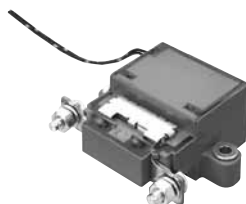

**RoHS compliant**

Protective construction: Dust cover type

### FEATURES

**1. Compact and high capacity using double contacts in series and permanent magnet installed**

1) Nominal switching capacity (resistive load): 100A 100V DC, Min. 10<sup>4</sup>

2) Max. cut-off current: 800A 100V DC

**2. Compact and lightweight for space savings**

70mm (L) × 80mm (W) × 34mm (H)

2.756inch (L) × 3.150inch (W) ×

1.339inch (H)

**3. Environmentally friendly**

In consideration of the environment, cadmium-free contacts, lead-free solder are used.

### TYPICAL APPLICATIONS

Quick recharging power supplies for AGVs (automatic guided vehicle), UPS (uninterruptible power supplies), Fuel cell, Combined heat/power generation system, etc.

### ORDERING INFORMATION

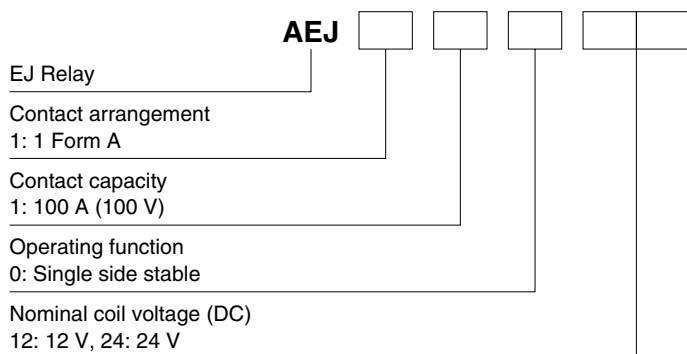

### TYPES

Contact arrangement	Nominal coil voltage	Protective construction	Terminal shape	Part No.
1 Form A	12V DC	Dust cover	Screw terminal	AEJ11012
	24V DC			AEJ11024

Standard packing: Carton: 1 pc.; Case: 20 pcs.

### RATING

#### 1. Coil data

Nominal coil voltage	Pick-up voltage (at 20°C 68°F)	Drop-out voltage (at 20°C 68°F)	Nominal coil current [±10%] (at 20°C 68°F)	Coil resistance [±10%] (at 20°C 68°F)	Nominal operating power (at 20°C 68°F)	Max. applied voltage (at 20°C 68°F)
12V DC	75%V or less of nominal voltage (Initial)	8.3%V or more of nominal voltage (Initial)	417mA	28.8Ω	5.0W	133%V of nominal voltage
24V DC			208mA	115.2Ω	5.0W	

## 2. Specifications

Characteristics	Item	Specifications	
Rating	Arrangement	1 Form A	
	Contact voltage drop (Initial)	Max. 0.15V (at 100A)	
	Contact material	Ag alloy type	
	Nominal switching capacity (resistive load)	100A 100V DC	
	Max. carrying current/short time carrying current	1,000A (0.1s)	
	Min. switching capacity (Reference value)*1	1A 12V DC	
	Max. cut-off current	800A 100V DC 3 cycle*3	
	Overload opening rating	300A 150V DC 10 cycle	
Electrical characteristics	Insulation resistance (Initial)	Min. 100MΩ (at 500V DC) Measurement at same location as "Breakdown voltage" section.	
	Breakdown voltage (Initial)	Between open contacts	1,500 Vrms for 1min. (Detection current: 10mA.)
		Between contact and coil	2,500 Vrms for 1min. (Detection current: 10mA.)
	Operate time (at 20°C 68°F)	Max. 30ms (Nominal voltage applied to the coil, excluding contact bounce time)	
Release time (at 20°C 68°F)	Max. 15ms (Nominal voltage applied to the coil)		
Mechanical characteristics	Shock resistance	Functional	Min. 500 m/s <sup>2</sup> (Nominal voltage applied to the coil) Min. 50 m/s <sup>2</sup> (deenergized) (Half-wave pulse of sine wave: 11 ms; detection time: 10μs.)
		Destructive	Min. 1000 m/s <sup>2</sup> (Nominal voltage applied to the coil or deenergized.) (Half-wave pulse of sine wave: 6 ms)
	Vibration resistance	Functional	10 to 200Hz, 44.1m/s <sup>2</sup> (Nominal voltage applied to the coil or deenergized)
		Destructive	10 to 200Hz, 44.1m/s <sup>2</sup> (Nominal voltage applied to the coil or deenergized) (Time of vibration for each direction; X, Y, Z direction: 4 hours)
Expected life	Mechanical	Min. 10 <sup>6</sup>	
	Electrical	Min. 10 <sup>4</sup> (at 100A 100V DC) (Resistive load, operating frequency 1s ON, 9s OFF, room temperature)	
Conditions	Conditions for operation, transport and storage*2	Ambient temperature: -40°C to +85°C -40°F to +185°F	
Unit weight		Approx. 300g 10.58oz	

Notes: \*1. This value can change due to the switching frequency, environmental conditions and desired reliability level, therefore it is recommended to check this with the actual load.  
 \*2. The upper limit of the ambient temperature is the maximum temperature that can satisfy the coil temperature rise value. Refer to Usage, transport and storage conditions in NOTES.  
 \*3. Condition: Nominal switching 100cycles, each cut off 800A  
 \*4. When using a surge absorbing element for the relay coil drive circuit, please use with a surge absorbing element with a clamp voltage of 1.5 to 2.0 times the rated operating voltage. When the coil is connected in parallel with a diode, resistor or capacitor, the release time will delay which might lead to degradation in shutoff performance and electrical life. Contact terminals have polarity; therefore, please obey the wiring diagram when connecting contacts. The electrical load performance value applies when a varistor is connected in parallel with the coil.

## REFERENCE DATA

### 1. Maximum value for switching capacity

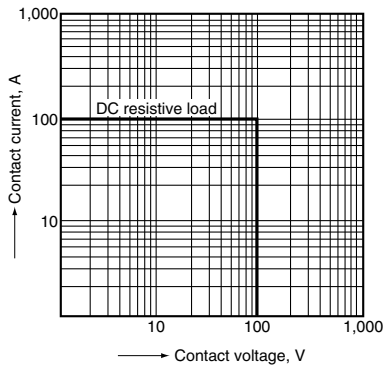

### 2. Carrying current limit

Connection electric wire: 40mm<sup>2</sup>  
 Ambient temperature: 85°C 185°F  
 Standard for judgment: Relay contacts off when carrying finished.

### Carrying current and carrying time

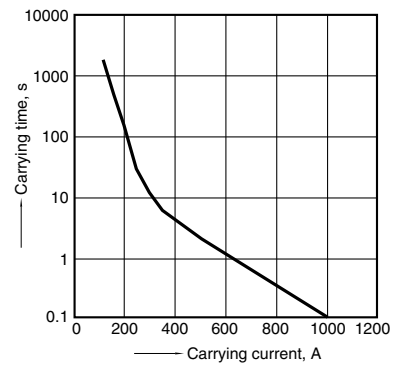

### 3. Distribution of pick-up and drop-out voltages

Tested sample: AEJ11012, 50 pcs.

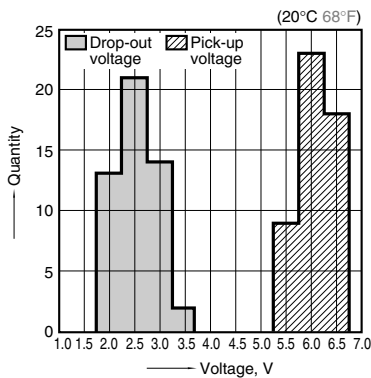

### 4. Distribution of operate time

Tested sample: AEJ11012, 50 pcs.

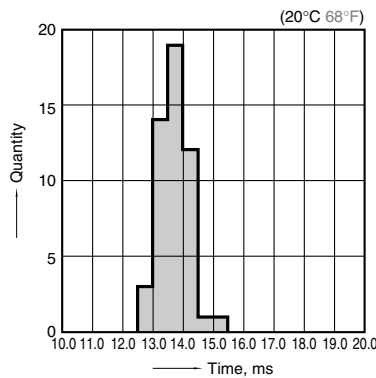

### 5. Distribution of release time

Tested sample: AEJ11012, 50 pcs.

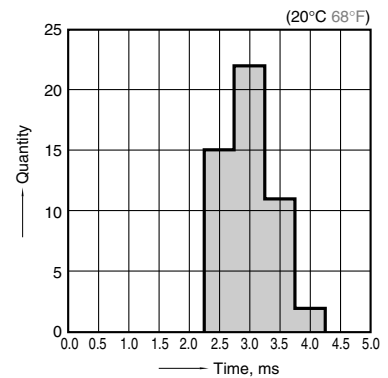

6. Functional shock resistance

Tested sample: AEJ11012, 3 pcs.  
 Half-wave pulse of sine wave: 11 ms  
 Detection time: 10μs.  
 Applied direction: 6 directions  
 Applied cycle: Each of 3 cycles

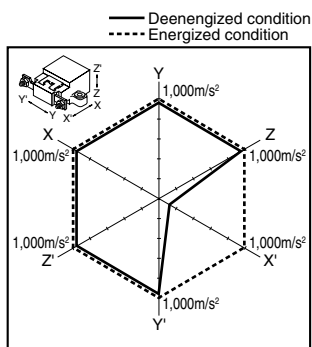

**DIMENSIONS** (mm inch)

The CAD data of the products with a **CAD Data** mark can be downloaded from: <http://industrial.panasonic.com/ac/e/>

**CAD Data**

External dimensions

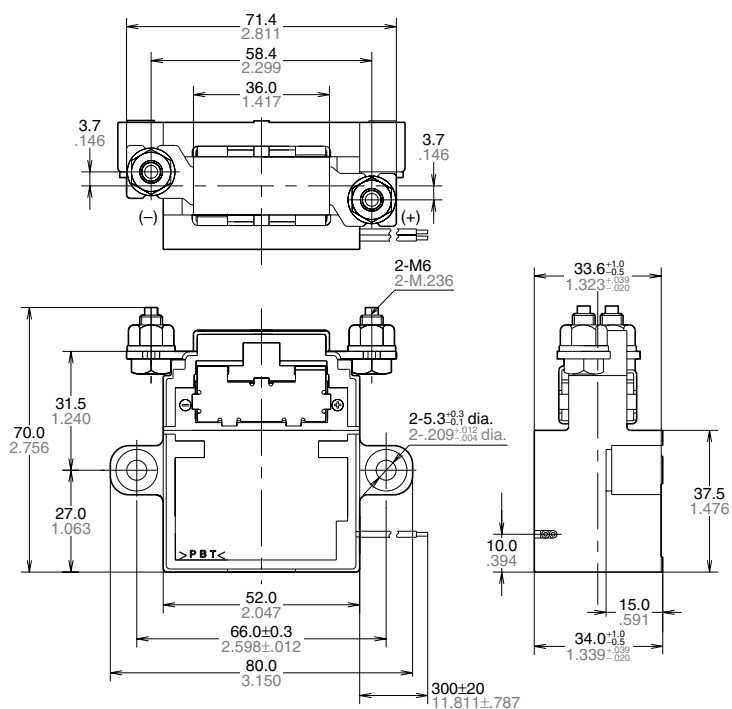

Schematic (Top view)

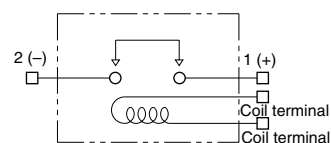

Mounting hole pattern (Top view)

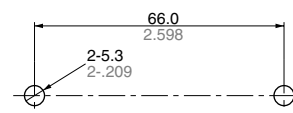

Tolerance: ±0.1 ±.004

Dimension:	General tolerance
Less than 10mm .394inch:	±0.3 ±.012
10 to 50mm .394 to 1.969inch:	±0.6 ±.024
Min. 50mm 1.969 inch:	±1.0 ±.039

Notes: 1. Please be warned that contact terminals have polarity. There is no polarity in the coil input line.  
 2. Cross-sectional area of coil lead wire: 0.5mm<sup>2</sup>

## NOTES

1. For cautions for use, please read "GENERAL APPLICATION GUIDELINES" on page B-1.

2. To ensure proper operation, the voltage applied to the coil should be the rated operating voltage of the coil. Also, be aware that the pick-up and drop-out voltages will fluctuate depending on the ambient temperature and operating conditions.

3. Heat, smoke, and even a fire may occur if the relay is used in conditions outside of the allowable ranges for the coil ratings, contact ratings, operating cycle lifetime, and other specifications. Therefore, do not use the relay if these ratings are exceeded.

4. If the relay has been dropped, the appearance and characteristics should always be checked before use.

5. This relay is for DC loads. Do not use it for AC load switching.

6. Make sure that the relay is wired correctly. Incorrect wiring may cause unexpected events or the generation of heat or flames.

7. We recommend you use a surge absorbing element with a clamp voltage of 1.5 to 2.0 times the rated operating voltage for the relay coil drive circuit as a means for relay coil surge absorption. Please avoid the use of diodes, capacitors and resistors because they lead to degradation in cut-off performance.

8. Avoid mounting the relay in strong magnetic fields (near a transformer or magnet) or close to an object that radiates heat.

### 9. Electrical life

This relay is a high-voltage direct-current switch. In its final breakdown mode, it may lose the ability to provide the proper cut-off. Therefore, do not exceed the indicated switching capacity and life. (Please treat the relay as a product with limited life and replace it when necessary.)

In the event that the relay loses cut-off ability, there is a possibility that burning may spread to surrounding parts, so configure the layout so that the power is turned off within one second.

10. If the power is turned off and then immediately on after applying the rated voltage (current) continuously to the relay's coil and contact, the resistance of the coil will increase due to a rise in the coil temperature. This causes the pick-up voltage to rise, and possibly exceed the rated pick-up voltage. In these circumstances, take measures such as reducing the load current, limiting the duration of current flow, and applying a coil voltage higher than the rated operating voltage (quick start).

11. If you are using an inductive load (L load) such that  $L/R > 1$  ms, add surge protection in parallel with the inductive load. If this is not done, the electrical life will decrease and cut-off failure may occur.

12. Be careful that foreign matter and oils and fats kind doesn't stick to the main terminal part because it is likely to cause a terminal part to give off unusual heat.

13. Avoid excessive load applied to the terminal in case of installing such as a bus bar etc., because it might give bad influence to the opening and closing performance.

Tighten each of the screws within the rated ranges given below.

Main terminal (M6 screw):

6.0N·m to 8.0N·m

Main unit mounting (M5 screw):

2.5N·m to 3.6N·m

### 14. Usage, transport and storage conditions

Ambient temperature, humidity, and atmospheric pressure during usage, transport, and storage of the relay:

1) Temperature:  $-40$  to  $+85^{\circ}\text{C}$   $-40$  to  $+185^{\circ}\text{F}$

2) Humidity: 5 to 85% RH (Avoid freezing and condensation.)

3) Atmospheric pressure: 85 to 106 kPa  
Temperature and humidity range for usage, transport, and storage:

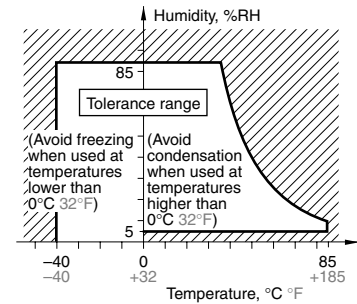

#### 4) Condensation

Condensation forms when there is a sudden change in temperature under high temperature and high humidity conditions. Condensation will cause deterioration of the relay insulation.

#### 5) Freezing

Condensation or other moisture may freeze on the relay when the temperatures is lower than  $0^{\circ}\text{C}$   $32^{\circ}\text{F}$ . This causes problems such as sticking of movable parts or operational time lags.

#### 6) Low temperature, low humidity environments

The plastic becomes brittle if the relay is exposed to a low temperature, low humidity environment for long periods of time.

单击下面可查看定价，库存，交付和生命周期等信息

[>>Panasonic\(松下\)](#)