

XC62G Series

Positive Voltage Regulators (Output On/Off)



- ◆ **CMOS Low Power Consumption**
- ◆ **Small Input-Output Voltage Differential**
: 0.2V @ 80mA,
0.38V @ 160mA
- ◆ **Maximum Output Current**
: 150mA (V_{OUT} = 3.0V)
- ◆ **Highly Accurate** : ±2% (±1%)
- ◆ **Output Voltage Range**
: 2.1V ~ 5.0V
- ◆ **Stand-by Supply Current**
: 0.1μA (V_{OUT} = 3.0V)
- ◆ **SOT-25 / SOT-89-5 Package**

General Description

The XC62G series are highly precise, low power consumption positive voltage regulators, manufactured using CMOS and laser trimming technologies. The series achieves high output currents, with low input-output voltage differentials, and consists of a high precision voltage reference, an error correction circuit, and an output driver with current limitation. With good transient responses, output remains stable even during load changes. Also, having high ripple rejection ratios, the series can be used with low power supply noise. The CE input enables the output to be turned off, resulting in reduced power consumption. SOT-25 (150mW) and SOT-89-5 (500mW) packages are available. With regards to the CE function, as well as the positive logic XC62GR series, a negative logic XC62GP series (custom) is also available.

Applications

- Battery-powered Equipment
- Voltage supplies for cellular phones
- Cameras, Video Recorders
- Palmtops

Features

- Maximum Output Current** : 150mA (within max. power dissipation, V_{OUT}=3.0V)
- Output Voltage Range** : 2.1V~5.0V in 0.1V increments
- Highly Accurate** : Set-up voltage ±2%
(±1% for semi-custom products)
- Low Power Consumption**
: TYP. 13μA (V_{OUT}= 3.0V),
TYP 23μA (V_{OUT}=3.0V semi-custom, high-speed versions),
TYP 0.1μA (Stand-by mode)
- Output Voltage Temperature Characteristics**
: TYP ±100ppm/°C
- Input Stability** : TYP 0.2%/V
- Ultra Small Packages** : SOT-25 (150mW) mini-mold
SOT-89-5 (500mW) mini-power mold

Typical Application Circuit

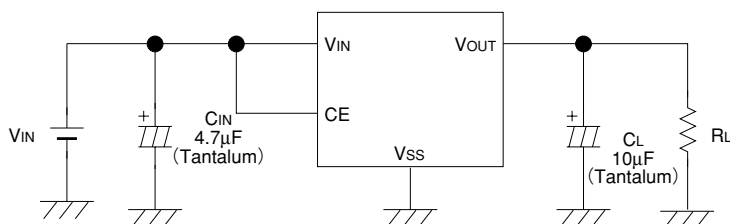

Typical Performance Characteristic

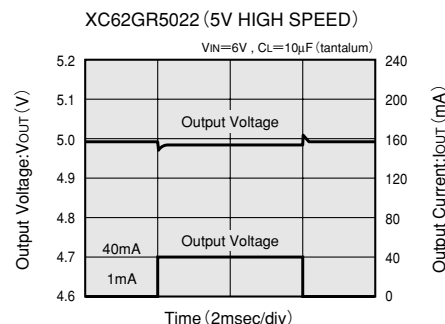

Pin Configuration

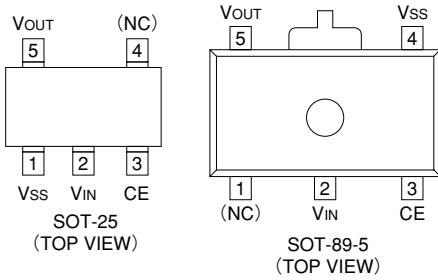

Pin Assignment

PIN NUMBER		PIN NAME	FUNCTION
SOT-25	SOT-89-5		
1	4	V _{SS}	Ground
2	2	V _{IN}	Supply Voltage input
3	3	CE	Chip Enable
4	1	(NC)	No Connection
5	5	V _{OUT}	Regulated Output Voltage

3

Function List

SERIES	CE	VOLTAGE OUTPUT
XC62GR	H	ON
	L	OFF
XC62GP	H	OFF
	L	ON

H=High, L=Low

Product Classification

Ordering Information

X C 6 2 G X X X X X X X
 ↑ ↑ ↑ ↑ ↑ ↑
 a b c d e f

DESIGNATOR	DESCRIPTION	DESIGNATOR	DESCRIPTION
a	True Logic Level at CE Pin: R=Positive P=Negative(Custom)	e	Package Type M=SOT-25 P=SOT-89-5
b	Output Voltage 30=3.0V 50=5.0V		
c	Response: 1=Standard 2=High Speed (Semi-Custom)	f	Device Orientation R=Embossed Tape (Standard Feed) L=Embossed Tape (Reverse Feed)
d	Output Voltage Accuracy: 1=±1.0%(Semi-custom) 2=±2.0%		

■ Packaging Information

● SOT-25

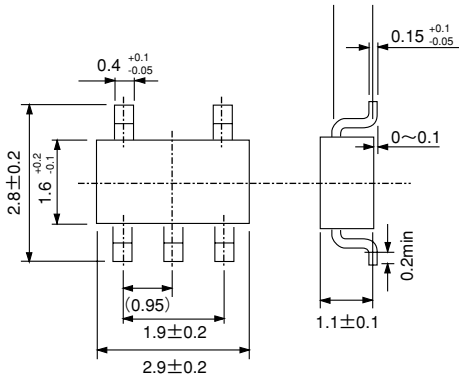

● SOT-89-5

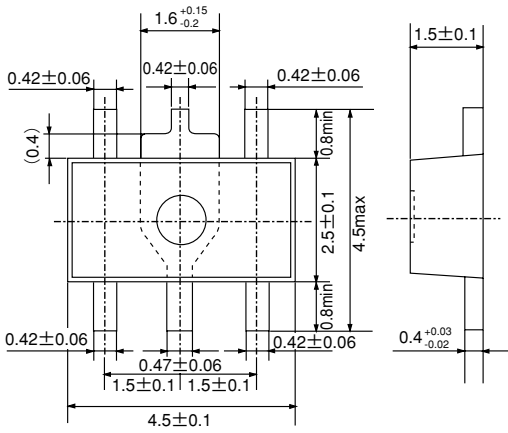

Marking

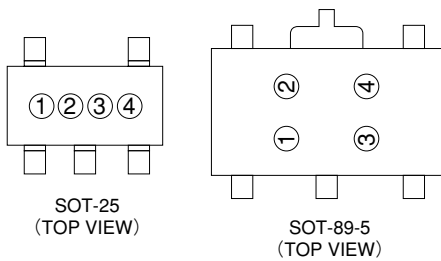

① Represents the integer of the Output Voltage

R TYPE POSITIVE VOLTAGE LOGIC SYMBOL	VOLTAGE(V)	P TYPE NEGATIVE VOLTAGE LOGIC SYMBOL	VOLTAGE(V)
A	0.②	\bar{A}	0.②
B	1.②	\bar{B}	1.②
C	2.②	\bar{C}	2.②
D	3.②	\bar{D}	3.②
E	4.②	\bar{E}	4.②
F	5.②	\bar{F}	5.②
H	6.②	\bar{H}	6.②

3

② Represents the decimal number of the Output Voltage

SYMBOL	VOLTAGE(V)	SYMBOL	VOLTAGE(V)
A	①.0	F	①.5
B	①.1	H	①.6
C	①.2	K	①.7
D	①.3	L	①.8
E	①.4	M	①.9

③ Represents the transition response

SYMBOL	TRANSITION RESPONSE
-	REGULAR
+	HIGH SPEED

④ Represents the assembly lot no.

0-9,A-Z repeated (G, I, J, O, Q, W excepted)

Block Diagram

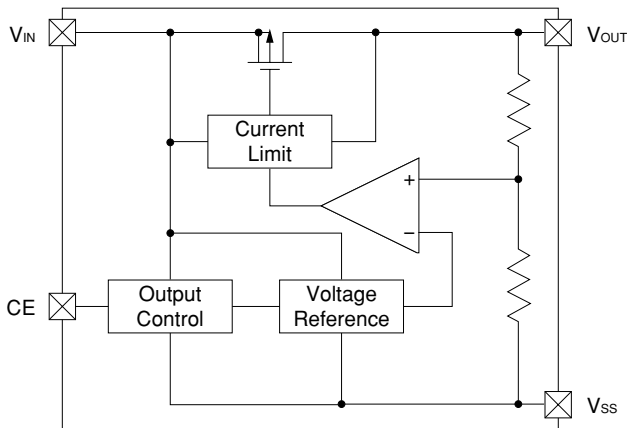

Absolute Maximum Ratings

$T_a=25^\circ\text{C}$

PARAMETER	SYMBOL	RATINGS	UNITS
Input Voltage	V_{IN}	12	V
Output Current	I_{OUT}	500	mA
Output Voltage	V_{OUT}	$V_{SS}-0.3\sim V_{IN}+0.3$	V
CE Input Voltage	V_{CE}	$V_{SS}-0.3\sim V_{IN}+0.3$	V
Continuous Total Power Dissipation	SOT-25	P_d	150
	SOT-89-5	P_d	500
Operating Ambient Temperature	T_{opr}	-30~+80	$^\circ\text{C}$
Storage Temperature	T_{stg}	-40~+125	$^\circ\text{C}$

Note: I_{OUT} must be less than $P_d/(V_{IN}-V_{OUT})$

Electrical Characteristics

XC62GR30 $V_{OUT}(T)=3.0V$ (Note1)

$T_a=25^{\circ}C$

PARAMETER	SYMBOL	CONDITIONS	MIN	TYP	MAX	UNITS	CIRCUT
Output Voltage	$V_{OUT}(E)$ (Note2)	$I_{OUT}=40mA$ $V_{IN}=4.0V$	2.940	3.000	3.060	V	1
Maximum Output Current	$I_{OUT\ max.}$	$V_{IN}=4.0\ V_{OUT}(E)\geq 2.7V$	150			mA	1
Load Stability	ΔV_{OUT}	$V_{IN}=4.0V$ $1mA\leq I_{OUT}\leq 80mA$		45	90	mV	1
Input-Output Voltage Differential (Note3)	V_{DIF1}	$I_{OUT}=80mA$		200	395	mV	1
	V_{DIF2}	$I_{OUT}=160mA$		380	770	mV	1
Supply Current1	I_{SS1}	$V_{IN}=V_{CE}=4.0V$ (Note6)	Standard	11	19	μA	2
			High Speed	23	31	μA	2
Supply Current2	I_{SS2}	$V_{IN}=4.0V, V_{CE}=V_{SS}$			0.1	μA	2
Input Stability	$\frac{\Delta V_{OUT}}{\Delta V_{IN} \cdot V_{OUT}}$	$I_{OUT}=40mA$ $4.0V\leq V_{IN}\leq 10.0V$		0.2	0.3	%/V	1
Input Voltage	V_{IN}				10.0	V	-
Output Voltage Temperature Characteristics	$\frac{\Delta V_{OUT}}{\Delta T_{opr} \cdot V_{OUT}}$	$I_{OUT}=10mA$ $-30^{\circ}C\leq T_{opr}\leq 80^{\circ}C$		± 100		ppm/ $^{\circ}C$	
CE Input Voltage "High"	V_{CEH}		1.5			V	1
CE Input Voltage "Low"	V_{CEL}				0.25	V	1
CE Input Current "High"	I_{CEH}	$V_{CE}=V_{IN}$			5.0	μA	2
CE Input Current "Low"	I_{CEL}	$V_{CE}=V_{SS}$	-0.2	-0.05	0	μA	2

- Note:
- $V_{OUT}(T)$ =Specified Output Voltage .
 - $V_{OUT}(E)$ =Effective Output Voltage (i.e. the output voltage when " $V_{OUT}(T)+1.0V$ " is provided at the V_{IN} pin while maintaining a certain I_{OUT} value).
 - $V_{dif} = \{V_{IN1} \text{ (Note5)} - V_{OUT1} \text{ (Note4)}\}$
 - V_{OUT1} = A voltage equal to 98% of the Output Voltage whenever an amply stabilised I_{OUT} ($V_{OUT}(T)+1.0V$) is input.
 - V_{IN1} = The Input Voltage when V_{OUT1} appears as Input Voltage is gradually decreased.
 - High Speed is Semi-custom.

3

XC62GR50 $V_{OUT}(T)=5.0V$ (Note1)

$T_a=25^\circ C$

PARAMETER	SYMBOL	CONDITIONS	MIN	TYP	MAX	UNITS	CIRCUIT
Output Voltage	$V_{OUT}(E)$ (Note2)	$I_{OUT}=40mA$ $V_{IN}=6.0V$	4.900	5.000	5.100	V	1
Maximum Output Current	$I_{OUT\ max.}$	$V_{IN}=6.0V$ $V_{OUT}(E)\geq 4.5V$	180			mA	1
Load Stability	ΔV_{OUT}	$V_{IN}=6.0V$ $1mA\leq I_{OUT}\leq 100mA$		40	80	mV	1
Input-Output Voltage Differential (Note3)	V_{DIF1}	$I_{OUT}=100mA$		165	330	mV	1
	V_{DIF2}	$I_{OUT}=200mA$		330	660	mV	1
Supply Current1	I_{SS1}	$V_{IN}=V_{CE}=6.0V$ (Note6)	Standard	13	21	μA	2
			High Speed	27	35	μA	2
Supply Current2	I_{SS2}	$V_{IN}=6.0V, V_{CE}=V_{SS}$			0.1	μA	2
Input Stability	$\frac{\Delta V_{OUT}}{\Delta V_{IN} \cdot V_{OUT}}$	$I_{OUT}=40mA$ $6.0V\leq V_{IN}\leq 10.0V$		0.2	0.3	%/V	1
Input Voltage	V_{IN}				10.0	V	-
Output Voltage Temperature Characteristics	$\frac{\Delta V_{OUT}}{\Delta T_{opr} \cdot V_{OUT}}$	$I_{OUT}=40mA$ $-30^\circ C\leq T_{opr}\leq 80^\circ C$		± 100		ppm/ $^\circ C$	
CE Input Voltage "High"	V_{CEH}		1.5			V	1
CE Input Voltage "Low"	V_{CEL}				0.25	V	1
CE Input Current "High"	I_{CEH}	$V_{CE}=V_{IN}$			5.0	μA	2
CE Input Current "Low"	I_{CEL}	$V_{CE}=V_{SS}$	-0.2	-0.05	0	μA	2

- Note:
- $V_{OUT}(T)$ =Specified Output Voltage .
 - $V_{OUT}(E)$ =Effective Output Voltage (i.e. the output voltage when " $V_{OUT}(T)+1.0V$ " is provided at the V_{IN} pin while maintaining a certain I_{OUT} value).
 - $V_{dif} = \{V_{IN1} (Note5) - V_{OUT1} (Note4)\}$
 - V_{OUT1} = A voltage equal to 98% of the Output Voltage whenever an amply stabilised I_{OUT} ($V_{OUT}(T)+1.0V$) is input.
 - V_{IN1} = The Input Voltage when V_{OUT1} appears as Input Voltage is gradually decreased.
 - High Speed is Semi-custom.

Typical Application Circuit

● Standard Circuit

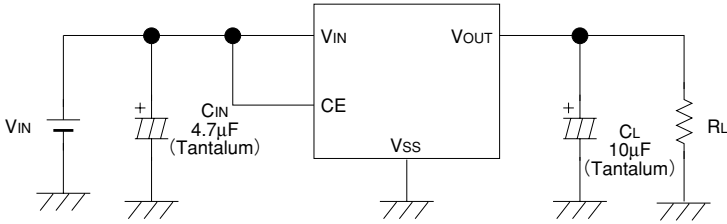

Test Circuits

Circuit 1

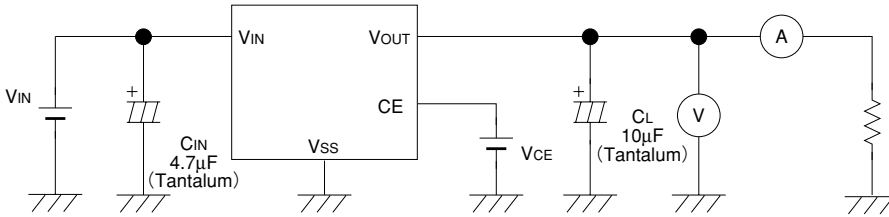

Circuit 2

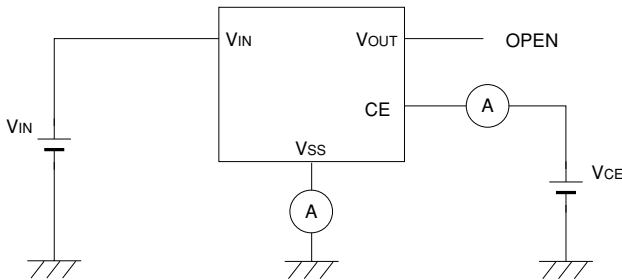

Typical Performance Characteristics

(1) OUTPUT VOLTAGE vs. OUTPUT CURRENT

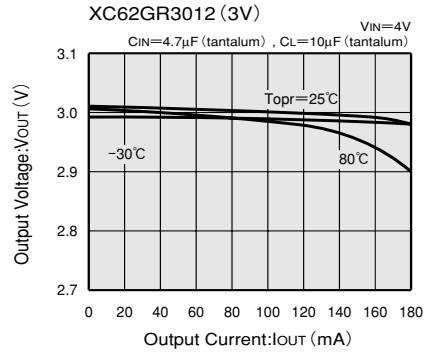
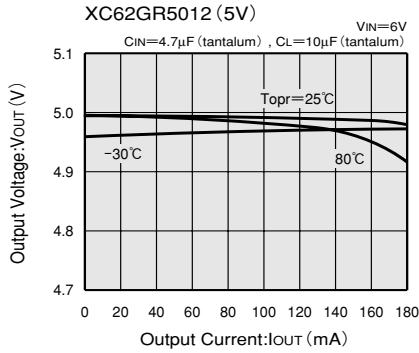

(2) OUTPUT VOLTAGE vs. INPUT VOLTAGE

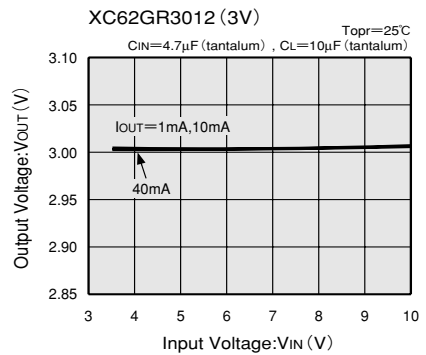
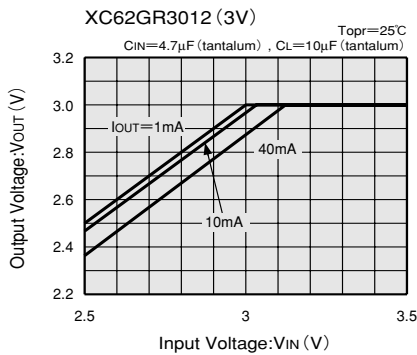
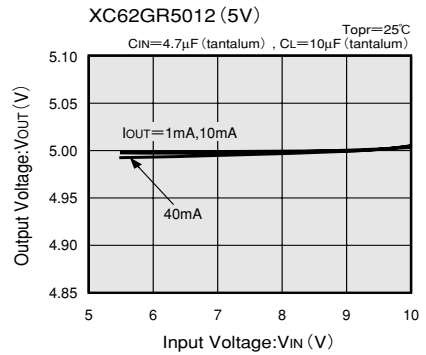
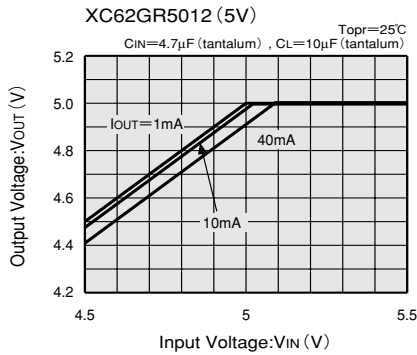

(3) INPUT/OUTPUT VOLTAGE DIFFERENTIAL vs. OUTPUT CURRENT

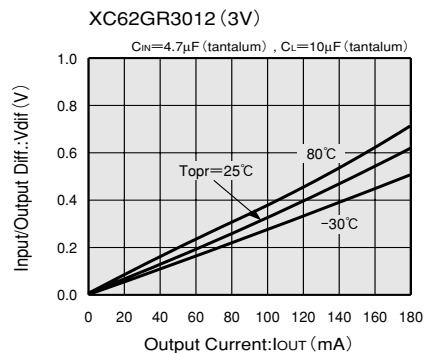
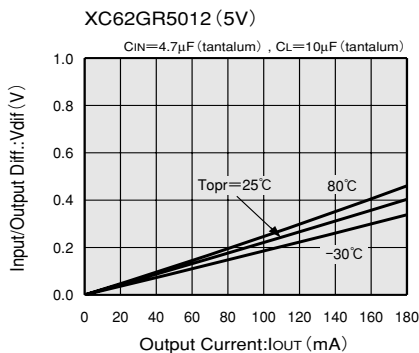

(4) CE PIN THRESHOLD VOLTAGE vs. INPUT VOLTAGE

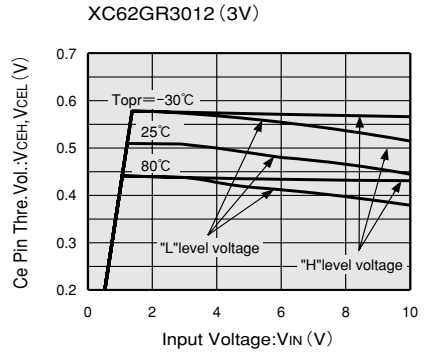
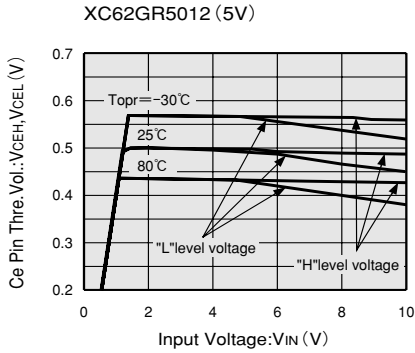

3

(5) SUPPLY CURRENT vs. INPUT VOLTAGE

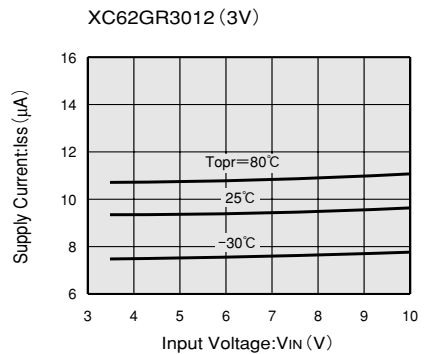
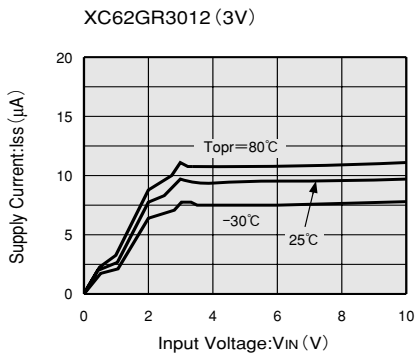
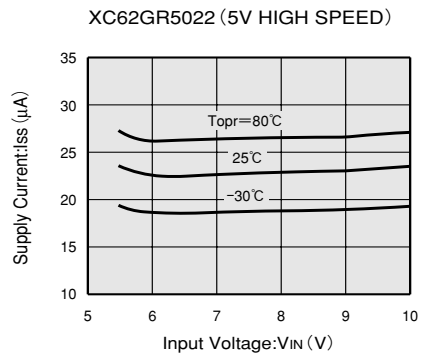
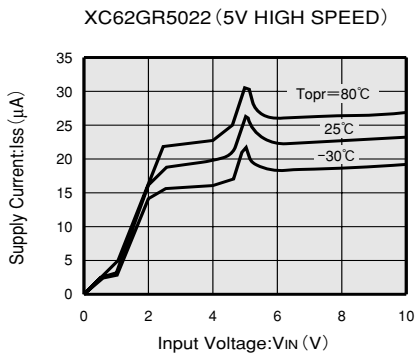
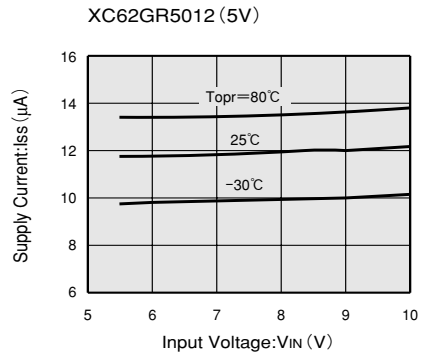
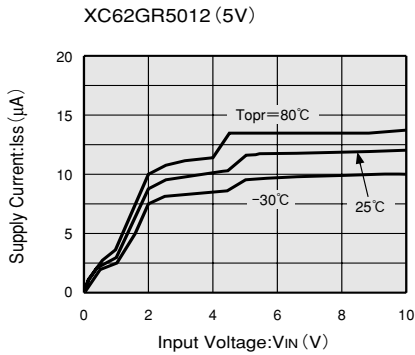

(5) SUPPLY CURRENT vs. INPUT VOLTAGE

XC62GR3022 (3V HIGH SPEED)

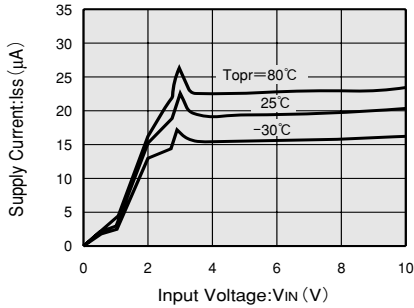

XC62GR3022 (3V HIGH SPEED)

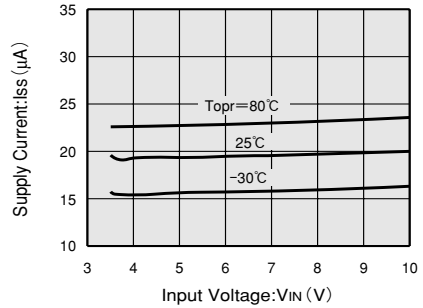

3

(6) OUTPUT VOLTAGE vs. AMBIENT TEMPERATURE

XC62GR5012 (5V)

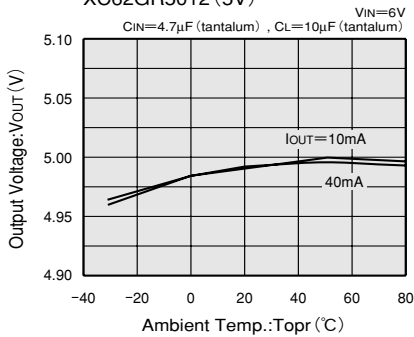

XC62GR3012 (3V)

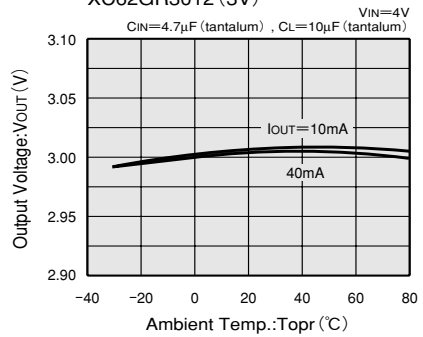

(7) SUPPLY CURRENT vs. AMBIENT TEMPERATURE

XC62GR5012 (5V)

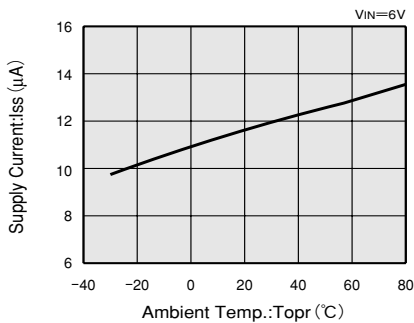

XC62GR5022 (5V HIGH SPEED)

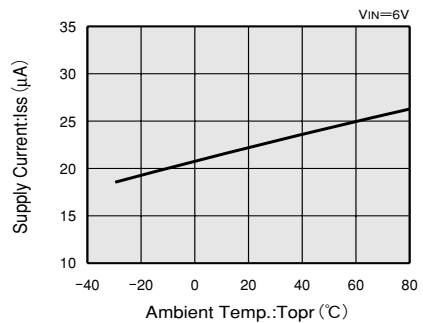

XC62GR3012 (3V)

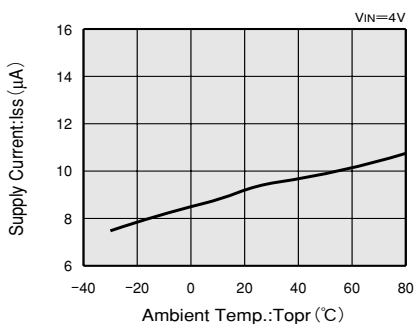

XC62GR3022 (3V HIGH SPEED)

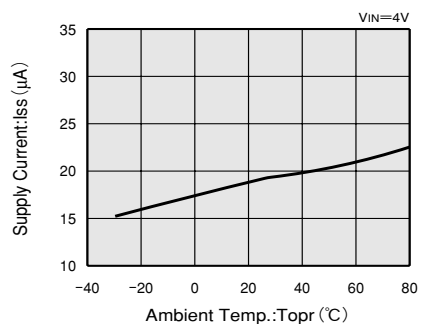

(8) INPUT TRANSIENT RESPONSE 1

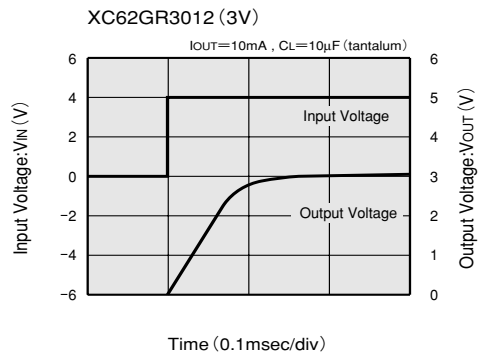
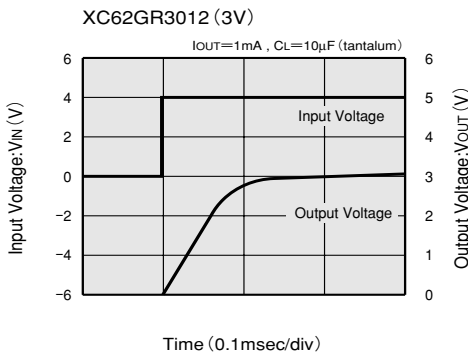
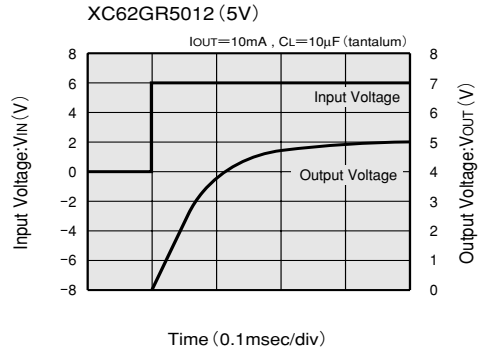
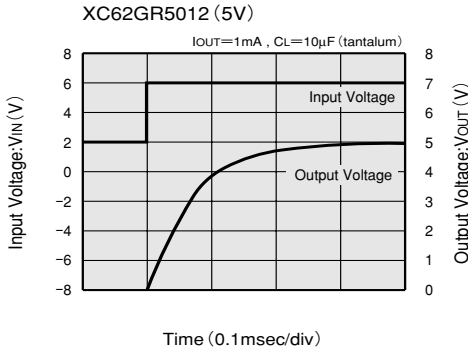

3

(9) INPUT TRANSIENT RESPONSE 2

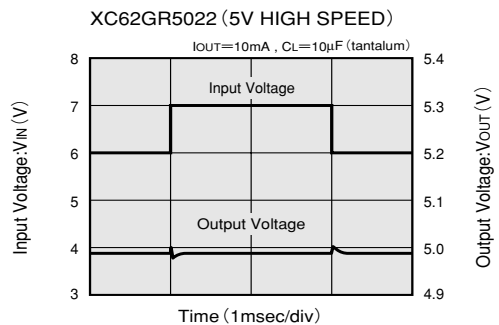
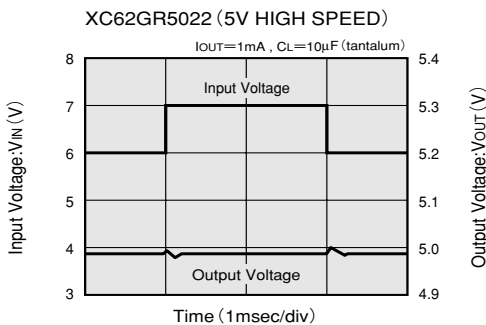
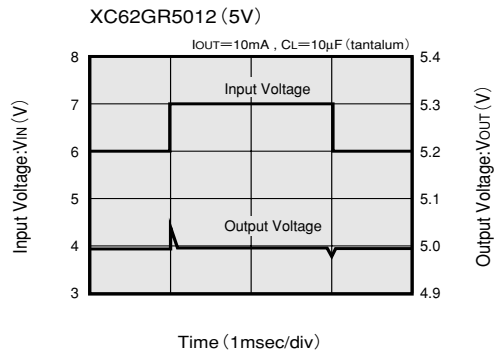
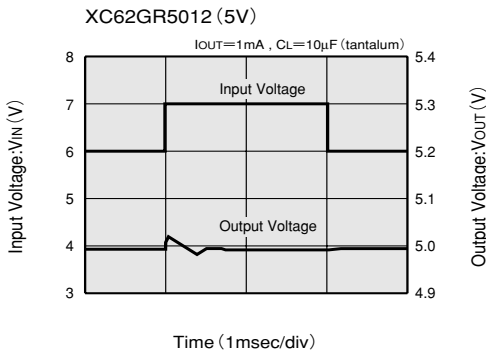

(9) INPUT TRANSIENT RESPONSE 2

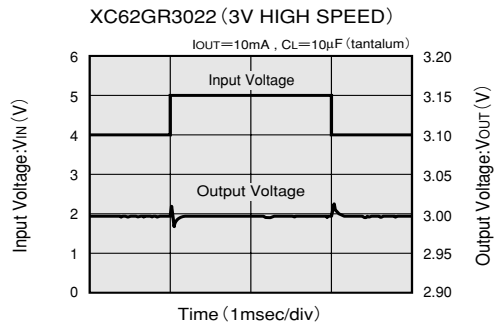
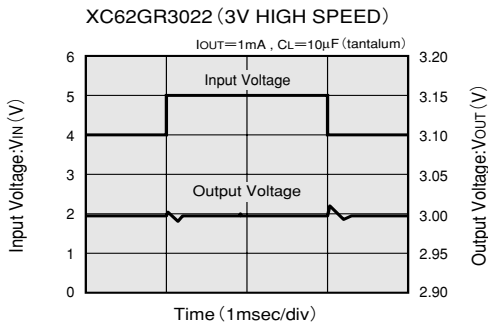
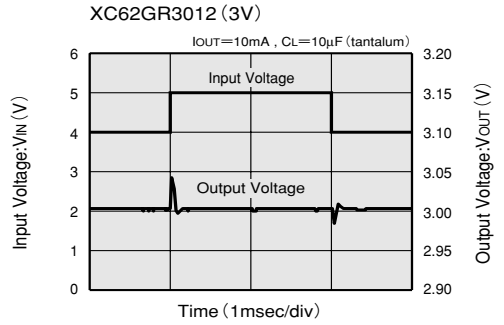
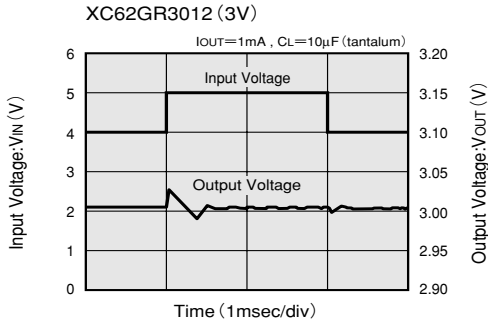

(10) LOAD TRANSIENT RESPONSE

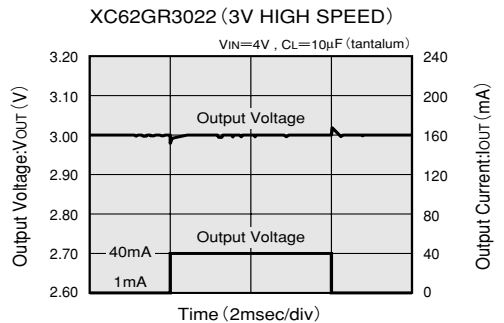
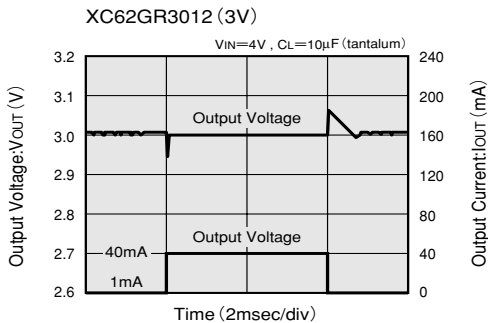
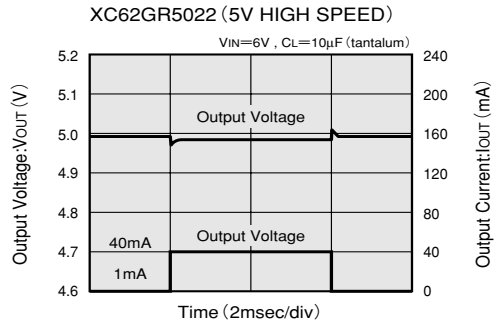
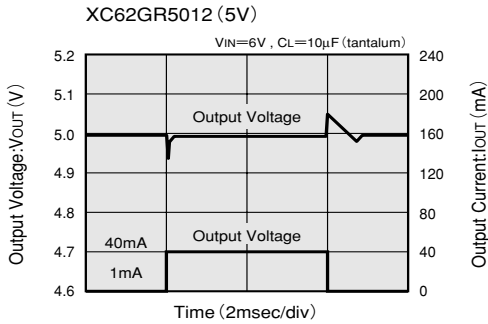

(11) CE PIN TRANSIENT RESPONSE

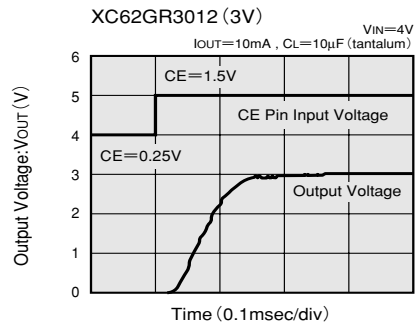
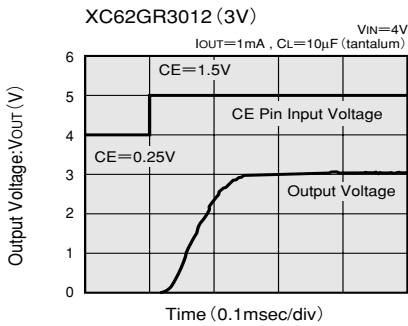
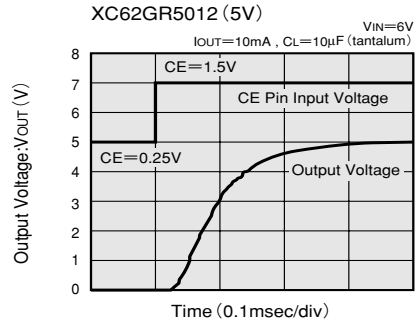
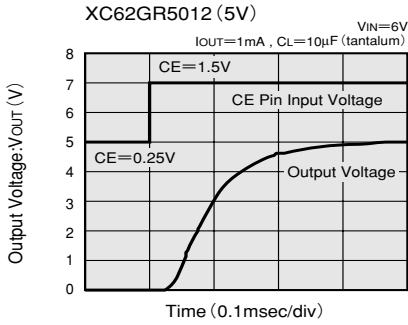

3

(12) RIPPLE REJECTION RATE

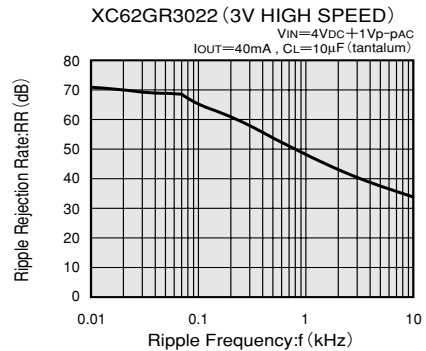
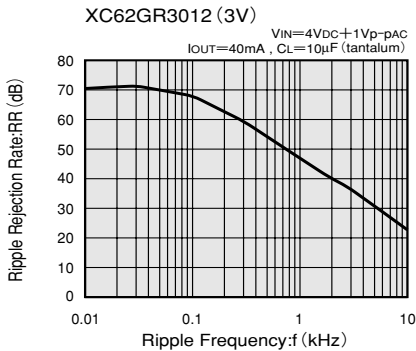
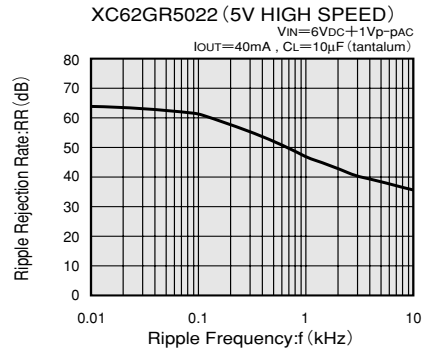
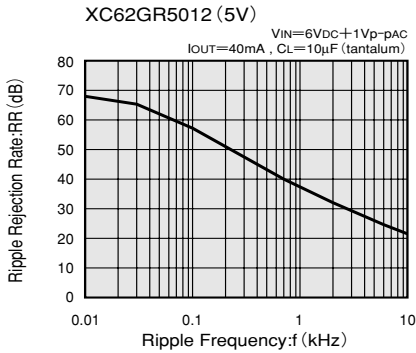

单击下面可查看定价，库存，交付和生命周期等信息

[>>Torex Semiconductor\(特瑞仕\)](#)