

## Electrostatic Discharged Protection Devices (ESD) Data Sheet

### Description

Brightking's UES08A03L05 component is surge rated diode array designed to protect high speed data line interfaces. It has been specifically designed to protect sensitive components which are connected to data and transmission lines from overvoltage caused by electrostatic discharge (ESD), electrical fast transients (EFT), and lightning. The unique design of this device incorporates surge rated, low capacitance steering diodes and TVS diodes in a single package. During transient conditions, the steering diodes direct the transient either the position side of the power supply or to the ground.



Contact : ±8kV  
Air : ±15kV



### Features

- IEC61000-4-2 ESD 15KV Air, 8KV contact compliance
- SOIC-08 surface mount package
- Protects four I/O lines and one power line
- Working voltage: 3.3V
- Low leakage current
- Low capacitance and clamping voltage
- Solid-state silicon avalanche technology
- Lead Free/RoHS compliant
- Solder reflow temperature: Pure Tin-Sn, 260~270°C
- Flammability rating UL 94V-0
- Meets MSL level 1, per J-STD-020
- Marking: B A035

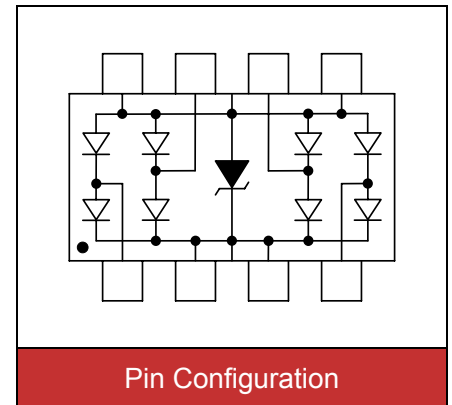

### Applications

- Ethernet 10/100/ base T
- Firewire & USB protection
- Set Top Box (STB) protection
- Video card (DVI) protection
- T1/E1 secondary IC side protection
- T3/E3 secondary IC side protection
- HDSL secondary IC side protection
- IC bus protection
- Micro-controller line protection

### Maximum Ratings

Rating	Symbol	Value	Unit
Peak pulse current (tp=8/20μs waveform)	I <sub>PP</sub>	25	A
ESD voltage (Contact discharge)	V <sub>ESD</sub>	±8	kV
ESD voltage (Air discharge)		±15	
Storage & operating temperature range	T <sub>STG</sub> , T <sub>J</sub>	-55~+150	°C

Electrical Characteristics (T<sub>J</sub>=25°C)

Parameter	Symbol	Condition	Min.	Typ.	Max.	Unit
Reverse stand-off voltage	V <sub>RWM</sub>				3.3	V
Reverse breakdown voltage	V <sub>BR</sub>	I <sub>BR</sub> =1mA	3.5			V
Reverse leakage current	I <sub>R</sub>	V <sub>R</sub> =3.3V Each I/O pin			1	μA
Clamping voltage (tp=8/20μs)	V <sub>C</sub>	I <sub>PP</sub> =1A		7.5		V
Clamping voltage (tp=8/20μs)	V <sub>C</sub>	I <sub>PP</sub> =5A		9.8		V
Clamping voltage (tp=8/20μs)	V <sub>C</sub>	I <sub>PP</sub> =25A		25		V
Off state junction capacitance	C <sub>J</sub>	0Vdc, f=1MHz Between I/O pins and GND			5	pF

Applications Information

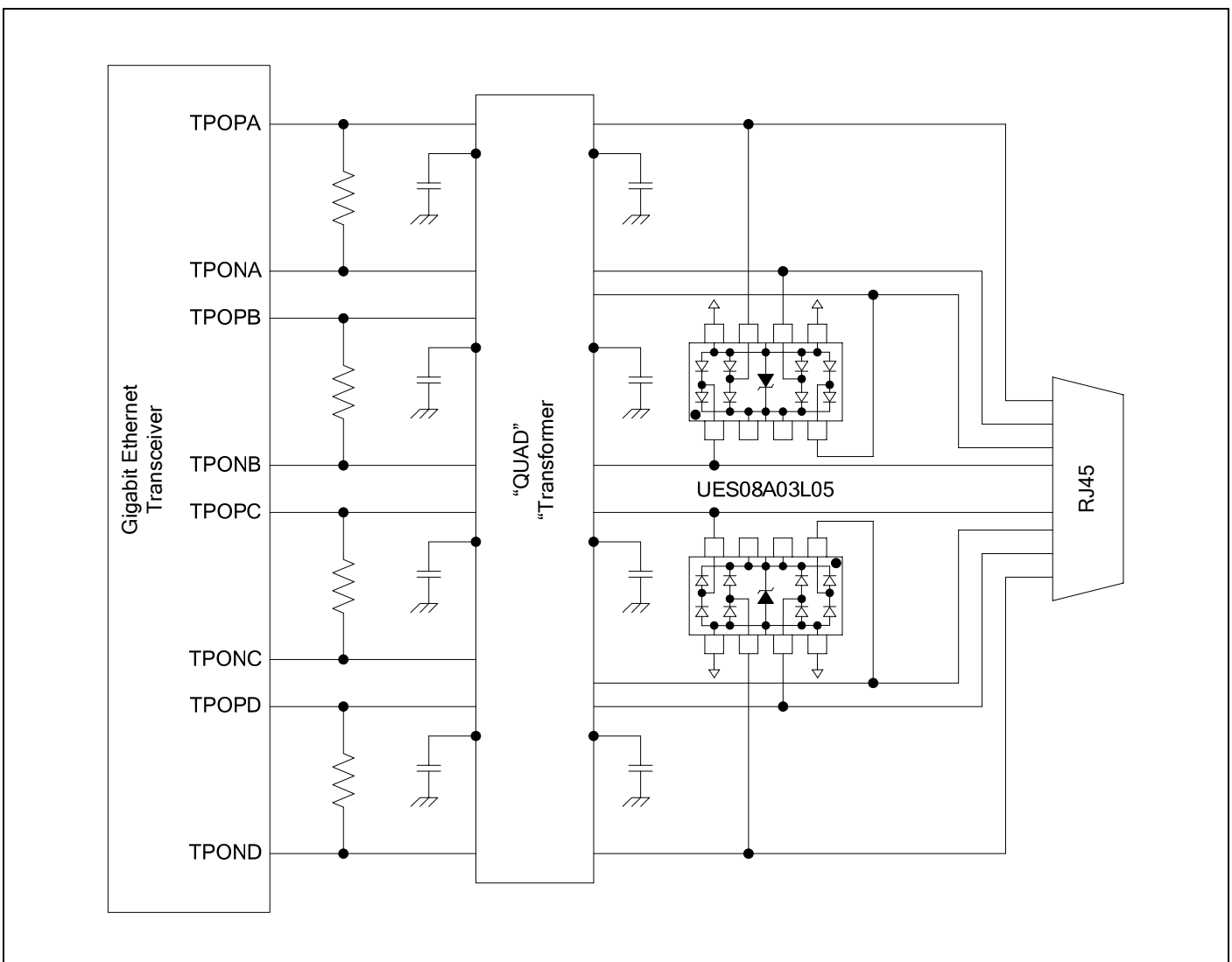

Typical Characteristics Curves

Figure 1. Pulse Waveforms

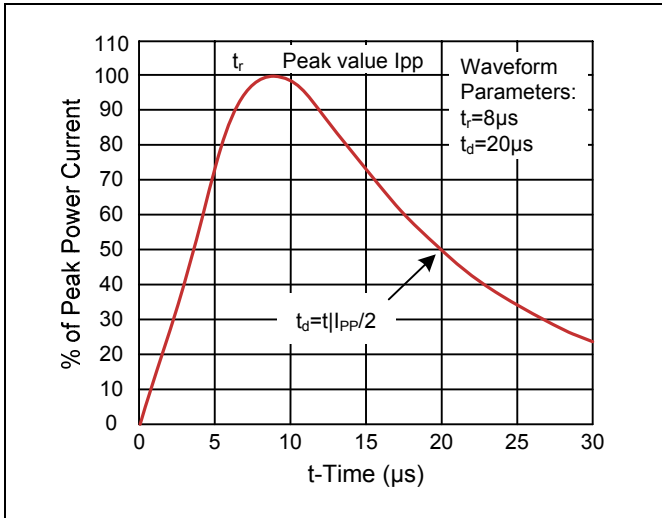

Figure 2. Clamping Voltage vs. Peak Pulse Current

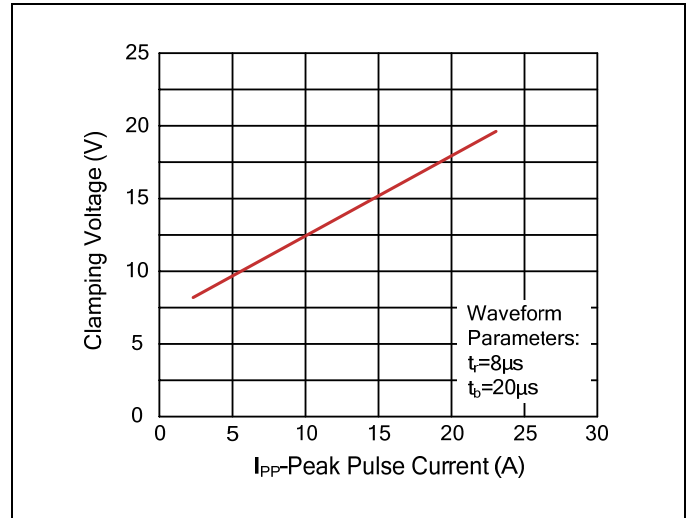
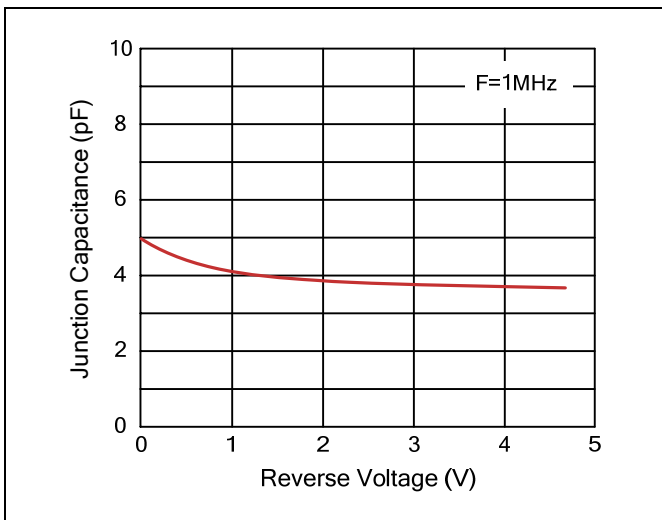
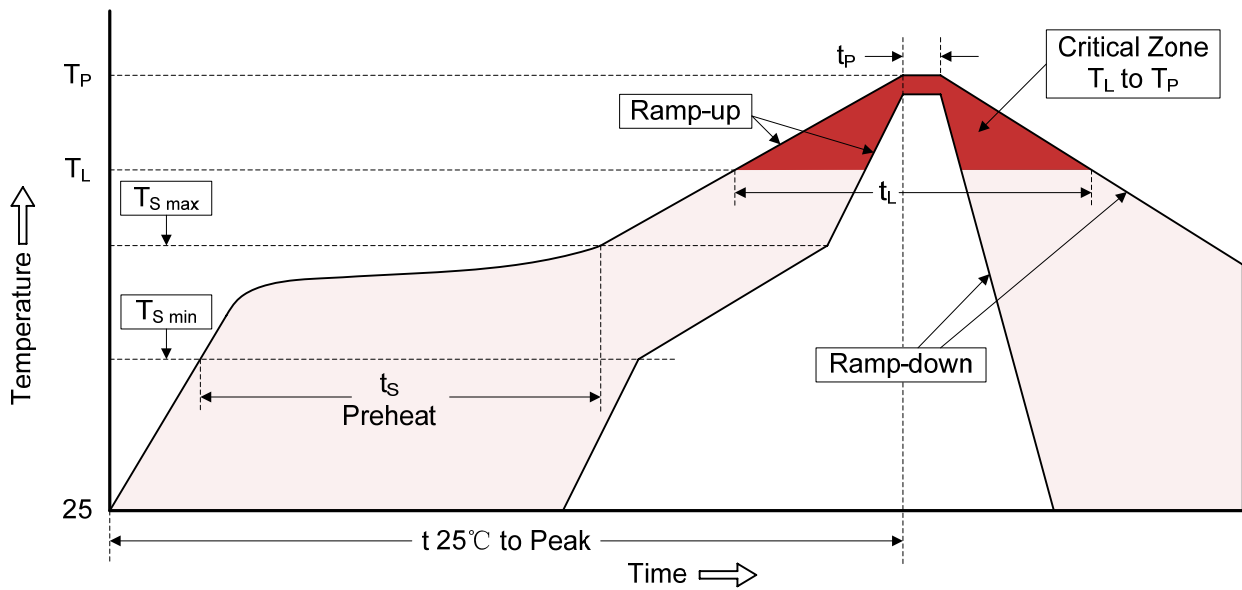

Figure 3. Capacitance vs. Reverse Voltage



**Recommended Soldering Conditions**

Reflow Soldering



Recommended Conditions

Profile Feature	Pb-Free Assembly
Average ramp-up rate ( $T_L$ to $T_P$ )	3°C/second max.
Preheat -Temperature Min ( $T_{S\ min}$ ) -Temperature Max ( $T_{S\ max}$ ) -Time (min to max) ( $t_s$ )	150°C 200°C 60-180 seconds
$T_{S\ max}$ to $T_L$ -Ramp-up Rate	3°C/second max.
Time maintained above: -Temperature ( $T_L$ ) -Time ( $t_L$ )	217°C 60-150 seconds
Peak Temperature ( $T_P$ )	260°C
Time within 5°C of actual Peak Temperature ( $t_p$ )	20-40 seconds
Ramp-down Rate	6°C/second max.
Time 25°C to Peak Temperature	8 minutes max.

Dimensions (SOIC-08)

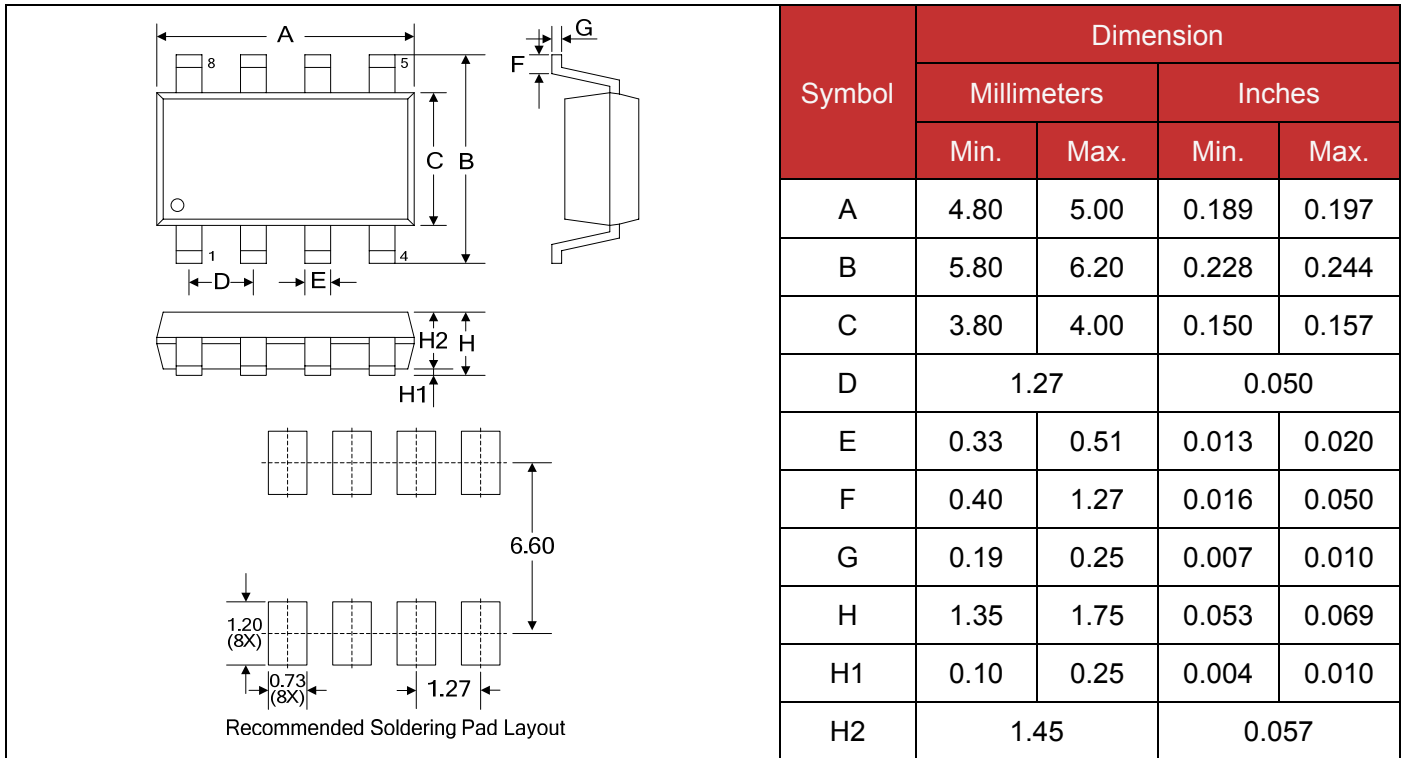

Packaging

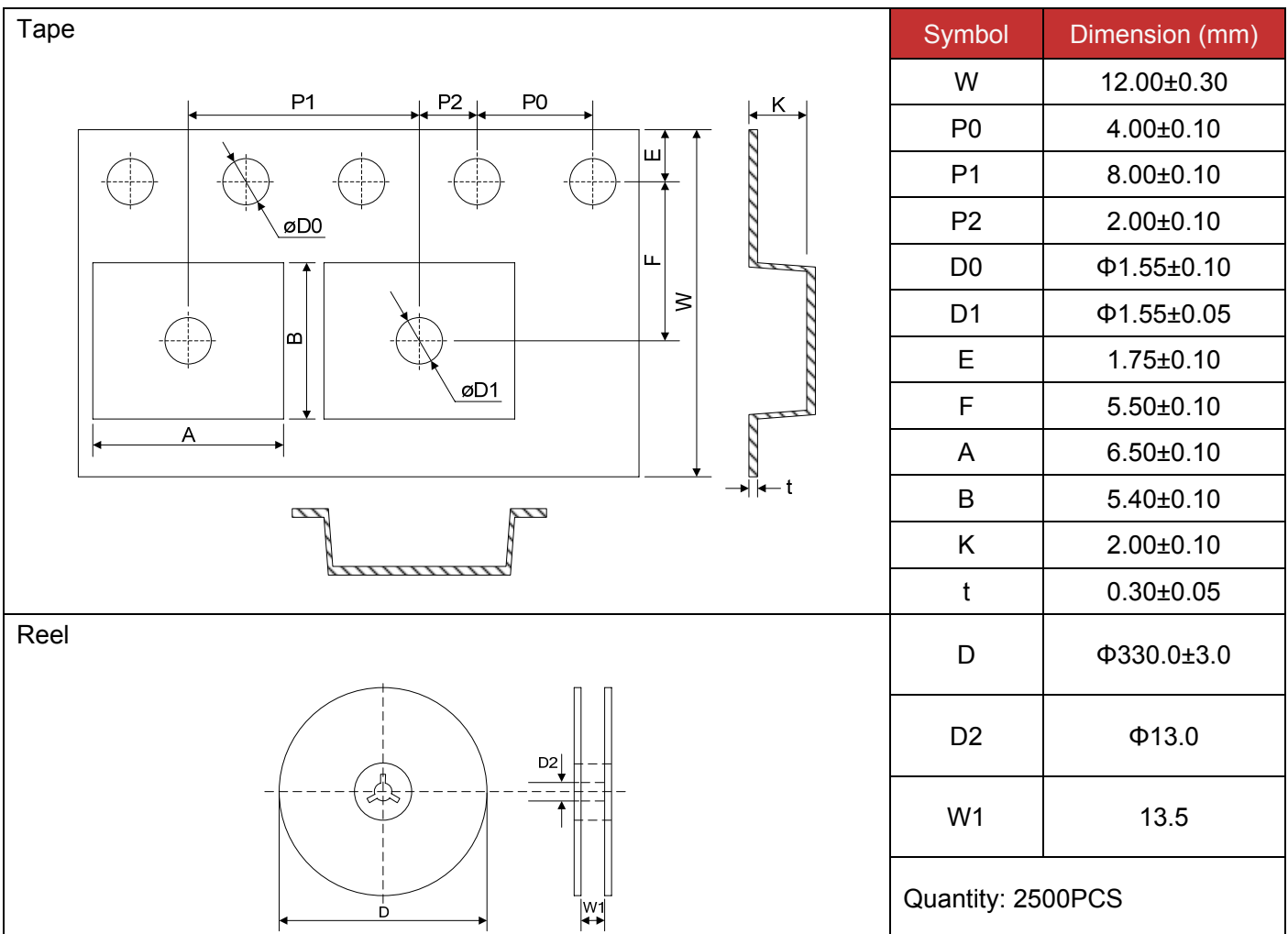

单击下面可查看定价，库存，交付和生命周期等信息

[>>Brightking\(君耀电子\)](#)