

### 3.4 mm×1.7 mm Side-operational Edge-mount Light Touch Switches

Type: **EVPAT**

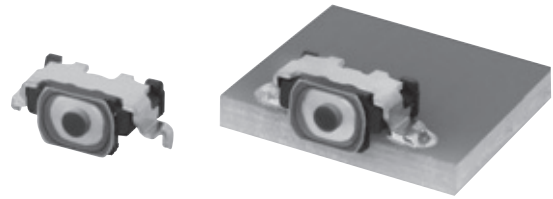

#### ■ Features

- External dimensions : 3.4 mm×1.7 mm (Excluding the push plate), Height 1.65 mm (The height from PCB surface : 1.105 mm)
- High operability  
Equipped with an actuator (push plate)
- IP67

#### ■ Recommended Applications

- Operation switches for portable electronic equipment  
(Mobile phones, Digital still cameras, Camcorders Portable audio players, etc.)

#### ■ Explanation of Part Numbers

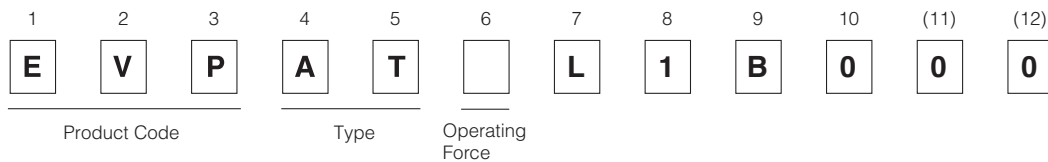

#### ■ Specifications

Type		Snap action/Push-on type SPST
Electrical	Rating	10 μA 2 V DC to 20 mA 15 V DC (Resistive load)
	Contact Resistance	500 mΩ max.
	Insulation Resistance	50 MΩ min. (at 100 V DC)
	Dielectric Withstanding Voltage	250 V AC for 1 minute
	Bouncing	10 ms max. (ON, OFF)
Mechanical	Operating Force	1.0 N , 1.6 N , 2.4N
	Travel	0.08 mm (1.0 N) , 0.11 mm (1.6 N , 2.4 N)
Endurance	Operating Life	500,000 cycles
Protective Structure		IP67(*1) Dust resistance : 4 types of talc 8 h, Water resistance : Immersion depth 1 m 30 min.
Operating Temperature		-40 °C to +85 °C
Storage Temperature		-40 °C to +85 °C (Bulk) -20 °C to +60 °C (Taping)
Minimum Quantity/Packing Unit		10,000 pcs. Embossed Taping (Reel Pack)
Quantity/Carton		50,000 pcs.

Note: Non washable

(\*1) IP67 : Switch shall not be operated during test.

Water or dust ingress shall be limited enough to prevent deleterious effect to the switch function.





However, IP67 shall be guaranteed under single product state,

then there is a possibility that IP67 performance become impaired depending on your mounting condition or usage.

So, please ask us in advance, if the switch is applied to important usage for water and dust resistant.

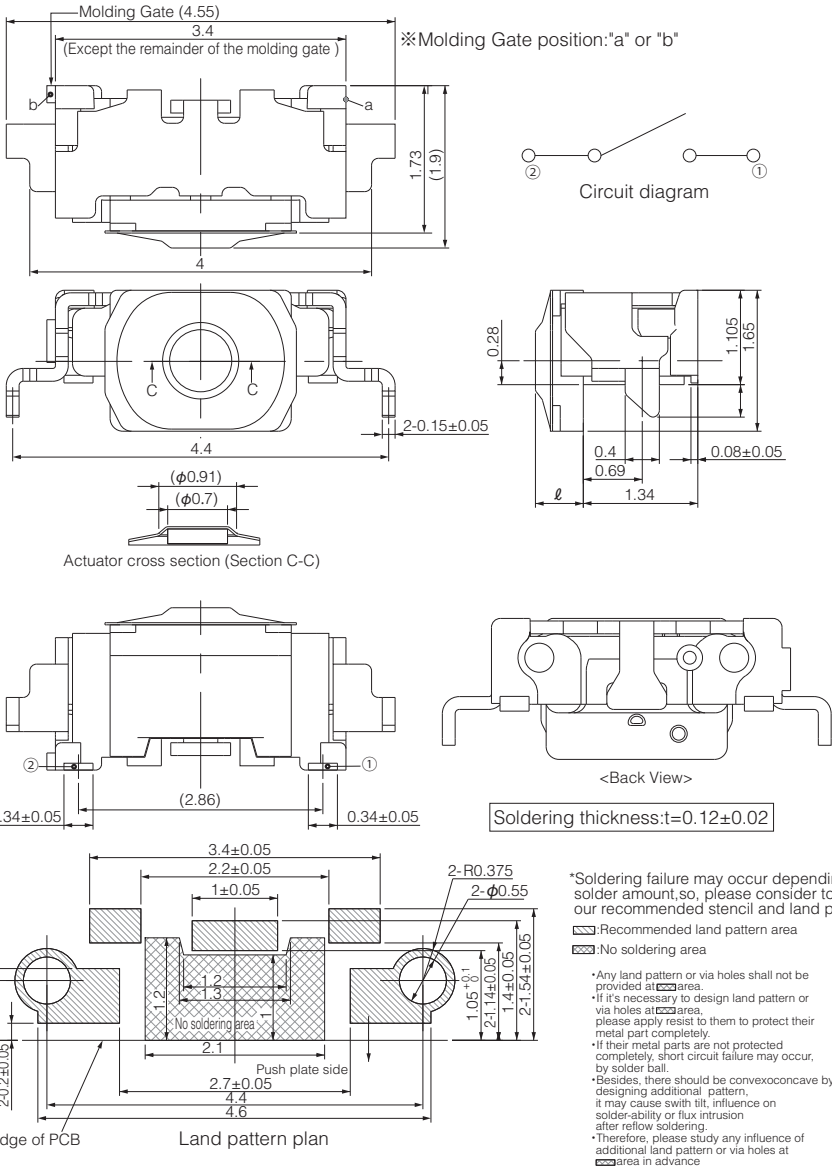
Design and specifications are each subject to change without notice. Ask factory for the current technical specifications before purchase and/or use.  
Should a safety concern arise regarding this product, please be sure to contact us immediately.

### ■ Dimensions in mm (not to scale)

<p>EVPAT (Embossed Taping)</p>	<p>General dimension tolerance : <math>\pm 0.1</math> ( ) dimensions are reference dimensions.</p>			
	 <p>※Molding Gate position: "a" or "b"</p> <p>Circuit diagram</p> <p>Actuator cross section (Section C-C)</p> <p>&lt;Back View&gt;</p> <p>Soldering thickness: <math>t=0.12\pm 0.02</math></p> <p>Land pattern plan</p> <p>Edge of PCB</p> <p>Push plate side</p> <p>No soldering area</p> <p>Recommended land pattern area</p> <p>No soldering area</p> <p>*Soldering failure may occur depending on applied solder amount, so, please consider to use our recommended stencil and land pattern desing</p> <ul style="list-style-type: none"> <li>Any land pattern or via holes shall not be provided at  area.</li> <li>If it's necessary to design land pattern or via holes at  area, please apply resist to them to protect their metal part completely.</li> <li>If their metal parts are not protected completely, short circuit failure may occur, by solder ball.</li> <li>Besides, there should be convex/concave by designing additional pattern, it may cause switch tilt, influence on solder-ability or flux intrusion after reflow soldering.</li> <li>Therefore, please study any influence of additional land pattern or via holes at  area in advance</li> </ul>			
Part Numbers	Operating Force	$l$ =The length from PCB edge to tip of Push plate	Height	Operating Life
EVPAT1L1B000	1.0 N	0.53 mm	1.105 mm	500,000 cycles
EVPAT2L1B000	1.6 N	0.56 mm	1.105 mm	500,000 cycles
EVPATAL1B000	2.4 N	0.585 mm	1.105 mm	500,000 cycles

Design and specifications are each subject to change without notice. Ask factory for the current technical specifications before purchase and/or use. Should a safety concern arise regarding this product, please be sure to contact us immediately.

## ■ Recommended Reflow Soldering Conditions

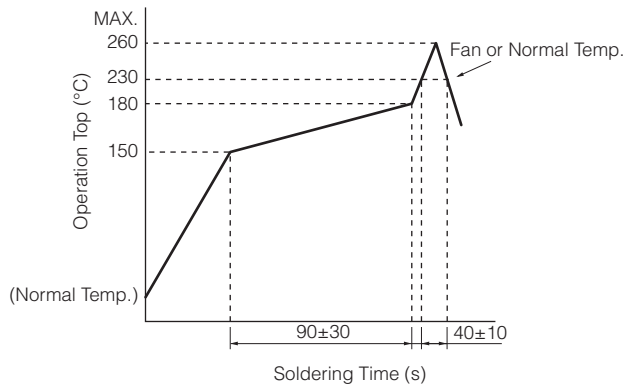

\* Reflow temperature may vary by location even in the same reflow condition. Please check the reflow temperature at terminals and at the top of a switch to make sure the both temperatures are within the specification. If even one of them is out of the specifications, please adjust.

## ● Embossed Carrier Taping

Tape width=12.0 mm (A=12.0 mm)

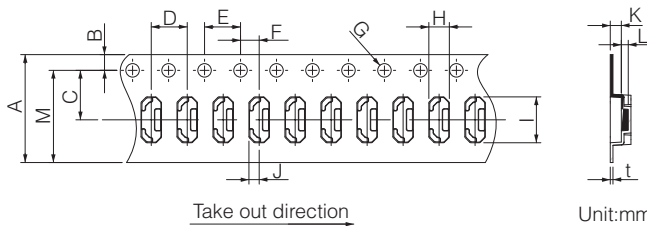

Taping condition : Lack of products in the middle of taping should be one MAX, but total quantity specified in the specifications should be secured.  
 Peeling off strength of top tape : It should be within 0.2N to 1.0N at 165 degree in peeling off angle.  
 Joint of carrier tape : One joint per one reel may exist.

Unit:mm

Part No.	Height	A	B	C	D	E	F	G	H	I	J	K	L	M	Unit: mm	
															t	
EVPAT	1.105	12.0±0.2	1.75±0.10	5.50±0.05	4.0±0.1	4.0±0.1	2.00±0.05	1.5 <sup>+0.1</sup>	2.28±0.20	4.8±0.2	(1.065)	1.23±0.10	0.77±0.10	(10.25)	0.30±0.05	

## Requests to customers

Please refer to "the latest product specifications" when designing your product.

Requests to customers :

<https://industrial.panasonic.com/ac/e/salespolicies/>

## Safety Precautions

When using our products, no matter what sort of equipment they might be used for, be sure to confirm the applications and environmental conditions with our specifications in advance.

Please contact .....

**Panasonic Corporation**

Electromechanical Control Business Division

■ 1006, Oaza Kadoma, Kadoma-shi, Osaka 571-8506, Japan  
[industrial.panasonic.com/ac/e/](https://industrial.panasonic.com/ac/e/)

**Panasonic**<sup>®</sup>

©Panasonic Corporation 2019

单击下面可查看定价，库存，交付和生命周期等信息

[>>Panasonic\(松下\)](#)