



CH-101 Datasheet

CH-101 Datasheet

GENERAL INFORMATION

The CH-101 is a miniature, ultra-low-power ultrasonic Time-of-Flight (ToF) range sensor. Based on Chirp's patented MEMS technology, the CH-101 is a system-in-package that integrates a PMUT (piezoelectric micromachined ultrasonic transducer) together with an ultra-low-power SoC (system on chip) in a miniature, reflowable package. The SoC runs Chirp's advanced ultrasonic DSP algorithms and includes an integrated microcontroller that provides digital range readings via I²C.

Complementing Chirp's other ultrasonic ToF sensor products, the CH-101 provides accurate range measurements to targets at distances up to 1.2 m. Using ultrasonic pulse-echo measurements, the sensor works in any lighting conditions, including full sunlight, and provides millimeter-accurate range measurements independent of the target's color and optical transparency. The sensor's wide Field-of-View (FoV) enables simultaneous range measurements to multiple objects in the FoV.

DEVICE INFORMATION

PART NUMBER	PACKAGE	LID OPENING
CH-101	3.5 x 3.5 x 1.26mm LGA	1-Hole

RoHS and Green-Compliant Package



APPLICATIONS

- Augmented and Virtual Reality
- Drones and Robotics
- Mobile and Computing Devices
- Obstacle avoidance
- Printers and Scanners
- Proximity sensing
- Presence detection: always-on sensing to lock/unlock and power on/off notebooks, tablets, white goods, etc.
- Smart Home

FEATURES

- Fast, accurate range-finding
 - Operating range from 4 cm to 1.2 m
 - Sample rate up to 100 samples/sec
 - 1.0 mm RMS range noise at 30 cm range
 - Programmable modes optimized for medium and short-range sensing applications
 - Customizable field of view (FoV) up to 180°
 - Multi-object detection
 - Works in sunlight and any other lighting
 - Insensitive to object color, detects optically transparent surfaces like glass windows
- Easy to integrate
 - Single sensor for receive and transmit
 - Single 1.8V supply
 - I²C Fast-Mode compatible interface, data rates up to 400 kbps
 - Dedicated programmable range interrupt pin
 - Platform-independent software driver enables turnkey range-finding
- Miniature integrated module
 - Compatible with standard SMD reflow
 - Low-power micro-controller running advanced ultrasound firmware
 - Operating temperature range: -40°C to 85°C
- Ultra-low supply current
 - 1 sample/s:
 - 13 μA (10 cm max range)
 - 15 μA (1.0 m max range)
 - 30 samples/s:
 - 33 μA (10 cm max range)
 - 130 μA (1.0 m max range)

TABLE OF CONTENTS

GENERAL INFORMATION..... 2

DEVICE INFORMATION 2

APPLICATIONS 2

FEATURES..... 2

1 SPECIFICATION..... 5

2 PART NUMBERING 6

3 CH-101 PINOUT 7

4 TYPICAL OPERATING CIRCUIT 8

5 THEORY OF OPERATION 9

6 CHIRP CH-101 DRIVER 10

7 INTERFACING TO THE CH-101..... 11

8 DEVICE MODES OF OPERATION 12

 8.1 FREE-RUNNING MODE 12

 8.2 HARDWARE TRIGGERED MODE 12

 8.3 STANDBY MODE 12

9 PACKAGE 13

 9.1 PACKAGE DIMENSIONS 13

 9.2 PACKAGE MARKING 13

10 RECOMMENDED PCB FOOTPRINT 14

11 TAPE & REEL SPECIFICATION 15

12 SHIPPING LABEL 16

13 SHIPPING PACKAGE..... 17

14 RELATED DOCUMENTS 19

15 REVISION HISTORY 20

LIST OF FIGURES

Figure 1. 8-Pin Diagram 7

Figure 2. Single Transceiver Operation 8

Figure 3. Multiple Transceiver Operation 8

Figure 4. CH-101 Block Diagram..... 9

Figure 5. CH-101 I²C Slave Interface 11

Figure 6. CH-101 Dimensions..... 13

Figure 7. CH-101 Marking 13

Figure 8. CH-101 Recommended PCB Footprint 14

Figure 9. CH-101 Tape and Reel Specification 15

Figure 10. Shipping Label 16

Figure 11. Tape and Reel Shipping Bag 17

Figure 12. Tape and Reel Shipping Bag Contents..... 17

Figure 13. Shipping Inner Box 17

Figure 14. Shipping Inner Box Label..... 18

LIST OF TABLES

Table 1. Specifications 5

Table 2. Pin Summary 7

1 SPECIFICATION

Test conditions: $V_{DD} = 1.8\text{ V}$, $T = 25^{\circ}\text{C}$, General Purpose Rangefinder (GPR) firmware image loaded, stationary target rejection disabled.

Package	8 pin LGA
Size	3.5 x 3.5 x 1.26 mm
Operating voltage	1.62 V to 1.98 V
Operating temperature	-40°C to 85°C
I²C	7-bit addressing 400 kHz Fast-mode
Typical current consumption (Range finding mode)	1 sample/sec: 13 μA (10 cm max range) 15 μA (1.0 m max range) 30 samples/sec: 33 μA (10 cm max range) 130 μA (1.0 m max range)
Operating Range	4 cm* to 1.2 m
Range Noise	1.0 mm RMS (@ 30cm in range)
Measuring Rate	Up to 100 samples/sec
Field of View	Up to 180°
Latency	1 ms (10 cm max range) 10 ms (1 m max range)
Programming time	60 ms

*For non-stationary objects.

**For optimum device performance the acoustic port must be open and clear of obstructions.

Table 1. Specifications

2 PART NUMBERING

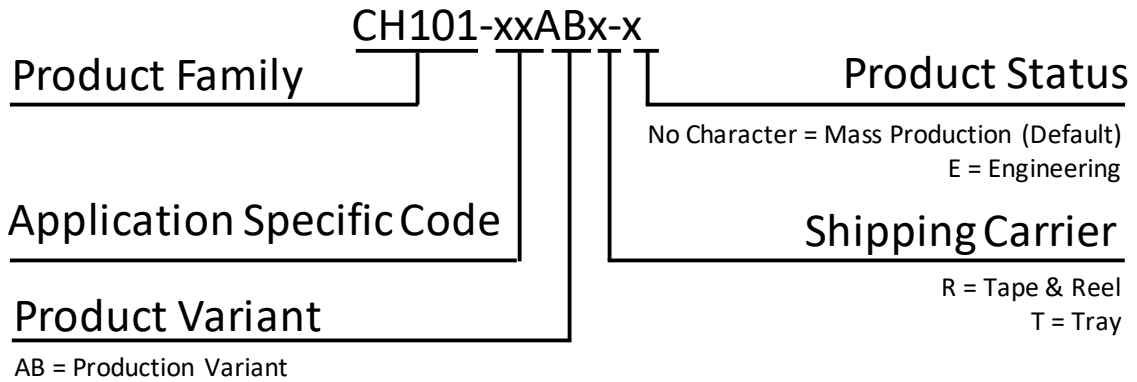

This datasheet specifies the following part numbers

Part Number
CH101-00ABx-x
CH101-01ABx-x
CH101-02ABx-x
CH101-03ABx-x
CH101-04ABx-x
CH101-05ABx-x

3 CH-101 PINOUT

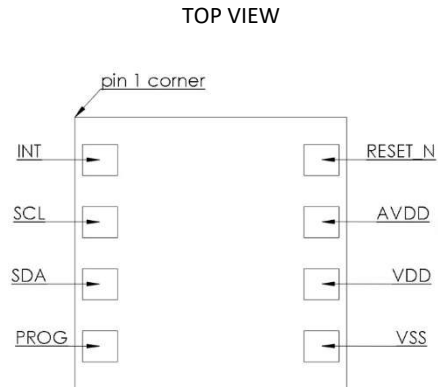

Figure 1. 8-Pin Diagram

PIN NUMBER	NAME	DESCRIPTION
1	INT	Interrupt output. Can be switched to input for trigger and calibration functions.
2	SCL	I ² C Clock. This pin must be pulled up externally.
3	SDA	I ² C Data. This pin must be pulled up externally.
4	PROG	Program enable. Cannot be floating.
5	VSS	Connect to Ground
6	VDD	Digital power
7	AVDD	Analog power
8	RESET_N	Active-low reset. Cannot be floating.

Table 2. Pin Summary

4 TYPICAL OPERATING CIRCUIT

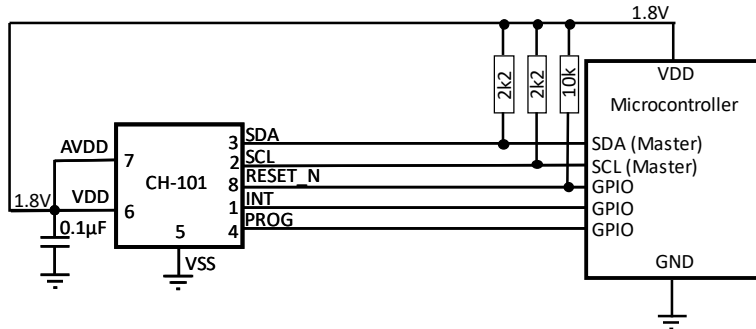

Figure 2. Single Transceiver Operation

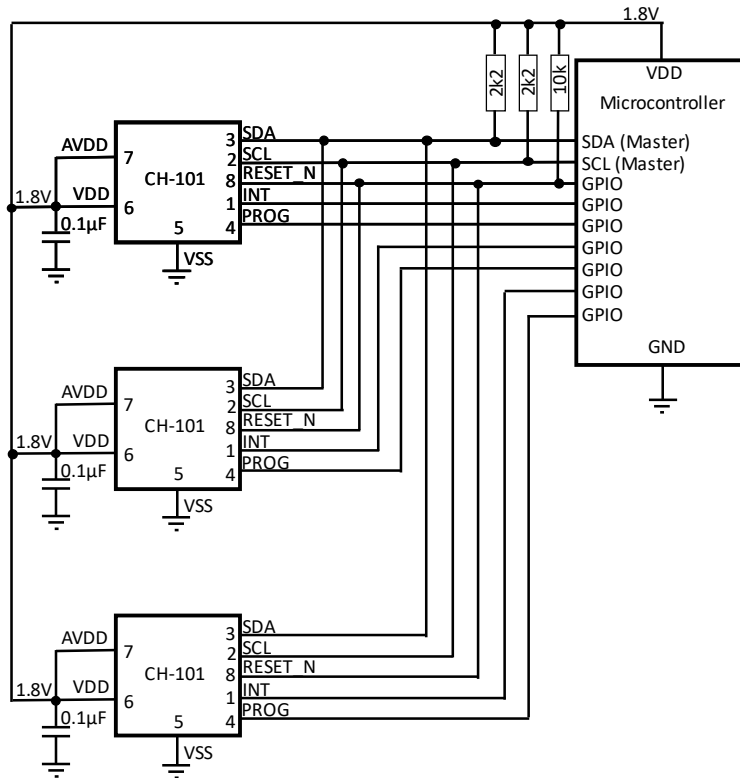

Figure 3. Multiple Transceiver Operation

5 THEORY OF OPERATION

The CH-101 is an autonomous, digital output ultrasonic rangefinder. Figure 4 shows the package-level block diagram. Inside the package are a micromachined ultrasonic transducer (MUT) and application specific integrated circuit (ASIC). The MUT produces pulses of ultrasound that reflect off targets in the transceiver’s field-of-view (FoV). The reflections are picked up by the same MUT after a short time delay, amplified by sensitive electronics, digitized, and further processed to produce the range to the primary target.

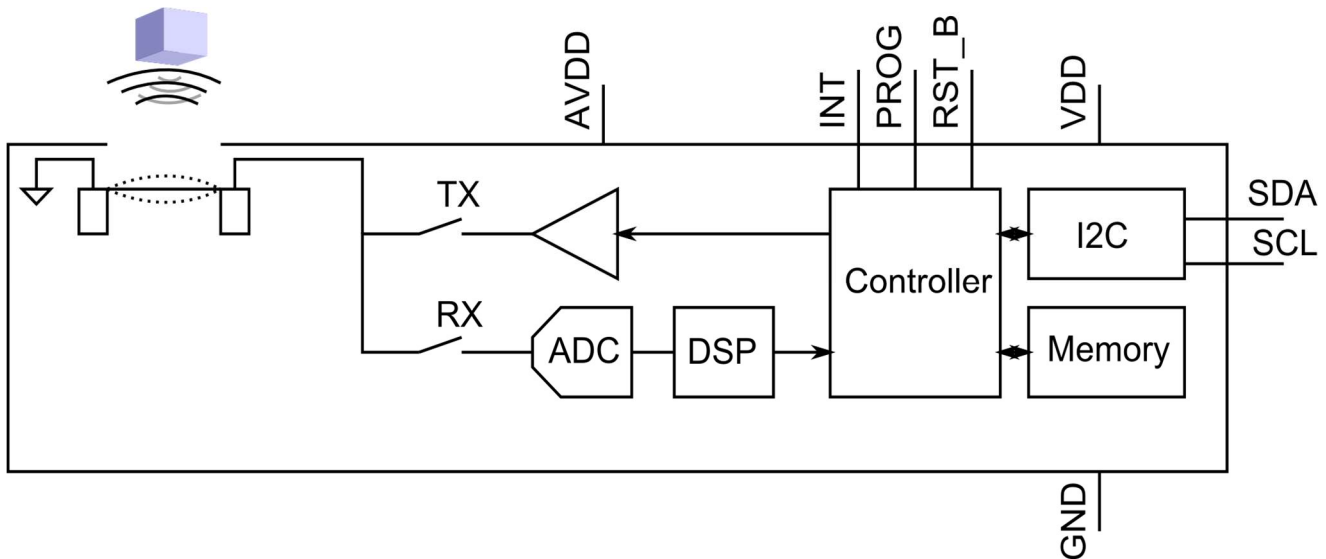

Figure 4. CH-101 Block Diagram

The time it takes the ultrasound pulse to propagate from the sensor to the target and back is called the time-of-flight. The distance to the target is found by multiplying the time-of-flight by the speed of sound and dividing by two (to account for the round-trip). The speed of sound in air is approximately 343 m/s. The speed of sound is not a constant but is generally stable enough to give measurement accuracies within a few percent error.

A time-of-flight ultrasonic rangefinder has several advantages over more common IR intensity-based transceivers. The range measurement is not sensitive to the size, color, or reflectivity of the target and the transceiver is insensitive to ambient light. Additionally, a maximum range of up to 1.2 m is supported, and the power consumption is up to several orders of magnitude lower than that of IR proximity transceivers.

A CH-101 program file must be loaded into the on-chip memory at initial power-on. The program, or firmware, is loaded through a special I²C interface. Chirp provides a default general-purpose rangefinder (GPR) firmware that is suitable for a wide range of applications. This firmware enables autonomous range finding operation of the CH-101. It also supports hardware-triggering of the CH-101 for applications requiring multiple transceivers. Program files can also be tailored to the customer’s application. Contact Chirp for more information.

CH-101 has several features that allow for low power operation. An ultra-low-power, on-chip real-time clock (RTC) sets the sample rate and provides the reference for the time-of-flight measurement. The host processor does not need to provide any stimulus to the CH-101 during normal operation, allowing the host processor to be shut down into the lowest power mode until the CH-101 generates a wake-up interrupt. There is also a general-purpose input/output (INT) pin that can be used as a system wake-up source. The interrupt pin can be configured to trigger on motion or proximity.

6 CHIRP CH-101 DRIVER

Chirp provides a compiler/device independent C driver for the CH-101 which greatly simplifies integration. The CH-101 driver implements high-level control of one or more CH-101s attached to one or more I²C ports on the host processor. The CH-101 driver allows the user to program, configure, trigger, and readout data from the CH-101 through use of C function calls without direct interaction with the CH-101 I²C registers. The CH-101 driver only requires the customer to implement an I/O layer which communicates with the host processor's I²C hardware and GPIO hardware. Chirp highly recommends that all new designs use the CH-101 driver.

7 INTERFACING TO THE CH-101

The CH-101 communicates with a host processor over the 2-wire I²C protocol. The CH-101 operates as an I²C slave and responds to commands issued by the I²C master.

The CH-101 contains two separate I²C interfaces, running on two separate slave addresses. The first is for loading firmware into the on-chip program memory, and the second is for in-application communication with the CH-101. The programming address is 0x45, and the application address default is 0x29. The application address can be reprogrammed to any valid 7-bit I²C address.

The CH-101 uses clock stretching to allow for enough time to respond to the I²C master. The CH-101 clock stretches before the acknowledge (ACK) bit on both transmit and receive. For example, when the CH-101 transmits, it will hold SCL low after it transmits the 8th bit from the current byte while it loads the next byte into its internal transmit buffer. When the next byte is ready, it releases the SCL line, reads the master's ACK bit, and proceeds accordingly. When the CH-101 is receiving, it holds the SCL line low after it receives the 8th bit in a byte. The CH-101 then chooses whether to ACK or NACK depending on the received data and releases the SCL line.

Figure 5 shows an overview of the I²C slave interface. In the diagram, 'S' indicates I²C start, 'R/W' is the read/write bit, 'Sr' is a repeated start, 'A' is acknowledge, 'P' is the stop condition. Grey boxes indicate the I²C master actions; white boxes indicate the I²C slave actions.

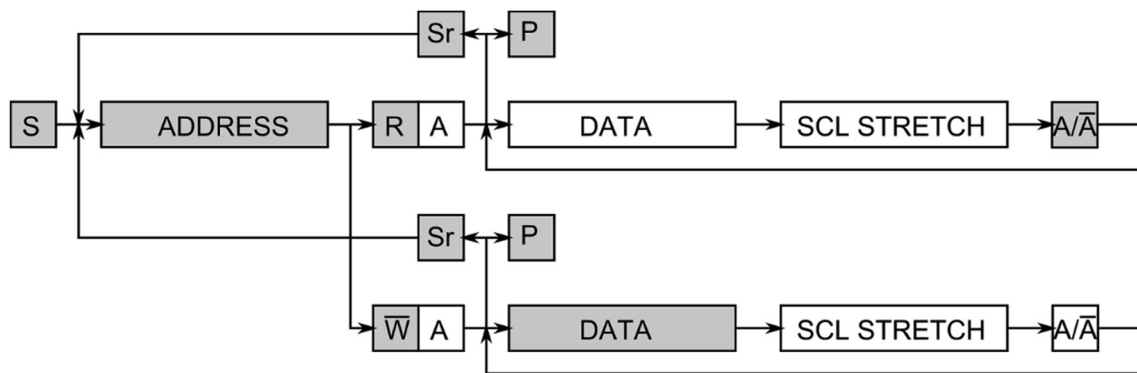

Figure 5. CH-101 I²C Slave Interface

8 DEVICE MODES OF OPERATION

8.1 FREE-RUNNING MODE

In the free-running measurement mode, the CH-101 runs autonomously at a user specified sample rate. In this mode, the INT pin is configured as an output. The CH-101 pulses the INT pin high when a new range sample is available. At this point, the host processor may read the sample data from the CH-101 over the I²C interface.

8.2 HARDWARE TRIGGERED MODE

In the hardware triggered mode, the INT pin is used bi-directionally. The CH-101 remains in an idle condition until triggered by pulsing the INT pin. The measurement will start with sub-microsecond latency relative to the rising edge on INT. This mode is most useful for synchronizing several CH-101 transceivers. The host controller can use the individual INT pins of several transceivers to coordinate the exact timing.

8.3 STANDBY MODE

The recommended way to put the CH-101 into low power standby mode is to use the free-running mode with PERIOD=0 and TICK_INTERVAL=2048.

9 PACKAGE

9.1 PACKAGE DIMENSIONS

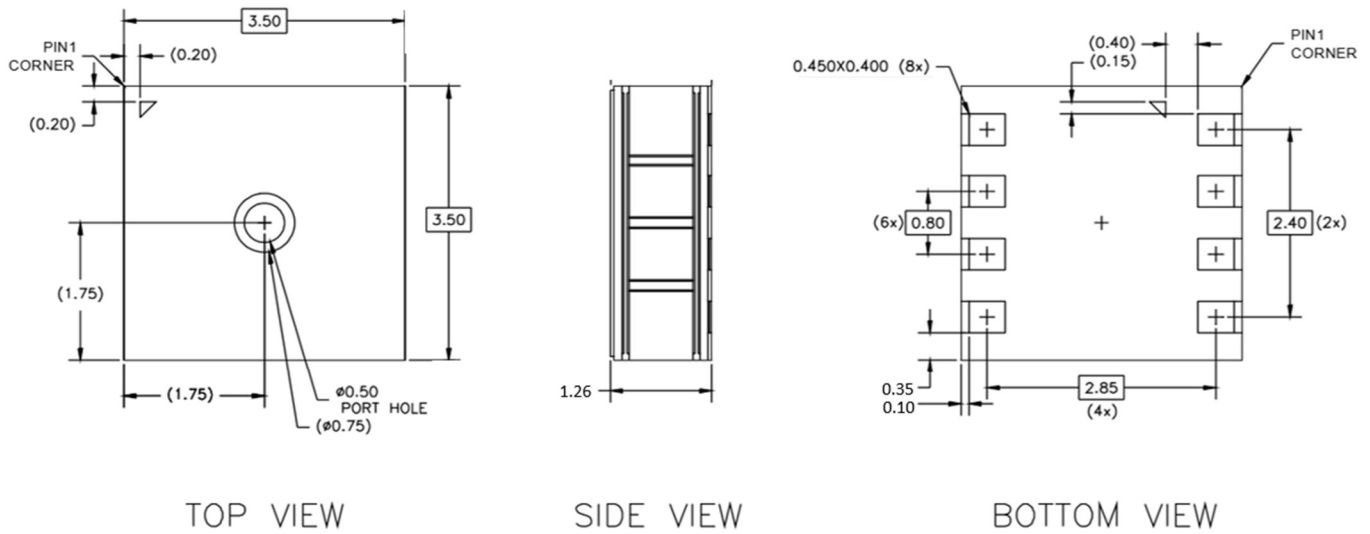

Figure 6. CH-101 Dimensions

9.2 PACKAGE MARKING

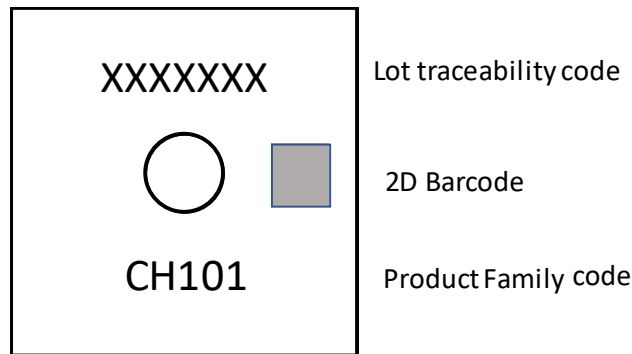

Figure 7. CH-101 Marking

10 RECOMMENDED PCB FOOTPRINT

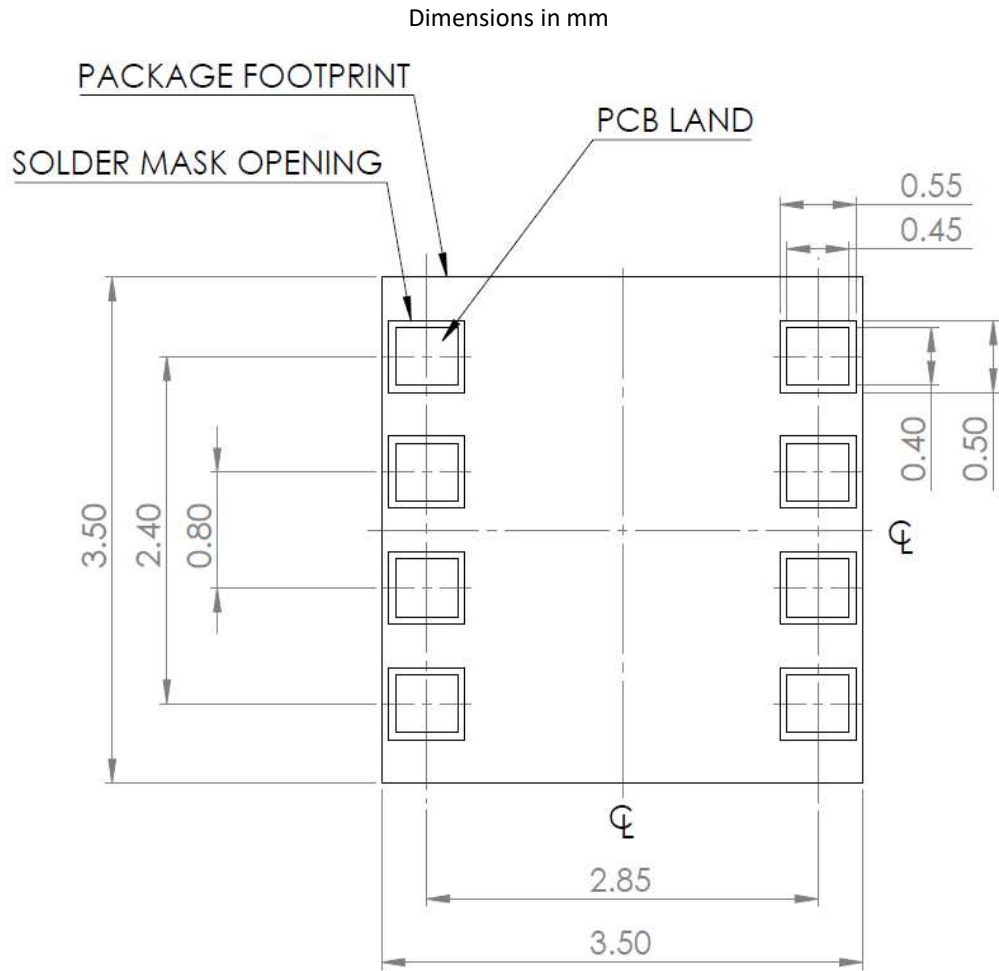

Figure 8. CH-101 Recommended PCB Footprint

11 TAPE & REEL SPECIFICATION

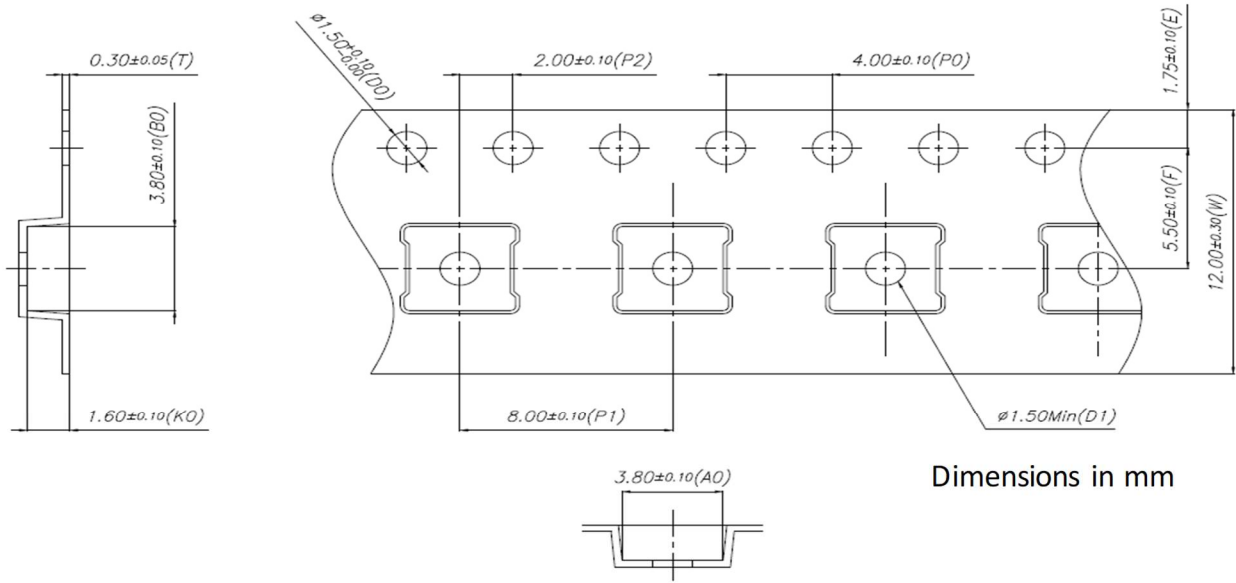

Figure 9. CH-101 Tape and Reel Specification

Reel size is 1000 units, Minimum Order Quantity (MOQ) is 1000 units and in multiples of 1000 units.

12 SHIPPING LABEL

A Shipping Label will be attached to the reel, bag and box. The information provided on the label is as follows:

Device: This is the full part number

Lot Number: Chirp manufacturing lot number

Date Code: Date the lot was sealed in the moisture proof bag

Quantity: Number of components on the reel

2D Barcode: Contains Lot No., quantity and reel/bag/box number



Figure 10. Shipping Label

13 SHIPPING PACKAGE



Figure 11. Tape and Reel Shipping Bag

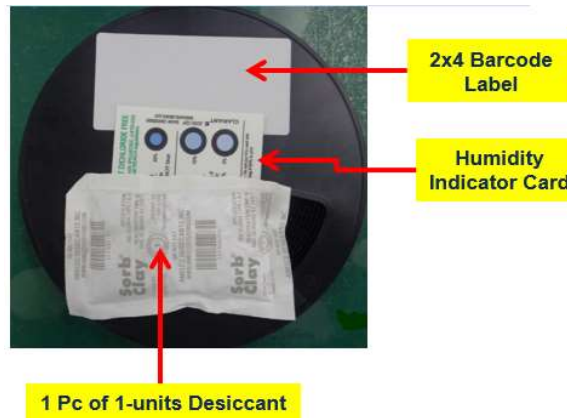

Figure 12. Tape and Reel Shipping Bag Contents

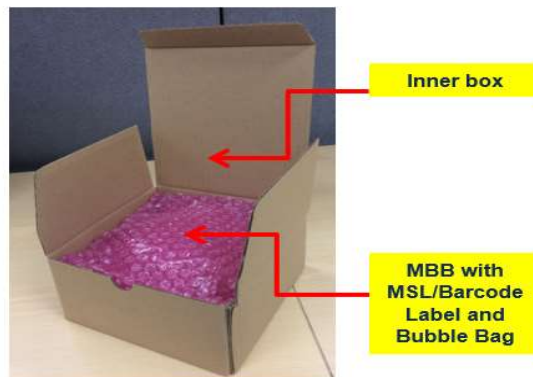

Figure 13. Shipping Inner Box

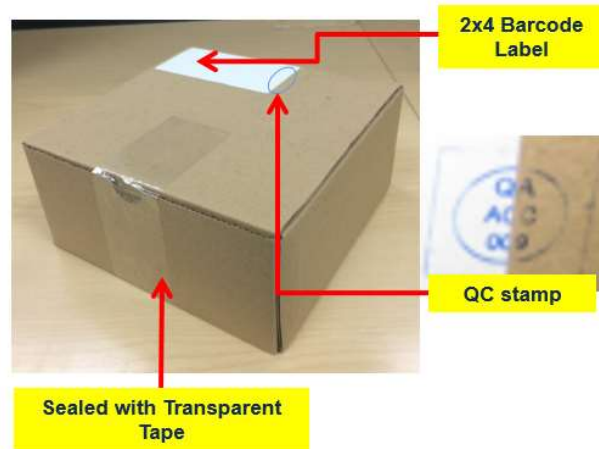

Figure 14. Shipping Inner Box Label

14 RELATED DOCUMENTS

- AN-000158 CH-101 Mechanical Integration Guide
- AN-000159 Handling and Assembly Guide

15 REVISION HISTORY

Revision Date	Revision	Description
09/30/2019	1.0	Initial Release

This information furnished by Chirp Microsystems, Inc. ("Chirp Microsystems") is believed to be accurate and reliable. However, no responsibility is assumed by Chirp Microsystems for its use, or for any infringements of patents or other rights of third parties that may result from its use. Specifications are subject to change without notice. Chirp Microsystems reserves the right to make changes to this product, including its circuits and software, in order to improve its design and/or performance, without prior notice. Chirp Microsystems makes no warranties, neither expressed nor implied, regarding the information and specifications contained in this document. Chirp Microsystems assumes no responsibility for any claims or damages arising from information contained in this document, or from the use of products and services detailed therein. This includes, but is not limited to, claims or damages based on the infringement of patents, copyrights, mask work and/or other intellectual property rights.

Certain intellectual property owned by Chirp Microsystems and described in this document is patent protected. No license is granted by implication or otherwise under any patent or patent rights of Chirp Microsystems. This publication supersedes and replaces all information previously supplied. Trademarks that are registered trademarks are the property of their respective companies. Chirp Microsystems sensors should not be used or sold in the development, storage, production or utilization of any conventional or mass-destructive weapons or for any other weapons or life threatening applications, as well as in any other life critical applications such as medical equipment, transportation, aerospace and nuclear instruments, undersea equipment, power plant equipment, disaster prevention and crime prevention equipment.

©2019 Chirp Microsystems. All rights reserved. Chirp Microsystems and the Chirp Microsystems logo are trademarks of Chirp Microsystems, Inc. The TDK logo is a trademark of TDK Corporation. Other company and product names may be trademarks of the respective companies with which they are associated.



©2019 Chirp Microsystems. All rights reserved.

单击下面可查看定价，库存，交付和生命周期等信息

[>>CHIRP](#)