



**TXC CORPORATION**

4F, NO. 16, Sec. 2 Chung Yang S Rd., Peitou, Taipei, Taiwan.

TEL : 886-2-2894-1202 , 886-2-2895-2201 FAX : 886-2-2894-1206 , 886-2-2895-6207

www.txccorp.com

# SPECIFICATION FOR APPROVAL

CUSTOMER : \_\_\_\_\_

PRODUCT TYPE : SMD SEAM SEALING CXO 7.0x5.0

NOMINAL FREQ. : 48.000000MHz

TXC P/N : 7W48000032

REVISION : A6

CUSTOMER P/N : \_\_\_\_\_

PM / SALES : \_\_\_\_\_

DATE : \_\_\_\_\_

CUSTOMER SIGNATURE & Date \_\_\_\_\_

- (1) TXC requires one copy returned with signature and title of authorized individual that signifies acceptance of the attached specifications.
- (2) Orders received and accepted by TXC after return of signed copy of specification will be produced per these specifications.
- (3) Any changes to these specifications must be agreed upon by both parties and new revision of the Product Specification Sheet will be issued.
- (4) Any issuance of purchase order prior to consigning back the Approval page of "Specification Sheets" from customers will be regarded as the agreement on the contents of these specifications.

Attachment: Product Specification Sheet

- 1
- 2
- 3
- 4
- 5

**RoHS Compliant**

# PRODUCT SPECIFICATION SHEET

PRODUCT TYPE : SMD SEAM SEALING CXO 7.0x5.0

---

NOMINAL FREQ. : 48.000000MHz



---

TXC P/N : 7W48000032

---

REVISION : A6

---

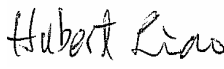
PE/RD	QA	MFG
		
10-Nov-09	10-Nov-09	10-Nov-09

**NOTE:**

- (1)Lead Free Products are "Directive 2002/95/EC of The European Parliament of 27 January 2003 on the restriction of the use of certain hazardous substances (RoHS) in electrical and electronic equipment" Compliant (Attachment: SGS Test Report).
- (2)Revision "Sx" is for engineering samples only. PE/RD's approval required.
- (3)Revision "Ax" is production ready. PE, QA and MFG's approval required.

**RoHS Compliant**



## ■ ELECTRICAL SPECIFICATIONS

### Standard atmospheric conditions

Unless otherwise specified, the standard range of atmospheric conditions for making measurement and tests are as follow:

Ambient temperature :  $25 \pm 5^{\circ}\text{C}$   
 Relative humidity : 40%~70%

If there is any doubt about the results, measurement shall be made within the following limits:

Ambient temperature :  $25 \pm 3^{\circ}\text{C}$   
 Relative humidity : 40%~70%

### Measure equipment

Electrical characteristics measured by MD 37WX-05M or equivalent.

### Crystal cutting type

The crystal is using AT CUT (thickness shear mode).

### Unit Weight:

0.152±0.001 g/pcs

	Parameters	SYM.	Electrical Spec.				Notes
			MIN	TYPE	MAX	UNITS	
1	Nominal Frequency	-	48.000000			MHz	-
2	Frequency Stability	-	±50			ppm	-
3	Operating Temperature	Topr	-10	25	70	°C	-
4	Storage Temperature	Tstg	-55	~	125	°C	-
5	Supply Voltage	VDD	3.3 ±10%			V	-
6	Input Current	Icc	-	-	18	mA	-
7	Enable Control	-	Yes			-	Pad 1
8	Output Load : CMOS	CL	15			pF	-
9	Output Voltage High	VoH	90%Vdd	-	-	V	-
10	Output Voltage Low	VoL	-	-	10%Vdd	V	-
11	Rise Time	Tr	-	-	7	ns	10% 90%VDD Level
12	Fall Time	Tf	-	-	7	ns	90% 10%VDD Level
13	Symmetry (Duty ratio)	TH/T	45	~	55	%	-
14	Start-up Time	Tosc	-	-	10	ms	-
15	Enable Voltage High	Vhi	70%Vdd	-	-	V	-
16	Disable Voltage Low	Vlo	-	-	30%Vdd	V	-
17	Aging	-	±3			ppm/yr.	1st. Year at 25
19	Output Disable Delay Time	T off	-	-	150	us	-
20	Output Enable Delay Time	T on	-	-	150	us	-

**■ DIMENSIONS**

(Unit:mm)

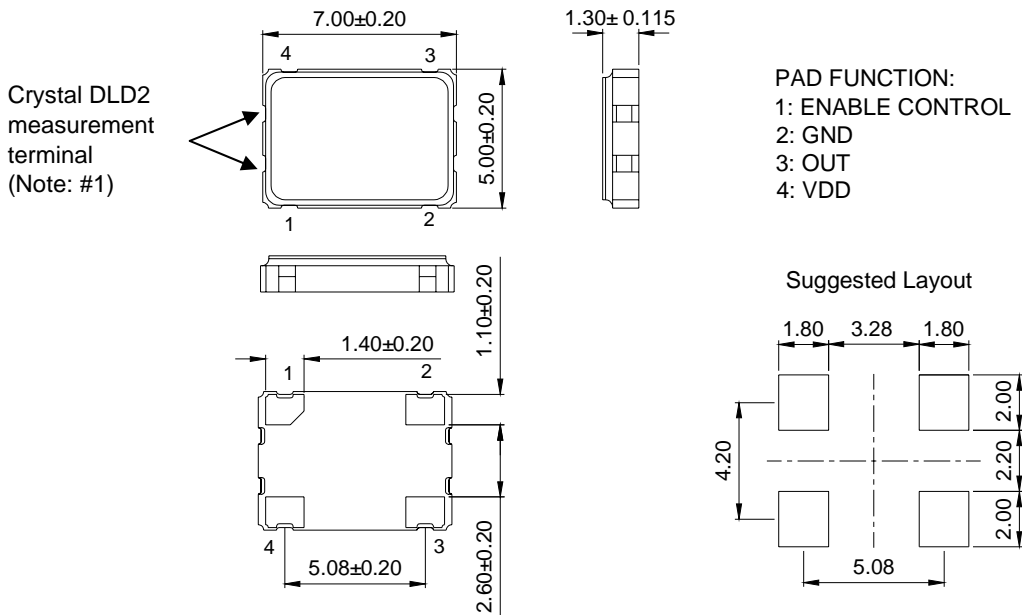

Note: #1. DLD2 / Drive Level Dependency 2 Maximum resistance minus minimum resistance.

**■ MARKING**

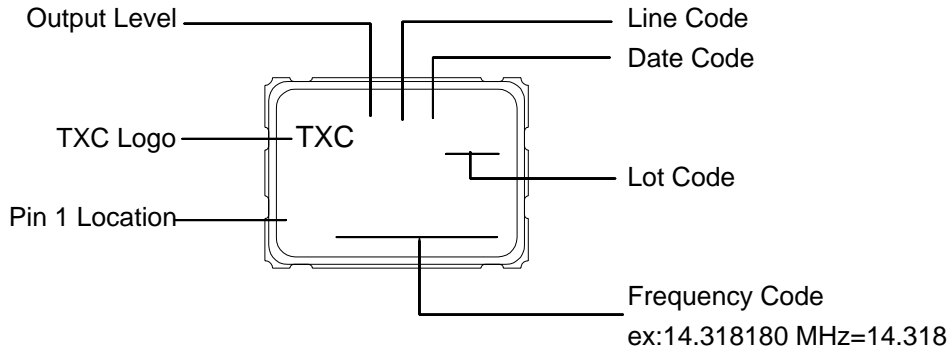

Output Level:

VDD(V)	5	3.3	2.8	2.5	1.8	2.9	3.0	2.85	2.6	2.55	2	1.5	2.7
CODE	A	B	C	D	E	F	G	H	J	K	L	M	N

Date Code:

YEAR \ MONTH				MONTH											
				JAN	FEB	MAR	APR	MAY	JUN	JUL	AUG	SEP	OCT	NOV	DEC
2005	2009	2013	2017	A	B	C	D	E	F	G	H	J	K	L	M
2006	2010	2014	2018	N	P	Q	R	S	T	U	V	W	X	Y	Z
2007	2011	2015	2019	a	b	c	d	e	f	g	h	j	k	l	m
2008	2012	2016	2020	n	p	q	r	s	t	u	v	w	x	y	z

\*This date code will be cycled every four years

**Production location: Taiwan**

**TEST DIAGRAM**

Control input (output enable/disable)

Logic 1 or open on pad 1: Oscillator output

Logic 0 on pad 1 : Disable output to high impedance

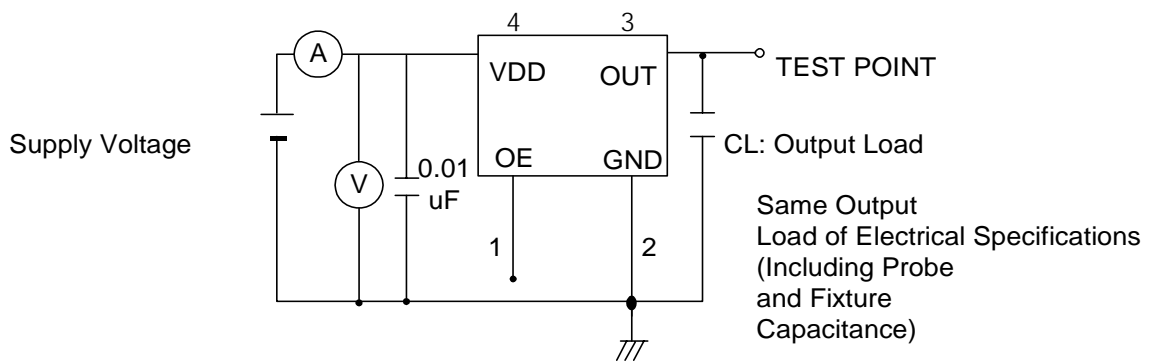

**WAVEFORM CONDITIONS**

Waveform measurement system should have a min. bandwidth of 5 times the frequency being tested.

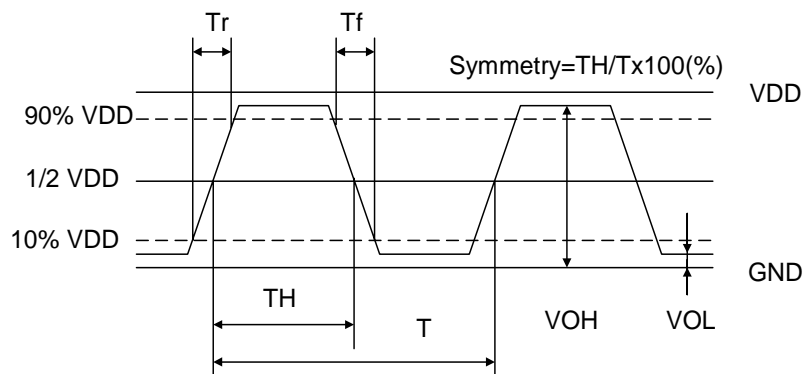

### ■ OUTPUT ENABLE / DISABLE DELAY

The following figure shows the oscillator timing during normal operation . Note that when the device is in standby, the oscillator stops. When standby is released, the oscillator starts and stable oscillator output occurs after a short delay.

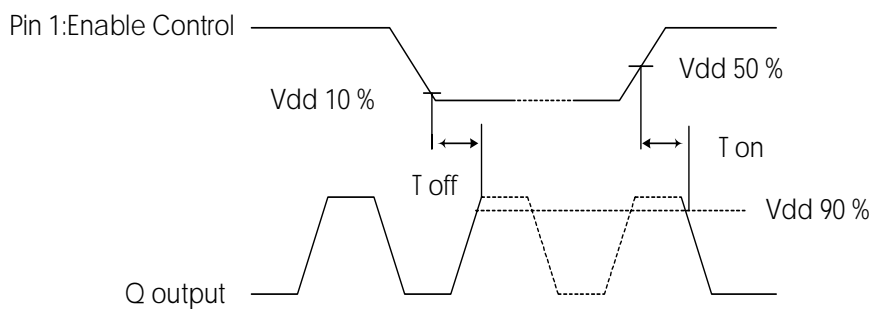

### ■ SUGGESTED REFLOW PROFILE

Total time : 200 sec. Max.

Solder melting point :220 °C

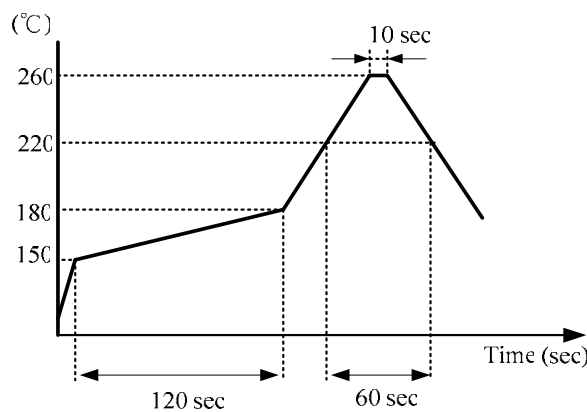

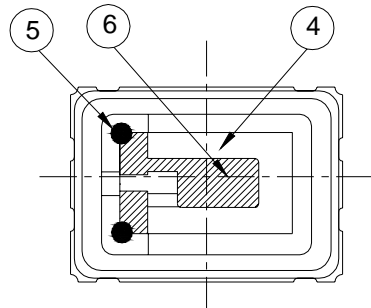
**■ STRUCTURE ILLUSTRATION**

A-A' sectional drawing

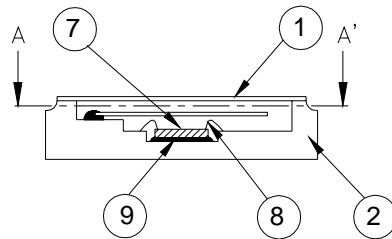

B-B' sectional drawing

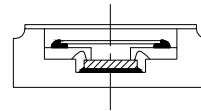

C-C' sectional drawing

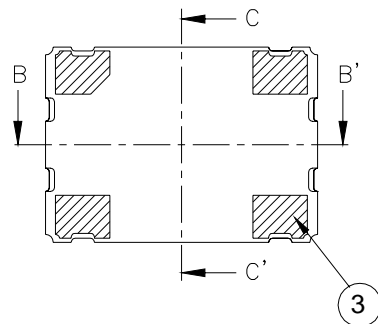

NO	COMPONENTS	MATERIALS	FINISH/SPECIFICATIONS
1	LID	Kovar (Fe/Co/Ni)	-
2	Base(Package)	Ceramic (Al <sub>2</sub> O <sub>3</sub> ) + Kovar (Fe/Co/Ni)+ Ag/Cu	Color black
3	PAD	Au	Tungsten metalize + Ni plating + Au plating
4	Crystal blank	SiO <sub>2</sub>	-
5	Conductive adhesive	Ag	Silicon resin
6	Electrode	Noble Metal	-
7	IC chip	-	-
8	Bonding wire	Au	Pad 1 options : NC is 5 wires , EN is 6 wires.
9	Die attached	Conductive (Ag)	Epoxy resin

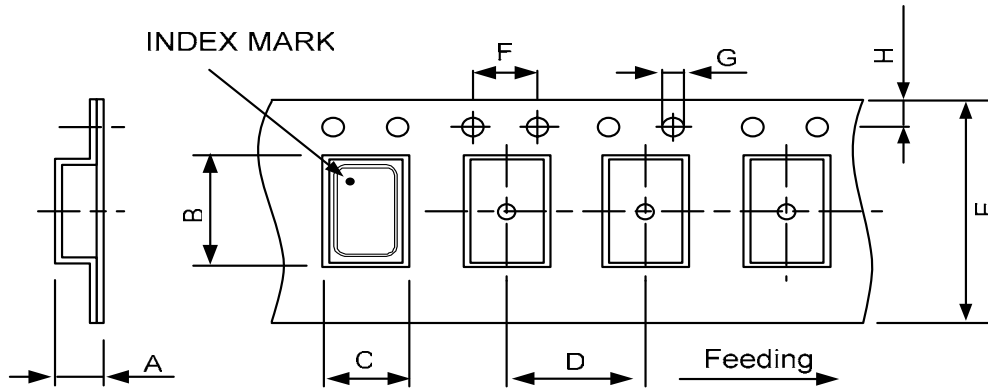

**PACKING**

DIMENSIONS	A	B	C	D	E	F	G	H	
		2.30	7.90	5.45	8.00	16.00	4.00	1.50	1.75

## REMARK :

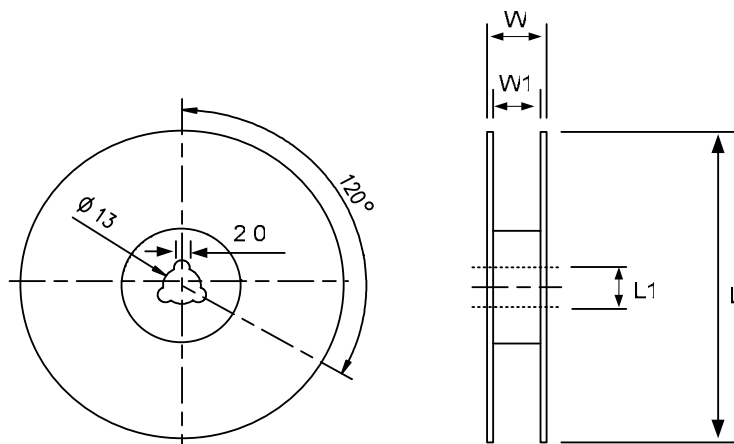
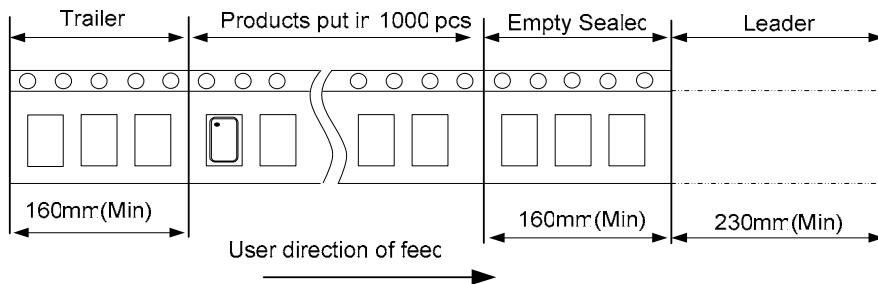

DIMENSIONS	L	L1	W	W1	pcs / Reel (UNIT : mm)
		180	13	20.5	16

## RELIABILITY SPECIFICATIONS

### 1. Mechanical Endurance

No.	Test Item	Test Methods	REF. DOC
1.1	Drop Test	75 cm height, 3 times on concrete floor .	JIS C6701
1.2	Mechanical Shock	Device are shocked to half sine wave ( 1000 G ) three mutually perpendicular axes each 3 times. 0.5m sec. duration time	MIL-STD-202F
1.3	Vibration	Frequency range                      10 ~ 2000 Hz Amplitude                                      1.52 mm/20G Sweep time                                      20 minutes Perpendicular axes each test time      4 Hrs (Total test time 12 Hrs)	MIL-STD-883E
1.4	Gross Leak	Standard Sample For Automatic Gross Leak Detector, Test Pressure: 2kg / cm <sup>2</sup>	MIL-STD-883E
1.5	Fine Leak	Helium Bombing 4.5 kgf / cm <sup>2</sup> for 2 Hrs	
1.6	Solderability	Temperature                                      245 ± 5 Immersing depth                                0.5 mm minimum Immersion time                                 5 ± 1 seconds Flux                                                      Rosin resin methyl alcohol solvent ( 1 : 4 )	MIL-STD-883E

### 2. Environmental Endurance

No.	Test Item	Test Methods	REF. DOC
2.1	Resistance To Soldering Heat	Pre-heat temperature                      125 Pre-heat time                                      60 ~ 120 sec. Test temperature                                260 ± 5 Test time                                              10 ± 1 sec.	MIL-STD-202F
2.2	High Temp. Storage	+ 125 ± 3 for 1000 ± 12 Hrs	MIL-STD-883E
2.3	Low Temp. Storage	- 40 ± 3 for 1000 ± 12 Hrs	
2.4	Thermal Shock	Total 100 cycles of the following temperature cycle 	MIL-STD-883E
2.5	Pressure Cooker Storage	121 ± 3 , RH100% , 2 bar , 240 Hrs	JIS C6701
2.6	High Temp & Humidity	85 ± 3 , RH 85% , 1000 Hrs	JIS C5023

单击下面可查看定价，库存，交付和生命周期等信息

[>>TXC\(台湾晶技\)](#)