



ISO9001 & ISO14001 & TS16949 **CHILISIN ELECTRONICS CORP.**

RoHS & Halogen Free & REACH Compliance.

SPECIFICATION FOR APPROVAL

Customer : _____

Customer P/N: _____

Drawing No : _____

Quantity : _____ Pcs. DATE : **2016/07/05**

Chilisin P/N : **HHEIL201610A-R47M-QM**

SPECIFICATION ACCEPTED BY:	
COMPONENT ENGINEER	
ELECTRICAL ENGINEER	
MECHANICAL ENGINEER	
APPROVED	
REJECTED	

<p>奇力新電子股份有限公司 Chilisin Electronics Corp No. 29, Alley 301, Tehhsin Rd., Hukou, Hsinchu 303, Taiwan TEL : +886-3- 599-2646 FAX : +886-3- 599-9176 E-mail : sales@chilisin.com.tw http : //www.chilisin.com.tw</p>	<p>東莞奇力新電子有限公司 Chilisin Electronics (Dongguan) Co., Ltd. No. 78, Puxing Rd., Yuliangwei Administration Area, Qingxi Town, Dongguan City, Guangdong, China TEL : +86-769-8773-0251~3 FAX : +86-769-8773-0232 E-mail : cect@chilisin.com.tw</p>
<p>奇力新電子(河南)有限公司 Chilisin Electronics (Henan) Co., Ltd. XiuWu Xian, industry gathering area JiaoZuo, Henan China Postal Code:454350 TEL:+86-391-717-0682 FAX:+86-391-717-0666</p>	<p>蘇州奇益新電子有限公司 SUZHOU QI YIXIN Electronics Co., Ltd. No.143, Song Shan Rd., Suzhou New District, Suzhou, China Postal Code:215129 TEL:+86-512-6841-2350 FAX:+86-512-6841-2356 E-mail : suzhou@chilisin.com.tw</p>

Drawn by 張鈺雯 chang.yuwen	Checked by 張鈺雯 chang.yuwen	Approved by 鍾瑞民 jacky.chung
------------------------------------	--------------------------------------	---------------------------------------

HHEIL201610A Series Specification

1 Scope: This specification applies to Molding power inductors

2 Part Numbering:

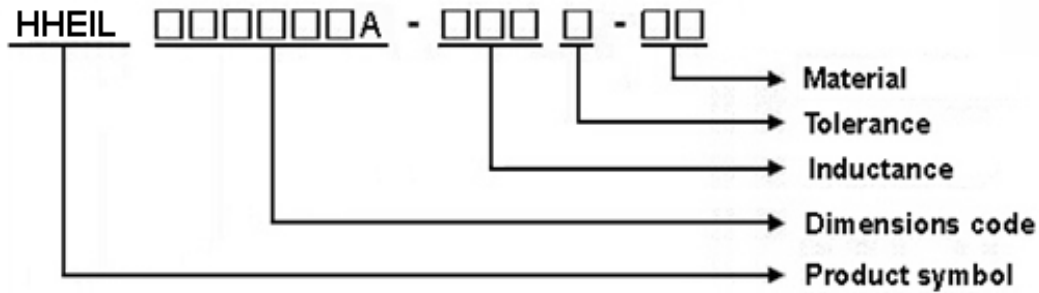

3 Rating:

Operating Temperature: $-40^{\circ}\text{C} \sim 125^{\circ}\text{C}$ (Including self - temperature rise)

Storage Temperature: $-40^{\circ}\text{C} \sim 125^{\circ}\text{C}$ (after PCB)

$-5^{\circ}\text{C} \sim 35^{\circ}\text{C}$, Humidity 45%~85% (before PCB)

4 Marking:

No Marking

5 Standard Testing Condition

	Unless otherwise specified	In case of doubt
Temperature	Ordinary Temperature(15 to 35°C)	20 to 30°C
Humidity	Ordinary Humidity(25 to 85% RH)	50 to 80 %RH

HHEIL201610A Series Specification

6 Configuration and Dimensions:

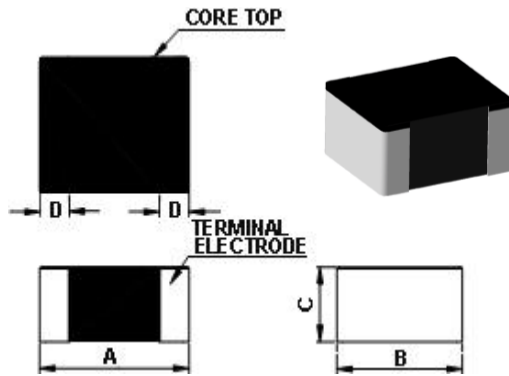

Dimensions in mm

TYPE	HHEIL201610A
A	2.0±0.2
B	1.6±0.2
C	1.0max
D	0.5±0.3

7 ELECTRICAL CHARACTERISTICS :

Part No.	Inductance (uH)	Tolerance (±%)	Test Freq.	I _{rms} (A) Max.(Typ)	I _{sat} (A) Max.(Typ)	RDC(mΩ) Max.(Typ)
HHEIL201610A-R47M-QM	0.47	20	2MHz,0.2V	4.1(4.5)	5.3(5.6)	31(25)

NOTE:

1. Operating temperature range - 40°C ~ 125°C (Including self - temperature rise)
2. I_{dc}: DC current (A) that will cause an approximate ΔT of 40°C.
3. I_{sat}: DC current (A) that will cause L_o to drop approximately 30%
4. All test data is referenced to 25°C ambient
5. Absolute maximum voltage 25VDC

HHEIL201610A Series Specification

8 HHEIL201610A Series

8.1 Construction:

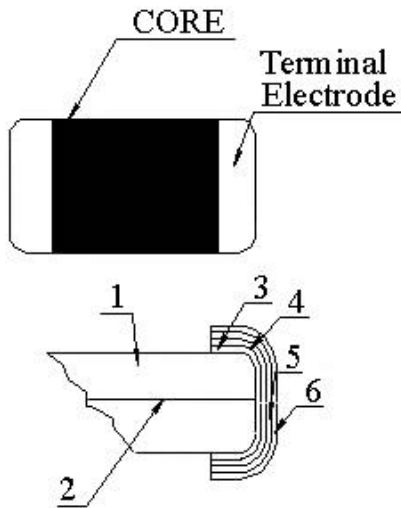

8.2 Material List:

No	Part	Material
1	Core	Metal Powder
2	Wire	Copper wire
3	Sputter/Plating	Cu
4	Silver Electrode	Ag
5	Plating	Ni
6	Plating	Sn

HHEIL201610A Series Specification

9 Reliability Of Molding power inductors

1-1.Mechanical Performance

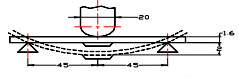
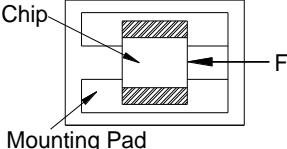
No	Item	Specification	Test Method
1-1-1	Flexure Strength	The forces applied on the right conditions must not damage the terminal electrode and the metal body	Test device shall be soldered on the substrate Substrate Dimension: 100x40x1.6mm Deflection: 2.0mm Keeping Time: 30sec 
1-1-2	Vibration	Appearance:No damage (for microscope of CASTOR MZ-45 20X) Inductance change shall be within $\pm 20\%$	Test device shall be soldered on the substrate Oscillation Frequency: 10 to 55 to 10Hz for 1min Amplitude: 1.5mm Time: 2hrs for each axis (X, Y & Z), total 6hrs
1-1-3	Resistance to Soldering Heat	Appearance: No damage More than 75% of the terminal electrode should be covered with solder. Inductance: within $\pm 20\%$ of initial value	Pre-heating: 150°C, 1min Solder Composition: Sn/Ag3.0/Cu0.5(Pb-Free) Solder Temperature: 260 \pm 5°C Immersion Time: 10 \pm 1sec
1-1-4	Solder ability	The electrodes shall be at least 95% covered with new solder coating	Pre-heating: 150°C, 1min Solder Composition: Sn/Ag3.0/Cu0.5(Pb-Free) Solder Temperature: 245 \pm 5°C Immersion Time: 4 \pm 1sec
1-1-5	Terminal Strength Test	No split termination  Chip Mounting Pad	Test device shall be soldered on the substrate, then apply a force in the direction of the arrow. Force : 5N Keeping Time: 10 \pm 1sec

1-2.Environmental Performance

No	Item	Specification	Test Method															
1-2-1	Temperature Cycle	Appearance: No damage Inductance: within $\pm 20\%$ of initial value	One cycle:															
			<table border="1"> <thead> <tr> <th>Step</th> <th>Temperature (°C)</th> <th>Time (min)</th> </tr> </thead> <tbody> <tr> <td>1</td> <td>-40\pm3</td> <td>30</td> </tr> <tr> <td>2</td> <td>25\pm2</td> <td>3</td> </tr> <tr> <td>3</td> <td>125\pm3</td> <td>30</td> </tr> <tr> <td>4</td> <td>25\pm2</td> <td>3</td> </tr> </tbody> </table>	Step	Temperature (°C)	Time (min)	1	-40 \pm 3	30	2	25 \pm 2	3	3	125 \pm 3	30	4	25 \pm 2	3
			Step	Temperature (°C)	Time (min)													
			1	-40 \pm 3	30													
2	25 \pm 2	3																
3	125 \pm 3	30																
4	25 \pm 2	3																
Total: 100cycles																		
Measured after exposure in the room condition for 24hrs																		
1-2-2	Humidity Resistance		Temperature: 60 \pm 2°C Relative Humidity: 90 ~ 95% / Time: 500hrs Measured after exposure in the room condition for 24hrs															
1-2-3	High Temperature Resistance		Temperature: 85 \pm 3°C Relative Humidity: 0% / Time: 500hrs Measured after exposure in the room condition for 24hrs															
1-2-4	Low Temperature Resistance		Temperature: -40 \pm 3°C Relative Humidity: 0% / Time: 500hrs Measured after exposure in the room condition for 24hrs															

HHEIL201610A Series Specification

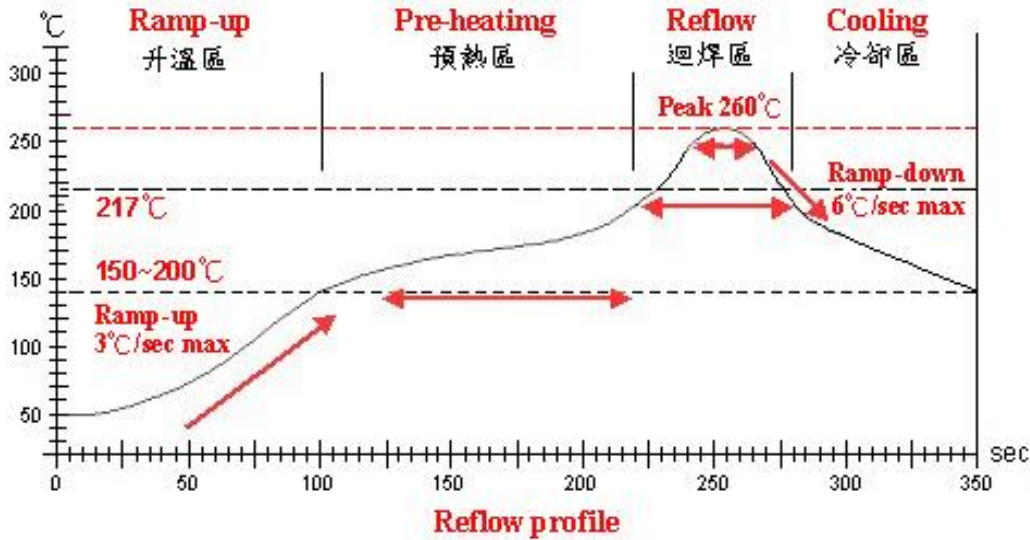

Lead-Free(LF) 標準溫度分析範圍

Refer to J-STD-020C

管制項目 Item.	升温區 Ramp-up	預熱區 Pre-heating	迴焊區 Reflow	Peak Temp	冷卻區 Cooling
溫度範圍 Temp.scope	R.T. ~ 150°C	150°C ~ 200°C	217°C	260±5°C	Peak Temp. ~ 150°C
標準時間 Time spec.	—	60 ~ 180 sec	60 ~ 150sec	20 ~ 40 sec	—
實際時間 Time result	—	75 ~ 100 sec	90 ~ 120sec	20 ~ 35 sec	—

NOTE :

1. Re-flow possible times : within 2 times
2. Nitrogen adopted is recommended while in re-flow

HHEIL201610A Series Specification

10 Packaging

10.1 Packaging -Cover tape

The force for tearing off cover tape is 10 to 100 grams in the arrow direction.

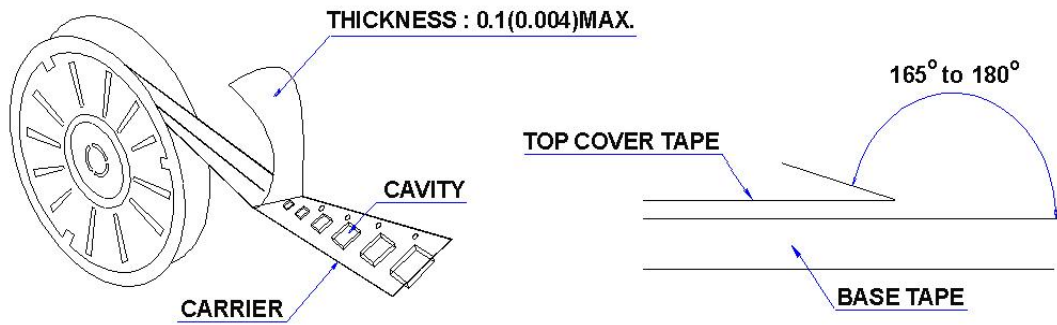

10.2 Packaging Quantity

TYPE	PCS/REEL
HHEIL201610A	3000

10.3 Reel Dimensions

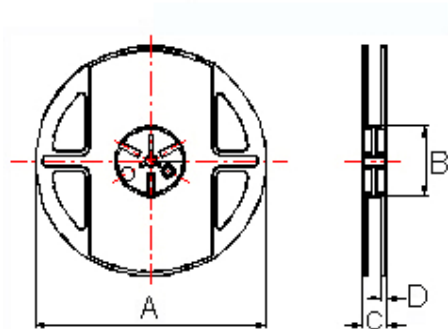

Dimensions in mm

TYPE	A	B	C	D
HHEIL201610A	178	60	12	1.5

HHEIL201610A Series Specification

10 Packaging

10.4 Tape Dimensions in mm

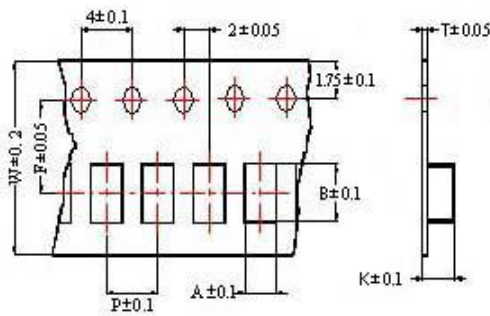

Tape Material

Carrier tape : Polystyrene

Cover tape : Polyethylene

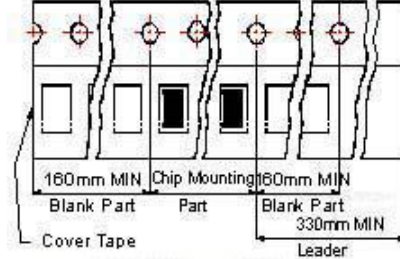

TYPE	A	B	T	W	P	F	K
HHEIL201610A	1.80	2.20	0.22	8	4	3.5	1.15

11 Recommended Pattern

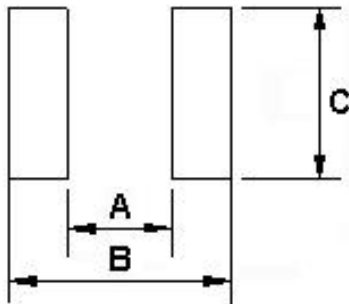

Dimensions in mm

TYPE	A	B	C
HHEIL201610A	0.7	2.3	1.8

12 Note:

- Please make sure that your product has been evaluated and confirmed against your specifications when our product is mounted to your product.
- Do not knock nor drop.
- All the items and parameters in this product specification have been prescribed on the premise that our product is used for the purpose, under the condition and in the environment agreed upon between you and us. You are requested not to use our product deviating from such agreement.
- Please keep the distance between transformer/coil and other components (refer to the standard IEC 950)
- After manufacturing process, there might be slight irregular shape on the edge of the products, and it's a normal phenomenon that can be neglected
- The moisture sensitivity level (MSL) of products is classified as level 1.

HHEIL201610A Series Specification

13 Graph:

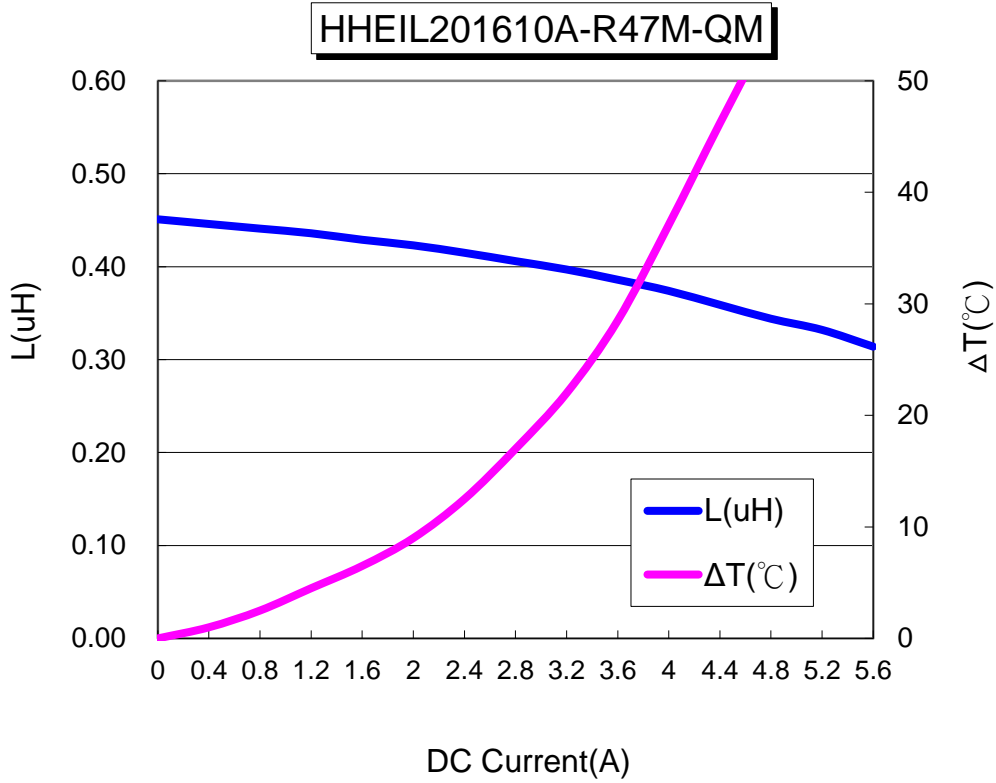

单击下面可查看定价，库存，交付和生命周期等信息

[>>CHILISIN\(奇力新\)](#)