

Doc. version: 0.3
Total pages: 16
Date: 2011/11/18

LED Product Spec

PC56H01 V4



0.4W~0.6W

MODEL NAME: PC56H01 V4

< ◆ > Preliminary Specification
< > Final Specification

Note: The content of this specification is subject to change without prior notice.

© 2011 Lextar Electronics
All Rights Reserved,
Do Not Copy.

Record of Revision

Version and Date	Page	Old description	New Description	Remark
0.1	14			
0.2	16	Old Lextar Color Binning	New Lextar Color Binning	
0.3	8	Pad design	Pad design (W zener)	

1 Specification

1.1 Absolute Maximum Ratings (Ta=25°C)

Item	Symbol	Absolute Maximum Rating	Unit
Forward Current	I _F	180	mA
Pulse Forward Current *1	I _{FP}	350	mA
Reverse Voltage	V _R	5	V
Power Dissipation	P _D	0.6	W
Operating Temperature	T _{opr}	-30 ~ + 85	°C
Storage Temperature	T _{stg}	-40 ~ +100	°C
Soldering Temperature	T _{slid}	Reflow Soldering : 260 (10sec) Hand Soldering : 350 (3sec)	°C

*1: I_{FP} Condition: Duty 1/10, Pulse within 10msec.

1.2 Initial Electrical/Optical Characteristics (Ta=25°C)

Item	Symbol	Condition	Min.	Typ.	Max.	Unit
Forward Voltage	V _F	I _F =120 mA	2.9		3.5	V
Luminous Flux	Φ _v	2700K _(120mA)		39		lm
		3000K _(120mA)		40		
		4000K _(120mA)		42		
		5000K _(120mA)		44		
		5700K _(120mA)		45		
View Angle	2θ _{1/2}	I _F =120 mA	-	120	-	degree
Color Rendering Index		I _F =120 mA	80			
Chromaticity Coordinate *1	x	I _F =120 mA	Refer to ranking table			-
	y	I _F =120 mA				
Thermal Resistance	R _{th(j-s)}		<35			K/W
Heat Sink Potential			Electrically Isolated			

*1 Please refer to CIE 1931 chromaticity diagram

1.3 Ranking

1.3.1 Luminous Flux Ranks (Ta=25°C, Ranking @ 150mA is only for reference)

Item	Symbol	Condition	Min.	Max.	Condition	Min.	Max.	Unit
YI	Φ _v	I _F =120 mA	33	34.5	I _F =150 mA	39.6	41.4	lm
YJ	Φ _v	I _F =120 mA	34.5	36	I _F =150 mA	41.4	43.2	
YK	Φ _v	I _F =120 mA	36	37.5	I _F =150 mA	43.2	45	
YL	Φ _v	I _F =120 mA	37.5	39	I _F =150 mA	45	46.8	

Item	Symbol	Condition	Min.	Max.	Condition	Min.	Max.	Unit
YM	Φ_v	$I_F=120\text{ mA}$	39	40.5	$I_F=150\text{ mA}$	46.8	48.6	lm
YN	Φ_v	$I_F=120\text{ mA}$	40.5	42	$I_F=150\text{ mA}$	48.6	50.4	
YO	Φ_v	$I_F=120\text{ mA}$	42	43.5	$I_F=150\text{ mA}$	50.4	52.2	
YP	Φ_v	$I_F=120\text{ mA}$	43.5	45	$I_F=150\text{ mA}$	52.2	54	
YQ	Φ_v	$I_F=120\text{ mA}$	45	46.5	$I_F=150\text{ mA}$	54	55.8	

*Luminous Flux Measurement allowance is $\pm 7\%$

1.3.2 Forward Voltage Ranks (Ta=25°C, Ranking @ 150mA is only for reference)

Item	Symbol	Condition	Min.	Max.	Condition	Min.	Max.	Unit
1	V_F	$I_F=120\text{ mA}$	2.9	3.0	$I_F=150\text{ mA}$	2.98	3.08	V
2	V_F	$I_F=120\text{ mA}$	3.0	3.1	$I_F=150\text{ mA}$	3.08	3.18	
3	V_F	$I_F=120\text{ mA}$	3.1	3.2	$I_F=150\text{ mA}$	3.18	3.28	
4	V_F	$I_F=120\text{ mA}$	3.2	3.3	$I_F=150\text{ mA}$	3.28	3.38	
5	V_F	$I_F=120\text{ mA}$	3.3	3.4	$I_F=150\text{ mA}$	3.38	3.48	
6	V_F	$I_F=120\text{ mA}$	3.4	3.5	$I_F=150\text{ mA}$	3.48	3.58	

* Forward Voltage Measurement allowance is $\pm 3\%$

1.3.3 Color Rank (If=120mA, Ta=25°C)

Chromaticity Diagram

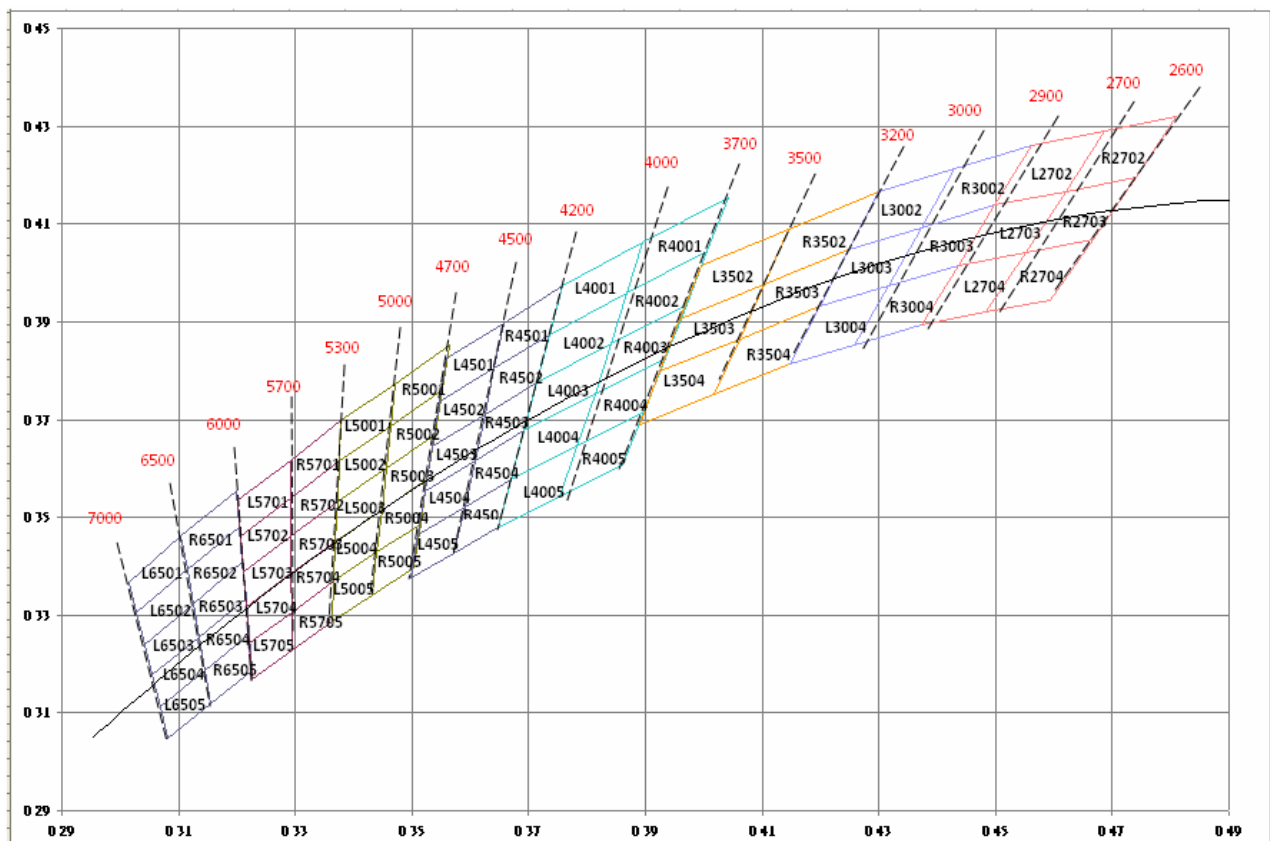

2700K				3000K	
<i>R2702</i>	<i>0.4687</i>	<i>0.4289</i>	<i>R3002</i>	<i>0.4430</i>	<i>0.4212</i>
	<i>0.4620</i>	<i>0.4166</i>		<i>0.4374</i>	<i>0.4093</i>
	<i>0.4740</i>	<i>0.4194</i>		<i>0.4499</i>	<i>0.4138</i>
	<i>0.4810</i>	<i>0.4319</i>		<i>0.4562</i>	<i>0.4260</i>
<i>R2703</i>	<i>0.4620</i>	<i>0.4166</i>	<i>R3003</i>	<i>0.4374</i>	<i>0.4093</i>
	<i>0.4551</i>	<i>0.4042</i>		<i>0.4317</i>	<i>0.3973</i>
	<i>0.4666</i>	<i>0.4069</i>		<i>0.4436</i>	<i>0.4015</i>
	<i>0.4740</i>	<i>0.4194</i>		<i>0.4499</i>	<i>0.4138</i>
<i>R2704</i>	<i>0.4551</i>	<i>0.4042</i>	<i>R3004</i>	<i>0.4317</i>	<i>0.3973</i>
	<i>0.4483</i>	<i>0.3919</i>		<i>0.4259</i>	<i>0.3853</i>
	<i>0.4593</i>	<i>0.3944</i>		<i>0.4373</i>	<i>0.3893</i>
	<i>0.4666</i>	<i>0.4069</i>		<i>0.4436</i>	<i>0.4015</i>
<i>L2702</i>	<i>0.4562</i>	<i>0.4260</i>	<i>L3002</i>	<i>0.4299</i>	<i>0.4165</i>
	<i>0.4499</i>	<i>0.4138</i>		<i>0.4248</i>	<i>0.4048</i>
	<i>0.4620</i>	<i>0.4166</i>		<i>0.4374</i>	<i>0.4093</i>
	<i>0.4687</i>	<i>0.4289</i>		<i>0.4430</i>	<i>0.4212</i>
<i>L2703</i>	<i>0.4499</i>	<i>0.4138</i>	<i>L3003</i>	<i>0.4248</i>	<i>0.4048</i>
	<i>0.4436</i>	<i>0.4015</i>		<i>0.4198</i>	<i>0.3931</i>
	<i>0.4551</i>	<i>0.4042</i>		<i>0.4317</i>	<i>0.3973</i>
	<i>0.4620</i>	<i>0.4166</i>		<i>0.4374</i>	<i>0.4093</i>
<i>L2704</i>	<i>0.4436</i>	<i>0.4015</i>	<i>L3004</i>	<i>0.4198</i>	<i>0.3931</i>
	<i>0.4373</i>	<i>0.3893</i>		<i>0.4147</i>	<i>0.3814</i>
	<i>0.4483</i>	<i>0.3919</i>		<i>0.4259</i>	<i>0.3853</i>
	<i>0.4551</i>	<i>0.4042</i>		<i>0.4317</i>	<i>0.3973</i>

4000K			5000K		
<i>R4001</i>	<i>0.3896</i>	<i>0.4061</i>	<i>R5001</i>	<i>0.3470</i>	<i>0.3773</i>
	<i>0.3869</i>	<i>0.3958</i>		<i>0.3463</i>	<i>0.3687</i>
	<i>0.4006</i>	<i>0.4044</i>		<i>0.3552</i>	<i>0.3760</i>
	<i>0.4042</i>	<i>0.4153</i>		<i>0.3565</i>	<i>0.3851</i>
<i>R4002</i>	<i>0.3869</i>	<i>0.3958</i>	<i>R5002</i>	<i>0.3463</i>	<i>0.3687</i>
	<i>0.3842</i>	<i>0.3855</i>		<i>0.3456</i>	<i>0.3601</i>
	<i>0.3970</i>	<i>0.3935</i>		<i>0.3539</i>	<i>0.3669</i>
	<i>0.4006</i>	<i>0.4044</i>		<i>0.3552</i>	<i>0.3760</i>
<i>R4003</i>	<i>0.3842</i>	<i>0.3855</i>	<i>R5003</i>	<i>0.3456</i>	<i>0.3601</i>
	<i>0.3813</i>	<i>0.3751</i>		<i>0.3448</i>	<i>0.3514</i>
	<i>0.3934</i>	<i>0.3825</i>		<i>0.3526</i>	<i>0.3578</i>
	<i>0.3970</i>	<i>0.3935</i>		<i>0.3539</i>	<i>0.3669</i>
<i>R4004</i>	<i>0.3813</i>	<i>0.3751</i>	<i>R5004</i>	<i>0.3448</i>	<i>0.3514</i>
	<i>0.3783</i>	<i>0.3646</i>		<i>0.3440</i>	<i>0.3428</i>
	<i>0.3898</i>	<i>0.3716</i>		<i>0.3514</i>	<i>0.3487</i>
	<i>0.3934</i>	<i>0.3825</i>		<i>0.3526</i>	<i>0.3578</i>
<i>R4005</i>	<i>0.3783</i>	<i>0.3646</i>	<i>R5005</i>	<i>0.3440</i>	<i>0.3428</i>
	<i>0.3753</i>	<i>0.3541</i>		<i>0.3432</i>	<i>0.3342</i>
	<i>0.3862</i>	<i>0.3607</i>		<i>0.3502</i>	<i>0.3396</i>
	<i>0.3898</i>	<i>0.3716</i>		<i>0.3514</i>	<i>0.3487</i>
<i>L4001</i>	<i>0.3758</i>	<i>0.3973</i>	<i>L5001</i>	<i>0.3379</i>	<i>0.3698</i>
	<i>0.3736</i>	<i>0.3874</i>		<i>0.3376</i>	<i>0.3616</i>
	<i>0.3869</i>	<i>0.3958</i>		<i>0.3463</i>	<i>0.3687</i>
	<i>0.3896</i>	<i>0.4061</i>		<i>0.3470</i>	<i>0.3773</i>
<i>L4002</i>	<i>0.3736</i>	<i>0.3874</i>	<i>L5002</i>	<i>0.3376</i>	<i>0.3616</i>
	<i>0.3714</i>	<i>0.3775</i>		<i>0.3373</i>	<i>0.3534</i>
	<i>0.3842</i>	<i>0.3855</i>		<i>0.3456</i>	<i>0.3601</i>
	<i>0.3869</i>	<i>0.3958</i>		<i>0.3463</i>	<i>0.3687</i>

L4003	0.3714	0.3775	L5003	0.3373	0.3534
	0.3692	0.3677		0.3369	0.3451
	0.3813	0.3751		0.3448	0.3514
	0.3842	0.3855		0.3456	0.3601
L4004	0.3692	0.3677	L5004	0.3369	0.3451
	0.3670	0.3578		0.3366	0.3369
	0.3783	0.3646		0.3440	0.3428
	0.3813	0.3751		0.3448	0.3514
L4005	0.3670	0.3578	L5005	0.3366	0.3369
	0.3648	0.3479		0.3363	0.3287
	0.3753	0.3541		0.3432	0.3342
	0.3783	0.3646		0.3440	0.3428

5700K					
R5701	0.3291	0.3617	L5701	0.3202	0.3535
	0.3292	0.3539		0.3207	0.3462
	0.3376	0.3616		0.3292	0.3539
	0.3379	0.3698		0.3291	0.3617
R5702	0.3292	0.3539	L5702	0.3207	0.3462
	0.3293	0.3461		0.3212	0.3389
	0.3373	0.3534		0.3293	0.3461
	0.3376	0.3616		0.3292	0.3539
R5703	0.3293	0.3461	L5703	0.3212	0.3389
	0.3293	0.3384		0.3217	0.3316
	0.3369	0.3451		0.3293	0.3384
	0.3373	0.3534		0.3293	0.3461
R5704	0.3293	0.3384	L5704	0.3217	0.3316
	0.3294	0.3306		0.3222	0.3243
	0.3366	0.3369		0.3294	0.3306
	0.3369	0.3451		0.3293	0.3384

R5705	0.3294	0.3306	L5705	0.3222	0.3243
	0.3295	0.3228		0.3227	0.317
	0.3363	0.3287		0.3295	0.3228
	0.3366	0.3369		0.3294	0.3306

Bin code definition

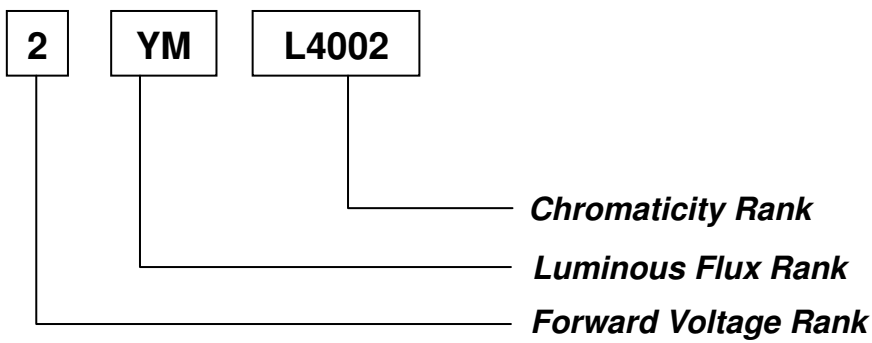

2 Outline Dimension and Recommended Soldering Pad

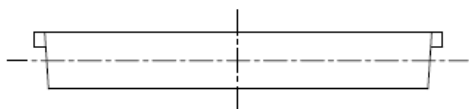

Unit : mm
Tolerance : ± 0.1

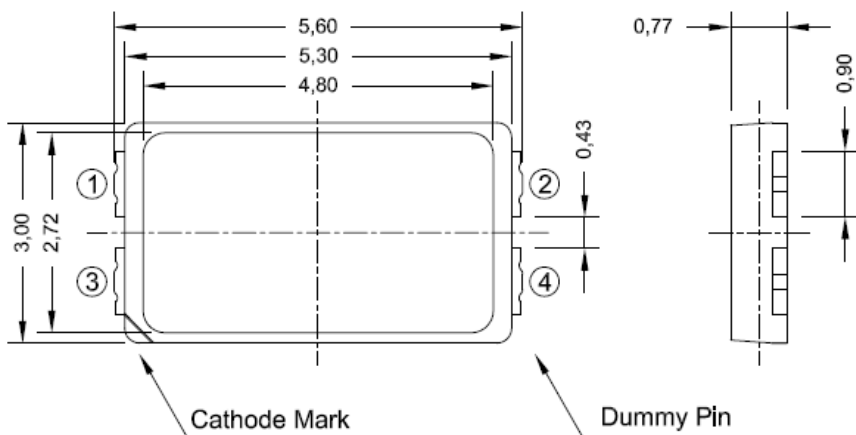

Pin Description

- Pin 1: Dummy A
- Pin 2: Thermal Pad & Anode
- Pin 3: Cathode
- Pin 4: Dummy B

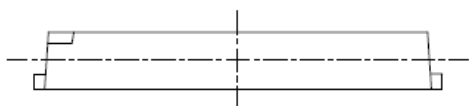

Recommended Soldering Pad Design

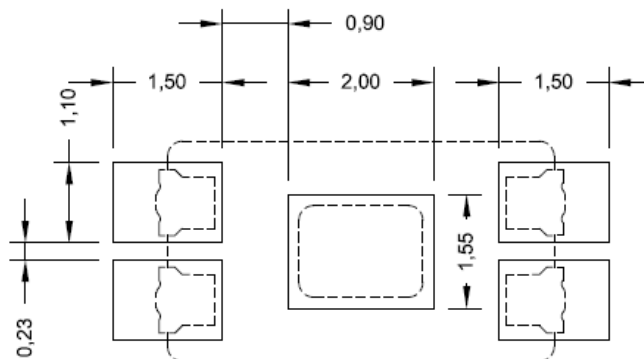
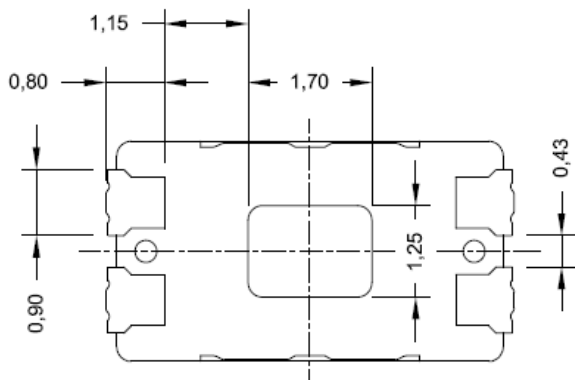

3 Reliability

3.1 Test Items

No	Item	Condition	Time/Cycle
1.	<i>Thermal shock</i>	-40°C/20minr ~20sec ~ 100°C/20min	200 cycles
2	<i>High temperature storage</i>	100°C	1000 Hrs
3	<i>Steady State Operating Life of High Temperature1</i>	85 °C/120mA	1000 Hrs
4	<i>Steady State Operating Life of Low Temperature</i>	-40 °C/120mA	1000 Hrs
5	<i>Steady State Operating Life of High Humidity Heat 1</i>	60°C/90%RH/ 120mA	1000 Hrs
6	<i>RTSH (JEDEC MSL 3)</i>	Pre-store @60°C/60%RH for 52hrs Tsltd max.=260 °C 10 sec.	3 Times

Judgment Criteria

Item	Symbol	Test Conditions	Judgment Criteria
<i>Forward Voltage</i>	Vf	I _F = 120 mA	Δ % < 10 %
<i>Luminous Intensity</i>	Iv	I _F = 120 mA	Δ % < 30 %

4 Initial Optical/Electrical Characteristics

4.1 Spectrum ($I_F = 120\text{mA}$, $T_a = 25^\circ\text{C}$)

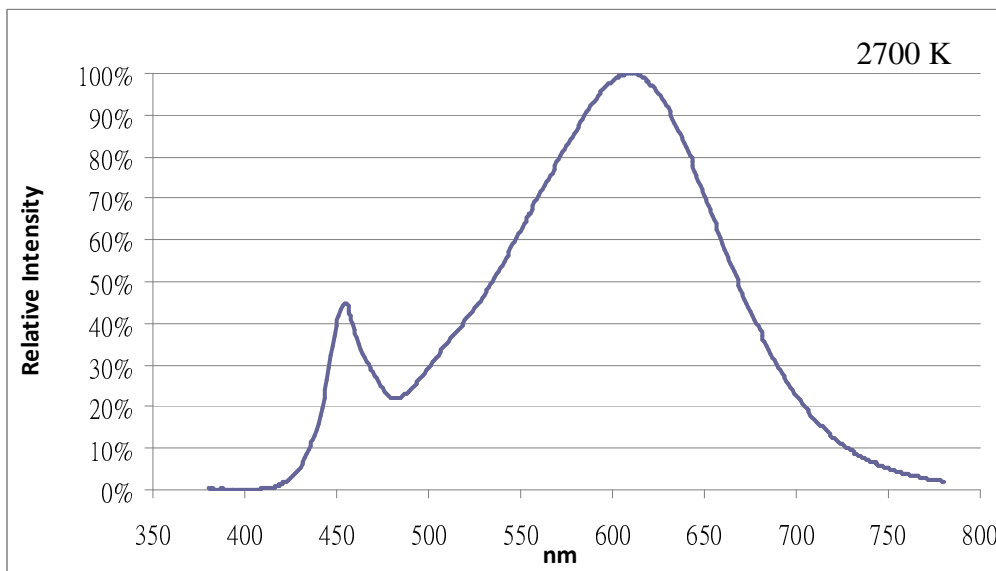

4.2 Directivity

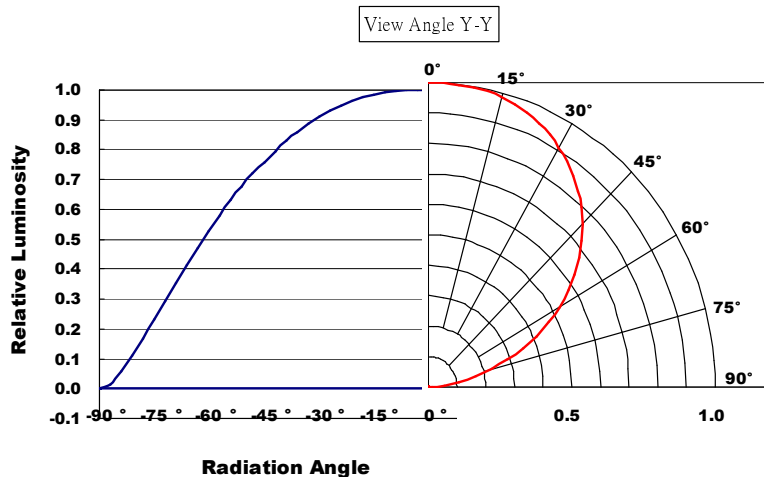
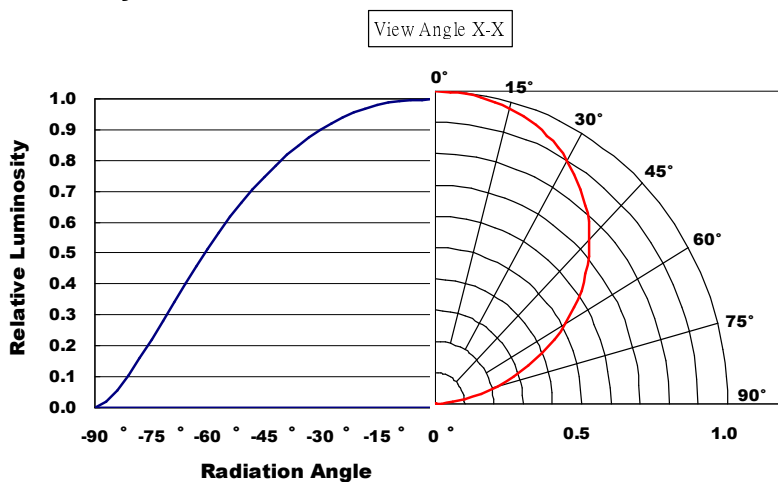

4.3 Forward Voltage vs. Forward Current

$T_a = 25^\circ\text{C}$

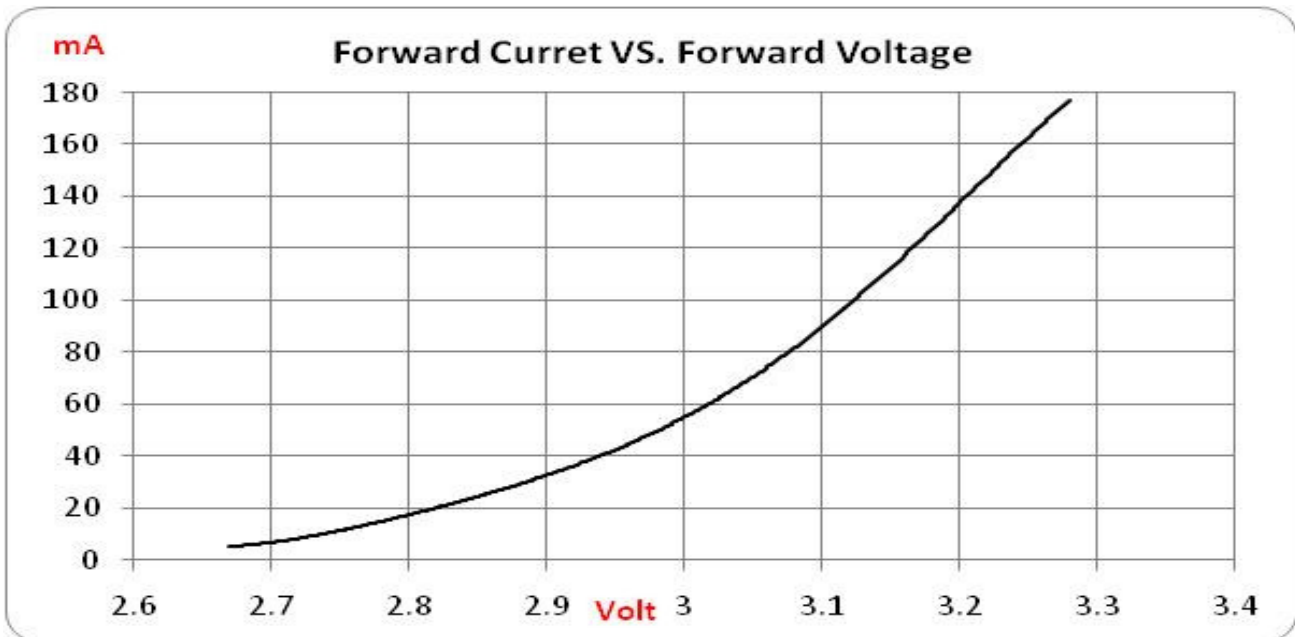

4.4 Forward Current vs. Relative Luminosity

$T_a = 25^\circ\text{C}$

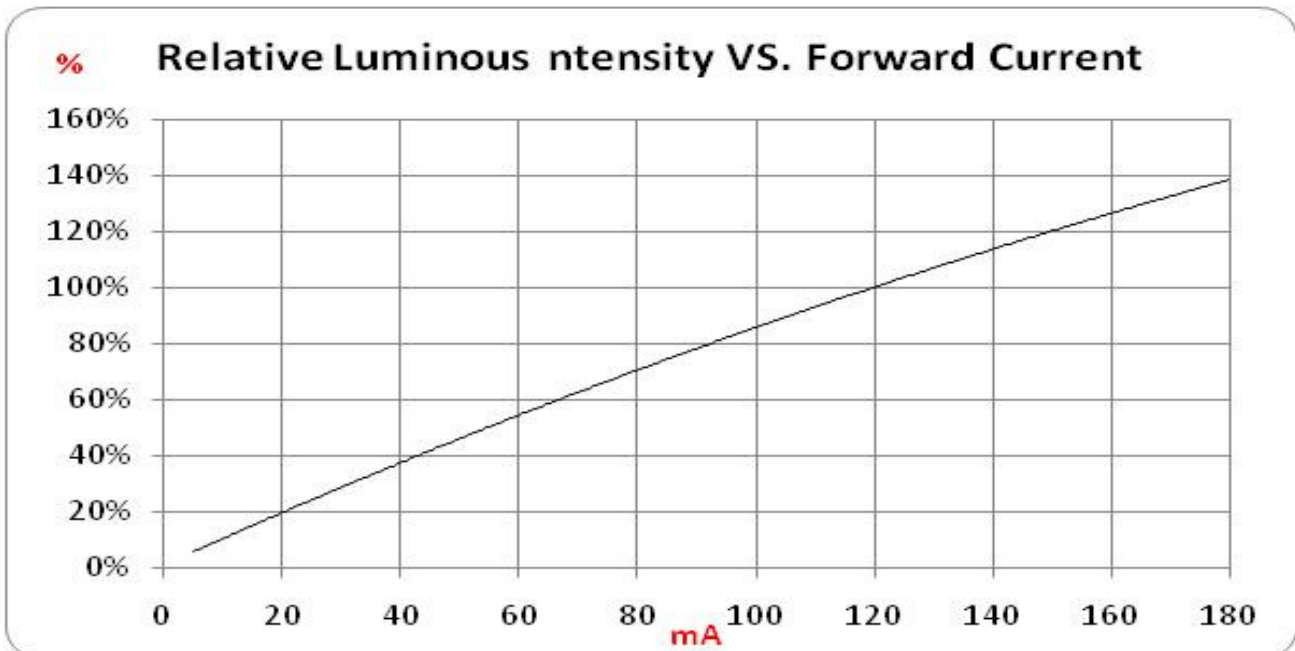

4.5 Forward Current vs. Chromaticity Coordinate

$T_a = 25^\circ\text{C}$

TBD

4.6 Forward Voltage change vs. Junction Temperature

$I_F = 120\text{mA}$

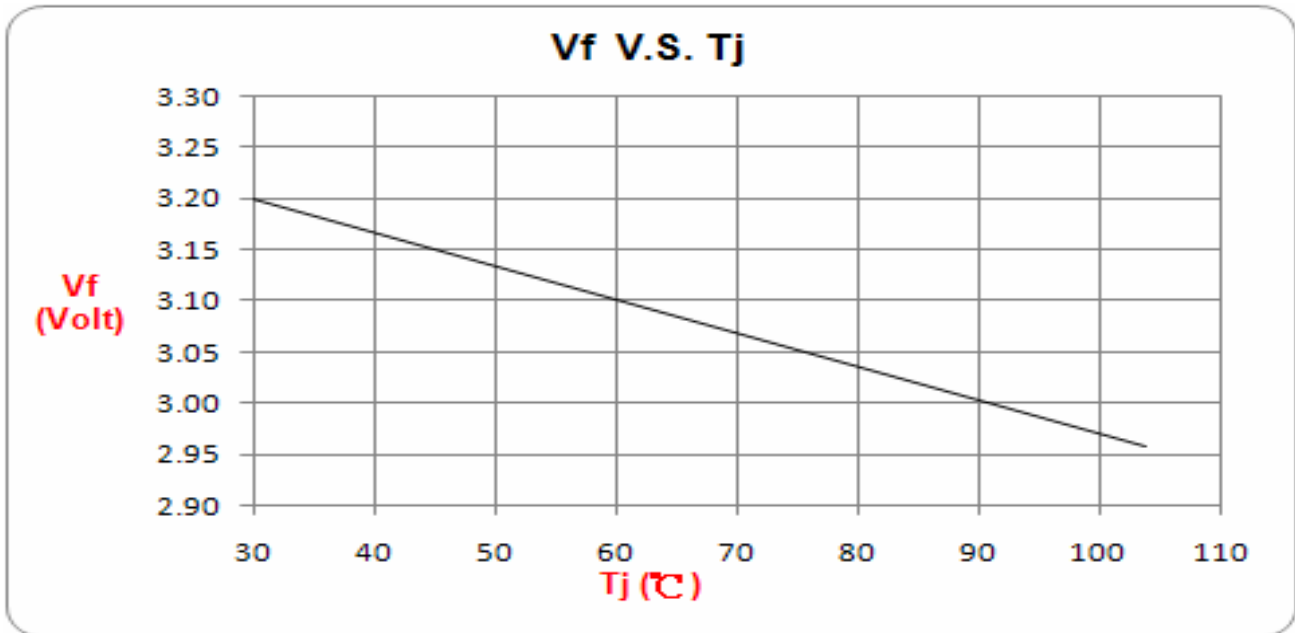

4.7 Relative Luminous Intensity vs. Junction Temperature

$I_F = 120\text{mA}$

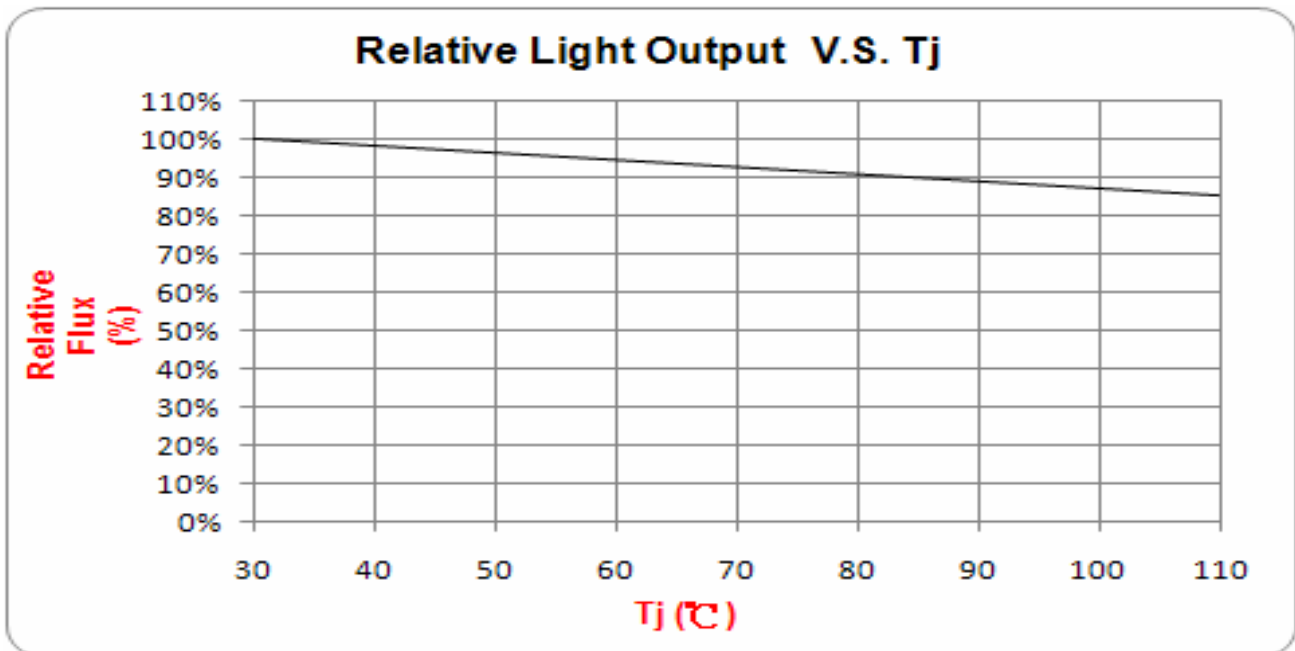

4.8 Allowable Forward Current vs. Ambient Temperature

(TBD)

4.9 Chromaticity vs. Ambient Temperature

(TBD)

5 Packaging

5.1 Carrier Tape Dimension

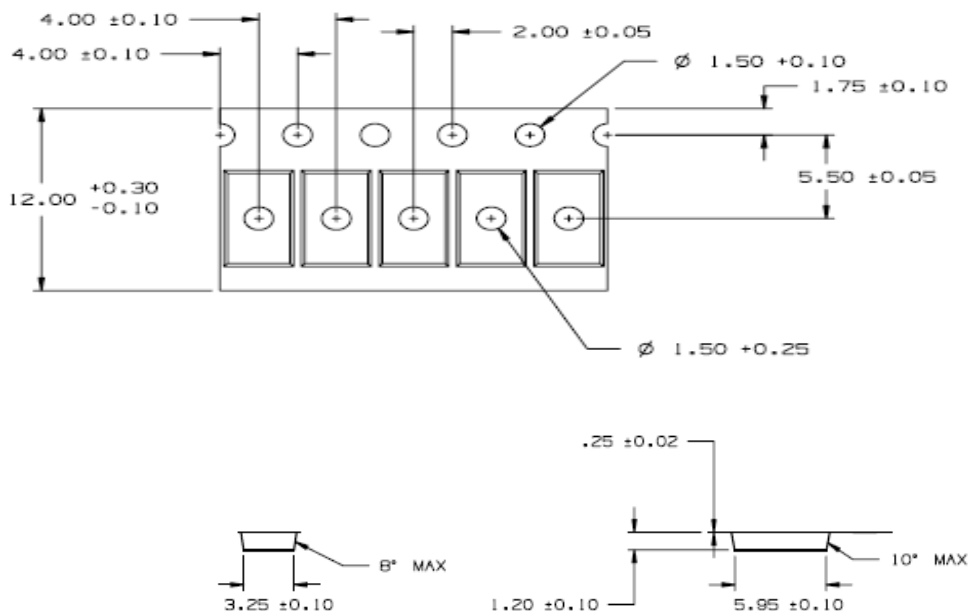

5.2 Reel Label

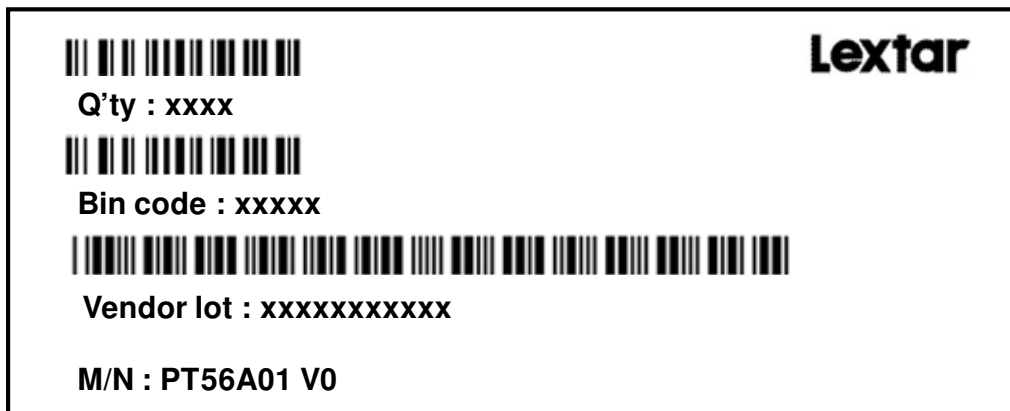

5.3 Package

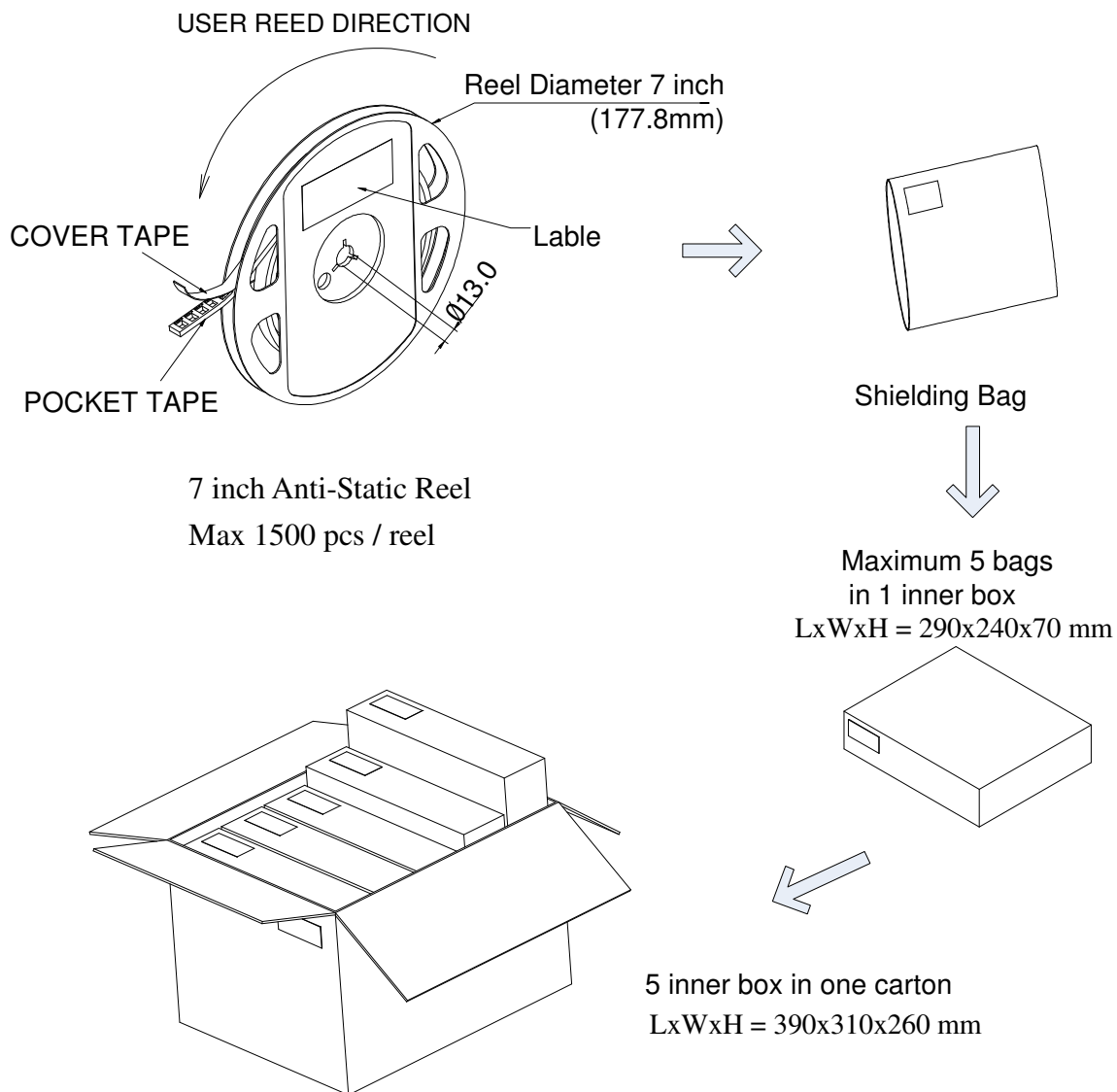

6 Precautions

6.1 Safety Precautions

- The LED light output is too strong for human eyes without shield. Prevent eye contact directly more than seconds.
- Ensure operating under maximum rating.

6.2 Storage

- Before opening the package, the LEDs should storage under 30°C, 70% RH. Recommend to use within one year.
- After opening the package bag, the LEDs should be keep under 30°C, 70% RH. Recommend to use within 2days. If unused LEDs remain, suggest to store into moisture proof bag or original package bag with moisture absorbent material such as silica gel. Reseal well is necessary.
- If the product exceeded the storage period or the moisture absorbent material faded away, baking treatment should be done by following conditions.
Baking condition: 60°C, 12hours (One time only).

6.3 Soldering Notice and Conditions

- When soldering LEDs,
- Do not solder/reflow the same LED over two times.
- Recommend soldering conditions:
Hand soldering : 350 °C max , 3 sec. max.
Reflow soldering : Pre-heat 150 °C max , 180 sec. max.
Peak 260 °C max , 5 sec. max.
- Reflow temperature profile as below: (lead-free solder)

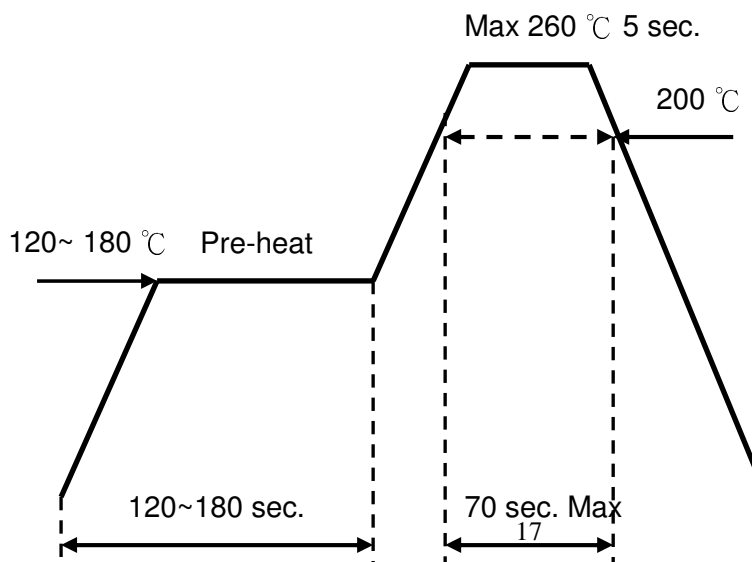

- When soldering, don't put stress on the LEDs
- After LEDs have been soldered, strongly recommend not to repair to keep the LEDs performance.

6.4 Static Electricity

- LED package is extremely sensitive to static electricity. It's recommended that anti-electrostatic glove and wrist band is necessary when handling the LEDs. All devices are also be grounded properly as well.
- Protection devices design should be considered in the LED driving circuit.

6.5 Cleaning

- If washing is required, recommend to use alcohol as a solvent.
- Recommend to avoid cleaning the LEDs by ultrasonic. If necessary, pre-test the LED is necessary to confirm whether any damage occur after the process.

Appendix:

Lextar Old/New Version Color Binning Comparison (5700K→5000K→4000K→3500K→3000K→2700K)

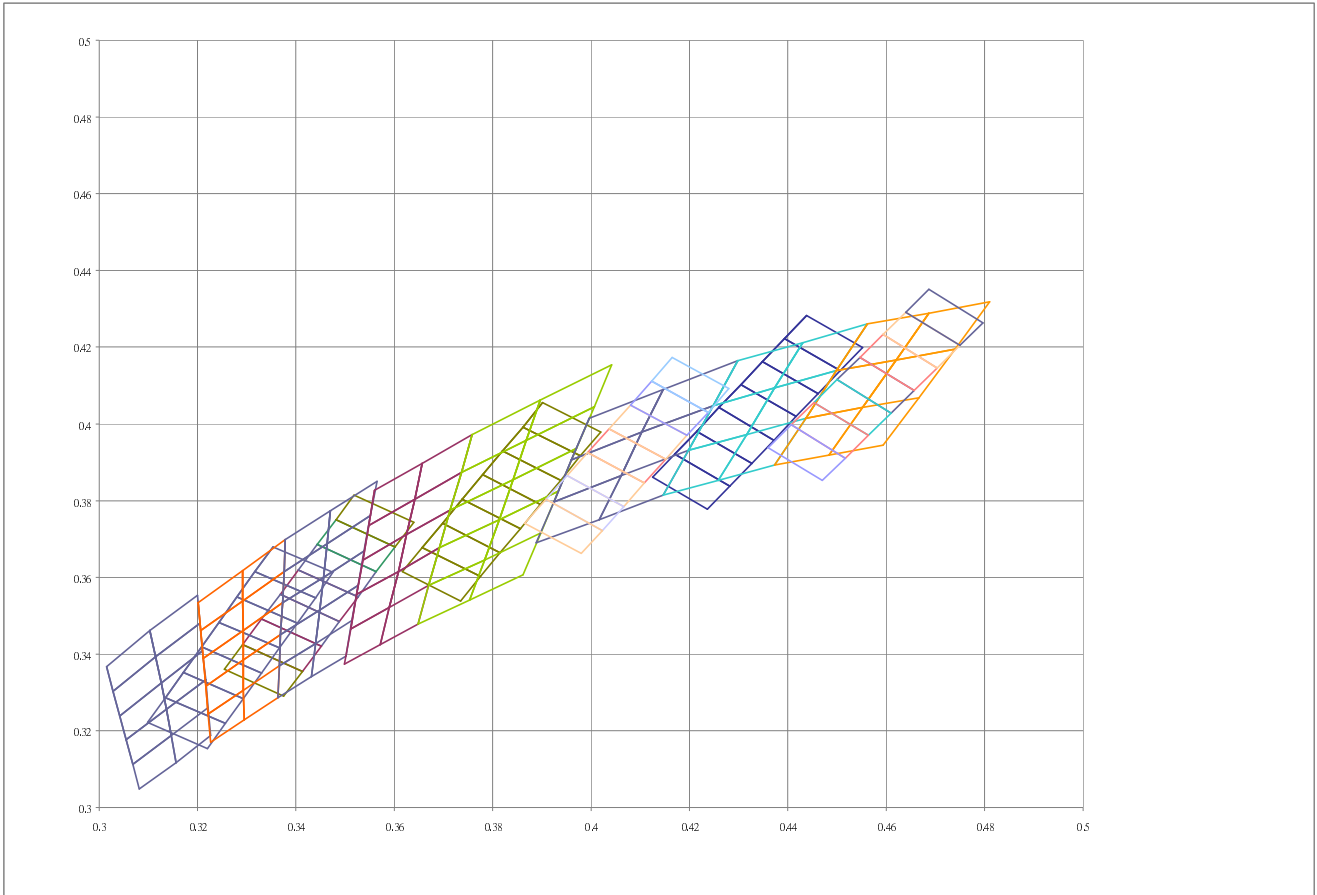

单击下面可查看定价，库存，交付和生命周期等信息

[>>Lextar\(隆达\)](#)