

REVISIONS					
REV	ECO	DESCRIPTION	DATE	BY	APPR
B1	-	RELEASED DRAWING	AUG-18-2014	BEN	TOMMY

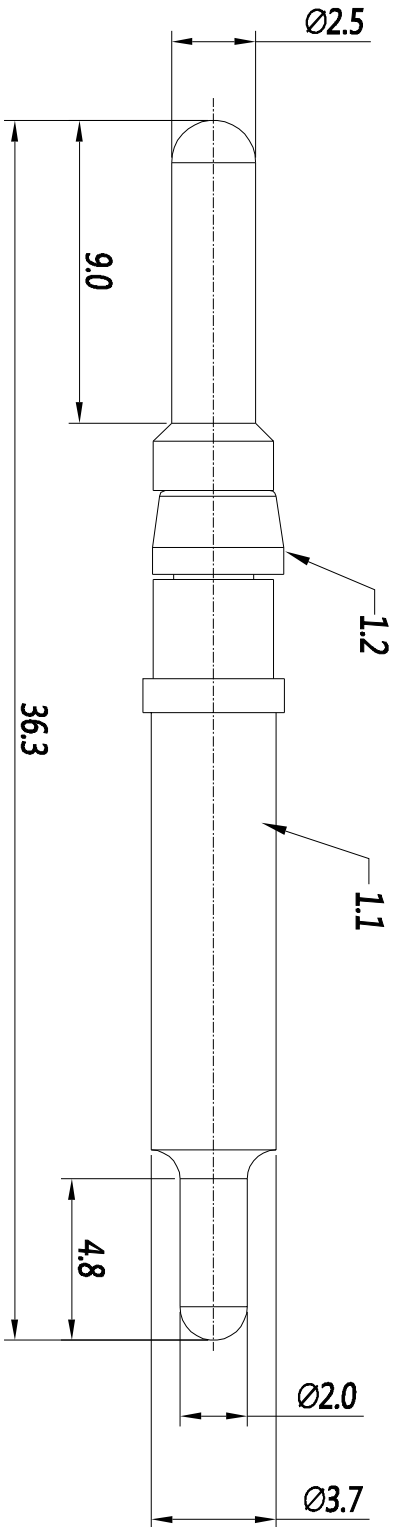

- NOTES : (UNLESS OTHERWISE SPECIFIED)
- MATERIAL :
 - CONTACT BODY : COPPER ALLOY.
 - POSITIONING CLIP : COPPER ALLOY.
 - SPECIFICATIONS :
 - CURRENT RATING : 23A(MAX).
 - TERMINATION TYPE : SOLDER.
 - ROHS COMPLIANT.
 - ALL DIMENSIONS ARE FOR REFERENCE USE ONLY.

P/N	DESCRIPTION	QTY
MP10B12E05F	CONTACT PLATING(MATING AREA)	
MP10B12E05F	GOLD FLASH PLATING OVER NICKEL.	
MP10B12E05G5	5µ" GOLD PLATING OVER NICKEL.	
MP10B12E05G10	10µ" GOLD PLATING OVER NICKEL.	
MP10B12E05G15	15µ" GOLD PLATING OVER NICKEL.	
MP10B12E05G30	30µ" GOLD PLATING OVER NICKEL.	

QUANTITY	PART NUMBER	DESCRIPTION	ITER
MATERIALS LIST			
UNLESS OTHERWISE SPECIFIED			
1) ALL DIMENSIONS ARE IN MILLIMETERS UNLESS OTHERWISE SPECIFIED.			
2) TOLERANCES ARE AS SHOWN.			
3) HOLE REFERENCE = Δ			
DRAWN: BEN		DATE: 11/27/11	
CHECKED: FREDERICK S. VIDA		ENGINEER: [blank]	
APPROVAL: [blank]		CUSTOMER: [blank]	
MATERIAL SPECIFICATIONS: [blank]		PROCESS SPECIFICATIONS: [blank]	
NEXT ASST: [blank]		THIS DRAWING IS SUPPLIED FOR SPECIFICATIONS AND PERFORMANCE DATA. THE MANUFACTURER ASSUMES ALL RESPONSIBILITIES FOR THE INFORMATION CONTAINED HEREIN. ALL RIGHTS OF REPRODUCTION ARE RESERVED. ALL MANUFACTURING VARIATIONS.	
SCALE: NONE		SIZE: B	
MACHINE: SOLDER, 2.50mm.		DWG NO: MP10B12E05xx	
ECO-MATE PIN CONTACT,		REVISION: B1	
SHEET 1 OF 1		DRAWING: Amphenol	
Shine Systems - www.amphenol-shine.com		44724 Morley Drive	
Clinton Township, MI 48038			

单击下面可查看定价，库存，交付和生命周期等信息

[>>Amphenol\(安费诺\)](#)