

## 一、Mechanical Dimensions

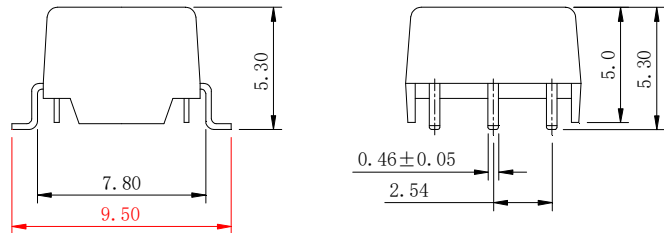

### SUGGESTED PAD LAYOUT

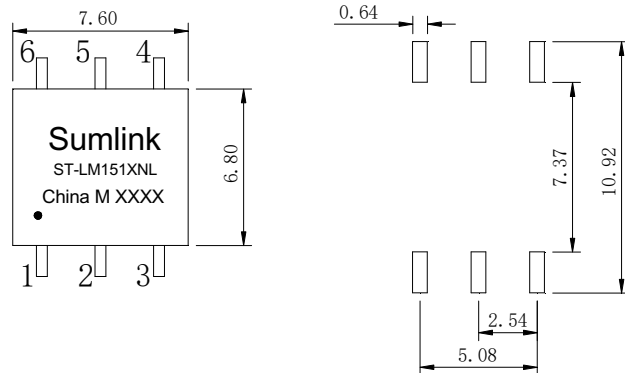

UNIT:mm Unless otherwise specified.all tolerances are $\pm 0.25$

## 二、Schematics

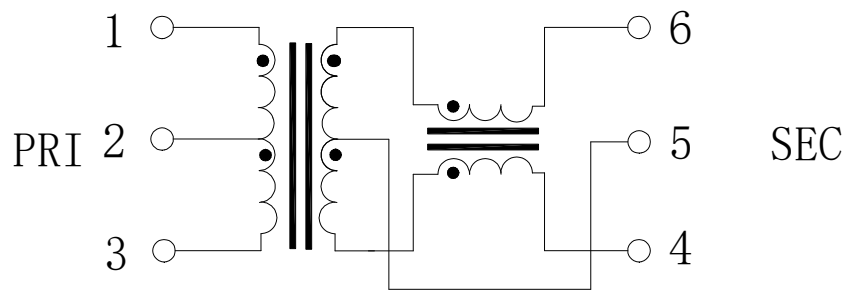

## 三、ELECTRICAL SPECIFICATIONS@25°C:

1. Turn Ratio( $\pm 2\%$ ): 1CT:1CT
2. OCL(100KHz/0.1V):150uH MIN
3. LL(100KHz/0.1V):0.5 uH MAX
4. Pri DCR:**0.45**  $\Omega$  MAX
5. Sec DCR:**0.85**  $\Omega$  MAX
6. Insertion Loss (dB MAX):**-0.25**dB(4MHz)
7. Return Loss(dB MIN): -20dB(4MHz)
8. CMR(dB **TYP**): -35dB(1~10MHz),-20dB(10-1000MHz)
9. HI-POT:4300VDC/0.5mA/60Sec
10. Operating Temperature: -40°C ~+125°C
11. RoHS compliance:YES

REV.	DESCRIPTION	DATE	DWN	AP'PD
1.0		17.10.19	Zhou	Hsu
1.1	Correct Characteristic	17.10.31	Zhou	Hsu
1.2	Correct Appearance	17.12.18	Zhou	Hsu

Ref: HM2103NL

**Sumlink**<sup>®</sup>

深圳市赛铭鑫科技开发有限公司  
Sumlink Technology Co., Ltd.



RoHS Compliant	TITLE	TRANSFORMER		
	P/N	ST-LM151XNL	REV.	1.2
	PAGE NO	1-3	DATE	2017-12-18
	AP'PD	Hsu	DWN	Zhou sheng mei

四、 Our RoHS parts just can withstand IR Reflow peak temperature: 245degC+/-5degC as the following profile:

REV.	DESCRIPTION	DATE	DWN	AP'PD

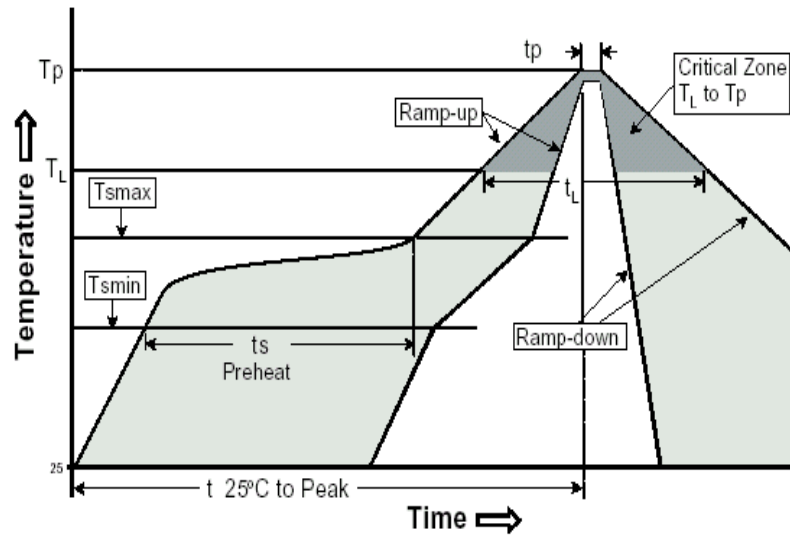

Profile Feature	Pb-Free Assembly
Average Ramp-Up Rate ( $T_{smax}$ to $T_p$ )	3°C /second max.
<b>Preheat</b> -Temperature Min ( $T_{smin}$ ) -Temperature Max ( $T_{smax}$ ) -Time ( $t_{smin}$ to $t_{smax}$ )	150°C 200°C 60-120 seconds
<b>Time maintained above:</b> -Temperature ( $T_L$ ) -Time ( $t_L$ )	217°C 60-150 seconds
Peak/Classification Temperature ( $T_p$ )	245±5°C
Time within 5°C of actual Peak Temperature ( $t_p$ )	20-40 seconds
Ramp-Down Rate	6°C/seconds max
Time 25°C to Peak Temperature	8 minutes max.

**Sumlink®**

深圳市赛铭鑫科技开发有限公司  
**Sumlink Technology Co., Ltd.**



TITLE	TRANSFORMER		
P/N	ST-LM151XNL	REV.	1.2
PAGE NO	2-3	DATE	2017-12-18
AP'PD	Hsu	DWN	Zhou sheng mei

## 五、 Packing Information:

REV.	DESCRIPTION	DATE	DWN	AP'PD

- 1.Weight-----0.44 grams/pcs
- 2.Tape & Reel----- 800 pcs
3. outer carton unit: 8000pcs/box
4. outer carton unit: 10 T&R/box
- 5.Weight: 9.1kg per carton

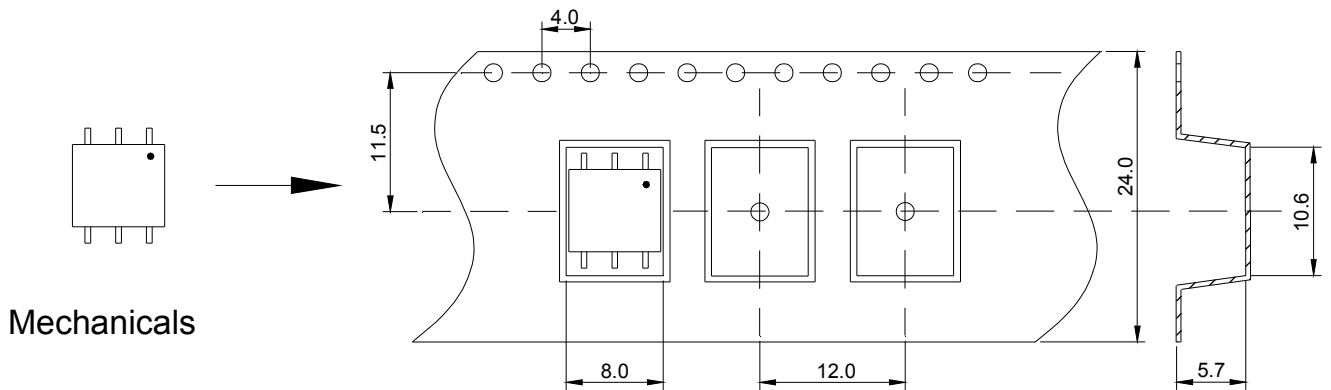

Mechanicals

Tape & Reel

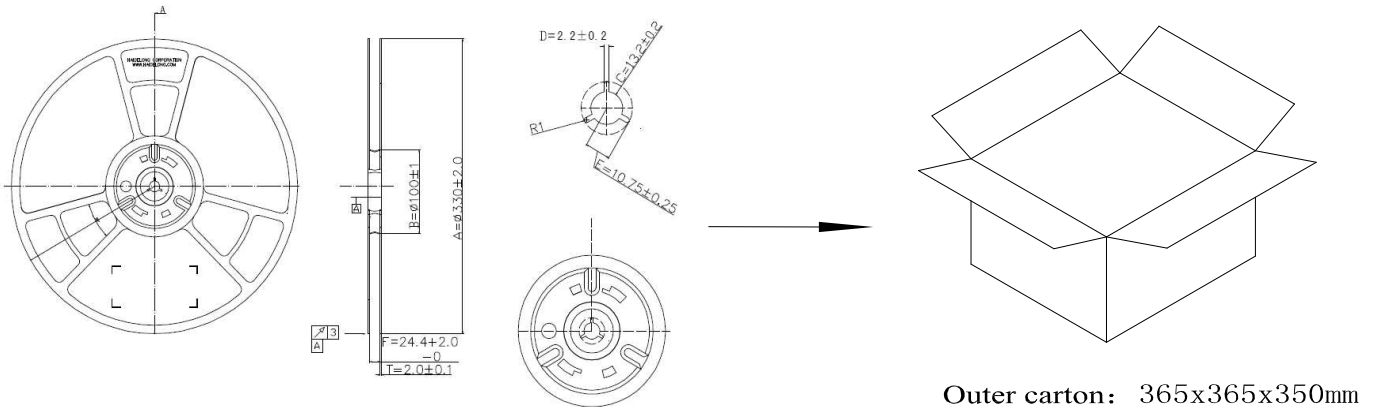

Outer carton: 365x365x350mm

**Sumlink®**

深圳市赛铭鑫科技开发有限公司  
Sumlink Technology Co., Ltd.



RoHS Compliant	TITLE	TRANSFORMER		
	P/N	ST-LM151XNL	REV.	1.2
	PAGE NO	3-3	DATE	2017-12-18
	AP'PD	Hsu	DWN	Zhou sheng mei

单击下面可查看定价，库存，交付和生命周期等信息

[>>sumlink\(赛铭鑫\)](#)