



VIC5113



Ultra-Small High-Precision Voltage Detector

● Features

Ultra-low current consumption: 1.0 μ A@3.5V(typ)

High-precision detection voltage: $\pm 2.0\%$

Hysteresis characteristics: -VDET $\times 5\%$ (typ)

Operating voltage range: 0.95 V to 8.0 V

Detection voltage: 1.5V to 6.0 V (0.1 V step)

Output forms:

NMOS open-drain output (Active Low)

CMOS output (Active Low)

● Applications

Memory battery back-up circuits

Power-on reset circuits

Power failure detection

Power monitor for portable equipment such as notebook computers, digital cameras, PDA, and cellular phones.

Constant voltage power monitors for cameras, video equipment and communication devices.

Power monitor for microcomputers and reset for CPUs.

● General Description

The VIC5113 Series is a series of high-precision voltage detectors developed using CMOS process. The detection voltage is fixed internally, with an accuracy of $\pm 2.0\%$. Two output forms, Nch open-drain and CMOS output, are available.

● Ordering Information

VIC5113-①②③④⑤⑥

DESIGNATOR	SYMBOL	DESCRIPTION
①②③	Output Detection Voltage200=2.0V, 250=2.5V, 263=2.63V 293=2.93V%0.1V step)
④	Pin Type:	A: Normal; B: B-Type
⑤⑥	Package Type:	DT:SOT343、DI: SOT23、DM:SOT89、DK:SOT23-5



VIC5113



● Absolute Maximum Ratings

Item	Symbol	Absolute maximum ratings	Unit	
Power supply voltage	VDD	VSS-0.3 ~ VSS+10	V	
Output voltage	VOUT	VSS-0.3 ~ VSS+10	V	
Power dissipation	SOT-23-3 SOT-89 TO-92 SOT343	PD	250	mW
			500	mW
			500	mW
			250	mW
Operating ambient temperature	Topr	-40 ~ +85	°C	
Storage temperature	Tstg	-40 ~ +125	°C	

● Electrical Characteristics @ (TA=25°C, unless otherwise specified)

Item	Symbol	Condition	Min.	Typ.	Max.	Unit	
Detection voltage*1	-VDET	—	$-V_{DET(S)} \times 0.98$	$-V_{DET(S)}$	$-V_{DET(S)} \times 1.02$	V	
Hysteresis width	VHYS	—	$0.02 \times -V_{DET(S)}$	$0.05 \times -V_{DET(S)}$	$0.08 \times -V_{DET(S)}$	V	
Current consumption	ISS	VDD = -VDET + 0.5V	VIC5113C/N20~26	—	1.0	2.0	uA
			VIC5113C/N 26~39	—	1.2	2.5	uA
			VIC5113C/N 39~60	—	1.5	3.0	uA
Operating voltage	VDD	—	0.95	—	8	V	
Output current	IOUT	NMOS: VOUT = 0.5 V VDD = -VDET - 0.5 V	VIC5113C/N 20~26	3.0	13.0	—	mA
			VIC5113C/N 26~39	3.0	15.0	—	mA
			VIC5113C/N 39~60	3.0	18.0	—	mA
		PMOS: VDD - VOUT = 0.5 V VDD = -VDET + 0.5 V	VIC5113C/N 20~26	1.5	4.0	—	mA
			VIC5113C/N 26~39	1.5	6.0	—	mA
			VIC5113C/N 39~60	1.5	8.0	—	mA
Leakage current	I _{LEAK}	Only for NMOS open-drain output products, VDD = 8.0 V, VOUT = 8.0 V	—	—	0.1	uA	
temperature coefficient		Ta = -40°C ~ +85°C	—	±120	±360	ppm/°C	
Delay time	TD				200	uS	

● **Typical Block Diagram**

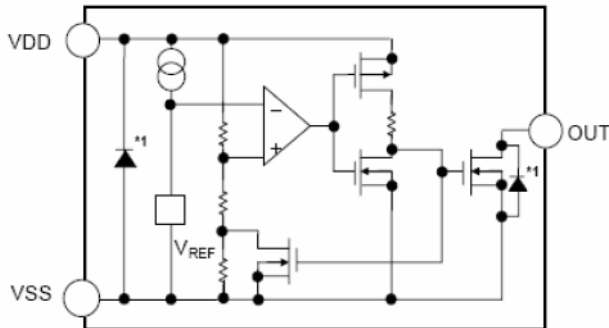

Nch open-drain

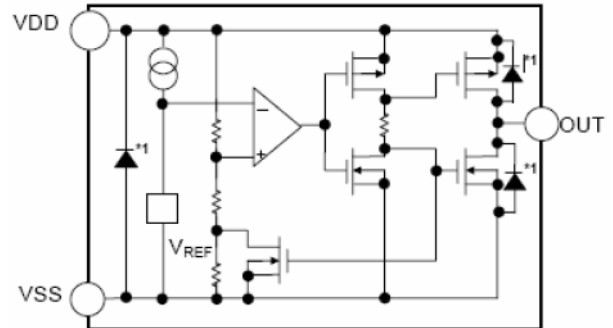

CMOS output

Note:*1-parasitic diode

● **Pin Description**

SOT-23-3
Top view

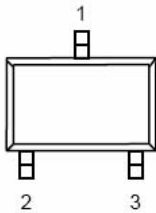

PIN NO.	A	B	Functions
1	VDD	VDD	Voltage input pin
2	VOUT	-	Voltage detection output pin
	-	VSS	GND pin
3	VSS	-	GND pin
	-	VOUT	Voltage detection output pin

SOT-89-3
Top view

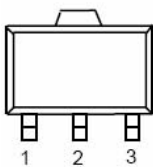

PIN NO	P	Functions
1	VOUT	Voltage detection output pin
2	VDD	Voltage input pin
3	VSS	GND pin

TO-92
Bottom view



PIN NO	T	TA	Functions
1	VOUT	-	Voltage detection output pin
	-	VDD	Voltage input pin
2	VDD	-	Voltage input pin
	-	VSS	GND pin
3	VSS	-	GND pin
	-	VOUT	Voltage detection output pin

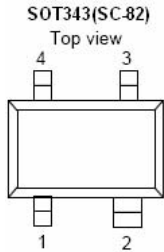

PIN NO	N	Functions
1	VOUT	Voltage detection output pin
2	VDD	Voltage input pin
3	NC	No Connection
4	VSS	GND pin

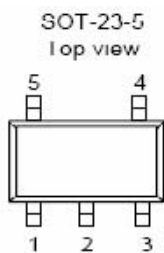

PIN NO.	MR	Functions
1	VOUT	Voltage detection output pin
2	VDD	Voltage input pin
3	VSS	GND pin
4	NC	No connection
5	NC	No connection

● Function Description

1. When a voltage higher than the release voltage (+V_{DET}) is applied to the voltage input pin (VDD), the voltage will gradually fall. When a voltage higher than the detect voltage (-V_{DET}) is applied to VDD, output (VOUT) will be equal to the input at VDD. Note that high impedance exists at VOUT with the N-channel open drain configuration. If the pin is pulled up, VOUT will be equal to the pull up voltage.
2. When VDD falls below -V_{DET}, VOUT will be equal to the ground voltage (VSS) level (detect state). Note that this also applies to N-channel open drain configurations.
3. When VDD falls to a level below that of the minimum operating voltage (V_{MIN}) output will become unstable. Because the output pin is generally pulled up with N-channel open drain configurations, output will be equal to pull up voltage.
4. When VDD rises above the VSS level (excepting levels lower than minimum operating voltage), VOUT will be equal to VSS until VDD reaches the +V_{DET} level.
5. Although VDD will rise to a level higher than +V_{DET}, VOUT maintains ground voltage level via the delay circuit.
6. Following transient delay time, VDD will be output at VOUT. Note that high impedance exists with the N-channel open drain configuration and that voltage will be dependent on pull up.

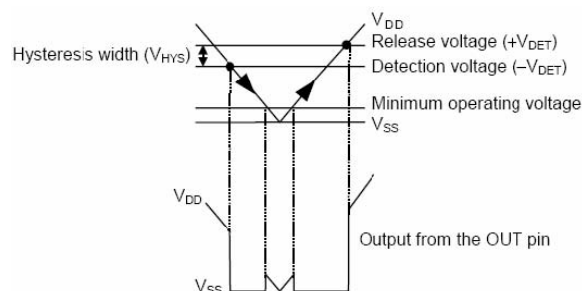

- Typical Application Circuit

1、 CMOS output:

2、

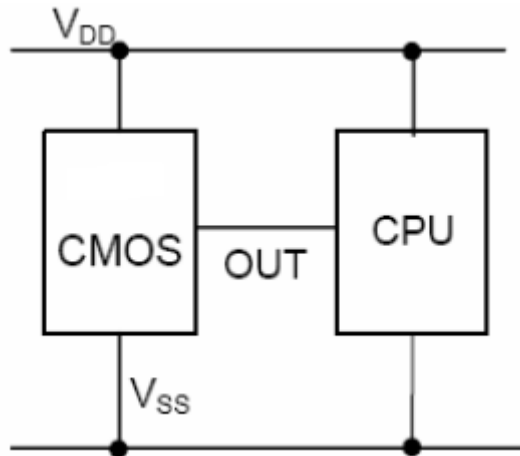

3、 Nch open-drain

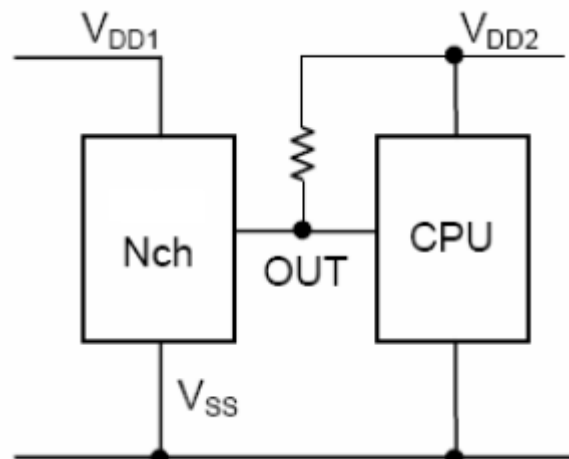
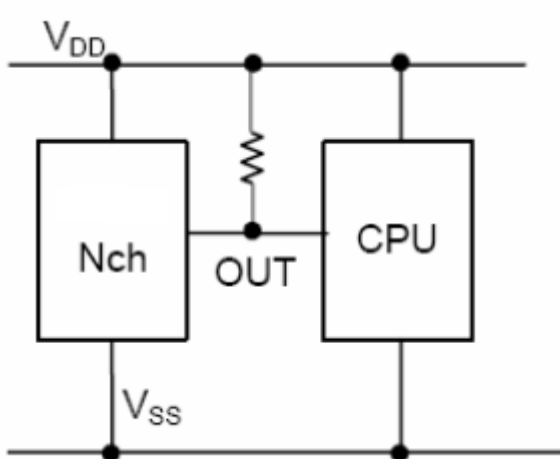



VIC5113



● Package Information

● SOT-23

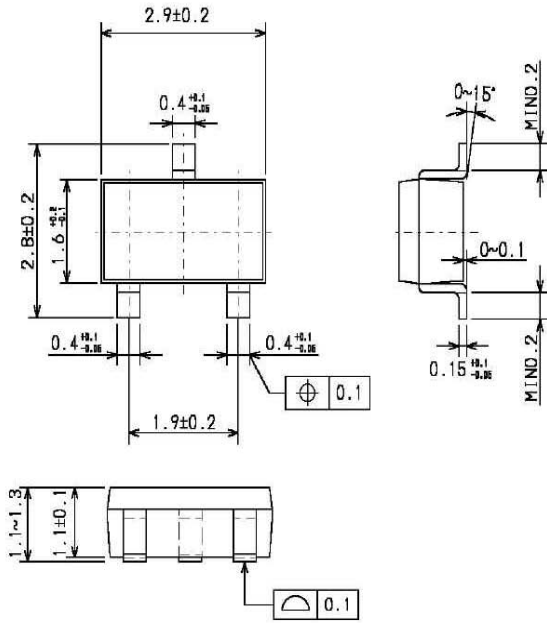

SOT23-5

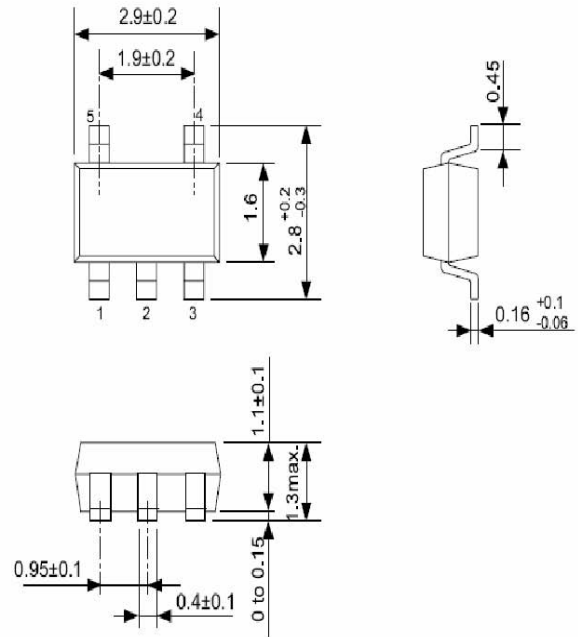

● TO-92

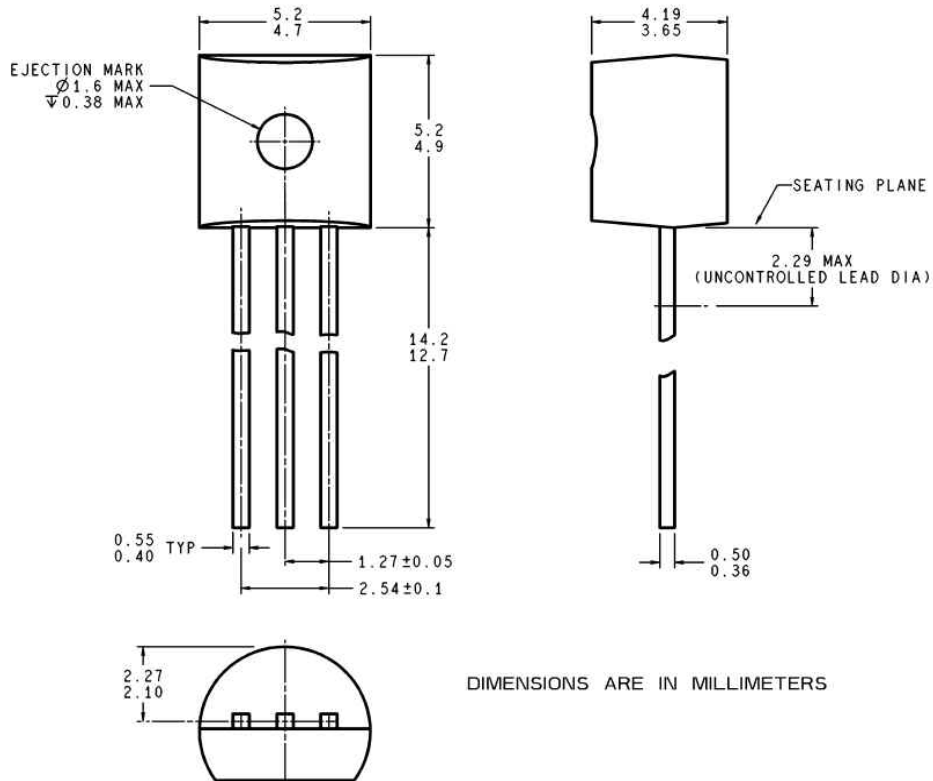

DIMENSIONS ARE IN MILLIMETERS

● SOT-89



VIC5113

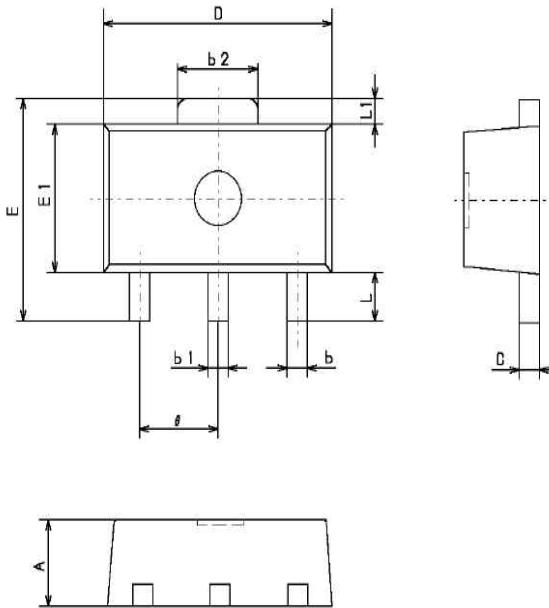

Symbols	Dimensions in millimeters		
	Min	Nom	Max
A	1.40	1.50	1.60
b	0.36	0.42	0.48
b1	0.41	0.47	0.53
b2	1.40	1.60	1.75
C	0.38	0.40	0.43
D	4.40	4.50	4.60
E	—	—	4.25
E1	2.40	2.50	2.60
θ	1.40	1.50	1.60
L	1.80	—	—
L1	—	0.40	—

• SOT343 (SC-82)

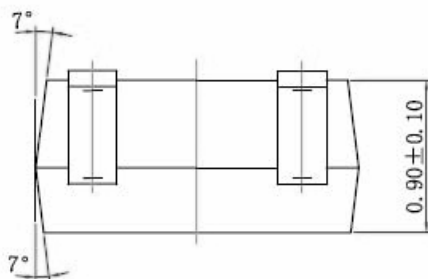
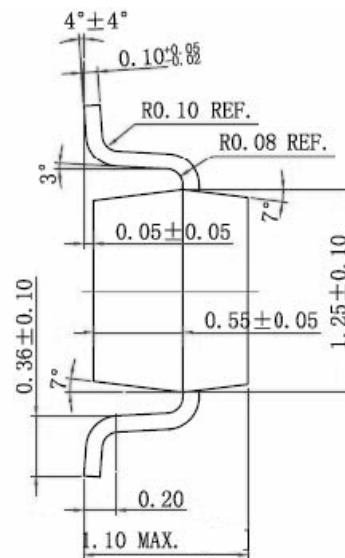
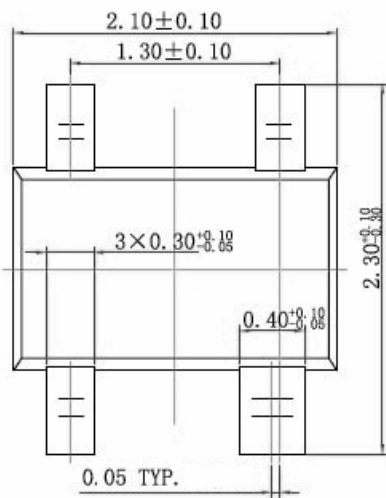



VIC5113



DISCLAIMER

VICTECH TECHNOLOGY RESERVES THE RIGHT TO MAKE CHANGES WITHOUT FURTHER NOTICE TO ANY PRODUCTS HEREIN TO IMPROVE RELIABILITY, FUNCTION OR DESIGN. VICTECH DOES NOT ASSUME ANY LIABILITY ARISING OUT OF THE APPLICATION OR USE OF ANY PRODUCT OR CIRCUIT DESCRIBED HEREIN; NEITHER DOES IT CONVEY ANY LICIENCE UNDER ITS PATENT RIGHTS, NOR THE RIGHTS OF OTHERS.

单击下面可查看定价，库存，交付和生命周期等信息

[>>VIC\(微科\)](#)