

CPT CONNECTOR

Board-to-wire



Features

● Compact design

2.0mm pitch is realized miniaturization and low profile as the connector for automobile.

● Terminal construction

Female terminal is designed for simple box structure by having spring structure on male terminal.

Developed in pursuit of miniaturization and low profile as PC board connector for automobile.

This connector is surface mounting type connector having the spring structure on male terminal disproving the conventional concept.

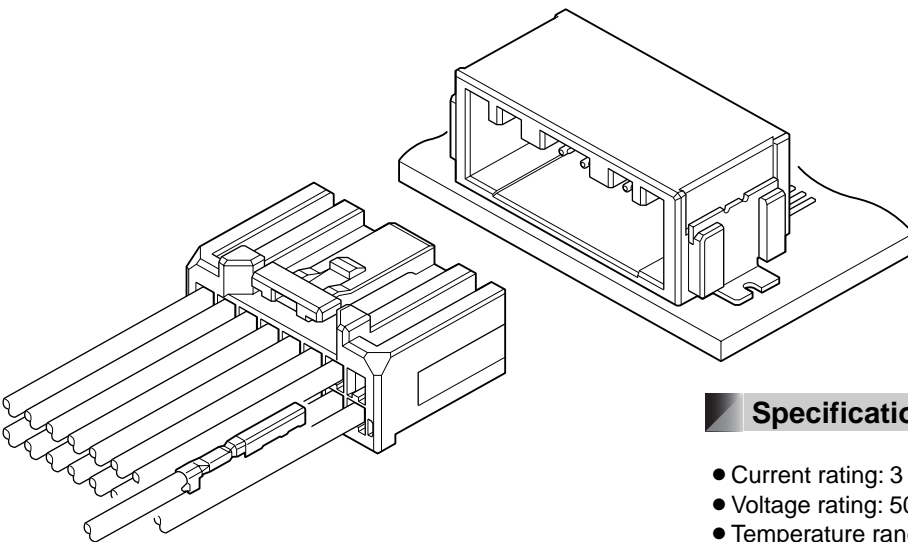

Specifications

- Current rating: 3 A AC, DC (0.3mm², Single circuit)
- Voltage rating: 50 V AC, DC
- Temperature range: -40°C to +100°C
(including temperature rise in applying electrical current)
- Contact resistance: Initial value/ 8 mΩ max.
After environmental tests/ 16 mΩ max.
- Insulation resistance: 100 MΩ min.
- Withstanding voltage: 1,000 VAC/minute
- Applicable wire: AESX-f/ AVSS
0.3 mm²

- * Compliant with ELV/RoHS.
- * Contact JST for details.

Female terminal

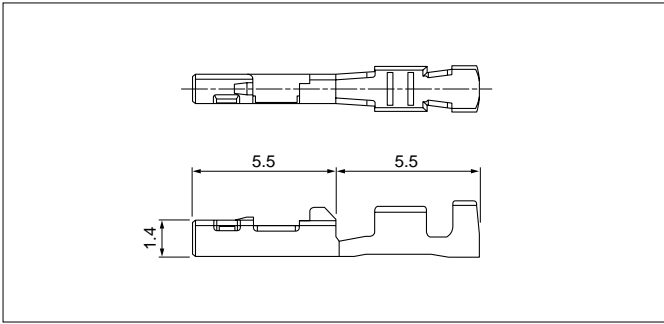

Model No.	Applicable wire range		Q'ty/reel
	Conductor (mm ²)	Insulation O.D. (mm)	
SCPT-A021GF-0.5	0.3	1.4	15,000

Material and Finish
Brass, nickel-undercoated, Contact area; gold-plated Barrel area; tin-plated

Female connector

Single row

• 2 circuits

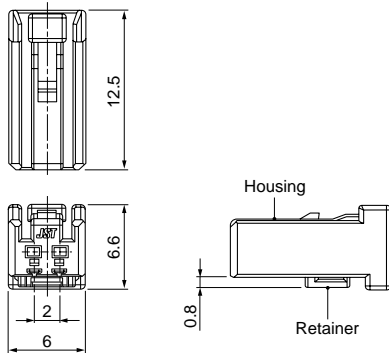

• 4 circuits

04CPT-B1-2A

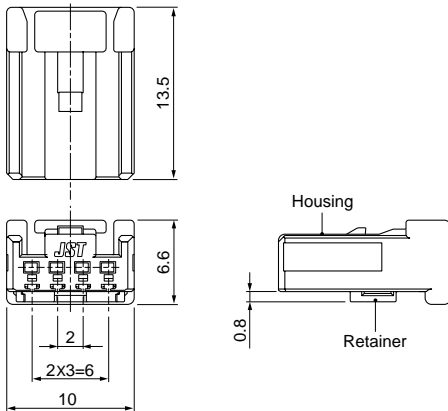

04CPT-B1-2B

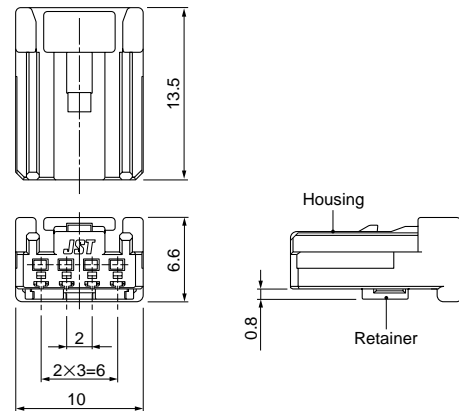

• 8 circuits

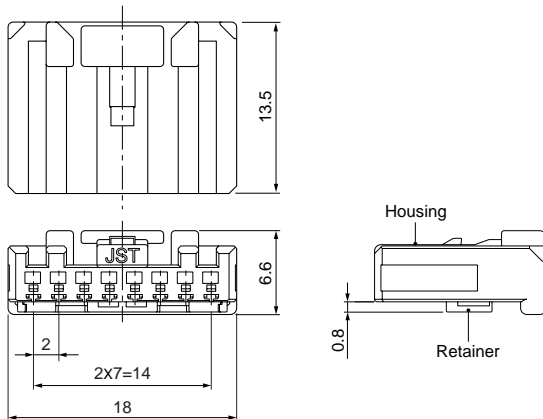

Female connector

Double row

• 8 circuits

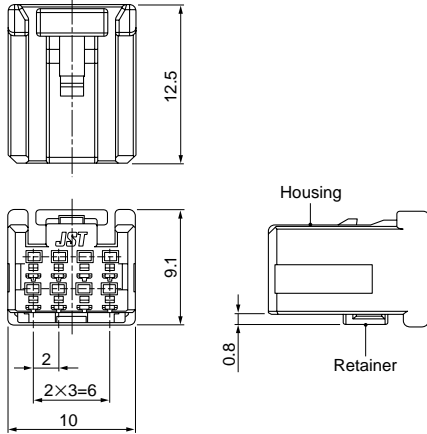

• 20 circuits

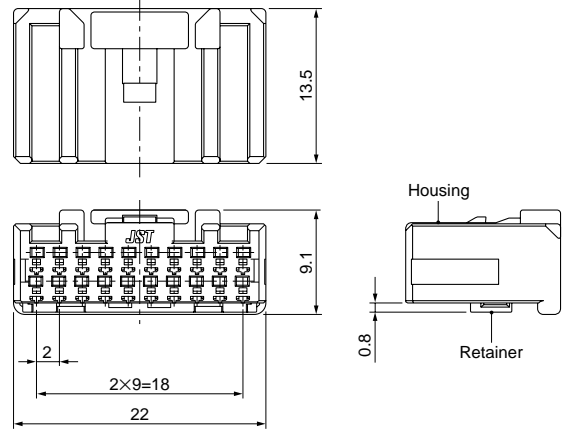

• 12 circuits

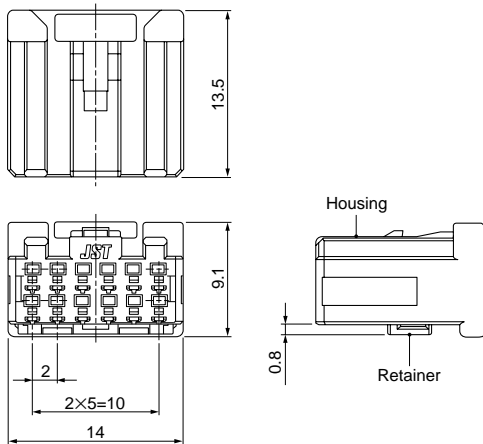

• 24 circuits

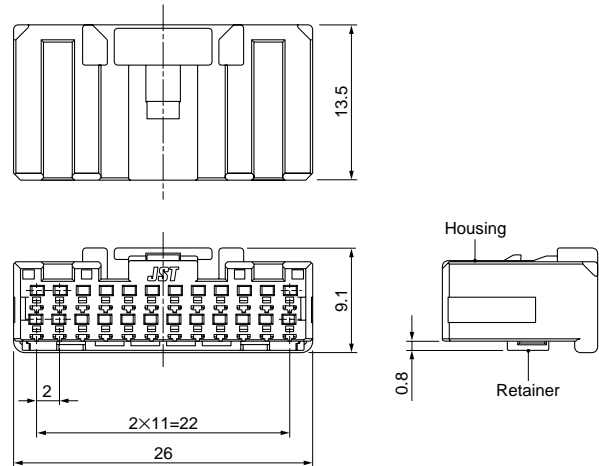

• 16 circuits

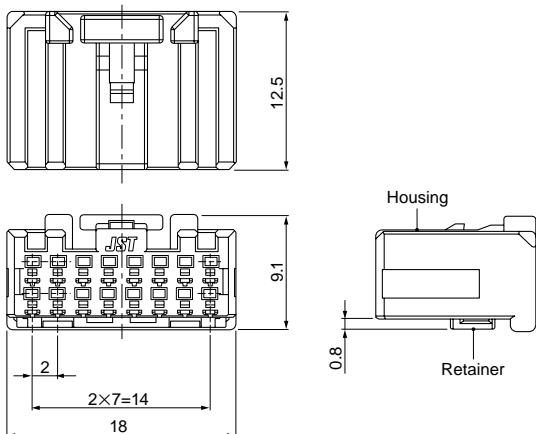

Type	Circuits	Model No.	Q'ty/box
Single row	2	02CPT-B-2A	500
	4	04CPT-B1-2A	600
		04CPT-B1-2B	
Double row	8	08CPT-B1-2A	400
	8	08CPT-B-2A	500
	12	12CPT-B-2A	300
	16	16CPT-B-2A	250
	20	20CPT-B-2A	250
	24	24CPT-B-2A	200

Material

Housing: Glass-filled PBT, black
Retainer: Glass-filled PBT, blue

Male connector

Top entry type

Single row
● 2 circuits

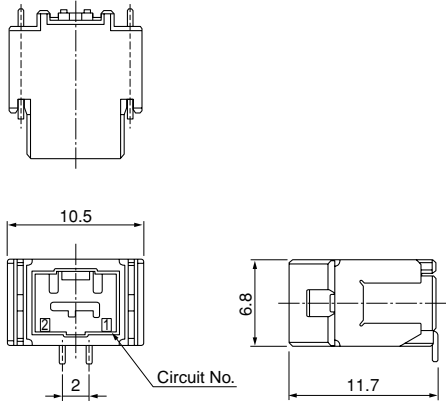

Double row
● 8 circuits

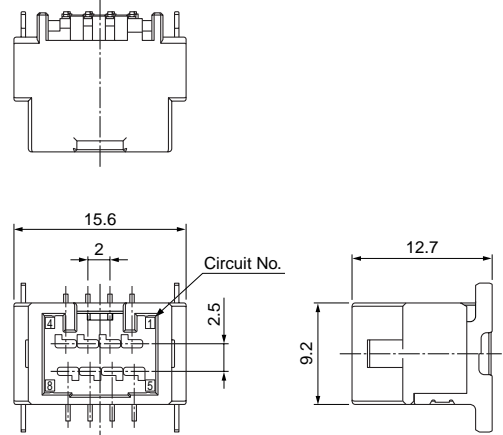

Side entry type

Single row
● 2 circuits

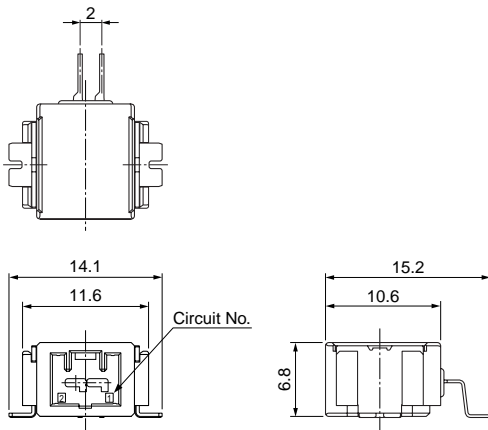

● 4 circuits

SM04B1-CPTK-1A-TB

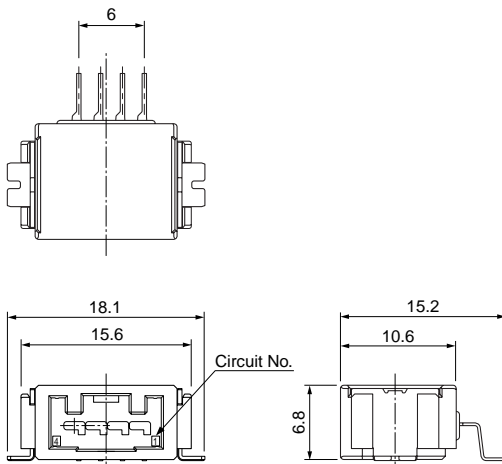

SM04B1-CPTK-1B-TB

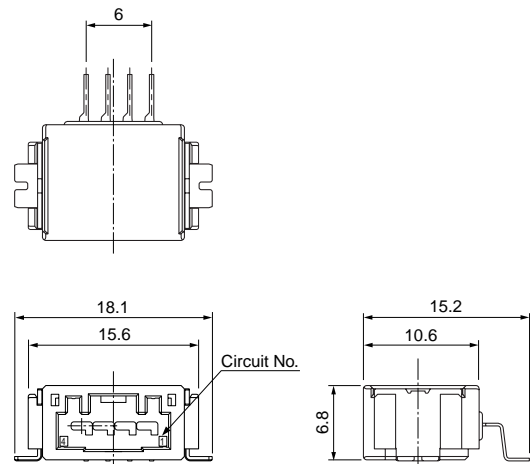

Male connector

Side entry type Single row

• 8 circuits

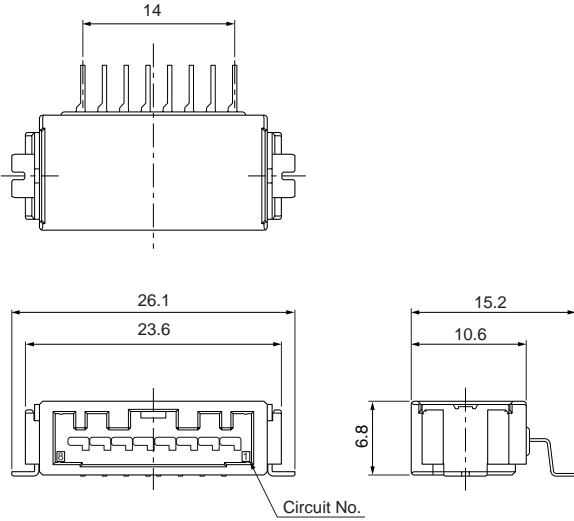

• 12 circuits

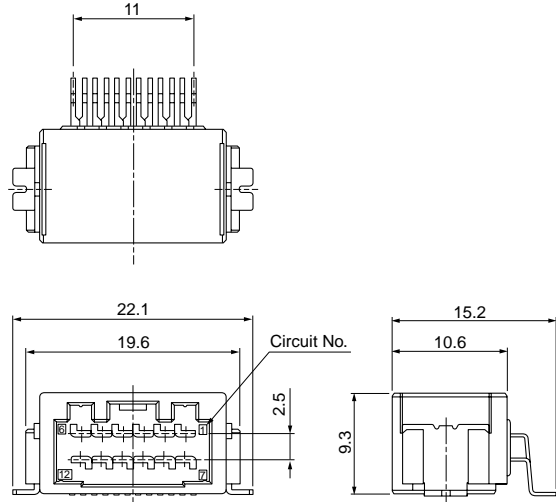

• 20 circuits

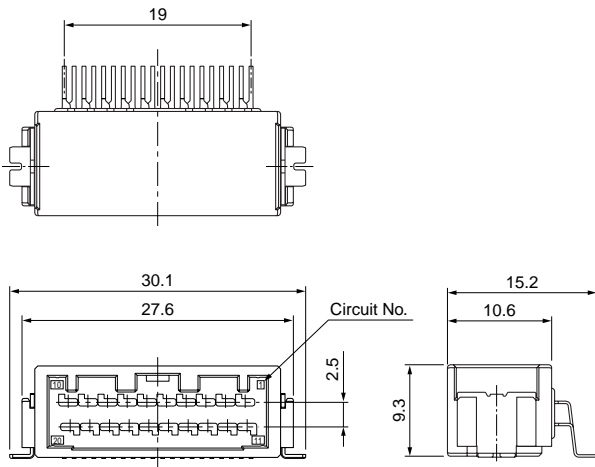

Male connector

Side entry type

Double row

• 8 circuits

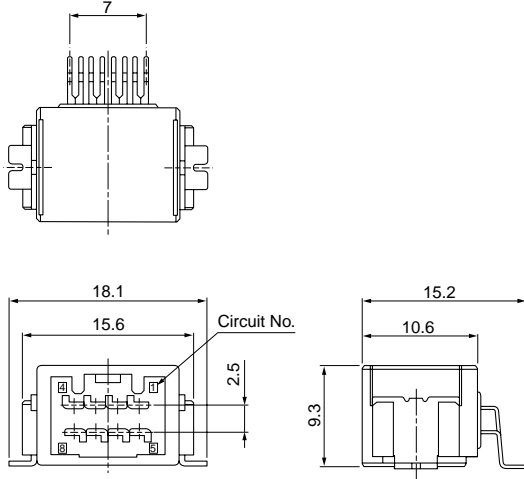

• 16 circuits

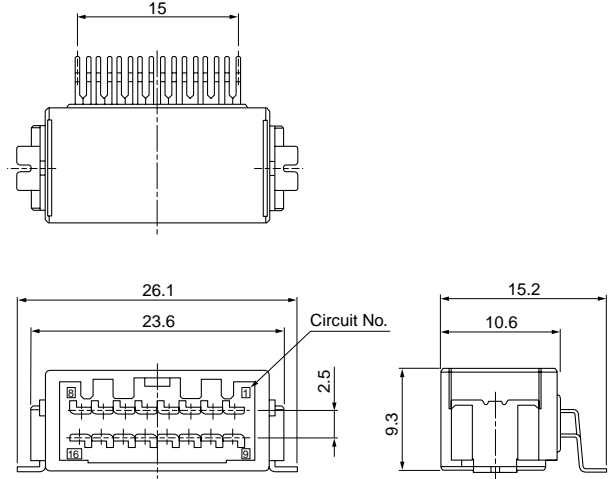

• 24 circuits

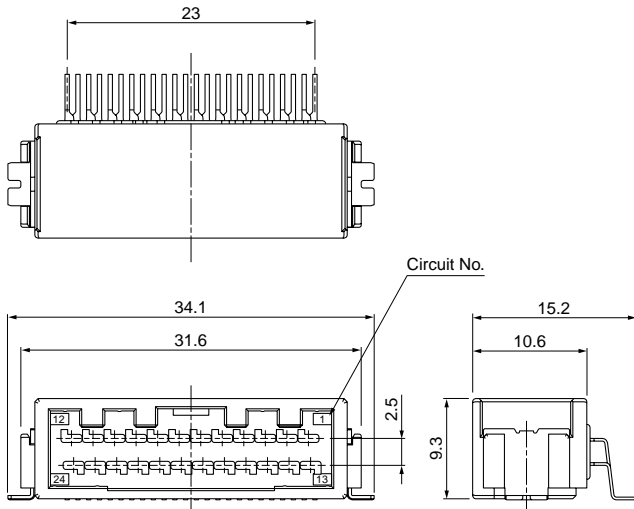

Type	Circuits	Model No.	Q'ty/reel
Top type	2 (Single)	BM02B-CPTK-1A-TB	370
	8 (Double)	BM08B-CPTK-1A-TB	240
Side type	2 (Single)	SM02B-CPTK-1A-TB	500
	4 (Single)	SM04B1-CPTK-1A-TB	500
		SM04B1-CPTK-1B-TB	
	8 (Single)	SM08B1-CPTK-1A-TB	500
	8 (Double)	SM08B-CPTK-1A-TB	390
	12 (Double)	SM12B-CPTK-1A-TB	390
	16 (Double)	SM16B-CPTK-1A-TB	390
	20 (Double)	SM20B-CPTK-1A-TB	390
24 (Double)	SM24B-CPTK-1A-TB	390	

Material and Finish

Terminal: Copper alloy, nickel-undercoated,
Contact area; gold-plated
Solder tail; tin-plated (reflow treatment)

Housing: Glass-filled LCP, black

Peg: Brass, nickel-undercoated, tin-plated (reflow treatment)

Taping Specifications

Top entry type

• 2, 8 circuits

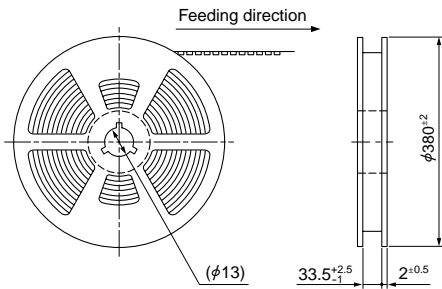

• 2 circuits

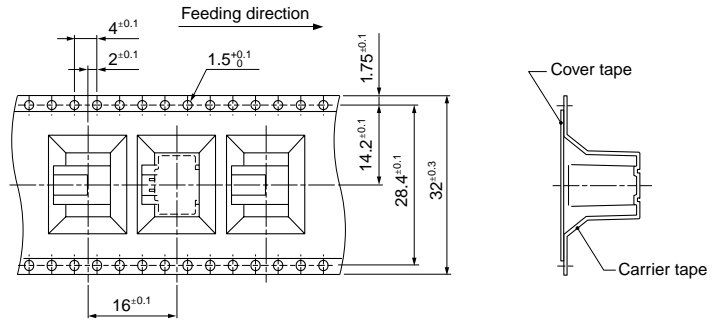

• 8 circuits

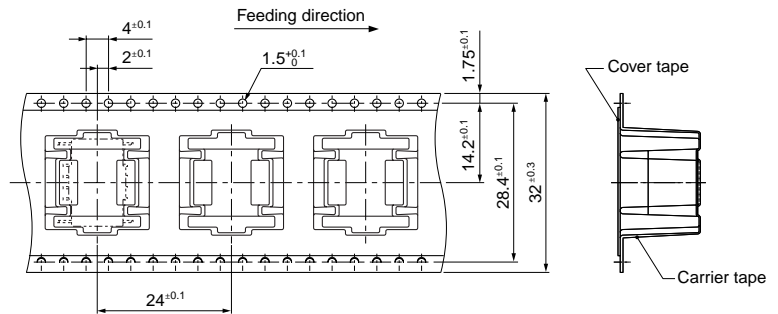
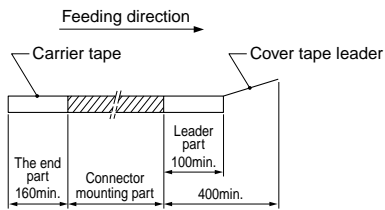

Side entry type

• 2, 4, 8, 12, 16, 20, 24 circuits

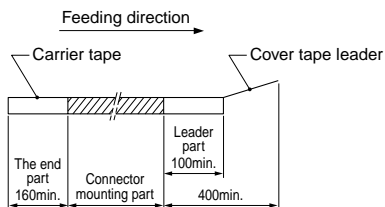
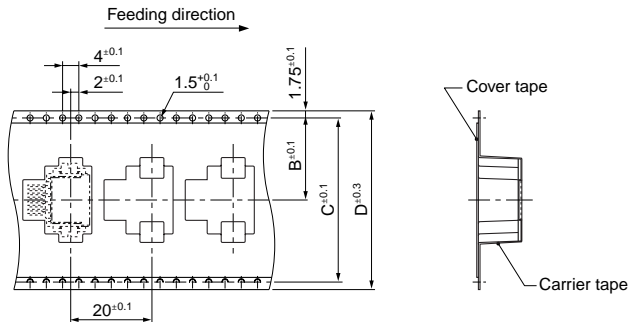
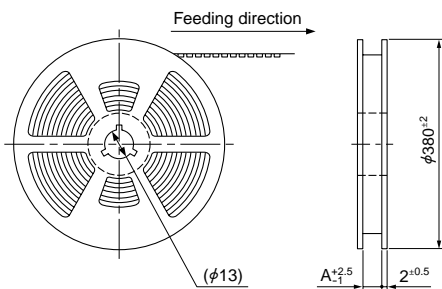

Type	Circuits	A	B	C	D
Single	2	33.5	14.2	28.4	32
	4	33.5	14.2	28.4	32
	8	45.5	20.2	40.4	44
Double	8	45.5	20.2	40.4	44
	12	45.5	20.2	40.4	44
	16	45.5	20.2	40.4	44
	20	45.5	20.2	40.4	44
	24	57.5	26.2	52.4	56

PC board layout, Assembly layout

Top entry type

● 2 circuits

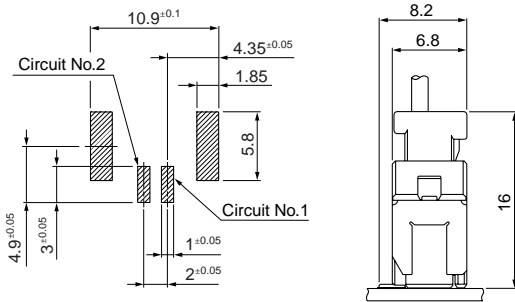

● 8 circuits

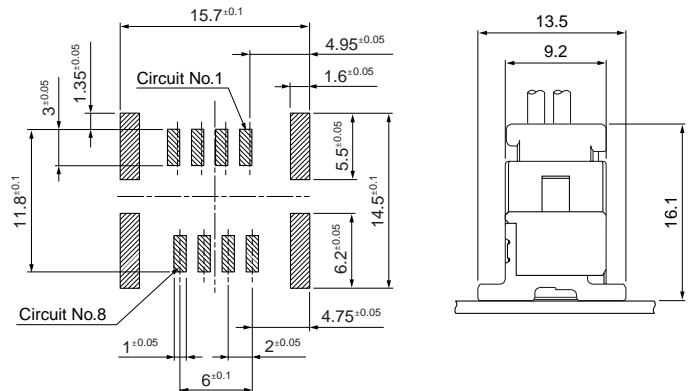

Side entry type

● 2, 4, 8 (Single) circuits

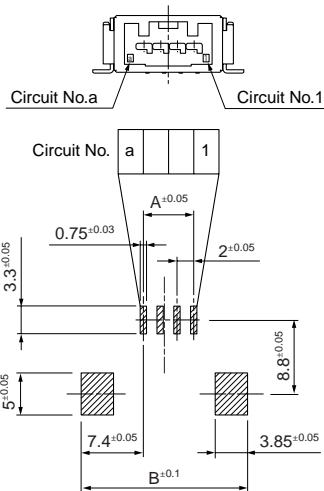

Circuits	A	B
2	2	15.8
4	6	19.8
8 (Single)	14	27.8

● 2 circuits

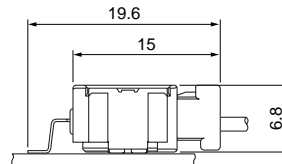

● 4 circuits

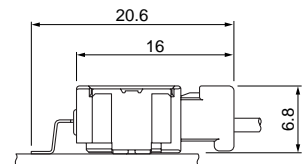

● 8 (Single) circuits

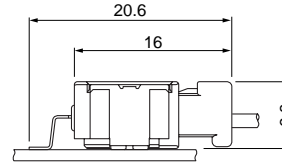

● 8 (Double), 12, 16, 20, 24 circuits

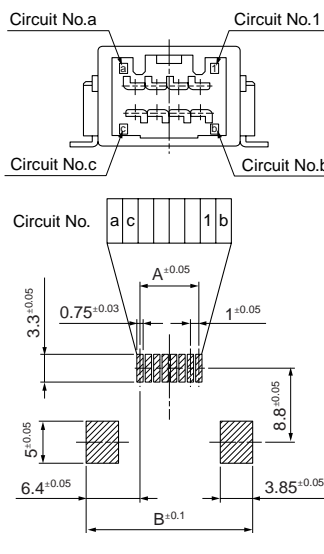

Circuits	A	B
8 (Double)	7	19.8
12	11	23.8
16	15	27.8
20	19	31.8
24	23	35.8

● 8 (Double) circuits

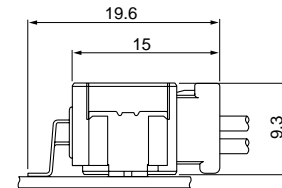

● 12 circuits

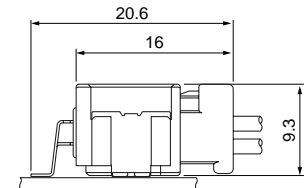

● 16 circuits

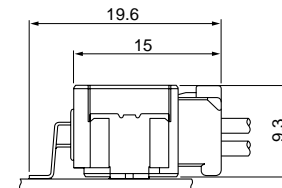

● 20, 24 circuits

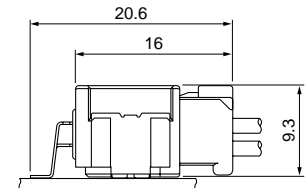

Note: 1. Tolerances are non-cumulative: ±0.05mm for all centers.
2. The dimensions above should serve as guideline. Contact JST for details.

Crimping machine, Applicator

Strip terminal	Crimping machine	Crimp applicator MKS-L	
		Dies	Crimp applicator with dies
SCPT-A021GF-0.5	AP-K2N	MK/SCPT-A021-05	APLMK SCPT-A021-05

Note: When crimping operation is conducted using an applicator, the manufacturer does not guarantee the performance of the terminal.

单击下面可查看定价，库存，交付和生命周期等信息

[>>JST\(日本压着端子製造株式会社\)](#)