



ISO9001 & ISO14001 & TS16949 **CHILISIN ELECTRONICS CORP.**

RoHS & Halogen Free & REACH Compliance.

SPECIFICATION FOR APPROVAL

Customer : _____

Customer P/N: _____

Drawing No : _____

Quantity : 0 Pcs. Date : 2015/02/03

Chilisin P/N : CLH1005T-27NJ-H

SPECIFICATION ACCEPTED BY:	
COMPONENT ENGINEER	
ELECTRICAL ENGINEER	
MECHANICAL ENGINEER	
APPROVED	
REJECTED	

<p>奇力新電子股份有限公司 Chilisin Electronic sCorp No. 29, Alley 301, Tehhsin Rd., Hukou,Hsinchu 303, Taiwan TEL : +886-3- 599-2646 FAX : +886-3- 599-9176 E-mail : sales@chilisin.com.tw http : //www.chilisin.com.tw</p>	<p>東莞奇力新電子有限公司 Chilisin Electronics (Dongguan) Co., Ltd. No. 78, Puxing Rd., Yuliangwei Administration Area, Qingxi Town, Dongguan City, Guangdong,China TEL : +86-769-8773-0251~3 FAX : +86-769-8773-0232 E-mail : cect@chilisin.com.tw</p>
<p>奇力新電子(河南)有限公司 Chilisin Electronics (Henan) Co., Ltd. XiuWu Xian, industry gathering area JiaoZuo, Henan China Postal Code:454350 TEL:+86-391-717-0682 FAX:+86-391-717-0666</p>	<p>奇力新電子(蘇州)有限公司 Chilisin Electronics (Suzhou) Co., Ltd. No.143,Song Shan Rd., Suzhou New District, Suzhou,China Postal Code:215129 TEL:+86-512-6841-2350 FAX:+86-512-6841-2356</p>

Drawn by 陳瑞揚 ryan.chen	Checked by 邱明傑 Joseph.Chiu	Approved by 陳瑞揚 ryan.chen
----------------------------------	--------------------------------------	-------------------------------------

YG15200256

CLH1005T Series Specification

1 Scope: This specification applies to Multilayer ceramic chip inductors

2 Part Numbering:

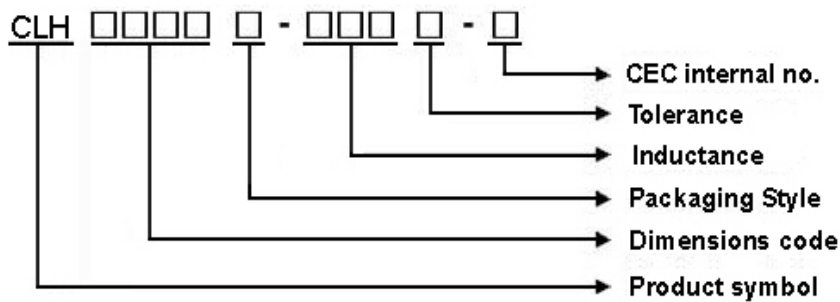

3 Rating:

Operating Temperature: $-55^{\circ}\text{C} \sim 125^{\circ}\text{C}$ (Including self - temperature rise)

Storage Temperature: $-55^{\circ}\text{C} \sim 125^{\circ}\text{C}$ (after PCB)

$-5^{\circ}\text{C} \sim 40^{\circ}\text{C}$, Humidity 40%~70% (before PCB)

4 Marking:

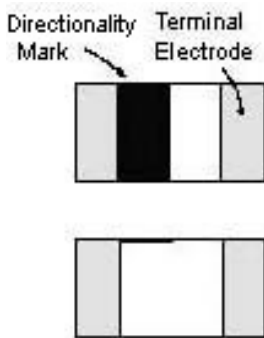

5 Standard Testing Condition

	Unless otherwise specified	In case of doubt
Temperature	Ordinary Temperature(15 to 35°C)	20±2°C
Humidity	Ordinary Humidity(25 to 85% RH)	60 to 70 % RH

CLH1005T Series Specification

6 Configuration and Dimensions:

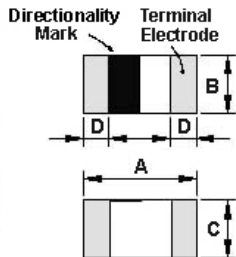

Dimensions in mm

TYPE	CLH1005
A	1.00±0.10
B	0.50±0.10
C	0.50±0.10
D	0.25±0.10

7 Electrical Characteristics:

Part No.	Inductance (nH)	L,Q Test Freq.	Q Min.	SRF (MHz)Typ.	RDC (Ω)Max.	IDC (mA)Max.	Tolerance
CLH1005T-1N0□-H	1	100 MHz,200 mV	8	10000	0.07	400	S
CLH1005T-1N2□-H	1.2	100 MHz,200 mV	8	10000	0.09	400	S
CLH1005T-1N5□-H	1.5	100 MHz,200 mV	8	9000	0.1	400	S
CLH1005T-1N8□-H	1.8	100 MHz,200 mV	8	8700	0.1	400	S
CLH1005T-2N2□-H	2.2	100 MHz,200 mV	8	8100	0.12	400	S
CLH1005T-2N7□-H	2.7	100 MHz,200 mV	8	7700	0.15	400	S
CLH1005T-3N0□-H	3	100 MHz,200 mV	8	6300	0.15	400	S
CLH1005T-3N3□-H	3.3	100 MHz,200 mV	8	6300	0.15	400	S
CLH1005T-3N9□-H	3.9	100 MHz,200 mV	8	6100	0.18	400	S,K
CLH1005T-4N7□-H	4.7	100 MHz,200 mV	8	6000	0.18	400	S,K
CLH1005T-5N6□-H	5.6	100 MHz,200 mV	8	5100	0.2	400	S,J,K
CLH1005T-6N8□-H	6.8	100 MHz,200 mV	8	4550	0.24	400	J,K
CLH1005T-8N2□-H	8.2	100 MHz,200 mV	8	4100	0.24	300	J,K
CLH1005T-10N□-H	10	100 MHz,200 mV	8	3900	0.26	300	J,K
CLH1005T-12N□-H	12	100 MHz,200 mV	8	3000	0.4	300	J,K
CLH1005T-15N□-H	15	100 MHz,200 mV	8	2800	0.5	300	J,K
CLH1005T-18N□-H	18	100 MHz,200 mV	8	2500	0.55	300	J,K
CLH1005T-22N□-H	22	100 MHz,200 mV	8	2200	0.7	300	J,K
CLH1005T-27N□-H	27	100 MHz,200 mV	8	2000	0.8	300	J,K
CLH1005T-33N□-H	33	100 MHz,200 mV	8	1800	0.9	200	J,K
CLH1005T-39N□-H	39	100 MHz,200 mV	8	1600	1	150	J,K
CLH1005T-47N□-H	47	100 MHz,200 mV	8	1400	1.2	150	J,K
CLH1005T-56N□-H	56	100 MHz,200 mV	8	1300	1.3	150	J,K
CLH1005T-68N□-H	68	100 MHz,200 mV	8	1100	1.5	100	J,K
CLH1005T-82N□-H	82	100 MHz,200 mV	8	1000	1.6	100	J,K

NOTE: □-tolerance J=±5% / K=±10% / S=±0.3nH

- Operating temperature range - 5 5 °C ~ 1 2 5 °C (Including self - temperature rise)
- IDC: Applied the current to coils, the inductance shall be less than 10% initial value.



CLH1005T Series Specification

Part No.	Inductance (nH)	L,Q Test Freq.	Q Min.	SRF (MHz)Typ.	RDC (Ω)Max.	IDC (mA)Max.	Tolerance
CLH1005T-R10□-H	100	100 MHz,200 mV	8	900	2	100	J,K
CLH1005T-R12□-H	120	100 MHz,200 mV	8	800	2.2	100	J,K
CLH1005T-R15□-H	150	100 MHz,200 mV	8	700	3.5	100	J,K
CLH1005T-R18□-H	180	100 MHz,200 mV	8	600	3.8	100	J,K
CLH1005T-R22□-H	220	100 MHz,200 mV	8	500	4.2	100	J,K
CLH1005T-R27□-H	270	100 MHz,200 mV	8	500	4.8	100	J,K

CLH1005T Series Specification

8 CLH1005T Series

8.1 Construction:

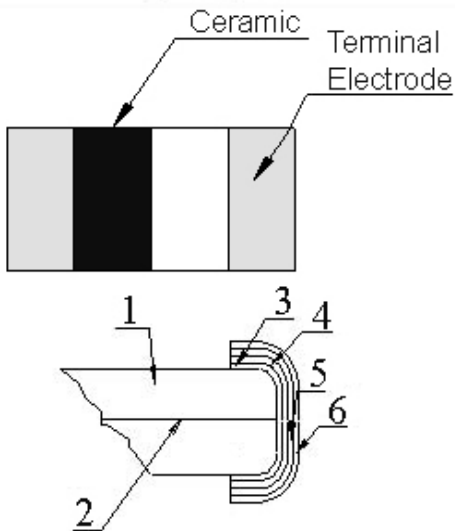

8.2 Material List:

NO	PART	MATERIAL
1	Main Substance	Al ₂ O ₃ -B ₂ O ₃ -SiO ₂
2	Silver electrode	Ag
3	Silver electrode	Ag
4	Cu plating	Cu
5	Ni plating	Ni
6	Sn plating	Sn

CLH1005T Series Specification

9 Reliability Of Ceramic Multilayer Chip Inductor For High Freq.

1-1.Mechanical Performance

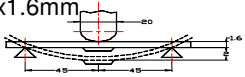
No	Item	Specification	Test Method
1-1-1	Flexure Strength	The forces applied on the right conditions must not damage the terminal electrode and the ferrite	Test device shall be soldered on the substrate Substrate Dimension: 100x40x1.6mm Deflection: 2.0mm Keeping Time: 30sec *For 100505, substrate dimension is 100x40x0.8mm 
1-1-2	Vibration		
1-1-3	Resistance to Soldering Heat	Appearance: No damage	Pre-heating: 150°C, 1min Solder Composition: Sn/Ag3.0/Cu0.5(Pb-Free) Solder Temperature: 260±5°C Immersion Time: 10±1sec
1-1-4	Solder ability	The electrodes shall be at least 95% covered with new solder coating	Pre-heating: 150°C, 1min Solder Composition: Sn/Ag3.0/Cu0.5(Pb-Free) Solder Temperature: 245±5°C (Pb-Free) Immersion Time: 4±1sec

1-2.Environmental Performance

No	Item	Specification	Test Method															
1-2-1	Temperature Cycle	Appearance: No damage Inductance: within±10% of initial value Q change: within±30% of initial value	One cycle: <table border="1" style="width: 100%; border-collapse: collapse;"> <thead> <tr> <th>Step</th> <th>Temperature (°C)</th> <th>Time (min)</th> </tr> </thead> <tbody> <tr> <td>1</td> <td>-55±3</td> <td>30</td> </tr> <tr> <td>2</td> <td>25±2</td> <td>3</td> </tr> <tr> <td>3</td> <td>125±3</td> <td>30</td> </tr> <tr> <td>4</td> <td>25±2</td> <td>3</td> </tr> </tbody> </table>	Step	Temperature (°C)	Time (min)	1	-55±3	30	2	25±2	3	3	125±3	30	4	25±2	3
			Step	Temperature (°C)	Time (min)													
1	-55±3	30																
2	25±2	3																
3	125±3	30																
4	25±2	3																
			Total: 100cycles Measured after exposure in the room condition for 24hrs															
1-2-2	Humidity Resistance		Temperature: 40±2°C Relative Humidity: 90 ~ 95% Time: 1000hrs Measured after exposure in the room condition for 24hrs															
1-2-3	High Temperature Resistance		Temperature: 125±3°C Relative Humidity: 20% Applied Current: Rated Current / Time: 1000hrs Measured after exposure in the room condition for 24hrs															
1-2-4	Low Temperature Resistance		Temperature: -55±3°C Relative Humidity: 0% / Time: 1000hrs Measured after exposure in the room condition for 24hrs															

CLH1005T Series Specification

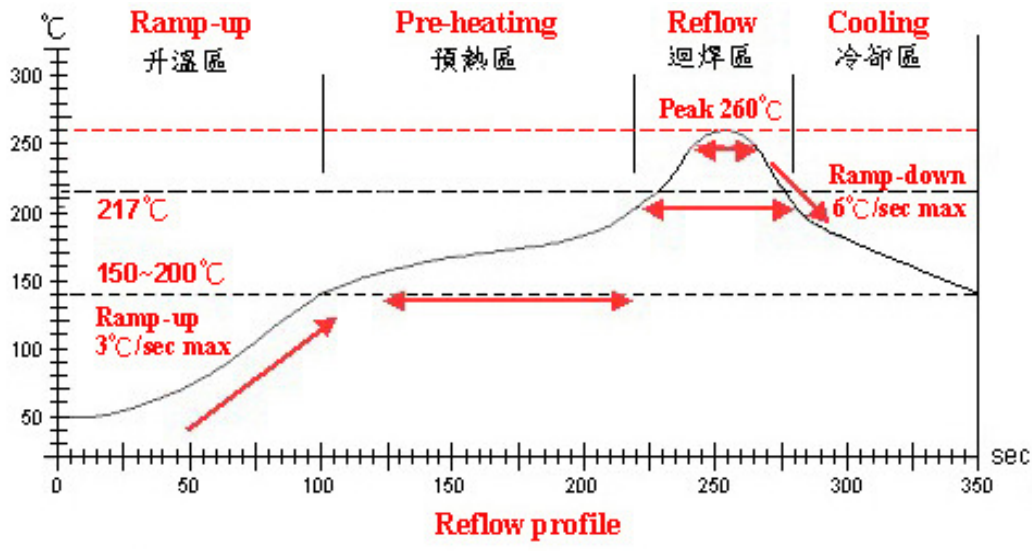

Lead-Free(LF) 標準溫度分析範圍

Refer to J-STD-020C

管制項目 Item.	升温區 Ramp-up	预热區 Pre-heating	迴焊區 Reflow	Peak Temp	冷却區 Cooling
溫度範圍 Temp.scope	R.T. ~ 150°C	150°C ~ 200°C	217°C	260±5°C	Peak Temp. ~ 150°C
標準時間 Time spec.	—	60 ~ 180 sec	60 ~ 150sec	20 ~ 40 sec	—
實際時間 Time result	—	75 ~ 100 sec	90 ~ 120sec	20 ~ 35 sec	—

NOTE :

1. Re-flow possible times : within 2 times
2. Nitrogen adopted is recommended while in re-flow



CLH1005T Series Specification

10 Test Data for Pre-production Samples

Chilisin P/N: CLH1005T-27NJ-H

Measured Item	L (nH)	Q Min.	SRF (MHz)Typ.	RDC (Ω)Max.	A m/m	B m/m	C m/m	D m/m			
Spec	Customer	27±5%									
	Suggest		8	2000	0.8	1.0±0.1	0.5±0.1	0.5±0.1	0.25±0.1		
Test Freq.	200mV 100MHz	200mV 100MHz									
1	26.9	11.8	2097	0.64	1.02	0.51	0.48	0.26			
2	26.1	12.2	2134	0.61	1.05	0.52	0.48	0.28			
3	27.5	12.1	2134	0.63	1.03	0.5	0.5	0.27			
4	28.2	11.6	2368	0.64	1.03	0.53	0.51	0.25			
5	27.1	12.4	2134	0.61	1.05	0.51	0.48	0.24			
6	27.2	12	2256	0.66	1.01	0.51	0.48	0.28			
7	26.1	12.1	2263	0.67	1.02	0.51	0.49	0.27			
8	27.3	11.5	2154	0.6	1.03	0.52	0.51	0.26			
9	28.1	11.3	2160	0.62	1.02	0.53	0.5	0.23			
10	27.3	11.1	2302	0.61	1.05	0.53	0.51	0.21			
11											
12											
13											
14											
15											
X	27.18	11.81	2200.2	0.629	1.031	0.517	0.494	0.255			
R	2.1	1.3	271	0.07	0.04	0.03	0.03	0.07			
Customer											
Sample											

Test Instrument
 Agilent E4991A+ Agilent 16197 FOR L,Q
 CHEN HWA 502BC / HP4338B FOR RDC
 Agilent E4991A+Agilent 16197&HP8753D FOR SRF

Appearance and Dimensions:
 SPEC : Refer to Item 6
 Test Method : Visual Inspection and Measured with Slide Calipers.

Test Conditions:

	Unless Otherwise Specified	In Case of Doubt
Temperature	Ordinary Temperature (15 to 35°C)	20 ± 2 °C
Humidity	Ordinary Humidity (25 to 85 %RH)	60 to 70 %RH

CLH1005T Series Specification

11 Packaging:

11.1 Packaging -Cover Tape

The force for tearing off cover tape is 10 to 100 grams in the arrow direction.

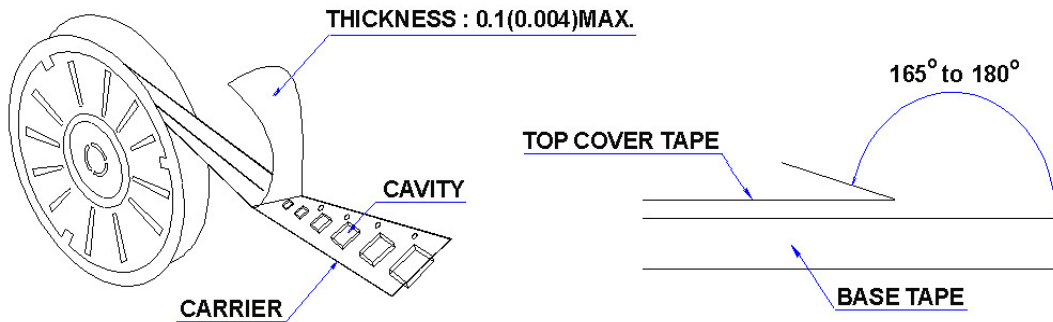

11.2 Packaging Quantity

TYPE	BULK	PCS/REEL
CLH1005	✓	10000

11.3 Reel Dimensions

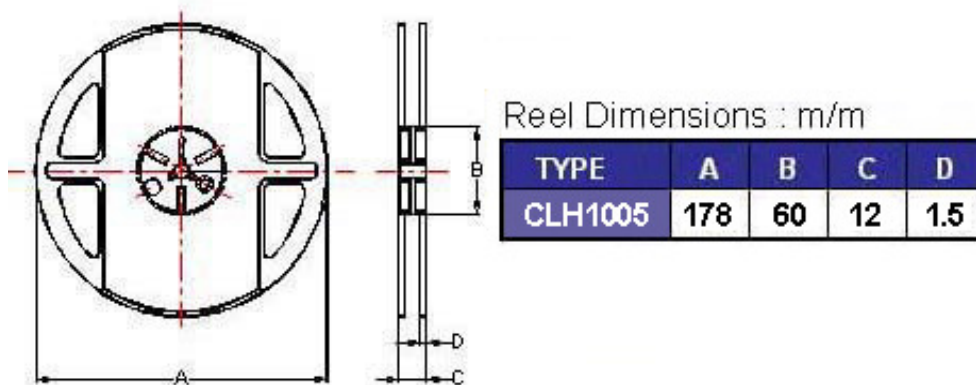

CLH1005T Series Specification

11 Packaging:

11.4 Tape Dimensions in mm

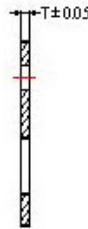
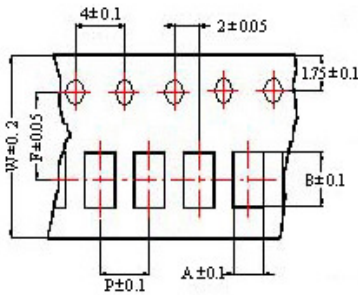

Tape Material

Carrier tape : Paper

Cover tape : Polyethylene

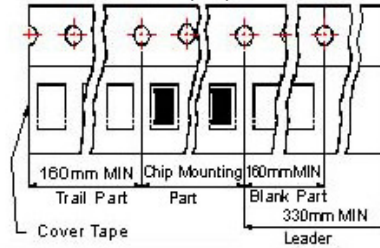

TYPE	A	B	T	W	P	F
CLH1005	0.65	1.15	0.60	8	2	3.5

12 Recommended Land Pattern:

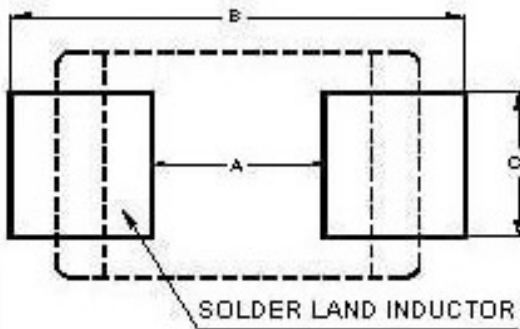

Dimensions in mm

TYPE	A	B	C
CLH1005	0.4	1.2 ~ 1.4	0.5

13 Note:

1. Please make sure that your product has been evaluated and confirmed against your specifications when our product is mounted to your product.
2. Do not knock nor drop.
3. All the items and parameters in this product specification have been prescribed on the premise that our product is used for the purpose, under the condition and in the environment agreed upon between you and us. You are requested not to use our product deviating from such agreement.
4. Please keep the distance between transformer/coil and other components (refer to the standard IEC 950)

CLH1005T Series Specification

14 Graph:

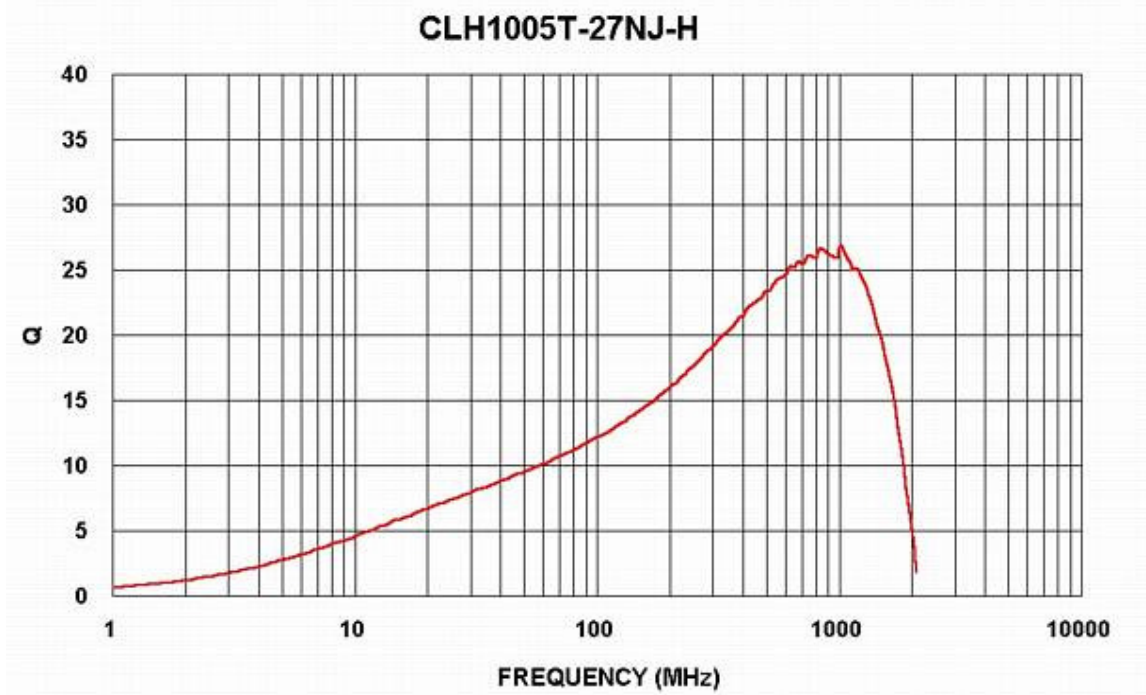
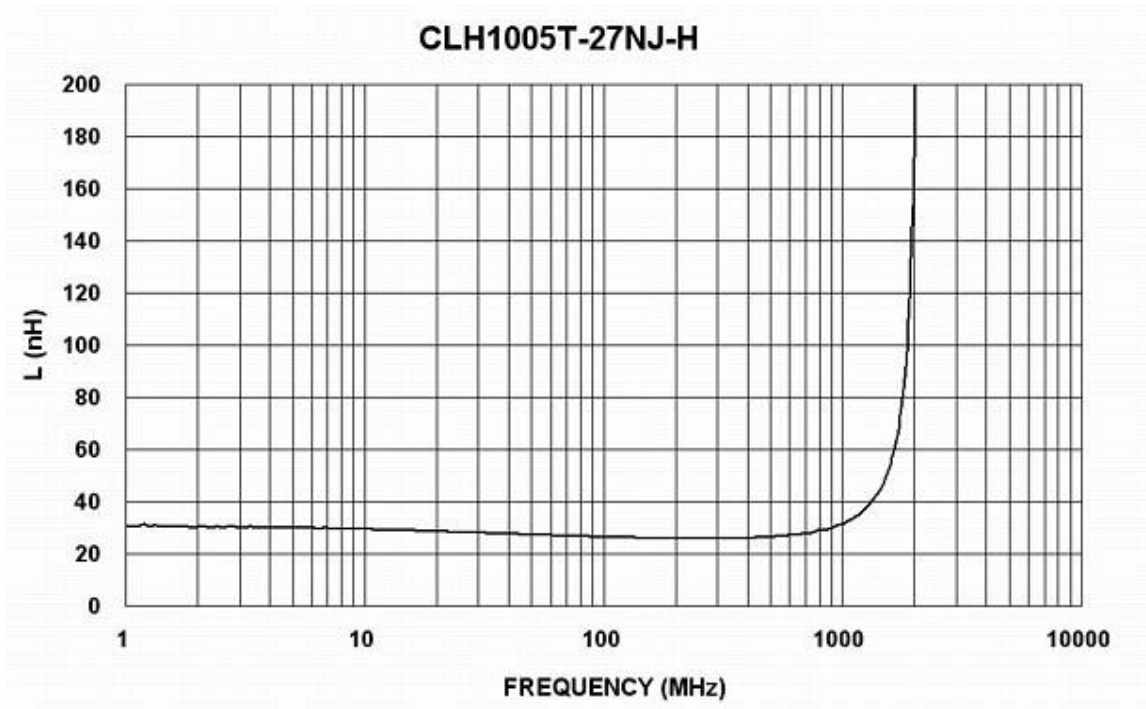

单击下面可查看定价，库存，交付和生命周期等信息

[>>CHILISIN\(奇力新\)](#)