



Application Note: SY7069

5.5V Maximum Output, 3A Valley Current, 1MHz Synchronous Boost with Auto Bypass Function

General Description

SY7069 is a high efficiency, synchronous, step-up boost converter designed for one-cell Li-Ion or Li-polymer, or a two to three-cell alkaline Ni-Cd or Ni-MH battery powered applications. It can convert down to 2.5V input voltage and up to 5.5V output voltage. It adopts NMOS for the main switch and PMOS for the synchronous switch.

SY7069 can disconnect the output from input during the shutdown mode. When input voltage exceeds the regulated output voltage, SY7069 enters bypass mode automatically.

Features

- 2.5V minimum input voltage
- Adjustable output voltage from 2.5V to 5.5V
- Min 3A valley current limit
- Capable for seamless transition between boost and bypass mode
- Load disconnect during shutdown
- Low $R_{DS(ON)}$ (main switch/synchronous switch) at 5.0V output: 50m Ω /90m Ω
- Output OVP protection
- Compact package TSOT23-6 package

Applications

- All Single Cell Li or Dual Cell Battery Operated Products as MP-3 Player, PDAs, and Other Portable Equipment.

Ordering Information

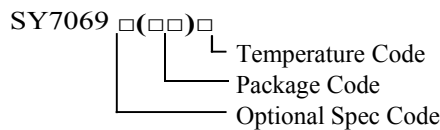

Ordering Number	Package type	Note
SY7069ADC	TSOT23-6	----

Typical Applications

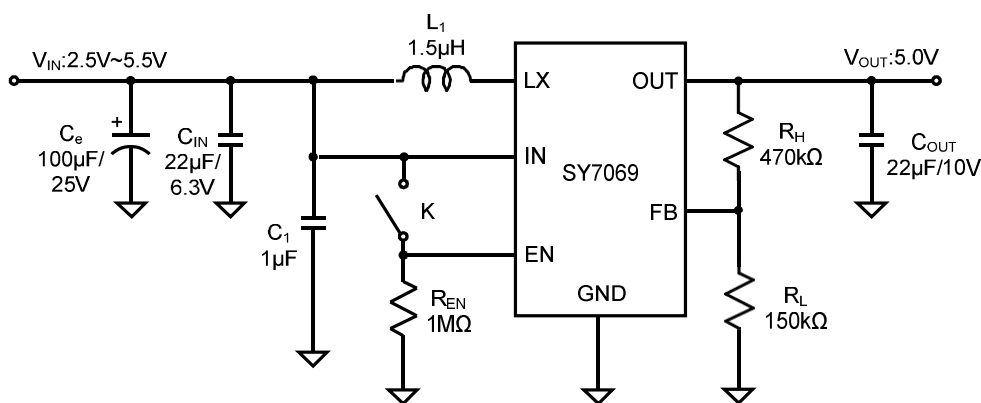
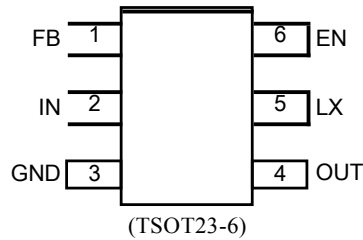

Figure 1. Schematic Diagram

Pinout (top view)



Top mark: **Iexyz** (Device code: Ie, x=year code, y=week code, z=lot number code)

Name	TSOT23-6	Description
FB	1	Output Feedback Pin. Connect this pin to the center point of the output resistor divider (as shown in Figure 1) to program the output voltage: $V_{OUT}=1.2 \times (1+R_H/R_L)$.
IN	2	Signal input pin. Decouple this pin to GND pin with at least 1uF ceramic cap for noise immunity consideration.
GND	3	Ground pin.
OUT	4	Output pin. Decouple this pin to GND pin with at least 22μF ceramic cap.
LX	5	Inductor node. Connect an inductor between IN pin and LX pin.
EN	6	Enable pin. Pull high to turn on. Do not leave it floating.

Absolute Maximum Ratings (Note 1)

All Pins	-----	6.0V
Power Dissipation, $P_D@ T_A=25^\circ\text{C}$, TSOT23-6	-----	1.92W
Package Thermal Resistance (Note 2)		
θ_{JA}	-----	52°C/W
θ_{JC}	-----	32°C/W
Junction Temperature Range	-----	150°C
Lead Temperature (Soldering, 10 sec.)	-----	260°C
Storage Temperature Range	-----	65°C to 150°C

Recommended Operating Conditions (Note 3)

IN	-----	2.5V to 5.5V
OUT	-----	2.5V to 5.5V
EN, FB	-----	V to $V_{OUT}+0.3V$
All other pins	-----	0-5.5V
Junction Temperature Range	-----	-40°C to 125°C
Ambient Temperature Range	-----	-40°C to 85°C

Electrical Characteristics

($V_{IN}=3.0V$, $V_{OUT}=5.0V$, $I_{OUT}=500mA$, $T_A=25^{\circ}C$ unless otherwise specified)

Parameter	Symbol	Test Conditions	Min	Typ	Max	Unit
Input Voltage	V_{IN}		2.5		5.5	V
Output Voltage Range	V_{OUT}		2.5		5.5	V
Quiescent Current	V_{IN}	$I_o=0A, V_{EN}=V_{IN}=3.0V, V_{OUT}=5.0V, V_{FB}=105\%V_{REF}$		8		μA
	V_{OUT}			32		
Shutdown Current	I_{SHDN}	$V_{EN}=0V, V_{IN}=3.0V$		0.1	1	μA
Linear Charge Current	I_{CHARGE}	$V_{OUT}<0.5V_{IN}$		1.5		A
Input Vin UVLO Threshold	V_{UVLO}				2.5	V
V_{IN} UVLO Hysteresis	V_{SYS}			0.1		V
EN Rising Threshold	V_{ENH}		1.2			V
EN Falling Threshold	V_{ENL}				0.4	V
Low Side Main FET R_{ON}	$R_{DS(ON)1}$	$V_{OUT}=5.0V$		50		$m\Omega$
Synchronous FET R_{ON}	$R_{DS(ON)2}$	$V_{OUT}=5.0V$		90		$m\Omega$
Synchronous FET Current Limit	I_{LIM}		3.0			A
Switching Frequency	F_{SW}			1.0		MHz
Feedback Reference Voltage	V_{REF}		1.182	1.2	1.218	V
Minimum on time	T_{ON_MIN}			80		ns
Minimum off time	T_{OFF_MIN}			80		ns
OUT pin OVP Protection				6.0		V
OUT pin OVP Hysteresis	OVP_{HYS}			0.25		V
Thermal Shutdown Temperature	T_{SD}			150		$^{\circ}C$
Thermal Shutdown Hysteresis	T_{HYS}			20		$^{\circ}C$

Note 1: Stresses beyond the “Absolute Maximum Ratings” may cause permanent damage to the device. These are stress ratings only. Functional operation of the device at these or any other conditions beyond those indicated in the operational sections of the specification is not implied. Exposure to absolute maximum rating conditions may affect device reliability.

Note 2: θ_{JA} is measured in the natural convection at $T_A=25^{\circ}C$ on a two-layer Silergy Evaluation Board.

Note 3: The device is not guaranteed to function outside its operating conditions.

Block Diagram

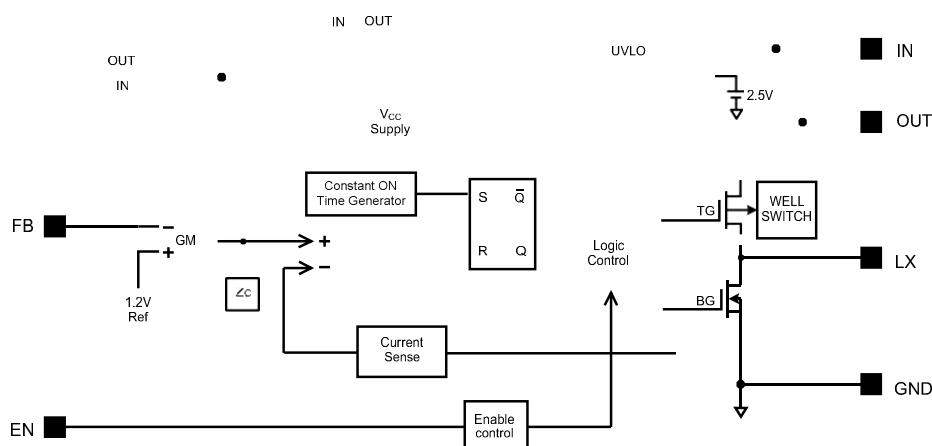

Typical Performance Characteristics

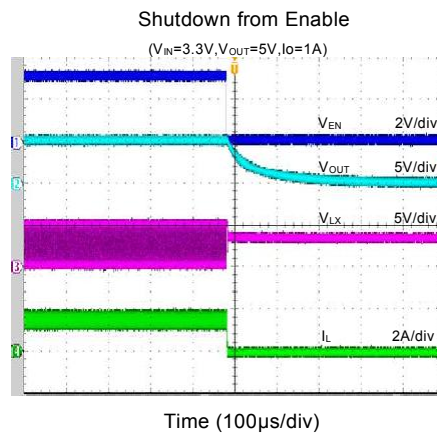
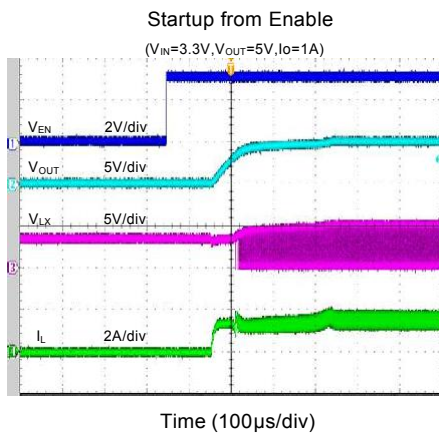
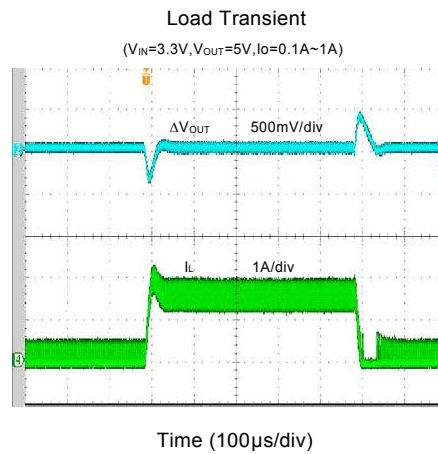
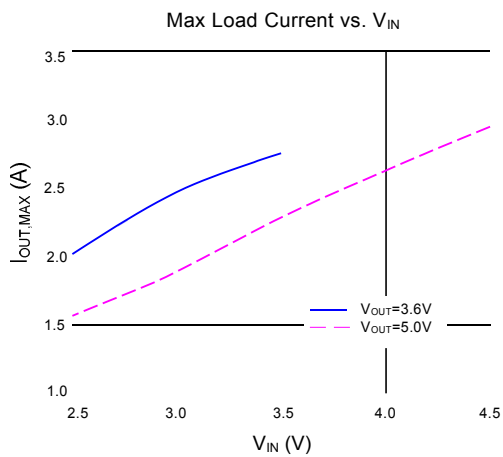
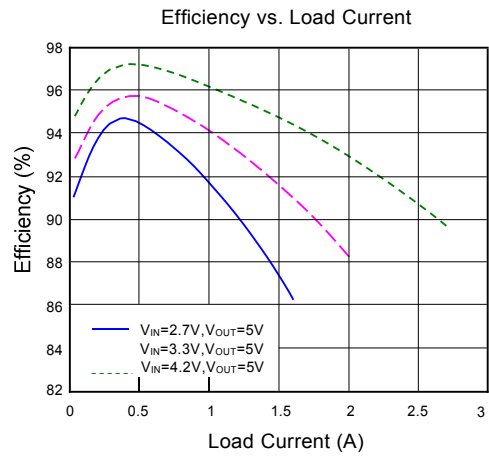
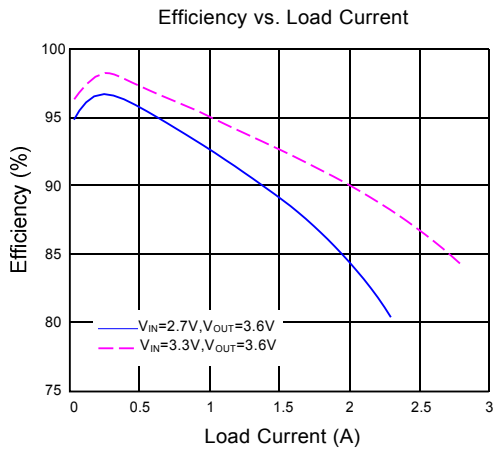

Short Circuit Protection
($V_{IN}=3.3V, V_{OUT}=5V, 0A$ to Short)

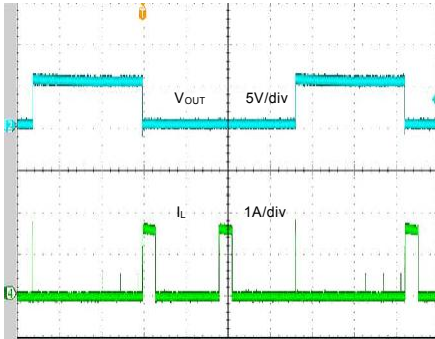

Time (20ms/div)

Short Circuit Protection
($V_{IN}=3.3V, V_{OUT}=5V, 1A$ to Short)

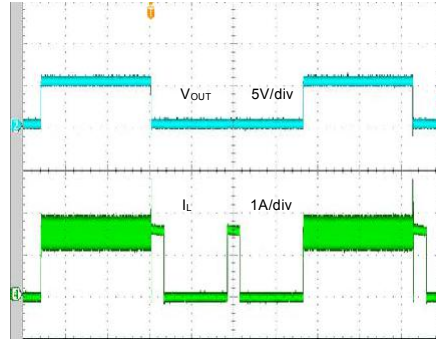

Time (20ms/div)

Seamless Transition: Boost Mode → Bypass Mode
($V_{IN}=3.3V-5.5V, V_{OUT}=5.0V, I_o=1.0A$)

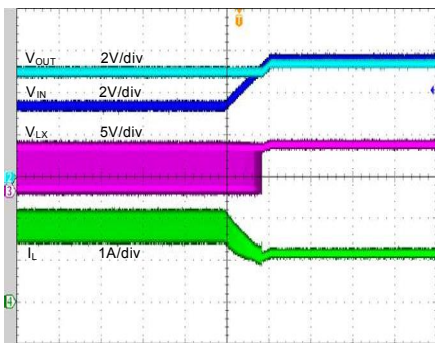

Time (10ms/div)

Seamless Transition: Bypass Mode → Boost Mode
($V_{IN}=5.5V-3.3V, V_{OUT}=5.0V, I_o=1.0A$)

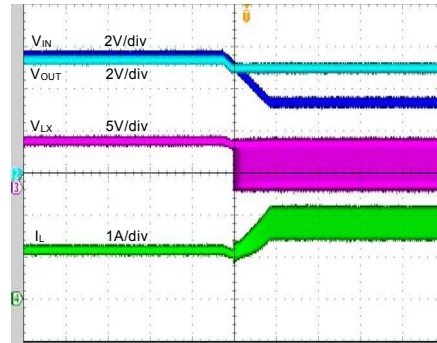

Time (10ms/div)

Output Ripple

($V_{IN}=3.3V, V_{OUT}=5V, I_o=1A$)

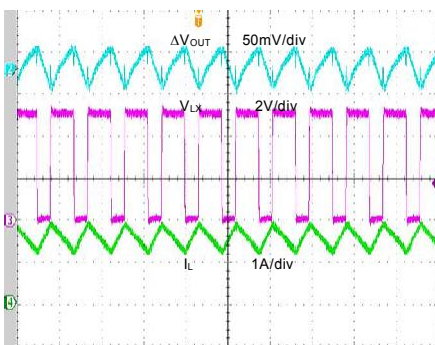

Time (1μs/div)

Applications Information

Because of the high integration for SY7069, only input capacitor C_{IN} , output capacitor C_{OUT} , inductor L and feedback resistors (R_H and R_L) need to be selected for the targeted applications specifications.

Feedback resistor dividers R_H and R_L :

Choose R_H and R_L to program the proper output voltage. To minimize the power consumption under light loads, it is desirable to choose large resistance values for both R_H and R_L . A value of between $10k\Omega$ and $1M\Omega$ is recommended for both resistors. If V_{OUT} is $5.0V$, $R_H=470k\Omega$ is chosen, using following equation, then R_L can be calculated to be $148.4k\Omega$:

$$R_L = \frac{1.2V}{V_{OUT} - 1.2V} R_H$$

$1.2V_{FB}$
 GND

V_{OUT}
 R_H
 R_L

Input capacitor C_{IN} :

The ripple current through input capacitor is calculated as:

$$I_{CIN_RMS} = \frac{V_{IN} \times (V_{OUT} - V_{IN})}{2.3 \times L \times F \times V_{SW} \times V_{OUT}}$$

To minimize the potential noise problem, place a typical X5R or better grade ceramic capacitor really close to the IN and GND pins. Care should be taken to minimize the loop area formed by C_{IN} , and

IN/GND pins. In this case, a $22\mu F$ low ESR ceramic capacitor is recommended.

Li-Ion battery hot plug consideration:

In the mass production stage, the Li-Ion Battery will always hot plug in between IC IN and GND pin. The hot plug may lead to large voltage spike and even lead to IC EOS fail. To avoid this potential risk, 1pcs $22\mu F$ ceramic cap serial with 0.1Ω resistor is recommended to absorb the input voltage spike.

With the recommended input absorb solution, the voltage spike can be reduced from $6.12V$ to $5.2V$.

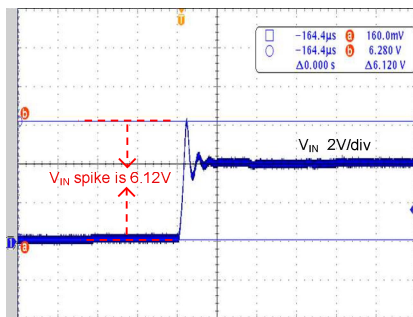
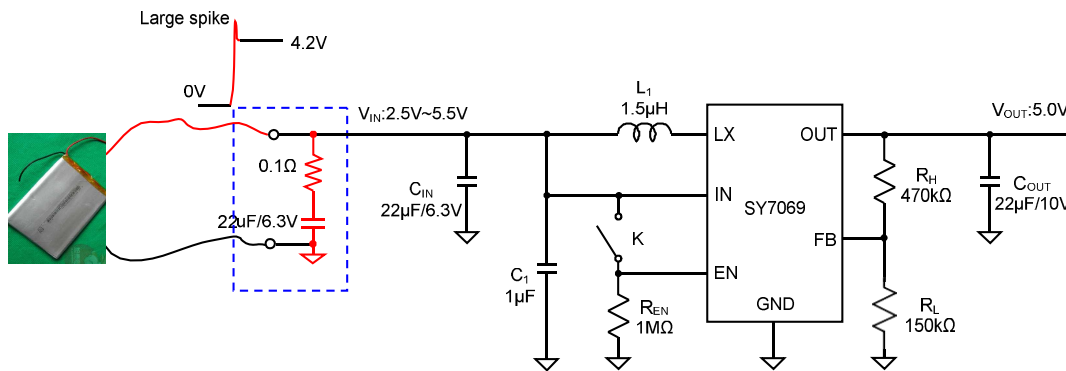

Time (40μs/div)
 $C_{IN}=22\mu F/6.3V$

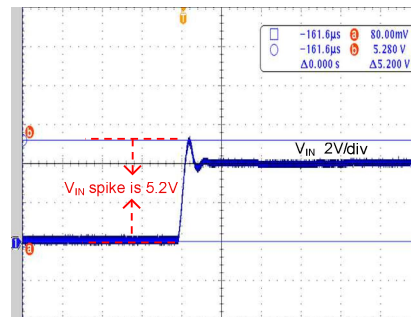

Time (40μs/div)
 $C_{IN}=22\mu F/6.3V/(22\mu F+0.1\Omega)$

Output capacitor C_{OUT}:

The output capacitor is selected to handle the output ripple noise requirements. Both steady state ripple and transient requirements must be taken into consideration when selecting this capacitor. For the best performance, it is recommended to use X5R or better grade ceramic capacitor with 10V rating and greater than 22μF capacitance.

Output inductor L:

There are several considerations in choosing this inductor.

- 1) Choose the inductance to provide the desired ripple current. It is suggested to choose the ripple current to be about 40% of the maximum output current. The inductance is calculated as:

$$L = \frac{(V_{IN})^2}{V_{OUT}} \frac{(V_{OUT} - V_{IN})}{F_{SW} \times I_{OUT,MAX} \times 40\%}$$

where F_{SW} is the switching frequency and $I_{OUT,MAX}$ is the maximum load current.

The SY7069 regulator IC is quite tolerant of different ripple current amplitude. Consequently, the final choice of inductance can be slightly off the calculation value without significantly impacting the performance.

- 2) The saturation current rating of the inductor must be selected to be greater than the peak inductor current under full load conditions.

$$I_{SAT,MIN} > \left(\frac{V_{OUT}}{V_{IN}} \right) \times I_{OUT,MAX} + \frac{V_{OUT} (V_{OUT} - V_{IN})}{V_{OUT} \times 2 \times F_{SW} \times L}$$

- 3) The DCR of the inductor and the core loss at the switching frequency must be low enough to achieve the desired efficiency requirement. It is

desirable to choose an inductor with $DCR < 50m\Omega$ to achieve a good overall efficiency.

Enable Operation

Pulling the EN pin low (<0.4V) will shut down the device. During shutdown mode, the SY7069 shutdown current drops to lower than 1μA. Driving the EN pin high (> 1.2V) will turn on the IC again.

Layout Design:

To achieve a higher efficiency and better noise immunity, following components should be placed close to the IC: C_{IN}, C_{OUT}, L, R_H and R_L.

- 1) It is desirable to maximize the PCB copper area connecting to GND pin to achieve the best thermal and noise performance. If the board space allowed, a ground plane is highly desirable. GND pin is recommended to connect to exposed paddle directly. Reasonable via holes are recommended to be placed under the exposed paddle for the better performance consideration.
- 2) For boost converter, the output current is discontinuous. So the loop area formed by C_{OUT}, OUT and GND must be minimized.
- 3) The decoupling capacitor of IN to GND C_{IN} must be placed as close as possible with IN pin.
- 4) The PCB copper area associated with LX pin must be minimized to improve the noise immunity.
- 5) The components R_H, R_L and the trace connecting to the FB pin must NOT be adjacent to the LX node on the PCB layout to minimize the noise coupling to FB pin.

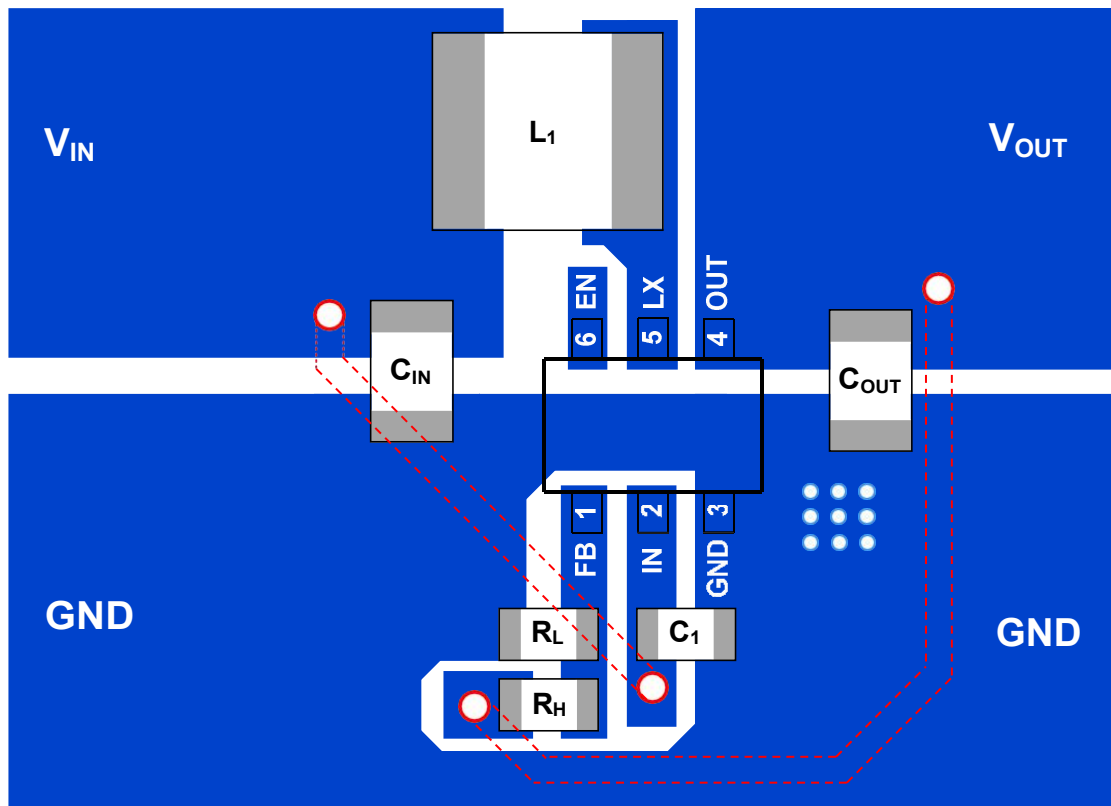

TSOT23-6 Package outline & PCB layout

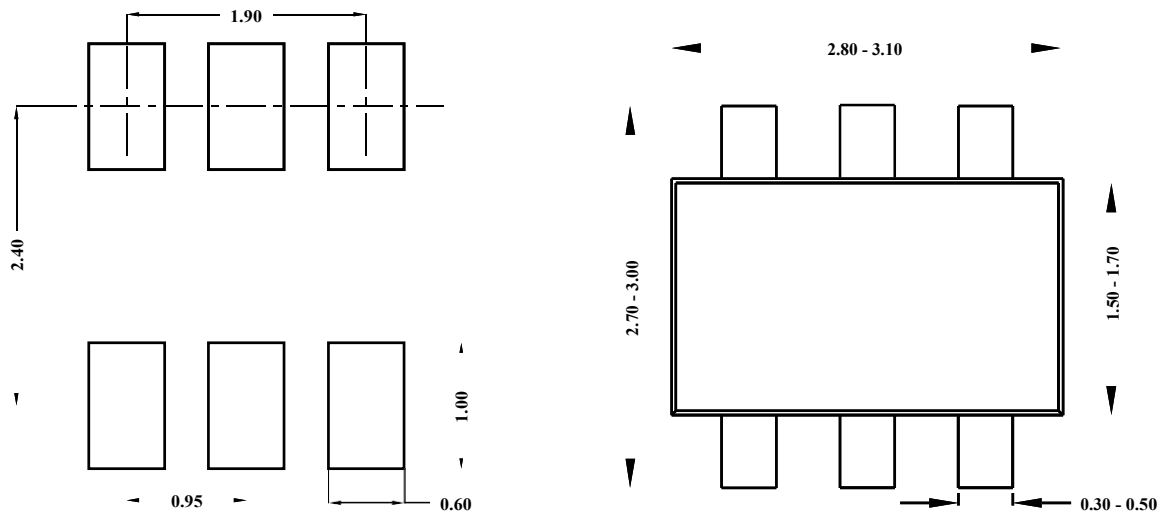

Recommended Pad Layout

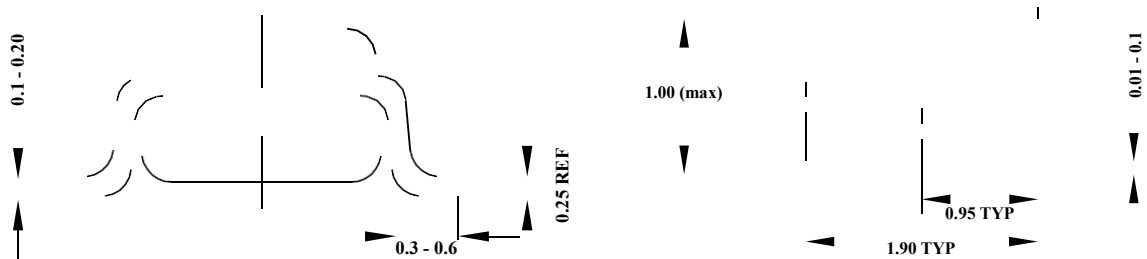

Notes: All dimensions are in millimeters
 All dimensions don't include mold flash & metal burr

Taping & Reel Specification

1. Taping orientation

TSOT23-6

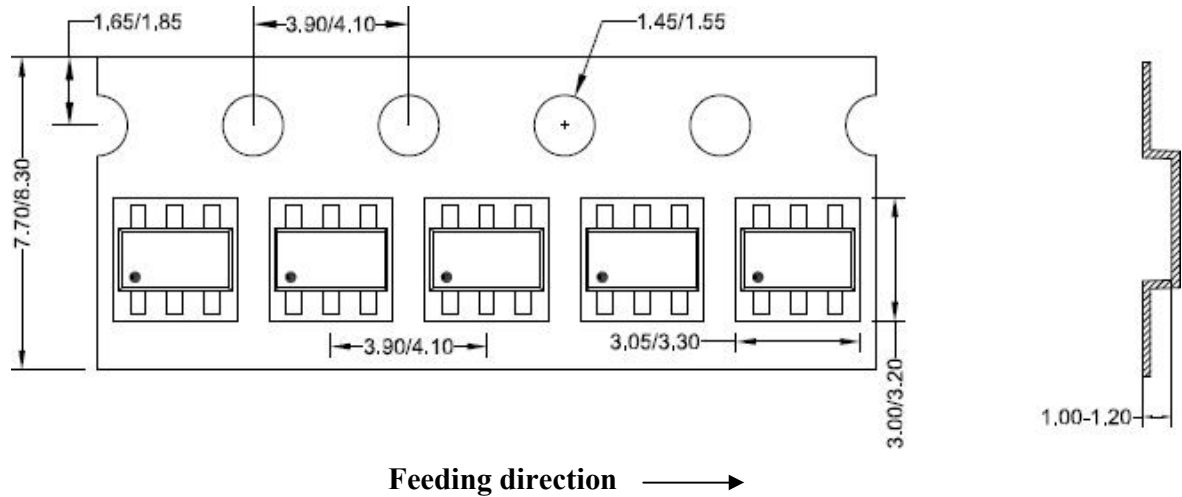

2. Carrier Tape & Reel specification for packages

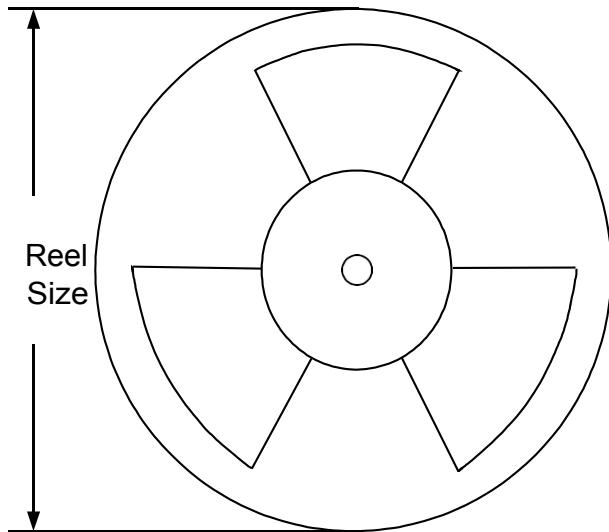

Package type	Tape width (mm)	Pocket pitch(mm)	Reel size (Inch)	Trailer length(mm)	Leader length (mm)	Qty per reel
TSOT23-6	8	4	7	400	160	3000

3. Others: NA

单击下面可查看定价，库存，交付和生命周期等信息

[>>SILERGY\(矽力杰\)](#)