



Product Summary

$V_{(BR)DSS}$	$R_{DS(on)TYP}$	I_D
-40V	31mΩ@-10V	-7A
	39mΩ@-4.5V	
40V	16mΩ@10V	9A
	27mΩ@4.5V	

Feature

- Low drain-source ON-resistance
- High forward transfer admittance
- Low leakage current

Application

- Low voltage applications

MARKING:

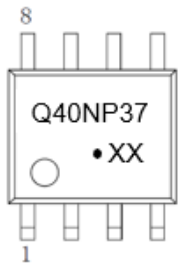

Q40NP37 = Device Code

XX = Date Code

Solid dot = Green Device

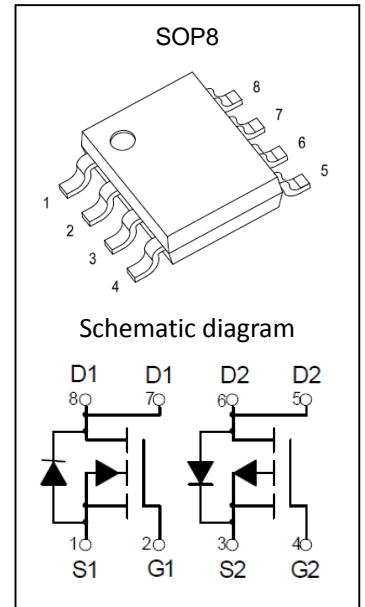

ABSOLUTE MAXIMUM RATINGS ($T_a=25^{\circ}C$ unless otherwise noted)

Parameter	Symbol	Value	Unit
P-MOSFET			
Drain-Source Voltage	V_{DS}	-40	V
Gate-Source Voltage	V_{GS}	±20	V
Continuous Drain Current ⁽¹⁾	I_D	-7	A
Pulsed Drain Current	I_{DM}	-21	A
Power Dissipation	P_D	1.4	W
N-MOSFET			
Drain-Source Voltage	V_{DS}	40	V
Gate-Source Voltage	V_{GS}	±20	V
Continuous Drain Current	I_D	9	A
Pulsed Drain Current ⁽¹⁾	I_{DM}	27	A
Power Dissipation	P_D	1.4	W
Temperature and Thermal Resistance			
Thermal Resistance from Junction to Ambient ⁽²⁾	$R_{\theta JA}$	89	°C/W
Junction Temperature	T_J	150	°C
Storage Temperature	T_{STG}	-55~ +150	°C

P-channel MOSFET ELECTRICAL CHARACTERISTICS ($T_a=25^\circ\text{C}$ unless otherwise noted)

Parameter	Symbol	Test Condition	Min	Type	Max	Unit
Static Characteristics						
Drain-source breakdown voltage	$V_{(BR)DSS}$	$V_{GS} = 0V, I_D = -250\mu A$	-40			V
Zero gate voltage drain current	I_{DSS}	$V_{DS} = -32V, V_{GS} = 0V$			-1	μA
Gate-body leakage current	I_{GSS}	$V_{GS} = \pm 20V, V_{DS} = 0V$			± 100	nA
Gate threshold voltage	$V_{GS(th)}$	$V_{DS} = V_{GS}, I_D = -250\mu A$	-1.5	-2.1	-3.0	V
Drain-source on-resistance ⁽³⁾	$R_{DS(on)}$	$V_{GS} = -10V, I_D = -5.0A$		31	37	m Ω
		$V_{GS} = -4.5V, I_D = -5.0A$		39	47	
Forward transconductance	g_{FS}	$V_{DS} = -5V, I_D = -5.0A$	5			S
Diode forward voltage ⁽³⁾	V_{DS}	$I_S = -1.0A, V_{GS} = 0V$			-1.2	V
Dynamic characteristics⁽⁴⁾						
Input Capacitance	C_{iss}	$V_{DS} = -20V, V_{GS} = 0V, F = 1.0MHz$		850		pF
Output Capacitance	C_{oss}			101		
Reverse Transfer Capacitance	C_{rss}			65		
Total gate charge	Q_g	$V_{DS} = -20V, I_D = -5A, V_{GS} = -4.5V$		9.5		nC
Gate-source charge	Q_{gs}			2		
Gate-drain charge	Q_{gd}			3		
Switching Characteristics⁽⁴⁾						
Turn-on delay time	$t_{d(on)}$	$V_{DD} = -20V, I_D = -5A$ $V_{GS} = -10V, R_{GEN} = 6\Omega$		7		nS
Turn-on rise time	t_r			3		
Turn-off delay time	$t_{d(off)}$			20		
Turn-off fall time	t_f			12		

N-channel MOSFET ELECTRICAL CHARACTERISTICS ($T_a=25^\circ\text{C}$ unless otherwise noted)

Parameter	Symbol	Test Condition	Min	Type	Max	Unit
Static Characteristics						
Drain-source breakdown voltage	$V_{(BR)DSS}$	$V_{GS} = 0V, I_D = 250\mu A$	40			V
Zero gate voltage drain current	I_{DSS}	$V_{DS} = 32V, V_{GS} = 0V$			1	μA
Gate-body leakage current	I_{GSS}	$V_{GS} = \pm 20V, V_{DS} = 0V$			± 100	nA
Gate threshold voltage	$V_{GS(th)}$	$V_{DS} = V_{GS}, I_D = 250\mu A$	1.5	1.8	3.0	V
Drain-source on-resistance ⁽³⁾	$R_{DS(on)}$	$V_{GS} = 10V, I_D = 6.0A$		16	21	m Ω
		$V_{GS} = 4.5V, I_D = 6.0A$		27	32	
Forward transconductance	g_{FS}	$V_{DS} = 5V, I_D = 6.0A$	10			S
Diode Forward voltage ⁽³⁾	V_{DS}	$I_S = 1.0A, V_{GS} = 0V$			1.2	V
Dynamic characteristics⁽⁴⁾						
Input Capacitance	C_{iss}	$V_{DS} = 20V, V_{GS} = 0V, F = 1.0MHz$		633		pF
Output Capacitance	C_{oss}			65		
Reverse Transfer Capacitance	C_{rss}			55		
Total gate charge	Q_g	$V_{DS} = 20V, I_D = 6.0A, V_{GS} = 4.5V$		9.5		nC
Gate-source charge	Q_{gs}			1.5		
Gate-drain charge	Q_{gd}			3		
Switching Characteristics⁽⁴⁾						
Turn-on delay time	$t_{d(on)}$	$V_{DD} = 20V, R_L = 2.7\Omega$		3.3		ns
Turn-on rise time	t_r			4.8		
Turn-off delay time	$t_{d(off)}$	$V_{GS} = 10V, R_{GEN} = 3\Omega$		26		
Turn-off fall time	t_f			4		

Notes:

1. Repetitive Rating : Pulse width limited by maximum junction temperature.
2. Surface Mounted on FR4 Board, $t < 5$ sec.
3. Pulse Test : Pulse Width $\leq 300\mu s$, Duty Cycle $\leq 2\%$.
4. Guaranteed by design, not subject to production testing.

Typical Electrical and Thermal Characteristics

P-Channel MOS

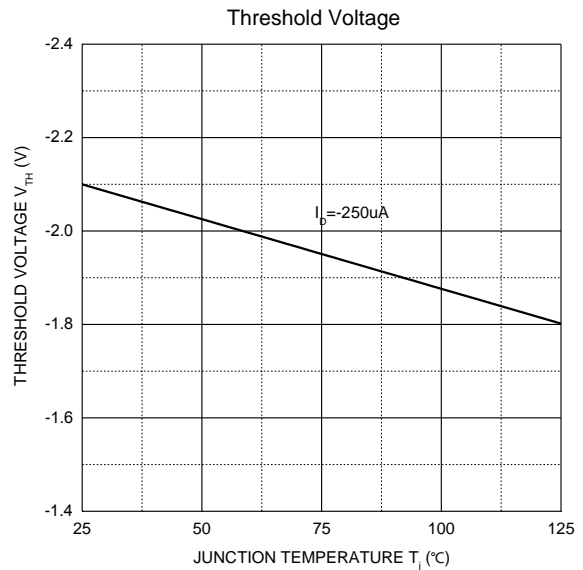
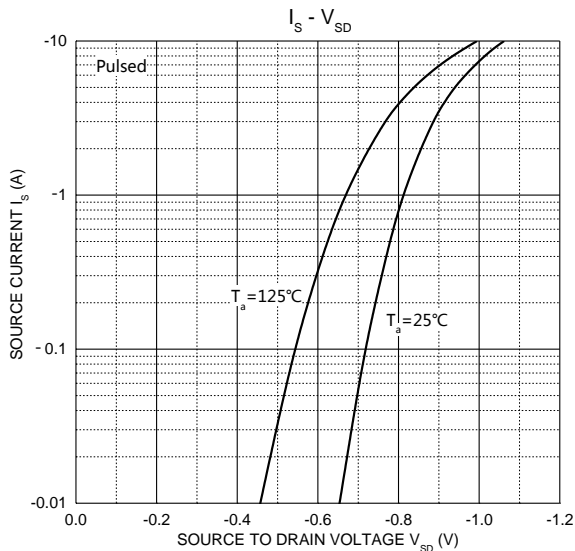
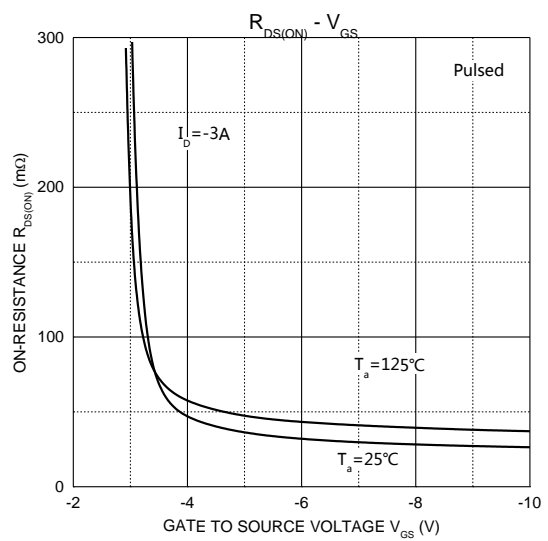
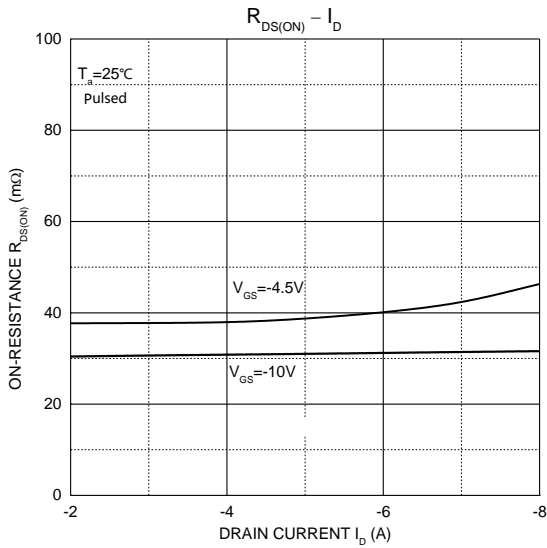
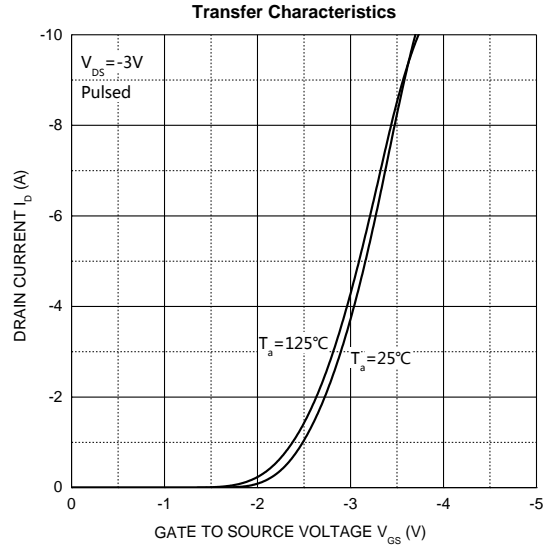
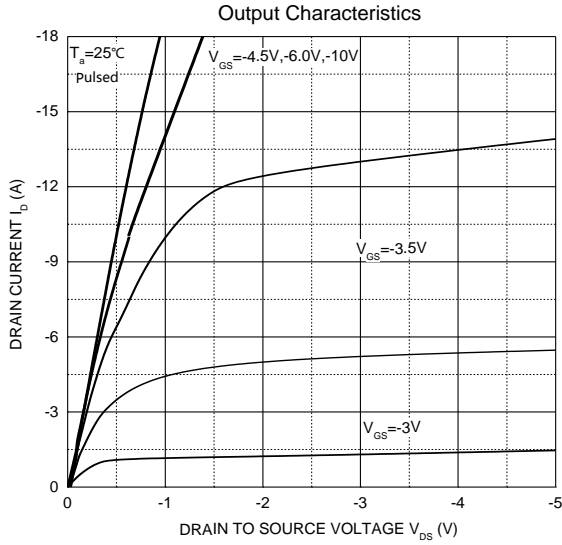

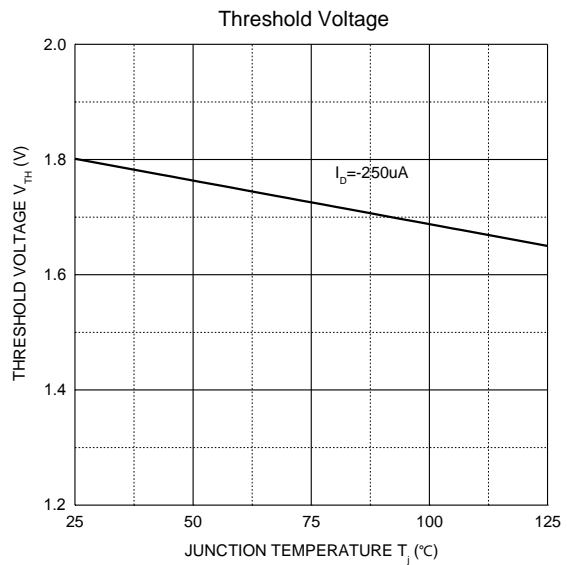
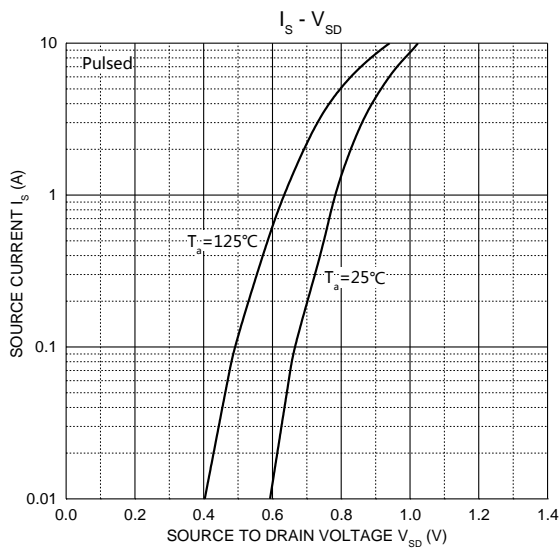
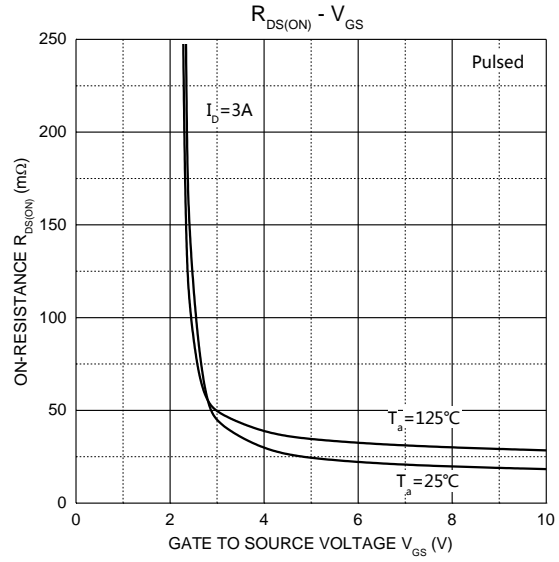
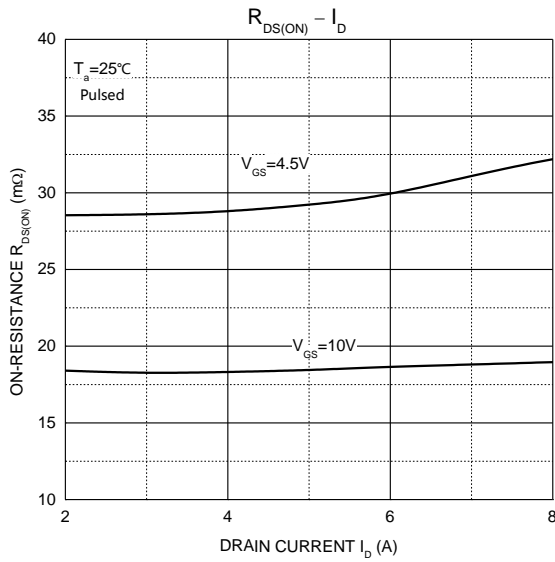
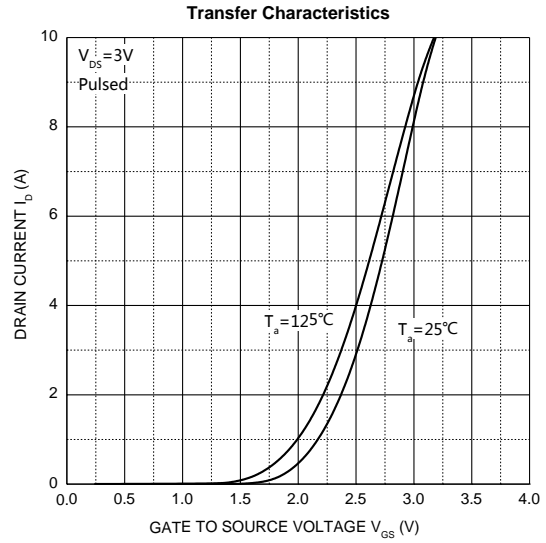
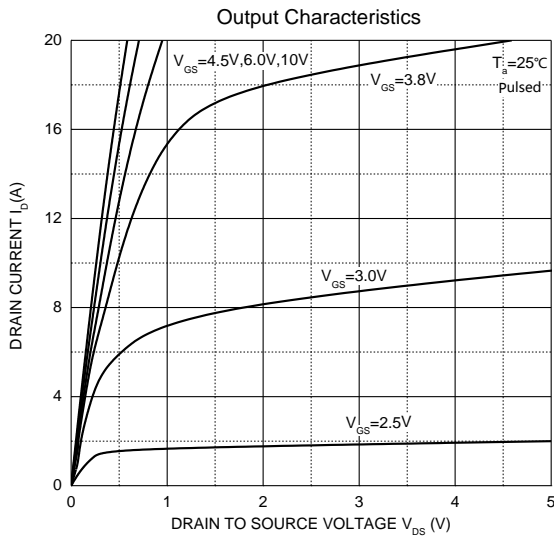

SOP8 Package Information

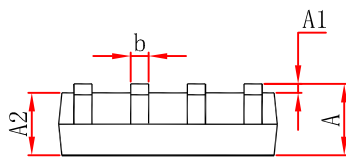
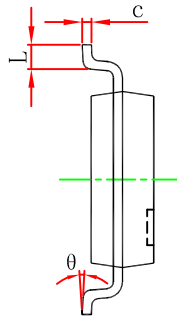
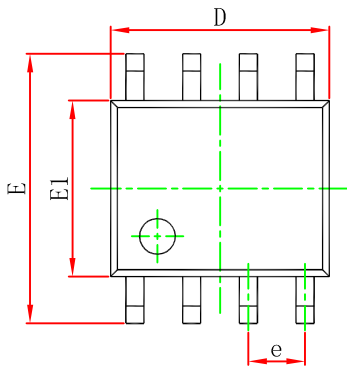

Symbol	Dimensions In Millimeters		Dimensions In Inches	
	Min	Max	Min	Max
A	1.350	1.750	0.053	0.069
A1	0.100	0.250	0.004	0.010
A2	1.350	1.550	0.053	0.061
b	0.330	0.510	0.013	0.020
c	0.170	0.250	0.007	0.010
D	4.800	5.000	0.189	0.197
e	1.270 (BSC)		0.050 (BSC)	
E	5.800	6.200	0.228	0.244
E1	3.800	4.000	0.150	0.157
L	0.400	1.270	0.016	0.050
θ	0°	8°	0°	8°

SOP8 Tape and Reel

SOP8 Embossed Carrier Tape

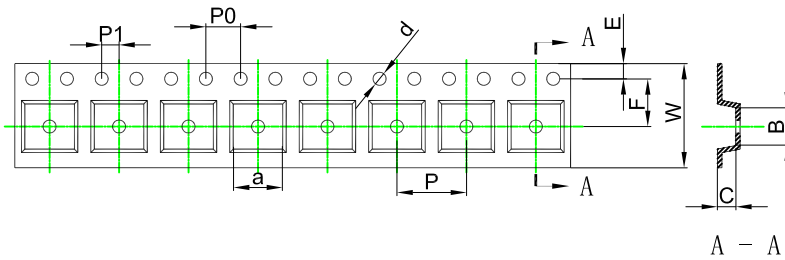

Dimensions are in millimeter										
Pkg type	a	B	C	d	E	F	P0	P	P1	W
SOP8	6.40	5.40	2.10	Ø1.50	1.75	5.50	4.00	8.00	2.00	12.00

SOP8 Tape Leader and Trailer

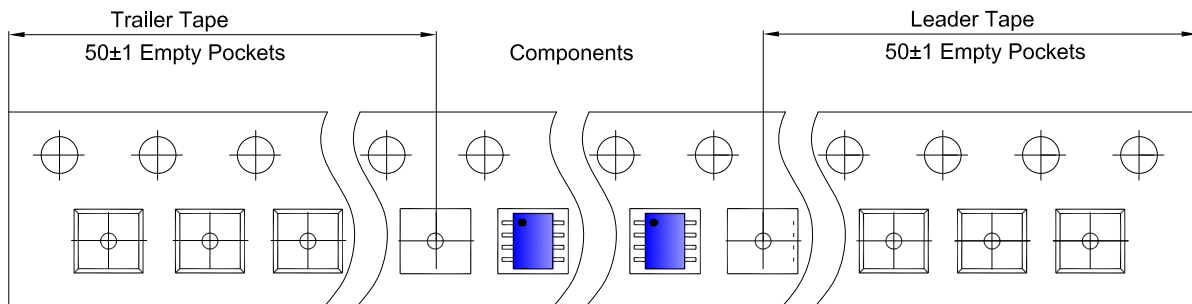

SOP8 Reel

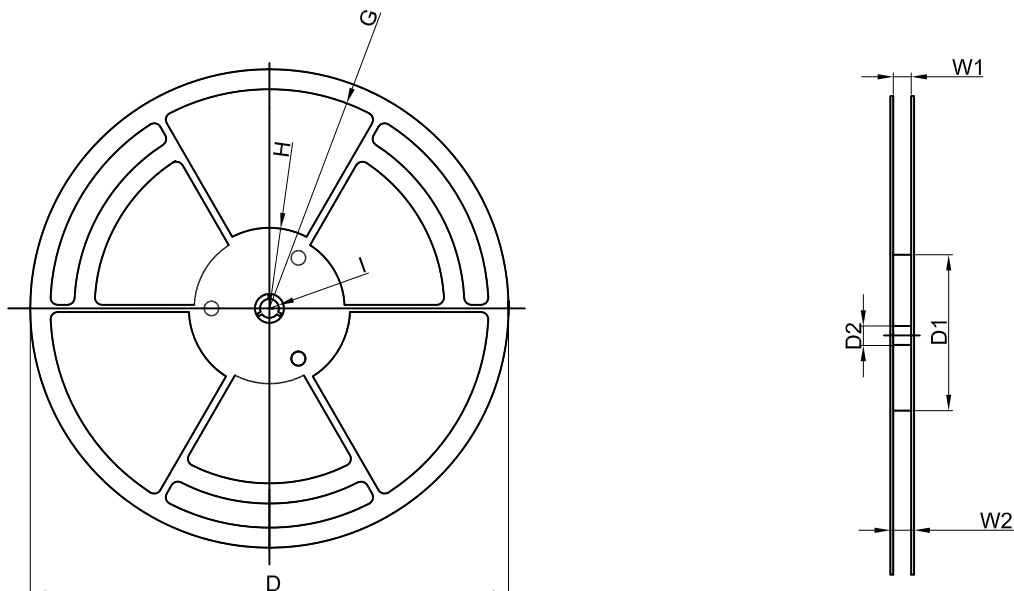

Dimensions are in millimeter								
Reel Option	D	D1	D2	G	H	I	W1	W2
13" Dia	Ø330.00	100.00	13.00	R151.00	R56.00	R6.50	12.40	17.60

REEL	Reel Size	Box	Box Size(mm)	Carton	Carton Size(mm)	G.W.(kg)
4,000 pcs	13 inch	8,000 pcs	360×360×65	64,000 pcs	565×380×390	

单击下面可查看定价，库存，交付和生命周期等信息

[>>GP\(格瑞宝\)](#)