



## 一、概述

### 产品特性概述

- 1、此类电容器为汽车专用电子元器件，已通过 AEC-Q200 标准设定的所有实验条件，在汽车使用过程中更具稳定性、安全性。
- 2、材料使用主要有温度稳定性能较高的 COG 以及高介电常数的 X7R、X7S。
- 3、产品适用于汽车引擎与驱动的传感模块、以及车载电子终端设备。

## SUMMARY

### Summary of Automotive Capacitor characteristics

- 1 This kind of capacitor special electronic components for cars. Has passed the AEC - Q200 standards set all of the experimental conditions. In the process of automobile application more stability and security.
- 2 Materials used are high temperature stability of COG and the high dielectric constant X7R X7S.
- 3 Product is suitable for the sensing module on the automobile engines and drive, and the vehicle electronic terminal equipment.



## 二、型号规格表示方法 HOW TO ORDER

AM    05    CG    101    J    500    N    T

### 说明 NOTES :

AM : Automotive Mlcc 汽车电子产品

### 尺寸 DIMENSIONS

单位 (unit) : inch/ mm

尺寸规格 Size Code	01	02	03	05	06	10	08	12
长×宽 (L×W) inch	0.02×0.01	0.04×0.02	0.06×0.03	0.08×0.05	0.12×0.06	0.12×0.10	0.18×0.08	0.18×0.12
长×宽 (L×W) mm	0.60×0.30	1.00×0.50	1.60×0.80	2.00×1.25	3.20×1.60	3.20×2.50	4.50×2.00	4.50×3.20

### 介质种类 DIELECTRIC STYLE

介质种类 (Dielectric Code)	CG	B	BS
介质材料 (Dielectric)	COG	X7R	X7S

### 标称容量 NOMINAL CAPACITANCE

单位(unit) : pF

表示方式 (Express Method)	实际值 (Actual Value)	注 :头两位数字为有效数字 ,第三位数字为 0 的个数 ; R 为小数点。 Note: the first two digits are significant; third digit denotes number of zeros; R=decimal point.
0R5	0.5	
1R0	1.0	
102	$10 \times 10^2$	
224	$22 \times 10^4$	
...	...	

### 容量误差 CAPACITANCE TOLERANCE

代码 (Code)	A	B	C	D	F	G	J	K	M
误差 (Tolerance)	±	±	±	±	±	±	±	±10%	±20%
	0.05pF	0.10pF	0.25pF	0.5pF	1.0%	2.0%	5.0%		

备注 : A、B、C、D 级误差适用于容量 10pF 的产品。

Note : These capacitance tolerance A , B, C, D are just applicable the capacitance that equals to or less than 10pF.



额定电压 RATED VOLTAGE

单位(unit) : V

表示方式 (Express Method)	实际值 (Actual Value)	注：头两位数字为有效数字，第三位数字为 0 的个数；R 为小数点。 Note: the first two digits are significant; third digit denotes number of zeros; R=decimal point.
6R3	6.3	
500	$50 \times 10^0$	
201	$20 \times 10^1$	
102	$10 \times 10^2$	
...	...	

端头材料 TERMINAL MATERIAL STYLES

端头类别 ( Termination Styles )	表示方式 (Express Method)	产品规格 Product specification
柔性端头 ( The flexible Termination )	A	AM03 及以上尺寸的 X7R/X7S 产品 AM03 X7R/X7S and above size products
三层电镀端头 ( Nickel Barrier Termination )	N	所有 COG 产品、所有 AM01 与 AM02 规格 All COG products, all AM01 and AM02 specifications

包装方式 PACKAGE STYLES

B	T
散包装 ( Bulk Bag )	编带包装 ( Taping Package )

三、温度系数/特性 Temperature Coefficient /Characteristics

介质种类 Dielectric	参考温度点 Reference Temperature Point	标称温度系数 Temperature Coefficient	工作温度范围 Operation Temperature Range
COG	20°C	0±30 ppm/	-55 ~ 125
X7R	20°C	±15%	-55 ~ 125
X7S	20°C	±20%	-55 ~ 125

备注： 类电容器标称温度系数和允许偏差是采用温度在 20°C 和 85°C 之间的电容量变化来确定的，而 类电容器标称温度系数是按照工作范围之间的电容量相对 20°C 的电容量变化来确定的。

Note : Nominal temperature coefficient and allowed tolerance of class are decided by the changing of the capacitance between 20°C and 85°C. Nominal temperature coefficient of class are decided by the temperature of 20°C.



#### 四、尺寸及结构 DIMENSIONS AND STRUCTURE

##### 尺寸 DIMENSIONS

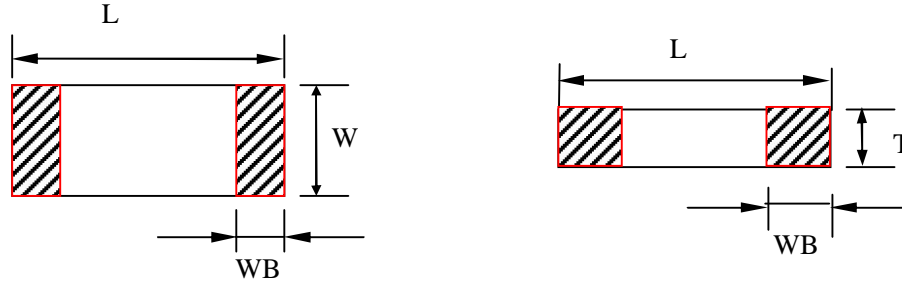

型号 Type		尺寸 Dimensions (mm)			
英制表示 British expression	公制表示 Metric expression	L	W	T	WB
0201	0603	$0.6 \pm 0.03$	$0.3 \pm 0.03$	$0.3 \pm 0.03$	$0.15 \pm 0.10$
0402	1005	$1.00 \pm 0.05$	$0.50 \pm 0.05$	$0.50 \pm 0.05$	$0.25 \pm 0.10$
0603	1608	$1.60 \pm 0.10$	$0.80 \pm 0.10$	$0.80 \pm 0.10$	$0.30 \pm 0.10$
0805	2012	$2.00 \pm 0.20$	$1.25 \pm 0.20$	$0.80 \pm 0.20$ $1.25 \pm 0.20$	$0.50 \pm 0.20$
1206	3216	$3.20 \pm 0.30$	$1.60 \pm 0.30$	$0.80 \pm 0.20$ $1.25 \pm 0.20$ $1.60 \pm 0.30$	$0.60 \pm 0.30$
1210	3225	$3.20 \pm 0.30$	$2.50 \pm 0.30$	2.80	$0.60 \pm 0.30$
1808	4520	$4.50 \pm 0.40$	$2.00 \pm 0.20$	2.20	$0.60 \pm 0.30$
1812	4532	$4.50 \pm 0.40$	$3.20 \pm 0.30$	3.50	$0.60 \pm 0.30$

备注：可根据客户的特殊要求设计符合客户需求的产品。

Note : We can design according to customer special requirements.

##### 结构 STRUCTURE

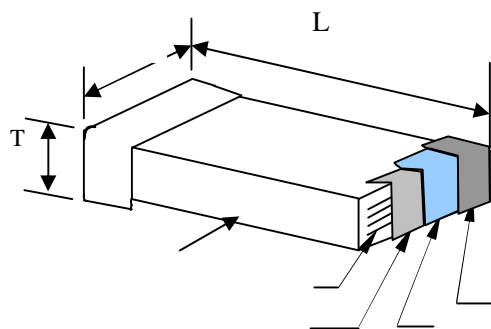

序号 NO	名称 Name
	陶瓷介质 Ceramic dielectric
	内电极 Inner electrode
	外电极 Substrate electrode
	镍层 Nickel Layer
	锡层 Tin Layer



## 五、容量范围及其电压 Capacitance Range and Operating Voltage

COG容量范围 Capacitance Range For COG

单位/unit : pF

温度特性		COG(NPO)		
型号规格	尺寸规格 Size Code	额定电压 Rated Voltage	容量范围 ( pf ) Capacitance	厚度标准 Thickness
AM01	0201	25V	0.1 ~ 100	0.3 ± 0.03
		50V	0.1 ~ 100	0.3 ± 0.03
AM02	0402	25V	0.1 ~ 220	0.5 ± 0.05
		50V	0.1 ~ 220	0.5 ± 0.05
AM03	0603	50V	0.1~1,000	0.8 ± 0.10
		100V	0.1~820	0.8 ± 0.10
		250V	0.1~470	0.8 ± 0.10
AM05	0805	50V	0.1~4,700	0.8 ± 0.20
		100V	0.1~1,000	0.8 ± 0.20
		250V	0.1~470	0.8 ± 0.20
AM06	1206	50V	10~10,000	0.8 ± 0.20
		100V	10~2,700	0.8 ± 0.20
		250V	10~2,700	0.8 ± 0.20
		500V	10~1,500	0.8 ± 0.20
		630V	10~1,000	1.25 ± 0.20
AM10	1210	50V	1.0~10,000	1.25 ± 0.20
		100V	1.0~4,700	1.25 ± 0.20
		250V	1.0~3,300	1.25 ± 0.20
		500V	1.0 ~ 2,000	1.25 ± 0.20
		630V	1.0 ~ 2,000	1.25 ± 0.20
AM08	1808	25V	10 ~ 10,000	2.20
		50V	10 ~ 6,800	2.20
		100V	2.0 ~ 4,700	2.20
		250V	2.0 ~ 3,300	2.20
		500V	2.0 ~ 1,800	2.20
		630V	2.0 ~ 1,800	2.20



COG容量范围 Capacitance Range For COG

单位/unit : pF

温度特性		COG(NPO)		
型号规格	尺寸规格 Size Code	额定电压 Rated Voltage	容量范围 ( pf ) Capacitance	厚度标准 Thickness
AM12	1812	25V	10 ~ 15,000	3.50
		50V	10 ~ 12,000	3.50
		100V	10~10,000	3.50
		250V	3.0 ~ 5,600	3.50
		500V	3.0 ~ 3,900	3.50
		630V	3.0 ~ 3,900	3.50

X7R与 X7S容量范围 Capacitance Range For X7R & X7S

单位/unit : pF

温度特性			X7R	X7S	
型号规格	尺寸规格 Size Code	额定电压 Rated Voltage	容量范围(PF) Capacitance	容量范围(PF) Capacitance	厚度标准 Thickness
AM01	0201	6.3V	—	—	0.3 ± 0.03
		10V	100 ~ 10,000	—	0.3 ± 0.03
		16V	100 ~ 3,300	—	0.3 ± 0.03
		25V	100 ~ 1,500	—	0.3 ± 0.03
AM02	0402	10V	220~100,000	10,000~100,000	0.5 ± 0.05
		16V	220~100,000	10,000~100,000	0.5 ± 0.05
		25V	220~47,000	4,700~47,000	0.5 ± 0.05
		50V	220~10,000	4,700~10,000	0.5 ± 0.05
AM03	0603	10V	1,000~220,000	10,000~220,000	0.8 ± 0.10
		16V	1,000~220,000	10,000~220,000	0.8 ± 0.10
		25V	1,000~220,000	10,000~220,000	0.8 ± 0.10
		50V	1,000~220,000	10,000~220,000	0.8 ± 0.10
		100V	1,000~47,000	—	0.8 ± 0.10



X7R与 X7S容量范围 Capacitance Range For X7R & X7S

单位/unit : pF

温度特性			X7R	X7S			
型号规格	尺寸规格 Size Code	额定电压 Rated Voltage	容量范围(PF) Capacitance	容量范围(PF) Capacitance	厚度标准 Thickness		
AM05	0805	10V	1,000~100,000	1,000~100,000	0.8 ± 0.20		
			150,000~1,000,000	150,000~1,000,000	1.25 ± 0.20		
		16V	1,000~100,000	1,000~100,000	0.8 ± 0.20		
			150,000~1,000,000	150,000~1,000,000	1.25 ± 0.20		
		25V	1,000~100,000	1,000~100,000	0.8 ± 0.20		
			150,000~1,000,000	150,000~1,000,000	1.25 ± 0.20		
		50V	1,000~150,000	1,000~150,000	0.8 ± 0.20		
			68,000~470,000	68,000~470,000	1.25 ± 0.20		
		100V	1,000~22,000	—	0.8 ± 0.20		
			33,000~100,000	—	1.25 ± 0.20		
		250V	1,000~4,700	—	0.8 ± 0.20		
			6,800~22,000	—	1.25 ± 0.20		
		AM06	1206	16V	1,000 ~ 330,000	1,000 ~ 330,000	0.8 ± 0.20
					680,000~3,300,000	680,000~3,300,000	1.25 ± 0.20
25V	1,000 ~ 330,000			1,000 ~ 330,000	0.8 ± 0.20		
	680,000 ~ 1,000,000			680,000 ~ 1,000,000	1.6 ± 0.30		
50V	1,000 ~ 100,000			1,000 ~ 100,000	0.8 ± 0.20		
	150,000~220,000			150,000~220,000	1.25 ± 0.20		
	330,000~680,000			330,000~680,000	1.6 ± 0.30		
100V	2,700~47,000			—	0.8 ± 0.20		
	68,000~220,000			—	1.25 ± 0.20		
250V	2,700~22,000			—	1.25 ± 0.20		
500V	1,500 ~ 33,000			—	1.25 ± 0.20		
630V	1,000 ~ 33,000			—	1.25 ± 0.20		



X7R与 X7S容量范围 Capacitance Range For X7R & X7S

单位/unit : pF

温度特性			X7R	X7S	
型号规格	尺寸规格 Size Code	额定电压 Rated Voltage	容量范围(PF) Capacitance	容量范围(PF) Capacitance	厚度标准 Thickness
AM10	1210	25V	10,000~3,300,000	10,000~3,300,000	0.8 ± 0.20
		50V	8,200~100,000	8,200~100,000	0.8 ± 0.20
			150,000~1,000,000	150,000~1,000,000	1.25 ± 0.20
		100V	4,700~100,000	—	0.8 ± 0.20
			120,000~220,000	—	1.25 ± 0.20
		250V	3,300~100,000	—	1.25 ± 0.20
		500V	1,000 ~ 56,000	—	1.25 ± 0.20
		630V	1,000 ~ 56,000	—	1.25 ± 0.20
630V	3,900 ~ 220,000	—	3.50		
AM08	1808	6.3V	10,000 ~ 4,700,000	10,000 ~ 4,700,000	2.20
		10V	10,000 ~ 4,700,000	10,000 ~ 4,700,000	2.20
		16V	10,000 ~ 2,200,000	10,000 ~ 2,200,000	2.20
		25V	6,800 ~ 2,200,000	6,800 ~ 2,200,000	2.20
		50V	4,700 ~ 1,000,000	4,700 ~ 1,000,000	2.20
		100V	3,300 ~ 1,000,000	—	2.20
		250V	1,800 ~ 220,000	—	2.20
		630V	150 ~ 100,000	—	2.20
AM12	1812	25V	15,000 ~ 10,000,000	15,000 ~ 10,000,000	3.50
		50V	12,000~2,200,000	12,000~2,200,000	3.50
		100V	10,000~1,000,000	—	3.50
		250V	5,600 ~ 820,000	—	3.50
		630V	3,900 ~ 220,000	—	3.50

备注：可根据客户的特殊要求设计符合客户需求的产品。

Note : We can design according to customer special requirements.





## 六、可靠性测试 Reliability Test

项目 Item	技术规格 Technical Specification		测试方法 Test Method and Remarks		
1、容量 Capacitance	COG	应符合指定的误差级别 Should be within the specified tolerance.	标称容量 Capacitance	测试频率 Measuring Frequency	测试电压 Measuring Voltage
			1000pF	1MHz ± 10%	1.0 ± 0.2Vrms
			> 1000 pF	1KHz ± 10%	
X7R/ X7S	应符合指定的误差级别 Should be within the specified tolerance.	测试温度：25 ± 3 Test Temperature: 25 ± 3 C 10μF：测试频率: 1KHz ± 10% 测试电压: 1.0 ± 0.2Vrms Test Frequency: 1KHz ± 10% Test Voltage: 1.0 ± 0.2Vrms C > 10μF：测试频率: 120 ± 24 Hz 测试电压: 0.5 ± 0.1Vrms Test Frequency: 120 ± 24 Hz Test Voltage: 0.5 ± 0.1Vrms			
		测试电压: 额定电压 测试时间: 60 ± 5 秒 测试湿度：75% 测试温度：25 ± 3 测试充放电电流：50mA Measuring Voltage: Rated Voltage Duration: 60 ± 5s Test Humidity: 75% Test Temperature: 25 ± 3 Test Current: 50mA			
2、绝缘电阻 (IR) Insulation Resistance	COG	C 10 nF, Ri 50000M C > 10 nF, Ri • C <sub>R</sub> 500S	测试电压: 额定电压 测试时间: 60 ± 5 秒 测试湿度：75% 测试温度：25 ± 3 测试充放电电流：50mA Measuring Voltage: Rated Voltage Duration: 60 ± 5s Test Humidity: 75% Test Temperature: 25 ± 3 Test Current: 50mA		
	X7R/ X7S	C 25 nF, Ri 10000M C > 25 nF, Ri • C <sub>R</sub> > 100S			



项目 Item	技术规格 Technical Specification		测试方法 Test Method and Remarks			
3、损耗角正切(DF, tan ) Dissipation Factor	COG	DF	标称容量 Capacitance	测试频率 Measuring Frequency	测试电压 Measuring Voltage	
		0.1%	Cr 30pF	1MHz ± 10%	1.0 ± 0.2Vrms	
		1/(400+20Cr)	Cr < 30 pF	1MHz ± 10%		
	X7R/ X7S	电压	DF	Exception		C 10μF 测试频率: 1KHz ± 10% 测试电压: 1.0 ± 0.2Vrms Test Frequency: 1KHz ± 10% Test Voltage: 1.0 ± 0.2Vrms  C > 10μF 测试频率: 120 ± 24 Hz 测试电压: 0.5 ± 0.1Vrms Test Frequency: 120 ± 24 Hz Test Voltage: 0.5 ± 0.1Vrms
		10V	5%	—		
16V		2.5%	5% ( 0402 C 27nf ; 0603 C 220nf ; 0805 C 680nf )			
25V		2.5%	3.5% ( 0402 C 10nf ; 0603 C 47nf ; 0805 C 220nf ; 1206 C 1uf )			
50V	2.5%	5% ( 0402 C 56nf ; 0805 C 680nf )				
4、介质耐电强度(DWV) Dielectric Withstanding Voltage	不应有介质被击穿或损伤 No breakdown or damage.		U <sub>r</sub> < 100V	测量电压： COG：300% 额定电压 X7R/X7S：250% 额定电压 时间：1~5 秒 充/放电电流：不应超过 50mA (这部分说明不包括中高压 MLCC) Measuring Voltage: COG:300% Rated voltage X7R/X7S:250% Rated voltage Duration: 1~5s Charge/ Discharge Current: 50mA max.		
			100 U <sub>r</sub> 630V	施加额定电压的 200%，5 秒，最大电流不超过 50mA/ Force 200%Rated voltage for 5 second.Max current should not exceed 50 mA.		



项目 Item	技术规格 Technical Specification			测试方法 Test Method and Remarks
5、外观 Appearance	无可见损伤 No visible damage			目视检查 Visual inspection
6、尺寸 Physical Dimension	在规定尺寸范围内 Within the specified dimensions			使用卡尺 Use caliper
7、可焊性 Solderability	上锡率应大于 95% 外观：无可见损伤。 At least 95% of the terminal electrode is covered by new solder. Visual Appearance: No visible damage.			将电容在 80~120 的温度下预热 10~30 秒。 Preheating conditions: 80 to 120 ; 10~30s.
	有铅焊料：(Sn/Pb : 63/37)		无铅焊料：	
8、耐焊热 Resistance to Soldering Heat	项目 Item	C0G	X7R/X7S/	将电容在 100~200 的温度下预热 60~120 秒。 浸锡温度：265 ± 5
	CC	± 0.5%	-5%~+10%	浸锡时间：10 ± 1s
	DF	同初始标准 Same to initial value.		然后取出溶剂清洗干净在 10 倍以上的显微镜底下观察 放置时间：24 ± 2 小时 放置条件：室温 Preheating conditions: 100 to 200 ; 60~120s.
	IR	同初始标准 Same to initial value.		Solder Temperature: 265 ± 5
	外观：无可见损伤 上锡率：95% Appearance : No visible damage. At least 95% of the terminal electrode is covered by new solder.			Duration: 10 ± 1s Clean the capacitor with solvent and examine it with a 10X(min.) microscope. Recovery Time: 24 ± 2h Recovery condition: Room temperature
9、偏高湿度 Biased Humidity	项目 Item	C0G	X7R/X7S	预处理（仅针对 2 类电容器）： 在 140 ~150 下预热 1 小时后，在室温下放置 24 小时。 试验条件：85 ± 2 ，80~85%R.H. 串联一个 100K ，施加额定电压和 1.3~1.5V ，1000 小时 Preconditioning , class 2 only : At 140 ~150 1 hour, then keep for 24 ± 1 hour at room temp. Test condition : 85 °C, 85% R.H. Add 100 K resistor, applied Ur and 1.3 to 1.5 volts for 1,000 hours.
	CC	± 0.5%	-5%~+10%	
	DF	同初始标准 Same to initial value.		
	IR	同初始标准 Same to initial value.		
	外观 Appearance	无可见损伤 No visible damage		



项目 Item	技术规格 Technical Specification	测试方法 Test Method and Remarks																														
10、潮湿试验 Moisture Resistance	<table border="1"> <tr> <td data-bbox="320 412 424 645">C/C</td> <td data-bbox="424 412 823 645">           C0G: <math>\pm 2\%</math> 或 <math>\pm 1\text{pF}</math>, 取两者之中较大者 X7R/X7S: <math>\pm 10\%</math> C0G: <math>\pm 2\%</math> or <math>\pm 1\text{pF}</math>, whichever is larger. X7R/X7S: <math>\pm 10\%</math> </td> </tr> <tr> <td data-bbox="320 645 424 723">DF</td> <td data-bbox="424 645 823 723">           2 倍初始标准 Not more than twice of initial value.         </td> </tr> <tr> <td data-bbox="320 723 424 1032">IR</td> <td data-bbox="424 723 823 1032">           C0G: Ri 2500M 或 Ri • Cr 25S 取两者之中较小者. C0G : Ri 2500M 或 Ri • Cr 25S whichever is smaller. X7R/X7S: Ri 1000M 或 Ri • Cr 25S 取两者之中较小者. X7R/X7S : Ri 1000M 或 Ri • Cr 25S whichever is smaller.         </td> </tr> <tr> <td colspan="2" data-bbox="320 1032 823 1111">           外观：无损伤 Appearance: No visible damage.         </td> </tr> </table>	C/C	C0G: $\pm 2\%$ 或 $\pm 1\text{pF}$ , 取两者之中较大者 X7R/X7S: $\pm 10\%$ C0G: $\pm 2\%$ or $\pm 1\text{pF}$ , whichever is larger. X7R/X7S: $\pm 10\%$	DF	2 倍初始标准 Not more than twice of initial value.	IR	C0G: Ri 2500M 或 Ri • Cr 25S 取两者之中较小者. C0G : Ri 2500M 或 Ri • Cr 25S whichever is smaller. X7R/X7S: Ri 1000M 或 Ri • Cr 25S 取两者之中较小者. X7R/X7S : Ri 1000M 或 Ri • Cr 25S whichever is smaller.	外观：无损伤 Appearance: No visible damage.		<p>温度：85 ± 2 湿度：80~85%RH 时间：500 小时 放置条件：室温 放置时间：24 小时(C0G)； 48 小时(X7R/X7S) Temperature: 85 ± 2 Humidity: 80~85%RH Duration: 500h Recovery conditions: Room temperature Recovery Time: 24h (C0G) or 48h (X7R/X7S)</p>																						
C/C	C0G: $\pm 2\%$ 或 $\pm 1\text{pF}$ , 取两者之中较大者 X7R/X7S: $\pm 10\%$ C0G: $\pm 2\%$ or $\pm 1\text{pF}$ , whichever is larger. X7R/X7S: $\pm 10\%$																															
DF	2 倍初始标准 Not more than twice of initial value.																															
IR	C0G: Ri 2500M 或 Ri • Cr 25S 取两者之中较小者. C0G : Ri 2500M 或 Ri • Cr 25S whichever is smaller. X7R/X7S: Ri 1000M 或 Ri • Cr 25S 取两者之中较小者. X7R/X7S : Ri 1000M 或 Ri • Cr 25S whichever is smaller.																															
外观：无损伤 Appearance: No visible damage.																																
11、温度循环 Temperature Cycle	<p>C/C: C0G : <math>\pm 1\%</math> 或 <math>\pm 1\text{pF}</math>, 取两者中最大者 X7R/X7S : <math>\pm 10\%</math> C0G: <math>\pm 1\%</math> or <math>\pm 1\text{pF}</math>, whichever is larger. X7R/X7S: <math>\pm 10\%</math></p>	<p>预处理（仅针对 2 类电容器）：上限类别温度，1 小时；恢复：24 ± 1h 初始测量 循环次数：1000 次,一个循环分以下 4 步：</p> <table border="1"> <thead> <tr> <th>阶段</th> <th>温度 ( )</th> <th>时间(分钟)</th> </tr> </thead> <tbody> <tr> <td>第 1 步</td> <td>下限温度 (C0G/X7R/X7S:-55)</td> <td>30</td> </tr> <tr> <td>第 2 步</td> <td>常温 (+20)</td> <td>2 ~ 3</td> </tr> <tr> <td>第 3 步</td> <td>上限温度 (C0G/X7R/X7S: +125)</td> <td>30</td> </tr> <tr> <td>第 4 步</td> <td>常温 (+20)</td> <td>2 ~ 3</td> </tr> </tbody> </table> <p>试验后放置（恢复）时间：24 ± 2h Preconditioning(class 2 only):up-category temperature, 1h ; Recovery time: 24 ± 1h Initial Measurement Cycling Times: 1000 times, 1 cycle, 4 steps:</p> <table border="1"> <thead> <tr> <th>Step</th> <th>Temperature ( )</th> <th>Time (min)</th> </tr> </thead> <tbody> <tr> <td>1</td> <td>Low- category temp. (C0G/X7R/X7S:-55)</td> <td>30</td> </tr> <tr> <td>2</td> <td>Normal temp. (+20)</td> <td>2 ~ 3</td> </tr> <tr> <td>3</td> <td>Up- category temp. (C0G/X7R/X7S: +125)</td> <td>30</td> </tr> <tr> <td>4</td> <td>Normal temp. (+20)</td> <td>2 ~ 3</td> </tr> </tbody> </table> <p>Recovery time after test: 24 ± 2h</p>	阶段	温度 ( )	时间(分钟)	第 1 步	下限温度 (C0G/X7R/X7S:-55)	30	第 2 步	常温 (+20)	2 ~ 3	第 3 步	上限温度 (C0G/X7R/X7S: +125)	30	第 4 步	常温 (+20)	2 ~ 3	Step	Temperature ( )	Time (min)	1	Low- category temp. (C0G/X7R/X7S:-55)	30	2	Normal temp. (+20)	2 ~ 3	3	Up- category temp. (C0G/X7R/X7S: +125)	30	4	Normal temp. (+20)	2 ~ 3
阶段	温度 ( )	时间(分钟)																														
第 1 步	下限温度 (C0G/X7R/X7S:-55)	30																														
第 2 步	常温 (+20)	2 ~ 3																														
第 3 步	上限温度 (C0G/X7R/X7S: +125)	30																														
第 4 步	常温 (+20)	2 ~ 3																														
Step	Temperature ( )	Time (min)																														
1	Low- category temp. (C0G/X7R/X7S:-55)	30																														
2	Normal temp. (+20)	2 ~ 3																														
3	Up- category temp. (C0G/X7R/X7S: +125)	30																														
4	Normal temp. (+20)	2 ~ 3																														



项目 Item	技术规格 Technical Specification	测试方法 Test Method and Remarks															
12、高温存储 High Temperature Exposure	C/C: COG: $\pm 1\%$ 或 $\pm 1\text{pF}$ , 取两者中最大者 X7R/X7S: $\pm 10\%$  COG: $\pm 1\%$ or $\pm 1\text{pF}$ , whichever is larger. X7R/X7S: $\pm 10\%$	温度: 最高工作温度 $125 \pm 2$ 实验电压: 不施加电压 实验时间: 1000 小时 放置条件: 室温 放置时间: 24 小时( 类); 48 小时( 类) Temperature: $125 \pm 2$ Voltage: without Duration: 1000h Recovery conditions: Room temperature Recovery Time: 24h (Class1) or 48h (Class2)															
13、振动 Vibration	<table border="1"> <thead> <tr> <th>项目 Item</th> <th>COG</th> <th>X7R/X7S</th> </tr> </thead> <tbody> <tr> <td>CC</td> <td><math>\pm 0.5\%</math></td> <td>-5%~+10%</td> </tr> <tr> <td>DF</td> <td colspan="2">同初始标准 Same to initial value.</td> </tr> <tr> <td>IR</td> <td colspan="2">同初始标准 Same to initial value.</td> </tr> <tr> <td>外观 Appearance</td> <td colspan="2">无可见损伤 No visible damage</td> </tr> </tbody> </table>	项目 Item	COG	X7R/X7S	CC	$\pm 0.5\%$	-5%~+10%	DF	同初始标准 Same to initial value.		IR	同初始标准 Same to initial value.		外观 Appearance	无可见损伤 No visible damage		5g 的力 20 分钟, 三个方向每个方向 12 个循环。 注意: 使用 8"X5" 印刷线路板, .031"厚, 在长的一边有 7 个固定点, 在对面的边的角有 2 个固定点。产品在距离固定点 2" 内安装。测试频率从 10-2000 赫兹。 5 g's for 20 minutes, 12 cycles each of 3 orientations. Note: Use 8" x 5" PCB. 0.31" thick 7 secure points on one long side and 2 secure points at corners of opposite sides. Parts mounted within 2" from any secure point. Test from 10-2000 Hz.
项目 Item	COG	X7R/X7S															
CC	$\pm 0.5\%$	-5%~+10%															
DF	同初始标准 Same to initial value.																
IR	同初始标准 Same to initial value.																
外观 Appearance	无可见损伤 No visible damage																
14 机械冲击 Mechanical Shock	<table border="1"> <thead> <tr> <th>项目 Item</th> <th>NPO</th> <th>X7R/X7S</th> </tr> </thead> <tbody> <tr> <td>CC</td> <td><math>\pm 0.5\%</math></td> <td>-5%~+10%</td> </tr> <tr> <td>DF</td> <td colspan="2">同初始标准 Same to initial value.</td> </tr> <tr> <td>IR</td> <td colspan="2">同初始标准 Same to initial value.</td> </tr> <tr> <td>外观 Appearance</td> <td colspan="2">无可见损伤 No visible damage</td> </tr> </tbody> </table>	项目 Item	NPO	X7R/X7S	CC	$\pm 0.5\%$	-5%~+10%	DF	同初始标准 Same to initial value.		IR	同初始标准 Same to initial value.		外观 Appearance	无可见损伤 No visible damage		应沿试件的 3 个互相垂直轴, 在每个方向上实施 3 次冲击试验 (共计 18 次冲击)。 脉冲波形: 正弦半波 持续时长: 0.5 毫秒 峰值: 1500g 速度变化: 4.7m/s Three shocks in each direction shall be applied along the three mutually perpendicular axes of the test specimen (18 shocks) Waveform: Half-sin Peak value: 1,500 g's Duration: 0.5 ms Velocity change: 15.4 ft/s
项目 Item	NPO	X7R/X7S															
CC	$\pm 0.5\%$	-5%~+10%															
DF	同初始标准 Same to initial value.																
IR	同初始标准 Same to initial value.																
外观 Appearance	无可见损伤 No visible damage																

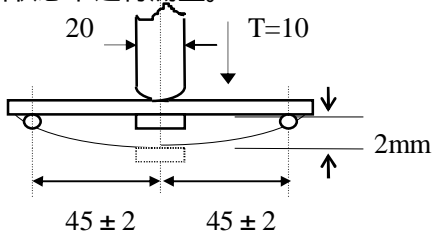

项目 Item	技术规格 Technical Specification		测试方法 Test Method and Remarks															
15、端头结合强度 Termination Adhesion	外观无可见损伤 No visible damage.		施加的力：5N      时间：10 ± 1S Applied Force: 5N      Duration: 10 ± 1S															
16、抗弯曲强度 Resistance to Flexure of Substrate (Bending Strength)	<table border="1"> <thead> <tr> <th>项目 Item</th> <th>C0G</th> <th>X7R/X7S</th> </tr> </thead> <tbody> <tr> <td>C/C</td> <td>± 0.5%</td> <td>-5%~+10%</td> </tr> <tr> <td>DF</td> <td colspan="2">同初始标准 Same to initial value.</td> </tr> <tr> <td>IR</td> <td colspan="2">同初始标准 Same to initial value.</td> </tr> <tr> <td>外观 Appearance</td> <td colspan="2">无可见损伤 No visible damage</td> </tr> </tbody> </table>		项目 Item	C0G	X7R/X7S	C/C	± 0.5%	-5%~+10%	DF	同初始标准 Same to initial value.		IR	同初始标准 Same to initial value.		外观 Appearance	无可见损伤 No visible damage		试验基板：Al <sub>2</sub> O <sub>3</sub> 或 PCB 弯曲深度：2mm 施压速度：0.5mm/sec. 单位：mm 应在弯曲状态下进行测量。  Test Board: Al <sub>2</sub> O <sub>3</sub> or PCB Warp: 2mm Speed: 0.5mm/sec. Unit: mm The measurement should be made with the board in the bending position.
项目 Item	C0G	X7R/X7S																
C/C	± 0.5%	-5%~+10%																
DF	同初始标准 Same to initial value.																	
IR	同初始标准 Same to initial value.																	
外观 Appearance	无可见损伤 No visible damage																	
17、寿命试验 Life Test	C/C	C0G : ± 2% 或 ± 1pF 取两者之中较大者 X7R/X7S : ± 20% C0G: ± 2% or ± 1pF, whichever is larger. X7R/X7S: ± 20%	电压：U <sub>r</sub> < 100V : 2.5 倍额定电压 100V U <sub>r</sub> < 500V : 2 倍额定电压 500V U <sub>r</sub> 630V : 1.5 倍额定电压 时间：1000 小时 温度：125 充电电流：不应超过 50mA 放置条件：室温 放置时间：24 小时 (C0G), 或 48 小时 (X7R/X7S), Applied Voltage: U <sub>r</sub> < 100V : 1.5× Rated Voltage 100V U <sub>r</sub> < 500V : 2× Rated Voltage 500V U <sub>r</sub> 630V : 1.5× Rated Voltage Duration: 1000h Temperature : 125 Charge/ Discharge Current: 50mA max. Recovery Conditions: Room Temperature Recovery Time: 24h (C0G), or 48h (X7R/X7S)															
DF	2 倍初始标准 Not more than twice of initial value.																	
IR	C0G : Ri 4000M 或 Ri • C <sub>R</sub> 40S 取两者之中较小者. C0G: Ri 4000M or Ri • C <sub>R</sub> 40S whichever is smaller.																	
	X7R/X7S : Ri 2000M 或 Ri • C <sub>R</sub> 50S 取两者之中较小者. X7R/X7S: Ri 2000M or Ri • C <sub>R</sub> 50S whichever is smaller.																	
外观：无损伤 Visual Appearance: No visible damage.																		



## 七、包装 PACKAGE

### 纸带卷盘结构 PAPER TAPING

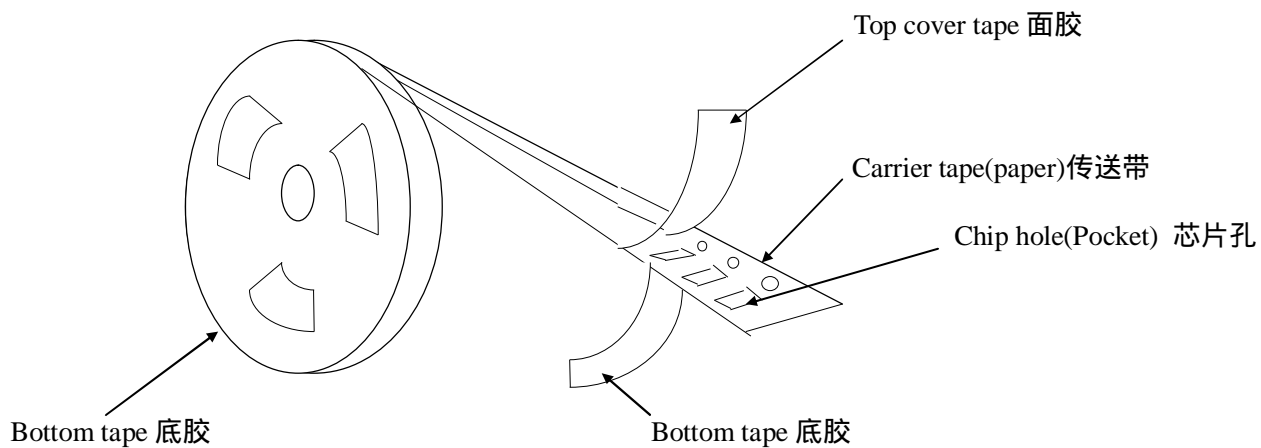

0201、0402 纸带编带尺寸大小

Dimensions of paper taping for 0402 type

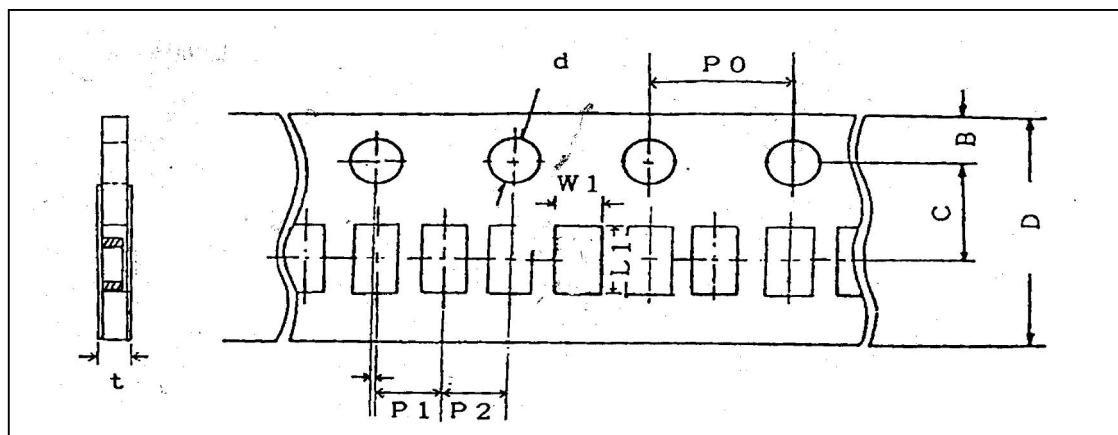

Unit : mm

代号 Code	W1	L1	D	C	B	P1	P2	P0	d	t
0201	0.37± 0.10	0.67±0. 10	8.00± 0.10	3.50± 0.05	1.75± 0.10	2.00± 0.05	2.00± 0.05	4.00±0. 10	1.50 -0/+0.10	0.80 Below
0402	0.65± 0.10	1.15± 0.10	8.00± 0.10	3.50± 0.05	1.75± 0.10	2.00± 0.05	2.00± 0.05	4.00±0. 10	1.50 -0/+0.10	0.80 Below



适合 ' 0603 , 0805 , 1206 ' 常规尺寸产品的纸带尺寸  
Dimensions of paper taping for 0603 , 0805 , 1206 types.

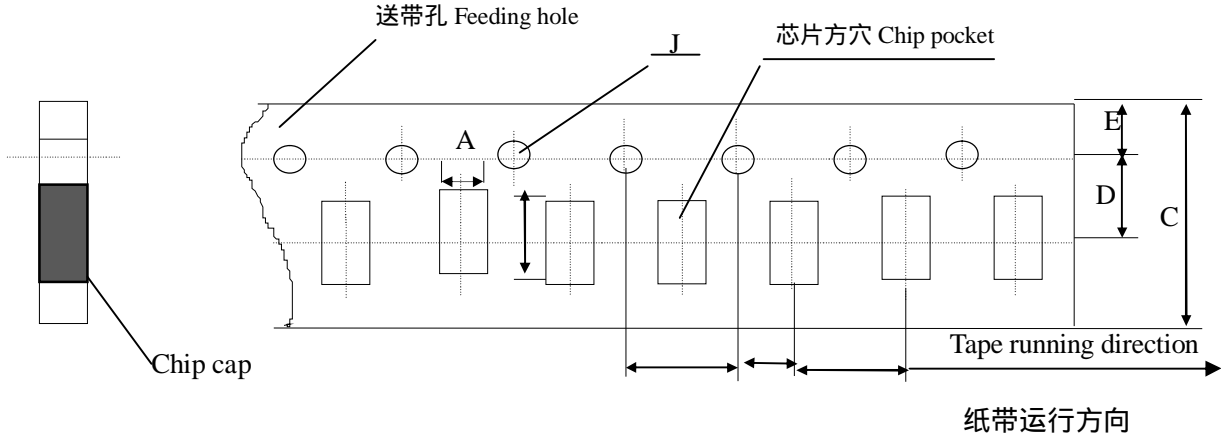

Unit : mm

代号 Code 纸带规格 paper size	A	B	C	D*	E	F	G*	H	J	T
0603	1.10 ±0.10	1.90 ±0.10	8.00 ±0.10	3.50 ±0.05	1.75 ±0.10	4.00 ±0.10	2.00 ±0.10	4.00 ±0.10	1.50 -0/+0.10	1.10 Max
0805	1.45 ±0.15	2.30 ±0.15	8.0 ±0.15	3.50 ±0.05	1.75 ±0.10	4.00 ±0.10	2.00 ±0.10	4.00 ±0.10	1.50 -0/+0.10	1.10 Max
1206	1.80 ±0.20	3.40 ±0.20	8.00 ±0.20	3.50 ±0.05	1.75 ±0.10	4.00 ±0.10	2.00 ±0.10	4.00 ±0.10	1.50 -0/+0.10	1.10 Max

注意 : \*表示此处对尺寸的要求非常精确。

Note: The place with "\*" means where needs exactly dimensions.





塑胶卷盘结构 EMBOSSED TAPING

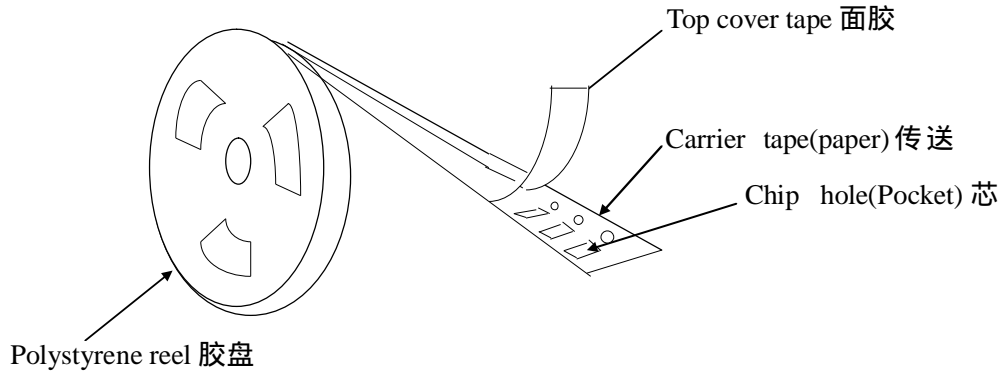

塑胶带尺寸结构(适合 '0805~1812' 型产品)

Dimensions of embossed taping for 0805~1812 type

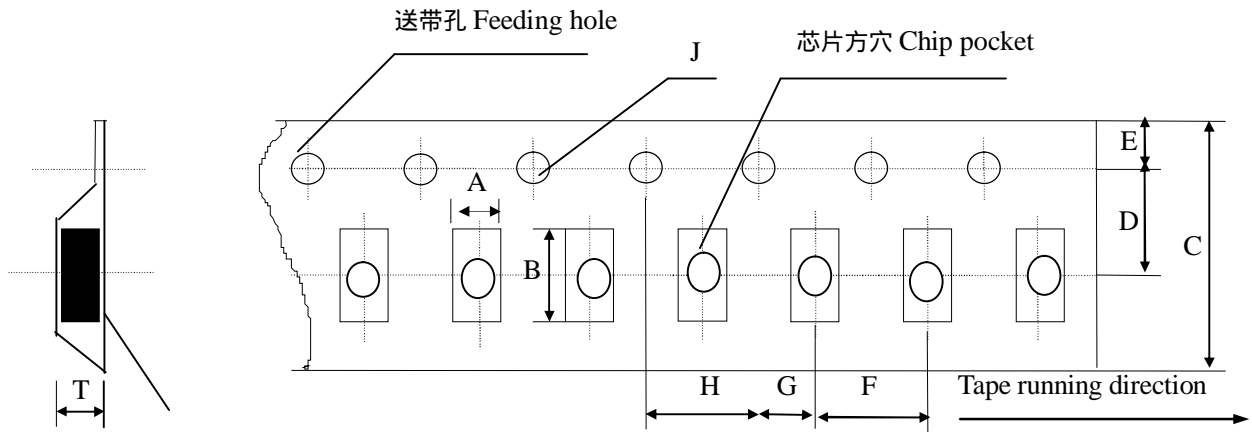

Unit : mm

代号 Code 规格 Tape size	A	B	C	D*	E	F	G*	H	J	T
0805	1.55 ±0.20	2.35 ±0.20	8.00 ±0.20	3.50 ±0.05	1.75 ±0.10	4.00 ±0.10	2.00 ±0.10	4.00 ±0.10	1.50 -0/+0.10	1.50 Max
1206	1.95 ±0.20	3.60 ±0.20	8.00 ±0.20	3.50 ±0.05	1.75 ±0.10	4.00 ±0.10	2.00 ±0.10	4.00 ±0.1	1.50 -0/+0.10	1.85 Max
1210	2.70 ±0.10	3.42 ±0.10	8.00 ±0.10	3.50 ±0.05	1.75 ±0.10	4.00 ±0.10	2.00 ±0.05	4.00 ±0.10	1.55 -0/+0.10	3.2 Max
1808	2.20 ±0.10	4.95 ±0.10	12.00 ±0.10	5.50 ±0.05	1.75 ±0.10	4.00 ±0.10	2.00 ±0.05	4.00 ±0.10	1.50 -0/+0.10	3.0 Max
1812	3.66 ±0.10	4.95 ±0.10	12.00 ±0.10	5.50 ±0.05	1.75 ±0.10	8.00 ±0.10	2.00 ±0.05	4.00 ±0.10	1.55 -0/+0.10	4.0 Max

备注：\*表示此处对尺寸的要求非常精确。

Note : The place with "\*" means where needs exactly dimensions.



传送带的前后结构 Structure of leader part and end part of the carrier paper

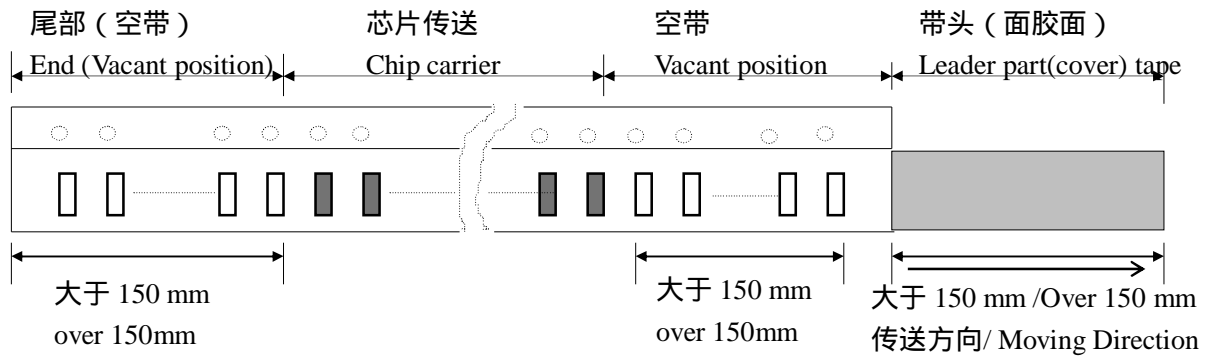

卷盘尺寸 Reel Dimensions (unit: mm)

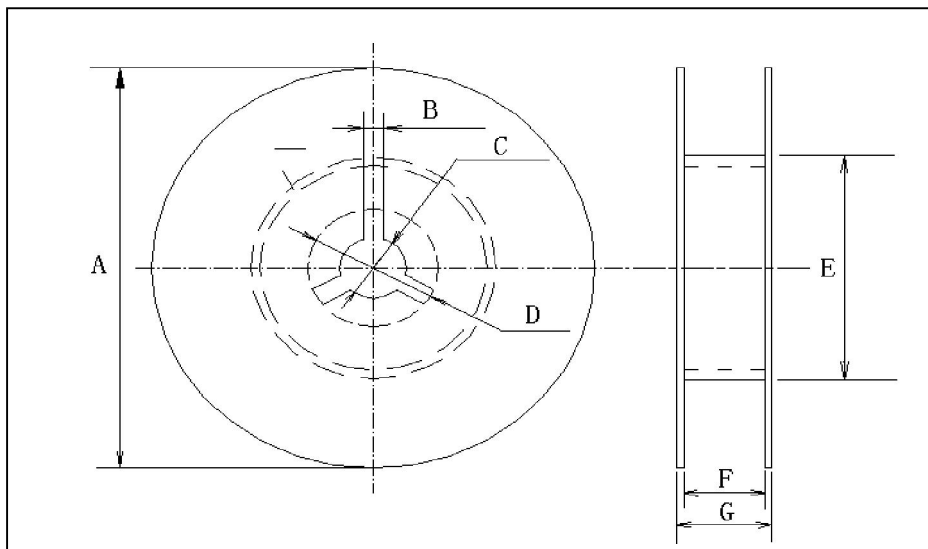

尺寸代码 (CODE)

卷盘型号	A	B	C	D	E	F	G
7 REEL	178±20	3.0	13±0.5	21±0.8	50 或更大 50 or more	100±1.5	12max
13 REEL	330±20	3.0	13±0.5	21±0.8	50 或更大 50 or more	100±1.5	12max



关于卷带的说明 Taping specification

面胶剥离强度 Top tape peeling strength

(a) 纸带 Paper Taping

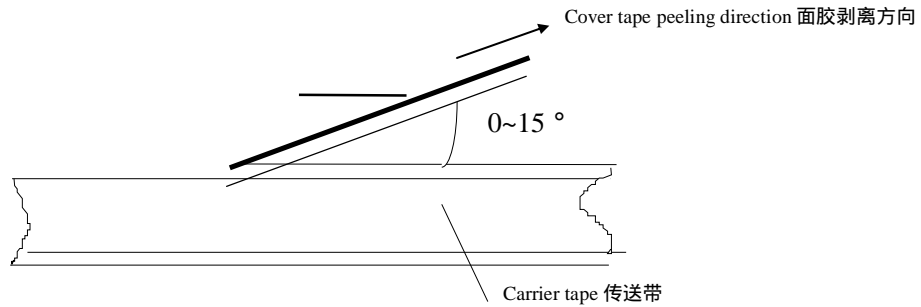

(b) 塑料胶盘 Embossed Taping

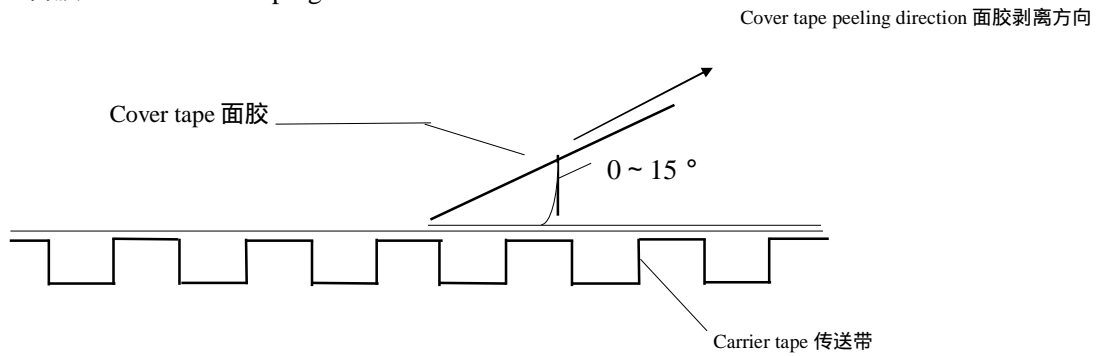

标准：0.1N < 剥离强度 < 0.7N

在剥离时，纸带不能有纸碎，也不能粘在底、面胶上。

Standard: 0.1N < peeling strength < 0.7N

No paper dirty remains on the scotch when peeling, and sticks to top and bottom tape.



塑料盒散包装 Bulk Case Package

单位 (unit) :mm

Symbol	A	B	T	C	D	E
Dimension	6.80 ± 0.10	8.80 ± 1.00	12.00 ± 0.10	15.00+0.10/-0	2.00+0/-0.10	4.70 ± 0.10
Symbol	F	W	G	H	L	I
Dimension	31.50+0.20/-0	36.00+0/-0.20	19.00 ± 0.35	7.00 ± 0.35	110.00 ± 0.70	5.00 ± 0.35

包装数量 Packing Quantity

尺寸 (SIZE)	包装形式和数量 (PACKAGE STYLE & QUANTITY) unit: pcs			
	纸带卷盘 (PT)	胶带卷盘 (ET)	塑料盒散装 (BC)	一般散装 (BP)
0201	15000	-----	20000	5000
0402	10000	-----	20000	5000
0603	4000	-----	15000	5000
0805	4000	3000	10000	5000
1206	4000	T 1.35mm 3000 T > 1.35mm 2000	5000	5000
1210	-----	T 1.80mm 2000 T > 1.80mm 1000	-----	2000
1410	-----	2000	-----	-----
1808	-----	2000	-----	2000
1812	-----	T 1.85mm 1000 T > 1.85mm 500	-----	2000

注意：包装的形式和数量可根据客户的要求来定。

Note : We can choose packing style and quantity can be according to the customer's requirement.



## 外包装 Outer packing

小包装 The first package

Quantity: 10 reels

数量：10卷

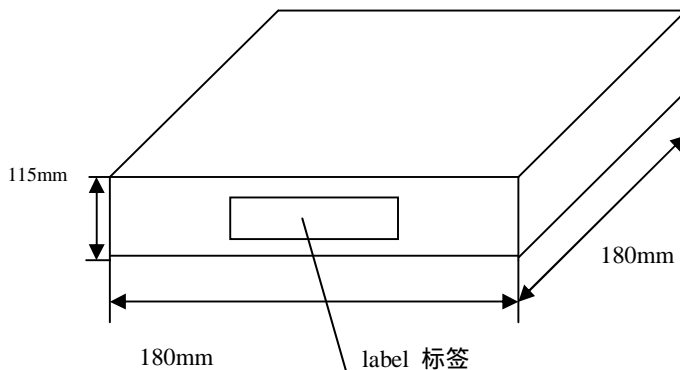

PART No 型号规格  
QUANTITY 数量  
DATE 日期

大包装 The second package

Quantity: 6 cases

数量：6盒

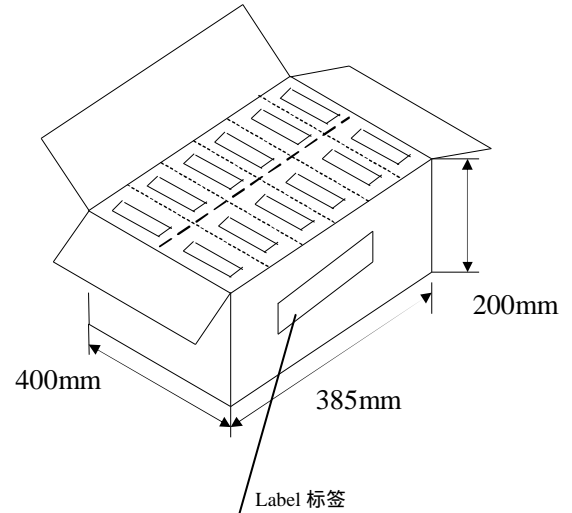

Production name 产品名称  
Quantity 数量  
Weight 重量

## 八、储存方法 Storage Methods

确保芯片可焊性良好的贮存期限为6个月(在包装好已交付的情况下)。

The guaranteed period for solderability is 6 months (Under deliver package condition).

储存条件/Storage conditions :

储存温度/Temperature 5~40

储存相对湿度/Relative Humidity 20~70%

## 九、使用前的注意事项 Precautions For Use

多层片式瓷介电容器(MLCC)在短路或开路的电路中都有可能失效,在超出本承认书或相关说明书中所述使用频率的恶劣工作环境,或外界机械力超压作用下,电容芯片都有可能着火、燃烧甚至爆炸,所以在使用的時候,首先应考虑按本承认书的有关说明来进行,如有不明之处,请联系我们技术部、品管部或生产部。

The Multi-layer Ceramic Capacitors (MLCC) may fail in a short circuit modern in an open circuit mode when subjected to severe conditions of electrical environment and / or mechanical stress beyond the specified "rating" and specified "conditions" in the specification, which will result in burn out, flaming or glowing in the worst case. Following "precautions for "safety" and Application Notes shall be taken in your major consideration. If you have a question about the precautions for handling, please contact our engineering section or factory.



### 1. 焊接的条件与相关图表 Soldering Profile

为避免因温度的突然变化而引起的芯片开裂或局部爆炸的现象发生,请按有关温度曲线图表来进行。(请参考附页中的图表)

To avoid the crack problem by sudden temperature change, follow the temperature profile in the adjacent graph (refer to the graph in the enclosure page).

### 2. 手工焊接 Manual Soldering

手工焊接很容易因为芯片局部受热不均而引起瓷体微裂或局部爆炸的现象,在焊接时,如果操作者不小心,会使烙铁头直接同电容芯片的瓷体部分接触,这样很容易使电容芯片因热冲击而受损或出现其他意外.因此,使用电烙铁手工焊接时应仔细操作,并对电烙铁的尖端的选择和尖端温度控制应多加小心.

Manual soldering can pose a great risk of creating thermal cracks in capacitors. The hot soldering iron tip comes into direct contact with the end terminations, and operator's careless may cause the tip of the soldering iron to come into direct contact with the ceramic body of the capacitor. Therefore the soldering iron must be handled carefully, and pay much attention to the selection of the soldering iron tip and temperature contact of the tip.

### 3. 适量的焊料 Optimum Solder Amount for Reflow Soldering

焊料过多  
Too much solder

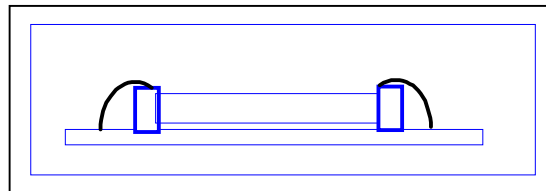

这样会因端头压力过大而可能引起芯片受损  
Cracks tend to occur due to large stress

焊料太少  
Not enough solder

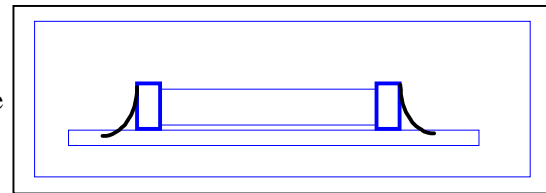

固定力量不足,可能会引起电容芯片与线路接触不良  
Weak holding force may cause bad connection between the capacitor and PCB.

### 4. 推荐焊料用量 Recommended Soldering amounts

#### 4.1 回流焊接的最佳焊料用量

The optimal solder fillet amounts for re-flow soldering

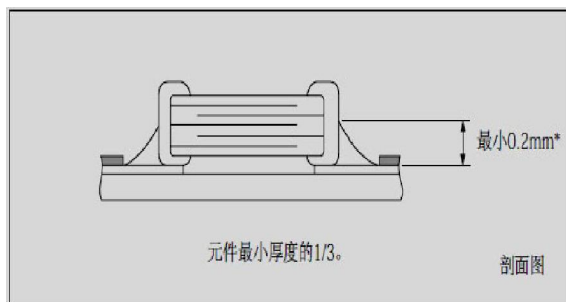

#### 4.2 波峰焊接的最佳焊料用量

The optimal solder fillet amounts for wave soldering

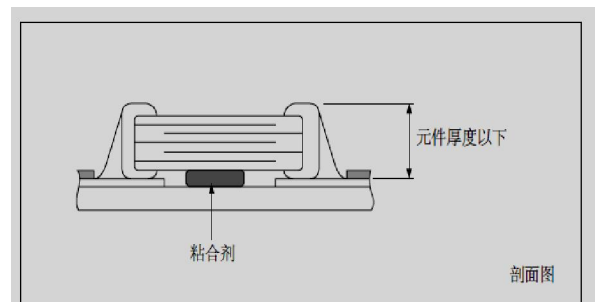



#### 4.3 使用烙铁返修时的最佳焊料量

The optimal solder fillet amounts for reworking by using soldering iron

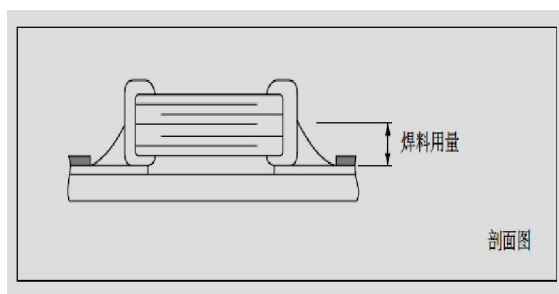

### 十、推荐焊接方式 Recommended Soldering Method

规格尺寸 Size	温度特性 Temperature Characteristics	额定电压 Rated Voltage	容量范围 Capacitance	焊接方式 Soldering Method
0201	NPO	/		R
	X7R /X7S	/		R
0402	NPO	/		R
	X7R /X7S	/		R
0603	NPO	/		R/W
	X7R /X7S	/	C 1uf	R
			C < 1uf	R/W
0805	NPO	/	/	R/W
	X7R /X7S	/	C 4.7uf	R
			C < 4.7uf	R/W
1206	NPO	/	/	R/W
	X7R /X7S	/	C 10uf	R
			C < 10uf	R/W
1210	NPO	/	/	R
	X7R /X7S	/	/	R

焊接方式 Soldering method : R—回流焊 Reflow Solering

W—波峰焊 Wave Soldering

十一、推荐焊接温度曲线图 The temperature profile for soldering  
回流焊接 ( Re-flow soldering )

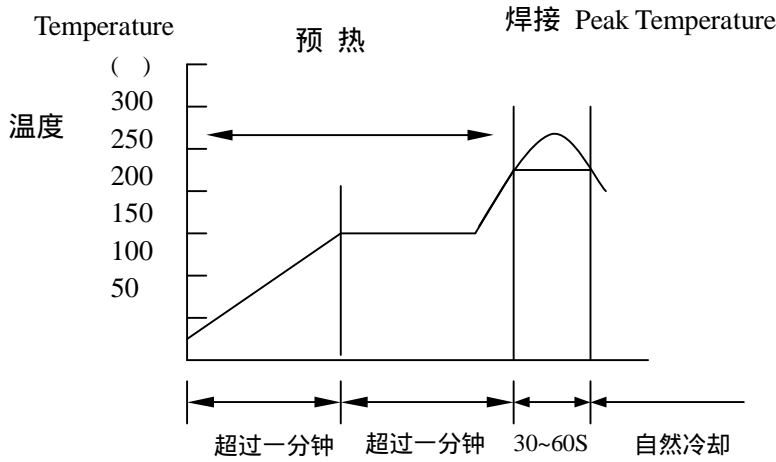

	Pb-Sn 焊接 Pb-Sn soldering	无铅焊接 Lead-free soldering
尖峰温度 Peak temperature	230 ~ 250	240 ~ 260

在预热时, 请将焊接温度与芯片表面温度之间的温差维持在  $T = 150$  。

While in preheating, please keep the temperature difference between soldering temperature and surface temperature of chips as:  $T = 150$  .

波峰焊接 ( Wave soldering )

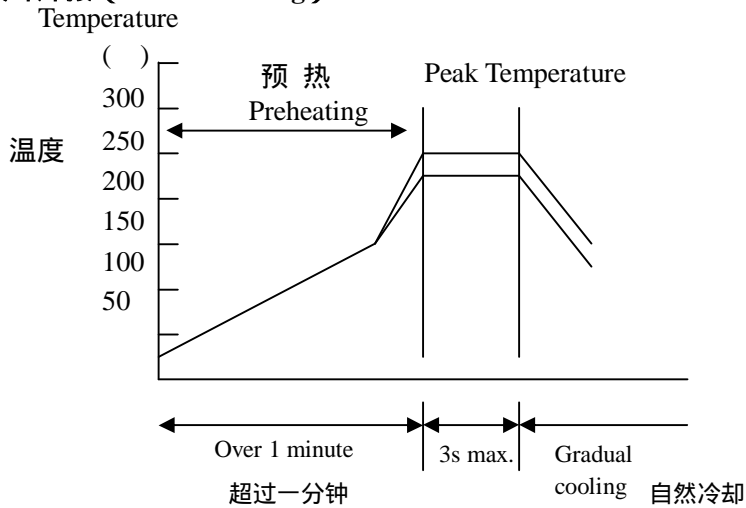

	Pb-Sn 焊接 Pb-Sn soldering	无铅焊接 Lead-free soldering
尖峰温度 Peak temperature	230 ~ 260	240 ~ 270

在预热时, 请将焊接温度与芯片表面温度之间的温差维持在  $T = 150$  。

While in preheating, please keep the temperature difference between soldering temperature and surface temperature of chips as:  $T = 150$  .





### 手工焊接 (Hand soldering)

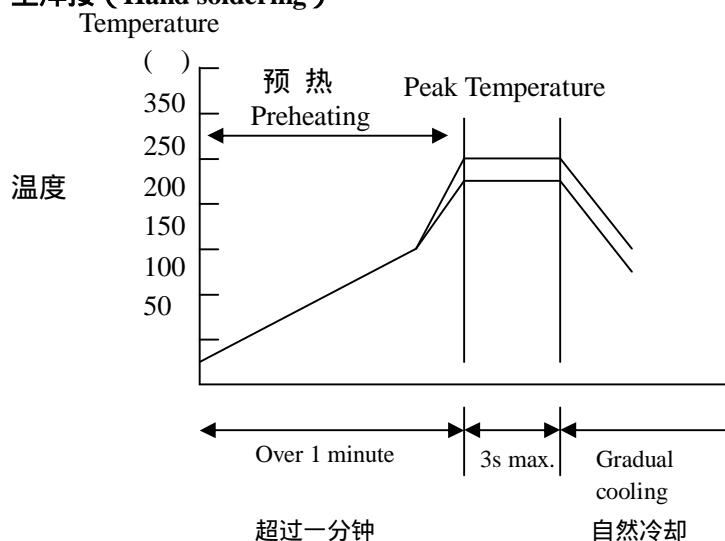

条件 Conditions :

预热 Preheating	烙铁头温度 Temperature of soldering iron head	烙铁功率 Power of soldering iron	烙铁头直径 Diameter of soldering iron head	焊接时间 Soldering time	锡膏量 Solder paste amount	限制条件 Restricted conditions
130	最高350 Highest temperature:350	最大20W 20W at the highest	建议1mm 1mm recommended	最长3s 3s at the longest	1/2 芯片厚度 1/2 chip thickness	请勿使用烙铁头直接接触陶瓷元件 Please avoid the direct contact between soldering iron head and ceramic components

以最新版本的内容为准

编号：GH-ZD4132P

版本号：1



广东风华高新科技股份有限公司  
GUANGDONG FENGHUA ADVANCED TECHNOLOGY HOLDING CO., LTD.

# 承 认 书

## APPROVAL SHEET

客户名称

CUSTOMER : \_\_\_\_\_

产品名称

汽车电子多层片式陶瓷电容器

PART NAME : \_\_\_\_\_ AUTOMOTIVE MLCC

规格

SPECIFICATION: \_\_\_\_\_ 0201 ~ 1812 TYPE

版本

VERSION: \_\_\_\_\_

日期

DATE OF ISSUE : \_\_\_\_\_

制 造 MANUFACTURER			客 户 CUSTOMER		
拟制 DESIGN	审核 CHECK	批准 APPROVAL	检验 INSPECTOR	审核 CHECK	批准 APPROVAL

单击下面可查看定价，库存，交付和生命周期等信息

[>>FH\(风华高科\)](#)