

RECOMMENDED PCB LAYOUT
GENERAL TOLERANCE ± 0.05

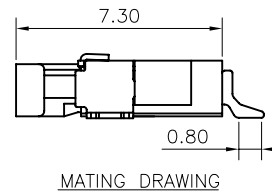
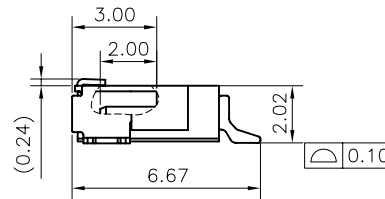

NOTES:

1. MATERIAL:

- 1.1 HOUSING: THERMOPLASTIC, HIGH TEMP, UL94V-0; COLOR: BLACK;LCP
- 1.2 CONTACT: COPPER ALLOY(BRASS)
- 1.3 SHELL: COPPER ALLOY(NICKEL SLIVER)

2. FINISH:

CONTACT:

- 50~100u" NICKEL UNDERPLATING OVERALL.
- 1:CONTACT POINT: GOLD 3u"MIN
- SOLDER TAIL: GOLD 1u" MIN
- U:CONTACT POINT: GOLD 5u"MIN
- SOLDER TAIL: GOLD 1u" MIN
- T:CONTACT POINT: GOLD 10u"MIN
- SOLDER TAIL: GOLD 1u" MIN

3. REFLOW SOLDER CAPABLE TO 260°C PER ACES SPEC.

- 4. SPEC. PLS. REFER TO SPEC-50458-XXXX-XXX
- 5. PACKAGE PLS. REFER TO 50458-XXXX-XX-TRP
- 6. PART NUMBER

50458-XXX X X-XXX

NO OF CKT	TYPE	PACKING	SHELL
	001	50458-XXXX-XX-TRP	SMT TYPE, PLS SEE PAGE 1

PACKING
0: TAPE & REEL
1: Tube

PLATING
1: GOLD FLASH
U: CONTACT POINT: GOLD 5u"MIN
SOLDER TAIL: GOLD 1u" MIN
T: CONTACT POINT: GOLD 10u"MIN
SOLDER TAIL: GOLD 1u" MIN

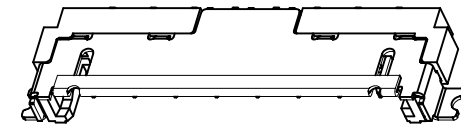

CKTS	DIMA	DIMB	DIMC	DIMD	DIME
006	10	10.00	17.2	12.2	15.7
007	12	12.00	19.2	14.2	17.7
008	14	14.00	21.2	16.2	19.7
009	16	16.00	23.2	18.2	21.7
010	18	18.00	25.2	20.2	23.7

一般公差 TOLERANCES X ± 0.5 .XX ± 0.15 X ± 0.25 .XXX ± 0.1 ANGLES $\pm 2^\circ$		宏致電子股份有限公司 Aces Electronics Co.,Ltd.	
檢驗尺寸標示 SYMBOLS ⊕ ⊗ INDICATE CLASSIFICATION DIMENSION ⊕ MARK IS CRITICAL DIM. ⊗ MARK IS MAJOR DIM.	品名 (TITLE) 2.0MM WTB WAFER CONN. SMT R/A TYPE	製圖 (DR) '16/05/17 審核 (CHKD) BRAVE	COCOYU
	圖號 (DWG NO.) 50458-XXXX-XXX	核准 (APPD) FRANK	
表面處理 (FINISH)	比例 (SCALE) 1:1	單位 (UNITS) mm	張數 (SHEET) 1 OF 2 SIZE A4 REV E

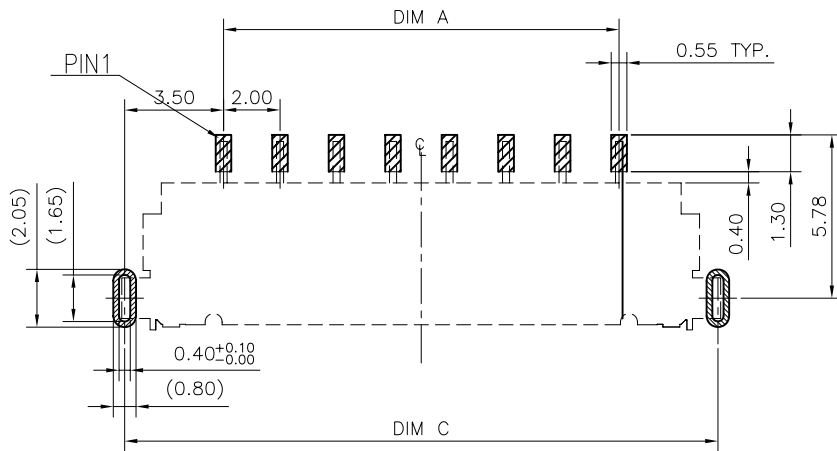
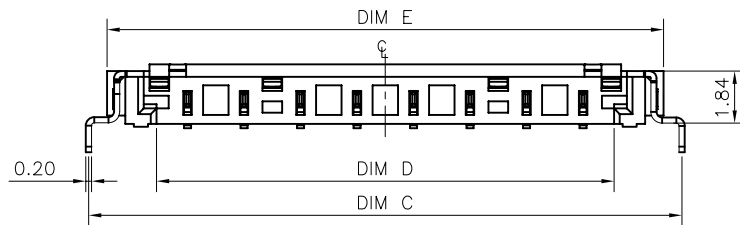
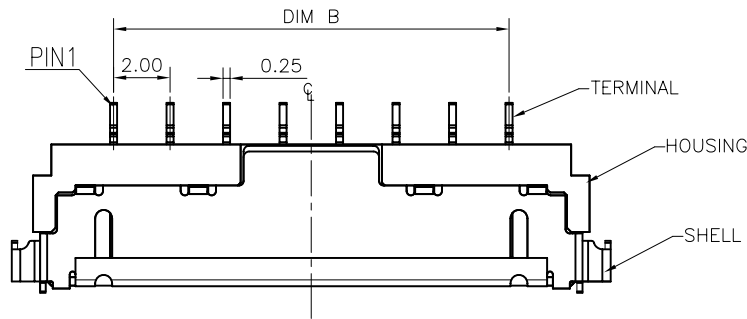

RECOMMENDED PCB LAYOUT
GENERAL TOLERANCE ±0.05

NOTES:

- MATERIAL:
 - HOUSING: LCP THERMOPLASTIC, HIGH TEMP., UL94V-0; COLOR: BLACK;
 - CONTACT: COPPER ALLOY(BRASS)
 - SHELL: COPPER ALLOY(NICKEL SLIVER)
- FINISH: CONTACT:
 - 50~100u" NICKEL UNDERPLATING OVERALL.
 - 1:CONTACT POINT: GOLD 3u"MIN
SOLDER TAIL: GOLD 1u" MIN
 - U:CONTACT POINT: GOLD 5u"MIN
SOLDER TAIL: GOLD 1u" MIN
 - T:CONTACT POINT: GOLD 10u"MIN
SOLDER TAIL: GOLD 1u" MIN
- REFLOW SOLDER CAPABLE TO 260°C PER ACES SPEC.
- SPEC. PLS. REFER TO SPEC-50458-XXXX-XXX
- PACKAGE PLS. REFER TO 50458-XXXX-05-TRP
- PART NUMBER

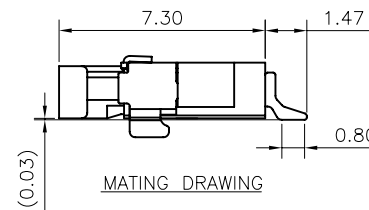
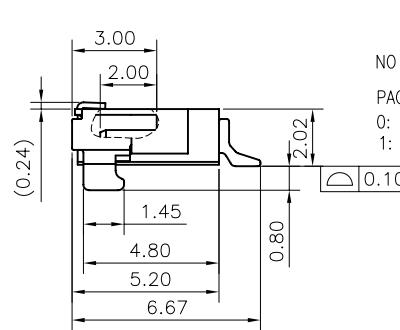

50458-XXX X X-XXX

NO OF CKT
PACKING
0: TAPE & REEL
1: Tube

TYPE	PACKING	SHELL
002	50458-XXXX-05-TRP	DIP TYPE, PLS SEE PAGE 2

PLATING

- 1: GOLD FLASH
- U: CONTACT POINT: GOLD 5u"MIN
SOLDER TAIL: GOLD 1u" MIN
- T: CONTACT POINT: GOLD 10u"MIN
SOLDER TAIL: GOLD 1u" MIN

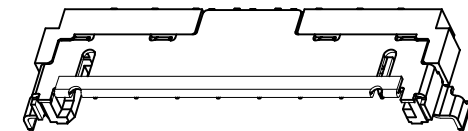

CKTS	DIMA	DIMB	DIMC	DIMD	DIME
006	10	10.00	17.0	12.2	15.7
007	12	12.00	19.0	14.2	17.7
008	14	14.00	21.0	16.2	19.7
009	16	16.00	23.0	18.2	21.7

一般公差
TOLERANCES
X ±0.5 .XX ±0.15
X ±0.25 .XXX ±0.1
ANGLES ±2°

宏致電子股份有限公司
Aces Electronics Co.,Ltd.

檢驗尺寸標示
SYMBOLS ① ② INDICATE CLASSIFICATION DIMENSION
① MARK IS CRITICAL DIM.
② MARK IS MAJOR DIM.

品名 (TITLE)
2.0MM WTB WAFER CONN.
SMT R/A TYPE
圖號 (DWG.NO)
50458-XXXX-XXX

製圖 (DR)
'16/05/17
審核 (CHKD)
BRAVE
核准 (APPD)
FRANK

表面處理 (FINISH)

比例 (SCALE)
1:1

單位 (UNITS)
mm

張數 (SHEET)
2 OF 2
SIZE
A4
REV
E

单击下面可查看定价，库存，交付和生命周期等信息

[>>ACES\(宏致\)](#)