

**PRODUCT  
DATASHEET**



**CLM3820 45A Series Device**

## CLM3820 45A Series Device

### Description

Current Limiting Module (CLM) is a chip type surface mountable device that can protect against both overcurrent and overcharging. It comprises a fuse element to ensure stable operation under normal electrical current and to cut off the current when overcurrent occurs. It also comprises a resistive heating element that could be used in combination with a voltage detecting means, such as IC and FET. When overvoltage is detected, the heating element is electrically excited to generate heat to blow the fuse element to achieve overvoltage protection.



### Features

- Halogen-free
- Surface mountable
- Overcharging protection
- Fast response time
- Overcurrent protection

### Application



- Self Balancing
- Automotive applications
- E-Bike
- Energy Storage systems
- Power Tool
- Drone

### Agency Approval and Environmental Compliance

Agency	File Number	Regulation	Standard
	E331807		IEC 61249-2-21:2003
	TA 50428400		

RoHS Directive: Compliance (this product complies with RoHS exemption requirements)

### Electrical Specifications

Part Number	I <sub>rated</sub> (A)	Cells in series	V <sub>max</sub> (V <sub>dc</sub> )	I <sub>break</sub> (A)	V <sub>OP</sub> (V)	Resistance		Agency Approval	
						R <sub>heater</sub> (Ω)	R <sub>fuse</sub> (mΩ)		
CLM3820P1245	45	3	62	120	9.8 ~ 13.5	1.9 ~ 3.4	0.4 ~ 2.0	✓	✓
CLM3820P1445	45	4	62	120	13.0 ~ 18.4	3.4 ~ 6.0	0.4 ~ 2.0	✓	✓
CLM3820P2045	45	5	62	120	16.7 ~ 23.5	5.6 ~ 9.9	0.4 ~ 2.0	✓	✓
CLM3820P3045	45	6~7	62	120	22.3 ~ 31.5	10.0 ~ 17.7	0.4 ~ 2.0	✓	✓
CLM3820P4045	45	9~10	62	120	33.0 ~ 46.9	22.0 ~ 38.7	0.4 ~ 2.0	✓	✓
CLM3820P5045	45	12~14	62	120	43.7 ~ 62.0	38.5 ~ 68.0	0.4 ~ 2.0	✓	✓

## CLM3820 45A Series Device

### Electrical Characteristics

Current Capacity	100% x $I_{rated}$ No Melting
Cut Time	200% x $I_{rated}$ < 1 min
Interrupting Current	150A, power on 5 ms, power off 995 ms, 10000 cycles No Melting
Over Voltage Operation	In operation voltage range, the fusing time is <1min.

### Note on Electrical Specifications & Characteristics

#### ■ Vocabulary

- $I_{rated}$  = Current carrying capacity that is measured at 40°C thermal equilibrium condition.  
 $I_{break}$  = The current that the fuse element is able to interrupt.  
 $V_{max}$  = The maximum voltage that can be cut off by fuse.  
 $V_{op}$  = Range of operation voltage.  
 $R_{heater}$  = The resistance of the heating element.  
 $R_{fuse}$  = The resistance of the fuse element.

Cells in series = Number of battery cells connected in series in the circuit for CLM device to protect.

- Value specified is determined by using the PWB with 25mm\*2oz copper traces, AWG8 covered wire, and 0.6mm glass epoxy PCB.
- Specifications are subject to change without notice.

### ▲ WARNING

#### ■ General

- Before and after mounted, the ultrasonic-cleaning or immersion-cleaning must not be done to CLM device. The flux on element would flow, and it would not be satisfied its specification when cleaning is done. In addition, a similar influence happens when the product comes in contact with cleaning-solution. These products after cleaning will not be guaranteed.
- Silicone-based oils, oils, solvents, gels, electrolytes, fuels, acids, and the like will adversely affect the properties of CLM devices, and shall not be used or applied.
- Please Do Not reuse the CLM device removed by the soldering process.
- CLM devices are secondary protection devices and are used solely for sporadic, accidental over-current or over-temperature error condition, and shall NOT be used if or when constant or repeated fault conditions (such fault conditions may be caused by, among others, incorrect pin-connection of a connector) or over-extensive trip events may occur.
- Operation over the maximum rating or other forms of improper use may cause failure, arcing, flame and/or other damage to the CLM devices.
- The performance of CLM devices will be adversely affected if they are improperly used under electronic, thermal and/or mechanical procedures and/or conditions non-conformant to those recommended by manufacturer.
- Customers shall be responsible for determining whether it is necessary to have back-up, failsafe and/or fool-proof protection to avoid or minimize damage that may result from extra-ordinary, irregular function or failure of CLM devices.
- There should be minimum of 0.1mm spacing between CLM and surrounding compounds, to maintain the product characteristics and avoid damage other surrounding compounds.
- This product is designed and manufactured only for general-use of electronics devices. We do not recommend that it is used for the applications Military, Medical and so on which may cause direct damages on life, bodies or properties.

## CLM3820 45A Series Device

### Thermal Derating Characteristics

Ambient Temperature (°C)	25	40	60
Recommend Rated Current (A)	49.0	44.5	37.0

### Cut Time by Heater Operation

■ Various heater wattage at 25°C ambient temperature.

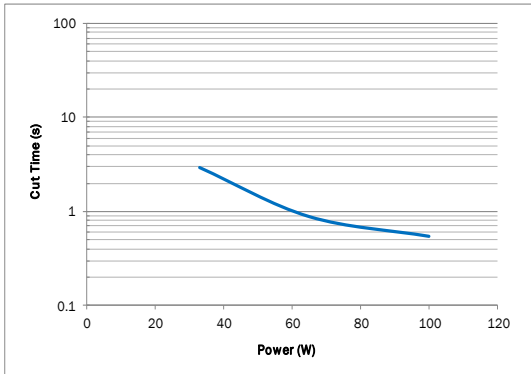

■ Constant heater wattage at various ambient temperature.

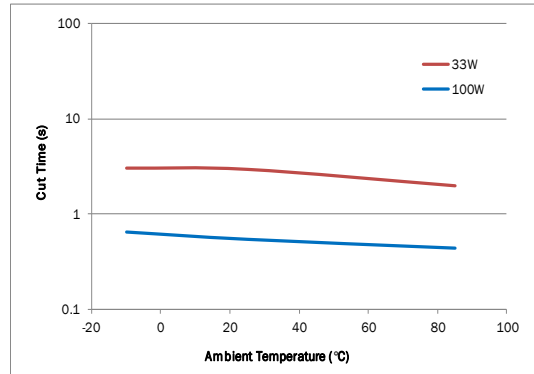

### Cut Time by Current Operation

■ Various interrupting current at 25°C ambient temperature.

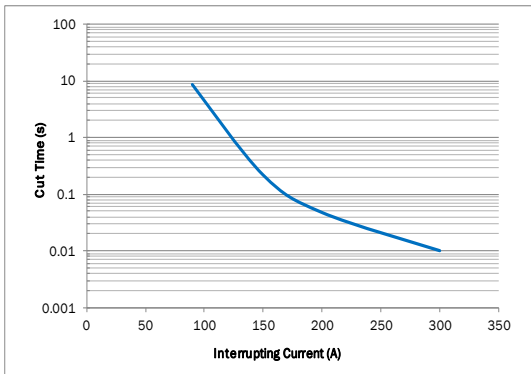

■ Constant 2x rated current at various ambient temperature.

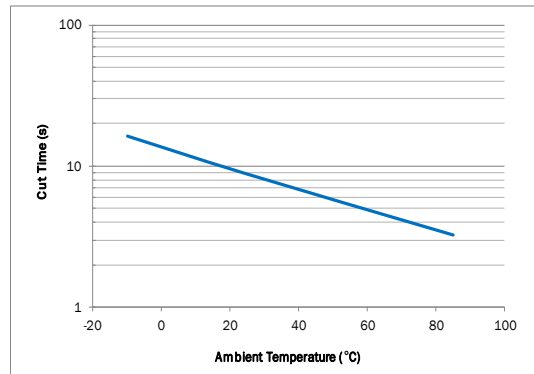

## CLM3820 45A Series Device

### Device Circuit

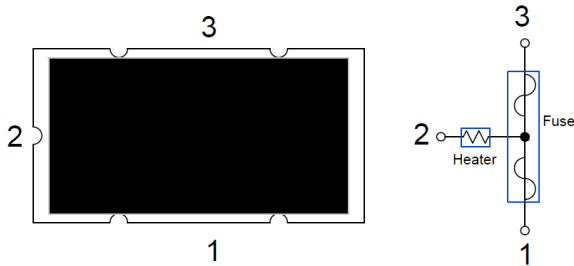

### Physical Dimensions (mm.)

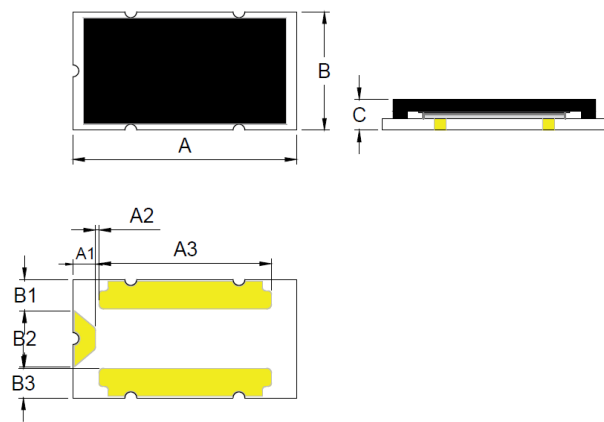

A	9.50 ± 0.2
B	5.00 ± 0.3
C	2.00 max
A1	0.89 ± 0.1
A2	0.15 ± 0.1
A3	7.32 ± 0.1

B1	1.32 ± 0.1
B2	2.36 ± 0.1
B3	1.25 ± 0.1

### Environmental Specifications

Storage Temperature	0~35°C, ≤70%RH 3 months after shipment
Operating Temperature	-10°C to +65 °C
Hot Passive Aging	100±5°C, 250 hours No structural damage and functional failure
Humidity Aging	60°C±2°C, 90~95%R.H. 250 hours No structural damage and functional failure
Cold Passive Aging	-20±3°C, 500 hours No structural damage and functional failure
Thermal Shock	MIL-STD-202 Method 107G +125°C /-55°C, 100 times No structural damage and functional failure

### Board and Solder Layout Recommend (mm)

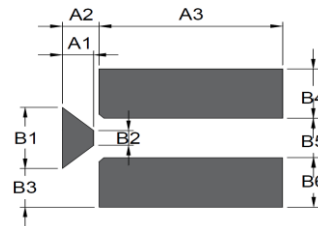

Material	Glass Epoxy PCB
Base Thickness	0.6mm
Copper Thickness	0.07mm
Covered Wire	AWG8

A1	1.30 ± 0.1
A2	1.52 ± 0.1
A3	7.60 ± 0.1

B1	3.10 ± 0.1
B2	0.75 ± 0.1
B3	1.95 ± 0.1
B4	2.50 ± 0.1
B5	2.00 ± 0.1
B6	2.50 ± 0.1

### Part Number System

#### CLM 3820 P 12 45

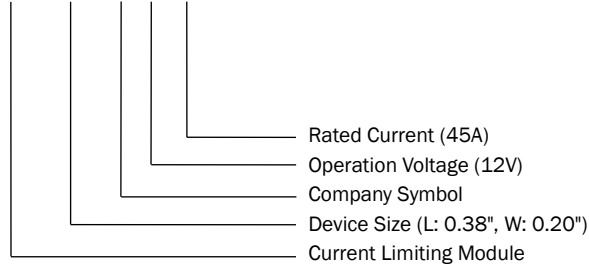

### Part Marking System

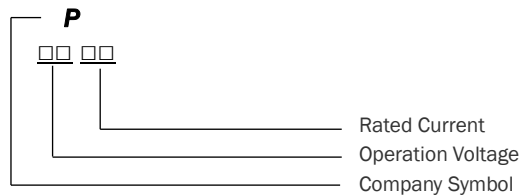

## CLM3820 45A Series Device

### Soldering Parameters

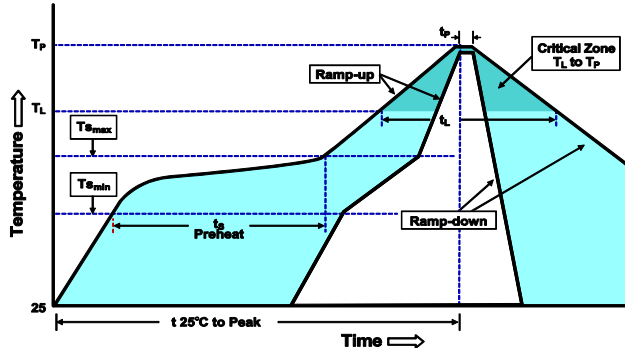

Average Ramp-Up Rate (T <sub>smax</sub> to T <sub>P</sub> )	3°C/second max.
Preheat	
-Temperature Min (T <sub>smin</sub> )	150°C
-Temperature Max (T <sub>smax</sub> )	200°C
-Time (T <sub>smin</sub> to T <sub>smax</sub> )	60-120 seconds
Time maintained above:	
-Temperature (T <sub>L</sub> )	217°C
-Time (t <sub>L</sub> )	60-105 seconds
Peak Temperature (T <sub>P</sub> )	255°C
Time within 5°C of actual Peak	
Temperature (t <sub>P</sub> )	5 seconds max.
Ramp-Down Rate	6°C /second max.
Time 25°C to Peak Temperature	8 minutes max.

Note 1: The temperature shown above is the top-side surface temperature of the device.  
Note 2: If the soldering temperature profile deviates from the recommended profile, devices may not meet the performance requirements

### Tape & Reel Specification (mm.)

Devices are packaged per EIA481 and EIA-2 standard

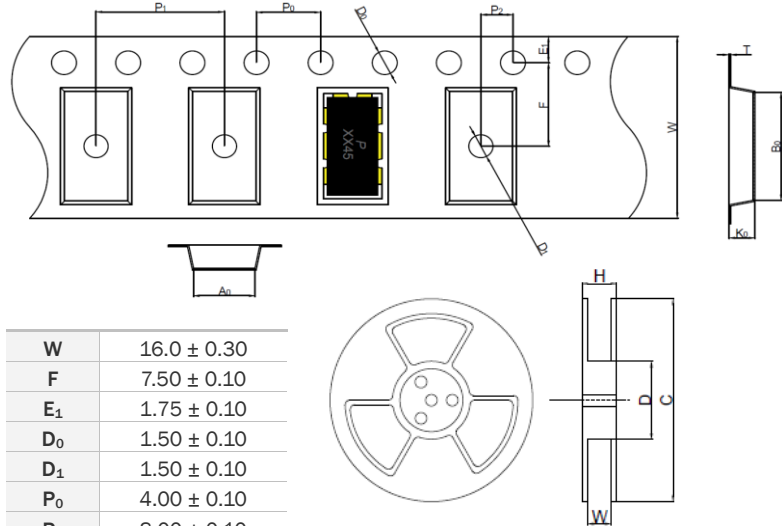

W	16.0 ± 0.30
F	7.50 ± 0.10
E <sub>1</sub>	1.75 ± 0.10
D <sub>0</sub>	1.50 ± 0.10
D <sub>1</sub>	1.50 ± 0.10
P <sub>0</sub>	4.00 ± 0.10
P <sub>1</sub>	8.00 ± 0.10
P <sub>2</sub>	2.00 ± 0.10
A <sub>0</sub>	5.40 ± 0.10
B <sub>0</sub>	9.85 ± 0.10
T	0.30 ± 0.05
K <sub>0</sub>	2.48 ± 0.10

H	21.4 ± 1.0
W	17.4 ± 1.0
D	Ø99.0 ± 0.5
C	Ø330 ± 1.0

### Packaging Quantity

Part Number	Tape & Reel Quantity
CLM3820PXX45	1000

单击下面可查看定价，库存，交付和生命周期等信息

[>>聚鼎](#)