

CUSTOMER DRAWING

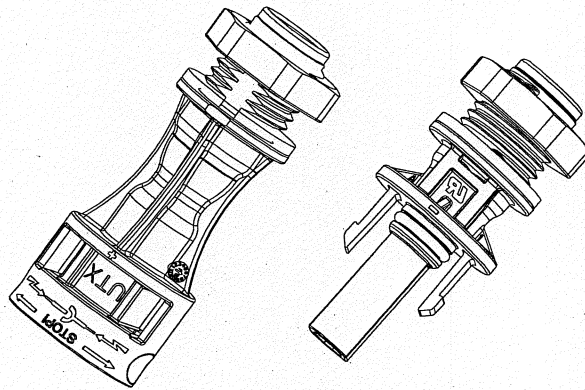

UTX BULKHEAD M14

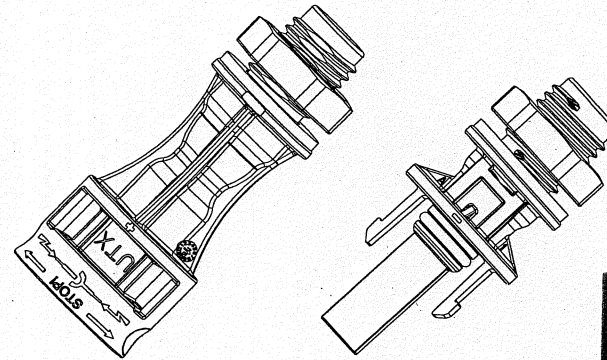

UTX BULKHEAD M12

ORIGINAL COPY (正原版)
12 JAN 2016
DOCUMENT CONTROL

REVISIONS		
LTR	DESCRIPTION	DATE
A	INITIAL RELEASE	2015-09-29
B	ADD C&F CONTACT AND M12 BULKHEAD INFORMATION	2016-01-12

I. SPECIFICATIONS

DESCRIPTIONS	SPECIFICATIONS			CERTIFICATE NO.
	CONTACT SIZE			
RATED CURRENT	2.5mm ² /14AWG	4.0mm ² /12AWG	6.0mm ² /10AWG	
TUV(85°C)	31A	42A	53A	R 50283691
UL	15A	20A	30A	E469330
RATED SYSTEM VOLTAGE	1500VDC			
DEGREE OF PROTECTION (MATED)	IP68			
CONTACT MATERIAL	COPPER, TIN PLATED			
INSULATION MATERIAL	THERMOPLASTIC			
AMBIENT TEMPERATURE RANGE	-40 °C TO +90 °C			
CABLE APPLICABILITY	UL PV WIRE (14/12/10AWG) TUV PVI-F WIRE (2.5/4/6mm ²)			
CONTACT RESISTANCE	0.30mΩ for S&F contact 0.25mΩ for C&F contact			
APPLICATION CLASS	CLASS A			
FLAMMABILITY RATING	UL94 V-0			

NOTES:

THIS DOCUMENT CONTAINS PROPRIETARY INFORMATION AND SUCH INFORMATION MAY NOT BE DISCLOSED TO OTHERS FOR ANY PURPOSE OR USED FOR MANUFACTURING PURPOSES WITHOUT WRITTEN PERMISSION FROM THE AMPHENOL CORP.

N/A	NEXT ASSEMBLY
METRIC DOCUMENT	

PRO/ENGINEER INFORMATION
Pro/Model Used:
PV-693376-01-ASSEM
Drawing Name:
PV-693376-BULKHEAD.CDS

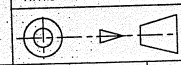
UNLESS OTHERWISE SPECIFIED	SPECIFICATIONS	POS	QTY	PART NUMBER	DESCRIPTION	NOTE
LINEAR DIMENSIONS ARE IN: MILLIMETERS TOLERANCES: ANGLES= ±2° DEFAULT LINEAR TOLERANCES SEE TABLE DIM. & TOL. PER ASME Y14.5M-1994; DRW PER MIL-DTL-31000; OTHER AMPHENOL STANDARDS: 9-9318	MATERIAL SPEC.	APPROVALS DATE PREPARED BY: [Signature] ENGINEER IN CHARGE: [Signature] DESIGN MANAGER: [Signature] DESIGN ACTIVITY GROUP: [Signature] 2016-01-12 Amphenol Technology (ShenZhen) Co., Ltd. Building C, 2nd Industrial Zone of Xin Shi Jie, Jianshi Community, Gongming Sub-district, Guangming New District, Shenzhen, PRC UTX BULKHEAD CONNECTOR CUSTOMER DRAWING				
	PROCESS SPEC.	THIRD ANGLE PROJECTION 				
LEGENDS: △=FLAG NOTE CALL OUT REFERENCE ONLY	N/A	SIZE	CAGE CODE	DOCUMENT NO.		
		C	/	UTX()		B
		SCALE: 1:0	REF.			SHEET 1 OF 4

UTX BULKHEAD M14

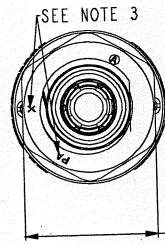

WRENCH TOOL: H4TM1400
SIZE: 18.9 ± 0.3mm

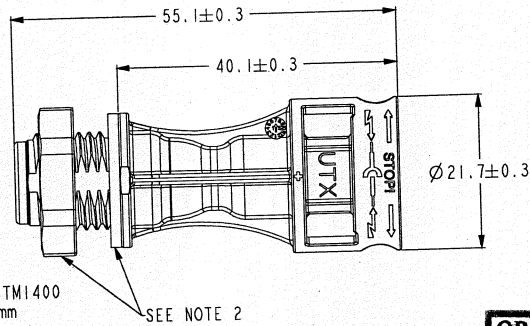

MALE END

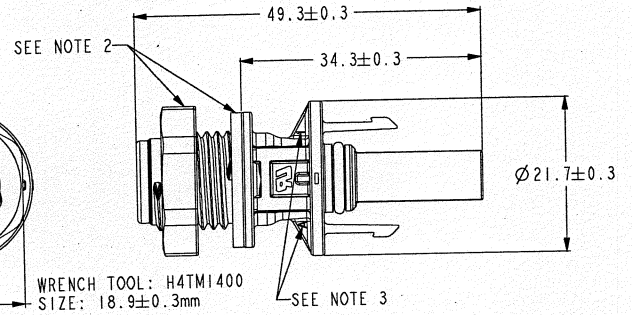
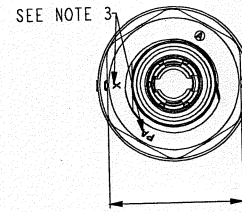

FEMALE END

ORIGINAL COPY (正宗原版)
1 2 JAN 2016
DOCUMENT CONTROL

UTX BULKHEAD M12

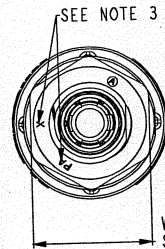

WRENCH TOOL: H4TM1200
SIZE: 17.0 ± 0.3mm

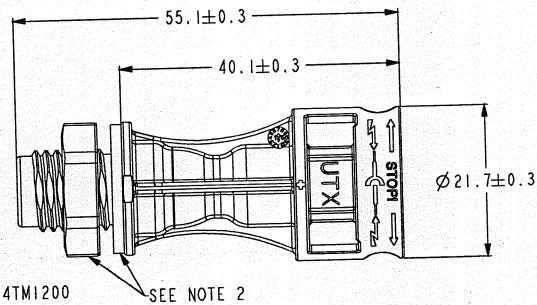

MALE END

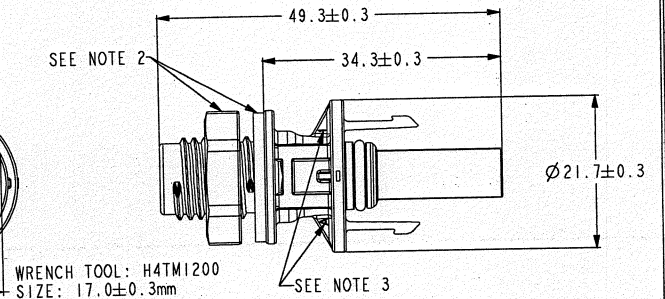
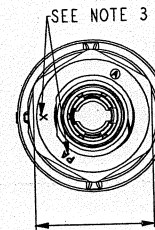

FEMALE END

3. THE MARK OF LETTERS JUST THE VERSION CAVITY NUMBER AND MATERIAL MARK OF THE PLASTIC PARTS FOR AMPHENOL'S MANUFACTURE PROCEDURE, WHEN THE CUSTOMER INSPECT THE PRODUCT, THEY CAN IGNORE THESE NUMBERS.

NOTES:

2. FLAT GASKET SHOULD BE ASSEMBLED TO THE BODY; THE NUT SHOULD BE NOT ASSEMBLED TO THE BODY.

THIS DOCUMENT CONTAINS PROPRIETARY INFORMATION AND SUCH INFORMATION MAY NOT BE DISCLOSED TO OTHERS FOR ANY PURPOSE OR USED FOR MANUFACTURING PURPOSES WITHOUT WRITTEN PERMISSION FROM THE AMPHENOL CORP.

SIZE C	CAGE CODE /	DOCUMENT NO. UTX()	REV. B
SCALE: 1.0		REF:	SHEET 2 OF 4

STAMPING FORMING CONTACT

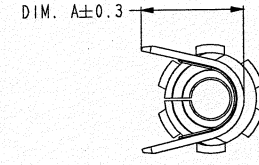
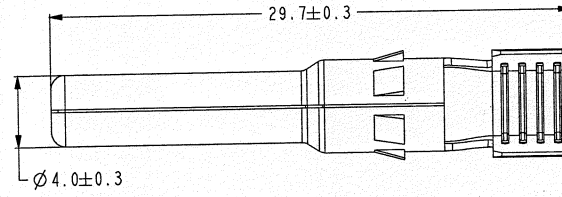
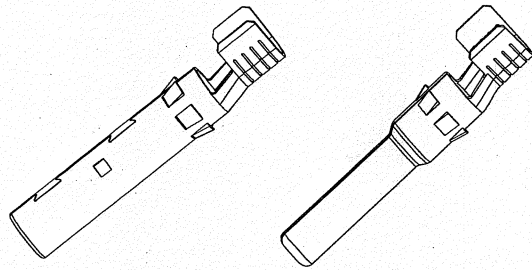

PIN

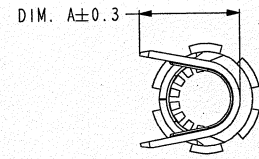
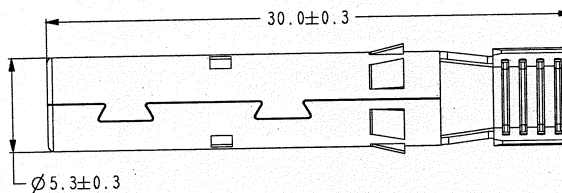

SOCKET

CABLE SIZE	A (mm)
2.5mm ²	4.8
4.0 & 6.0mm ²	5.8

ORIGINAL COPY (正宗原稿)
1 2 JAN 2016
DOCUMENT CONTROL

COLD FORMING CONTACT

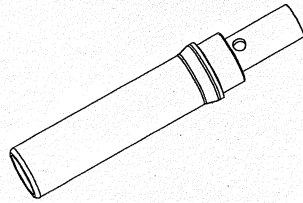

2.5mm²(14 AWG) PROFILE SHOW

ACCEPT WIRE CONDUCTOR SIZE mm ² (AWG)	"A"	"B"
2.5 (14)	2.30	3.50
4.0 (12)	3.05	4.60
6.0 (10)	3.75	5.25

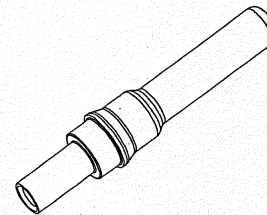

2.5mm²(14 AWG) PROFILE SHOW

ACCEPT WIRE CONDUCTOR SIZE mm ² (AWG)	"C"	"D"
2.5 (14)	2.30	3.50
4.0 (12)	3.05	4.60
6.0 (10)	3.75	5.25

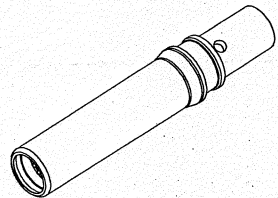

4mm²(12 AWG); 6mm²(10 AWG) PROFILE SHOW

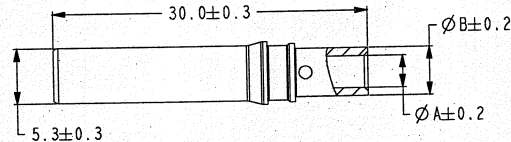

SOCKET

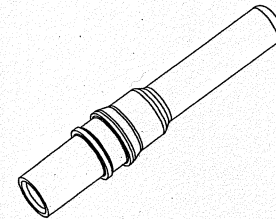

4mm²(12 AWG); 6mm²(10 AWG) PROFILE SHOW

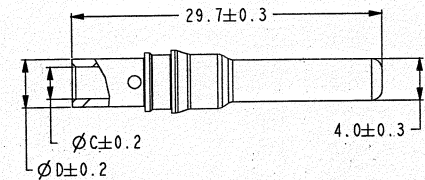

PIN

NOTES:

THIS DOCUMENT CONTAINS PROPRIETARY INFORMATION AND SUCH INFORMATION MAY NOT BE DISCLOSED TO OTHERS FOR ANY PURPOSE OR USED FOR MANUFACTURING PURPOSES WITHOUT WRITTEN PERMISSION FROM THE AMPHENOL CORP.

PANEL SPECIFICATOIN

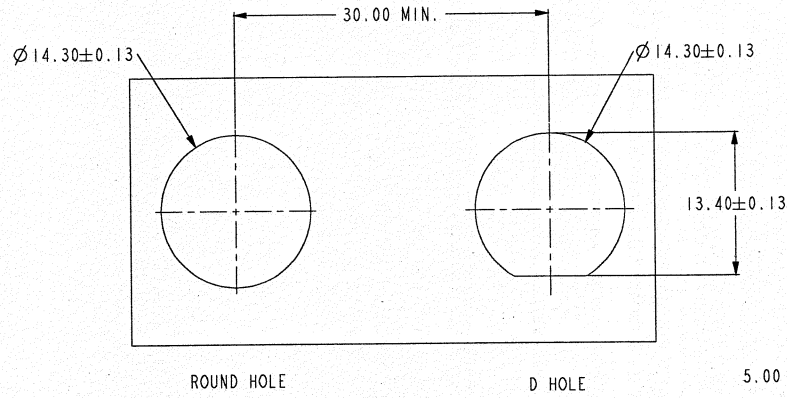

UTX BULKHEAD M14

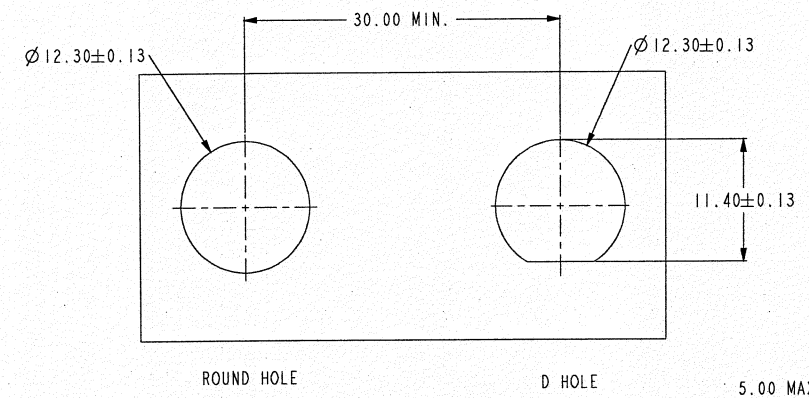

UTX BULKHEAD M12

ORDER P/N IN SYSTEM

C/N: UTX N F A 2 A M

- I: 1PCS/BAG, 800PCS/BOX
- C: 100PCS/BAG, 8BAGS/BOX
- M: 400PCS/BAG, 2BAGS/BAX

- TUV/UL CERTIFIED
- 0: NO CONTACTS
- 2: 2.5mm²/14AWG (FOR C&F AND S&F CONTACT)
- 4: 486mm²/12&10AWG (FOR S&F CONTACT)
4mm²/12 AWG (FOR C&F CONTACT)
- 6: 6mm²/10 AWG (FOR C&F CONTACT)

- A: STAMPING FORMING CONTACT
- B: COLD FORMING CONTACT

- F: FEMALE CONNECTOR
- M: MALE CONNECTOR

- M: BULKHEAD M12
- N: BULKHEAD M14

ORIGINAL COPY (正宗原版)
 1 2 JAN 2016
DOCUMENT CONTROL

NOTES:

THIS DOCUMENT CONTAINS PROPRIETARY INFORMATION AND SUCH INFORMATION MAY NOT BE DISCLOSED TO OTHERS FOR ANY PURPOSE OR USED FOR MANUFACTURING PURPOSES WITHOUT WRITTEN PERMISSION FROM THE AMPHENOL CORP.

SIZE C	CAGE CODE /	DOCUMENT NO. UTX()	REV. B
SCALE: 1.0		REF:	SHEET 4 OF 4

单击下面可查看定价，库存，交付和生命周期等信息

[>>Amphenol\(安费诺\)](#)