



RF360
Europe GmbH

Data sheet

BAW filter

WLAN 2G; Bluetooth

Part number:	B4346
Ordering code:	B39242B4346P810
Date:	April 01, 2021
Version:	2.2

DCN: 80-PA243-558 Rev. A

Qualcomm products mentioned herein are products of Qualcomm Technologies, Inc. and/or its subsidiaries.

RF360 Europe GmbH
Anzinger Straße 13
81671 Munich, Germany

© 2021 Qualcomm Technologies, Inc. and/or its subsidiaries. All rights reserved

These materials, including the information contained herein, may be used only for informational purposes by the customer. Qualcomm Technologies, Inc. and/or its subsidiaries assume no responsibility for errors or omissions in these materials or the information contained herein and reserve the right to make changes to the product(s) or information contained herein without notice. The materials and information are provided on an AS IS basis, without warranty, either expressed or implied, with respect to the materials, or any output or results based on the use, application, or evaluation of such materials, including without limitation, with respect to the non-infringement of trademarks, patents, copyrights or any other intellectual property rights or other rights of third parties.

No use of this documentation or any information contained herein grants any license, whether express, implied, by estoppel or otherwise, to any intellectual property rights, including, without limitation, to any patents owned by QUALCOMM Incorporated or any of its subsidiaries.

Not to be used, copied, reproduced, or modified in whole or in part, nor its contents revealed in any manner to others without the express written permission of RF360 Europe GmbH.

Qualcomm is a trademark or registered trademark of Qualcomm Incorporated. Other product and brand names may be trademarks or registered trademarks of their respective owners.

This technical data may be subject to U.S. and international export, re-export, or transfer ("export") laws. Diversion contrary to U.S. and international law is strictly prohibited.

Table of contents

1 Application	4
2 Features	4
3 Package	5
4 Pin configuration	5
5 Matching circuit	6
6 Characteristics	7
7 Maximum ratings	8
8 Transmission coefficient	9
9 Transmission coefficient (WLAN)	10
10 Transmission coefficient (BT)	11
11 Transmission coefficient (integrated)	12
12 Reflection coefficients	13
13 Packing material	14
14 Marking	17
15 Soldering profile	18
16 Annotations	19
17 Cautions and warnings	20
18 Important notes	21

1 Application

- Low-loss BAW RF single filter for Bluetooth/WLAN 2G with LTE Band 7 / Band 40 / Band 41 coexistence for Automotive telematics
- WLAN 2G; Bluetooth: pass band 2401.5 – 2480.9 MHz
- Usable pass band 79.4 MHz
- Excellent insertion loss
- High out of band selectivity
- Filter impedance 50 Ω
- Excellent B7 attenuation

2 Features

- Package size 1.4±0.1 mm × 1.1±0.1 mm
- Package height 0.45 mm (max.)
- Approximate weight 2 mg
- RoHS compatible
- Package for Surface Mount Technology (SMT)
- Ni/Au-plated terminals
- Filter surface passivated
- Electrostatic Sensitive Device (ESD)
- Moisture Sensitivity Level 2a (MSL2a)
- AEC-Q200 qualified component family (Grade 3: -40 °C to +85 °C)

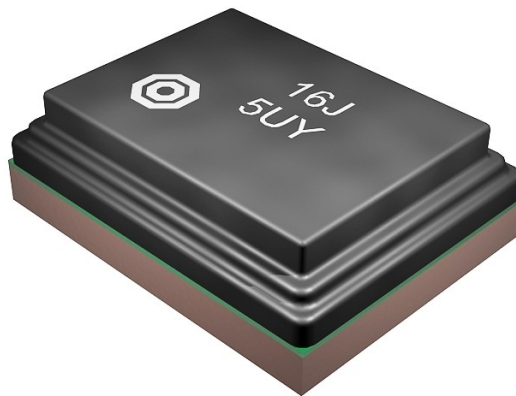
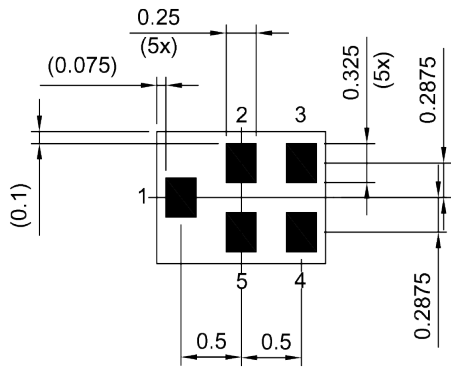

Figure 1: Picture of component with example of product marking.

3 Package

BOTTOM VIEW



Pad and pitch tolerance ±0.05

4 Pin configuration

- 1 Input
- 4 Output
- 2, 3, 5 Ground

SIDE VIEW

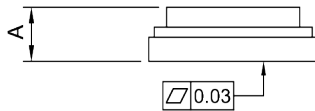

TOP VIEW

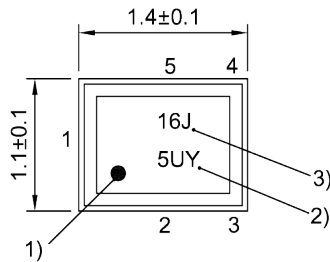

- 1) Marking for pad number 1
- 2) Example of encoded lot number
- 3) Example of encoded filter type number

Land pattern
THRU VIEW

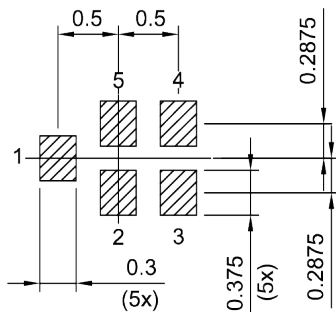

Landing pad tolerance -0.02

Figure 2: Drawing of package with package height A = 0.45 mm (max.). See Sec. Package information (p. 20).

5 Matching circuit

■ $L_{p1} = 10 \text{ nH}$

■ $L_{s4} = 1.2 \text{ nH}$

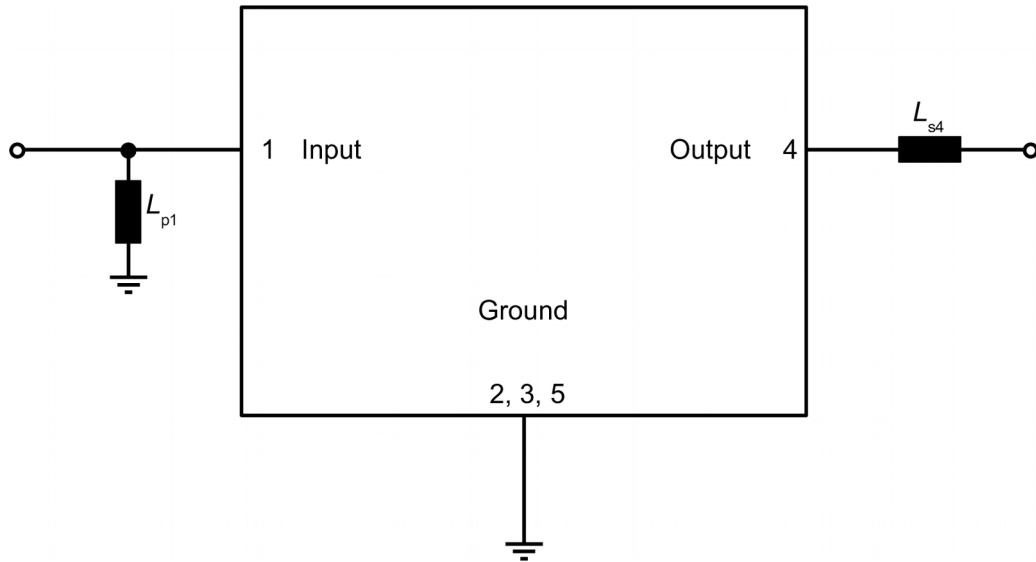

Figure 3: Schematic of matching circuit.

6 Characteristics

Temperature range for specification	T_{SPEC}	= -40 °C ... +85 °C
Input terminating impedance	Z_{IN}	= 50 Ω // 10 nH ¹⁾
Output terminating impedance	Z_{OUT}	= 50 Ω + 1.2 nH ¹⁾

Characteristics				min. for T_{SPEC}	typ. @ +25 °C	max. for T_{SPEC}		
Center frequency				f_C	—	2442	—	MHz
Insertion attenuation – WLAN				$\alpha_{WLAN}^{2)}$				
WLAN Channel 1	2403.1... 2420.9	MHz		—	1.9	2.7		dB
WLAN Channel 2	2408.1... 2425.9	MHz		—	1.7	2.2		dB
WLAN Channel 3-11	2413.1... 2470.9	MHz		—	1.4	2.0		dB
WLAN Channel 12	2458.1... 2475.9	MHz		—	1.6	2.2		dB
WLAN Channel 13	2463.1... 2480.9	MHz		—	1.8	2.7		dB
Insertion attenuation – BT				$\alpha_{BT}^{3)}$				
Bluetooth	2401.5... 2480.5	MHz		—	1.5	2.0		dB
VSWR								
@ input port								
	2403.1... 2475.9	MHz		—	1.6	2.3		
	2463.1... 2480.9	MHz		—	1.8	2.5		
@ output port								
	2403.1... 2475.9	MHz		—	1.6	2.3		
	2463.1... 2480.9	MHz		—	1.8	2.3		
Attenuation								
	100... 1805	MHz	α	32	37	—		dB
	1805... 2170	MHz	α	33	38	—		dB
	2300... 2360	MHz	α	35	40	—		dB
	2360... 2365	MHz	$\alpha_{INT}^{4), 5)}$	38	42	—		dB
	2365... 2370	MHz	$\alpha_{INT}^{4), 5)}$	40	43	—		dB
	2370... 2375	MHz	$\alpha_{INT}^{4), 5)}$	35	45	—		dB
	2375... 2380	MHz	$\alpha_{INT}^{4), 5)}$	15	42	—		dB
	2500... 2505	MHz	$\alpha_{INT}^{4), 5)}$	43 ⁶⁾	62	—		dB
	2500... 2505	MHz	$\alpha_{INT}^{4), 5)}$	26 ⁷⁾	62	—		dB
	2505... 2570	MHz	α	43	52	—		dB
	2570... 2620	MHz	α	42	47	—		dB
	2620... 2690	MHz	α	40	47	—		dB
	4800... 5850	MHz	α	20	28	—		dB

1) See Sec. Matching circuit (p. 6).
 2) Average over each WLAN channel with band width of 17.8 MHz.
 3) Averaged value over whole pass band with band width of 79 MHz due to frequency hopping in Bluetooth mode.
 4) Integrated over 5 MHz.
 5) Averaged values of linear S-parameter over any 5MHz.
 6) Valid for temperature $T = +25\text{ °C} \dots +85\text{ °C}$.
 7) Valid for temperature $T = -40\text{ °C} \dots +25\text{ °C}$.

7 Maximum ratings

Operable temperature	$T_{OP} = -40\text{ °C} \dots +85\text{ °C}$	
Storage temperature	$T_{STG}^{1)} = -40\text{ °C} \dots +85\text{ °C}$	
DC voltage	$ V_{DC} ^{2)} = 0\text{ V (max.)}$	
Input power	P_{IN}	
@ input port: 2403.1 ... 2480.9 MHz	25 dBm	Continuous wave for 5000 h @ 85 °C. Source and load impedance 50Ω.
@ output port: 2403.1 ... 2480.9 MHz	22 dBm	Continuous wave for 5000 h @ 85 °C. Source and load impedance 50Ω.

¹⁾ Not valid for packaging material. Storage temperature for packaging material is -25 °C to +40 °C.

²⁾ In case of applied DC voltage blocking capacitors are mandatory.

8 Transmission coefficient

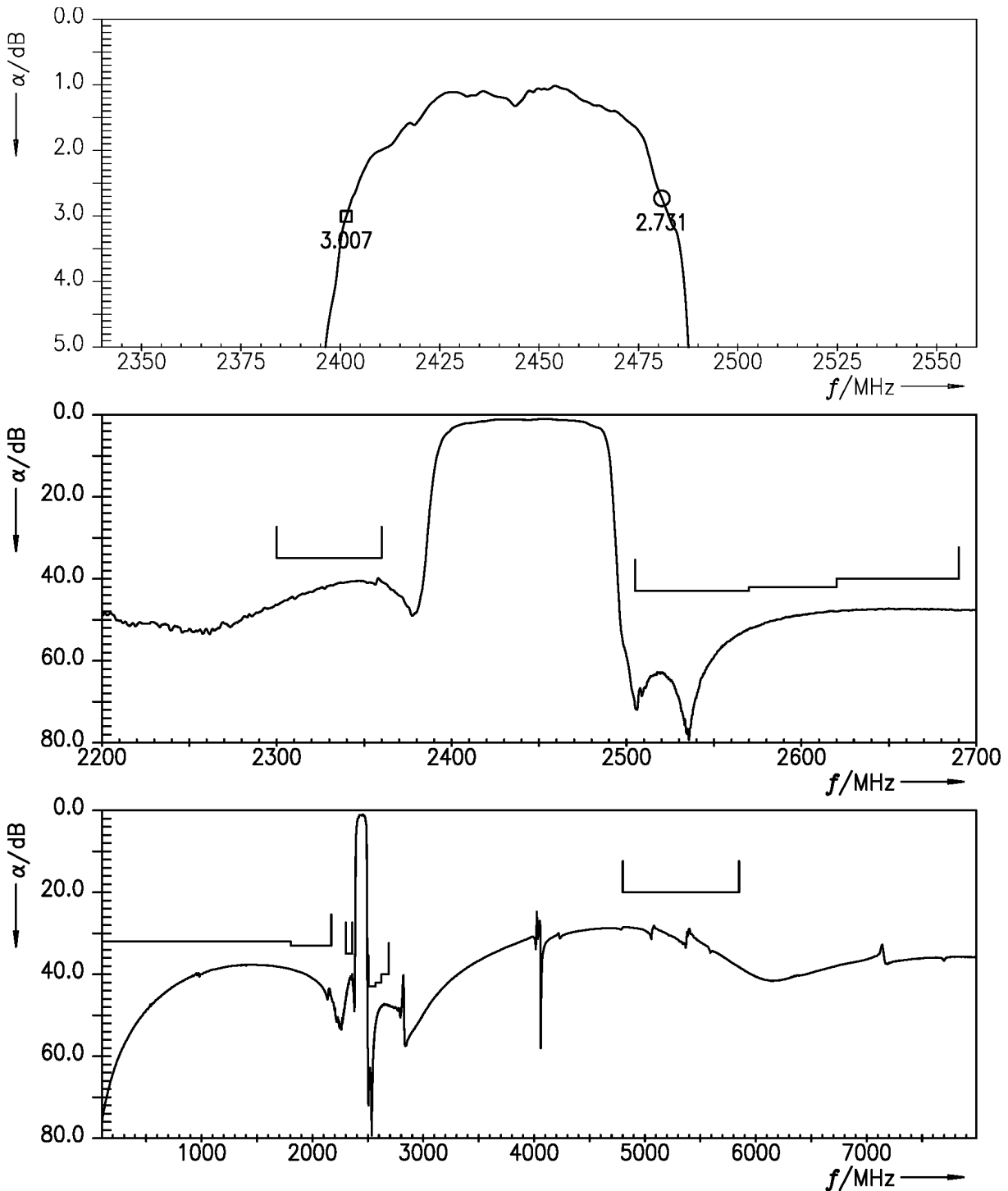

Figure 4: Attenuation.

9 Transmission coefficient (WLAN)

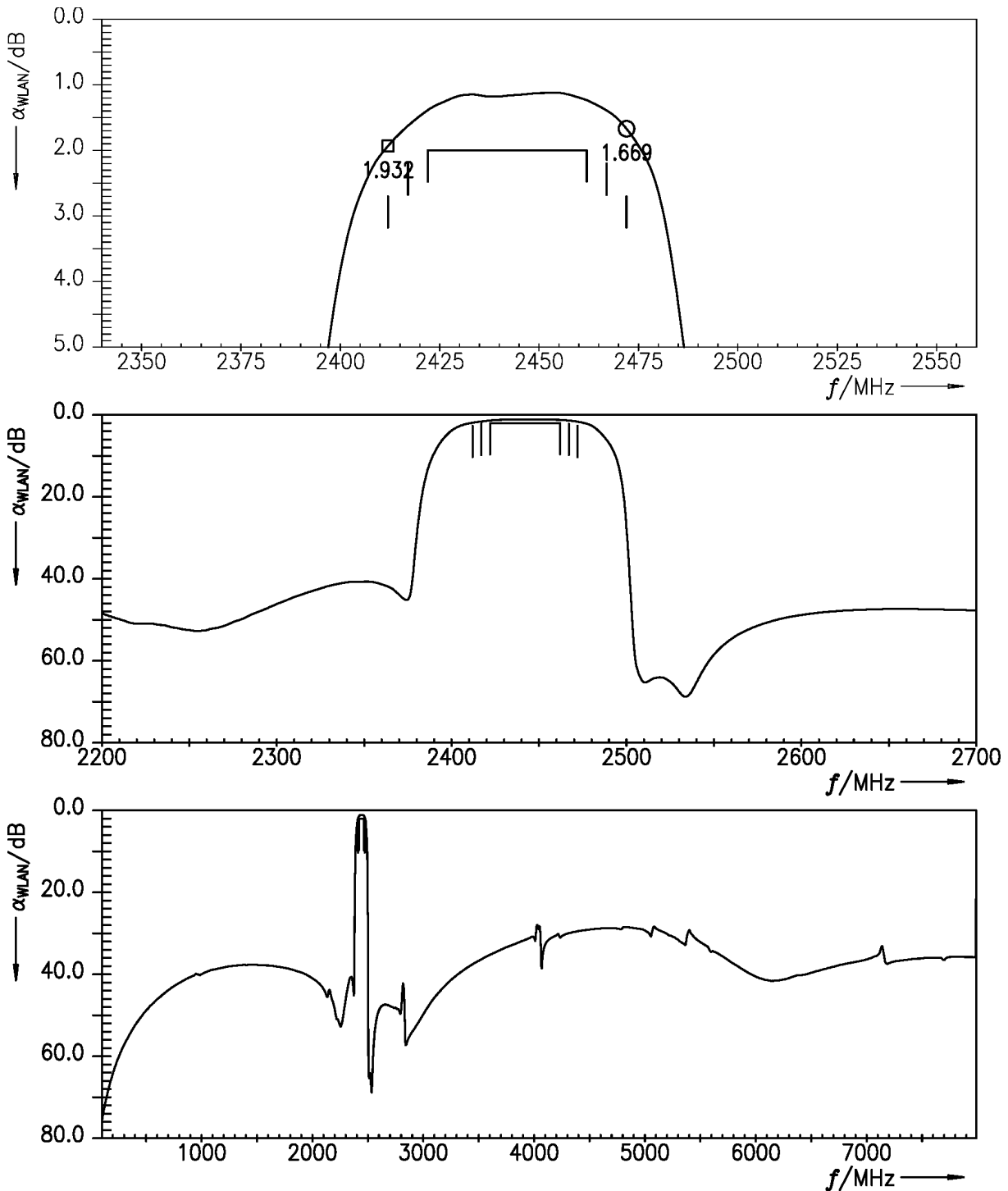

Figure 5: Attenuation (WLAN) (integration window = 17.8 MHz).

10 Transmission coefficient (BT)

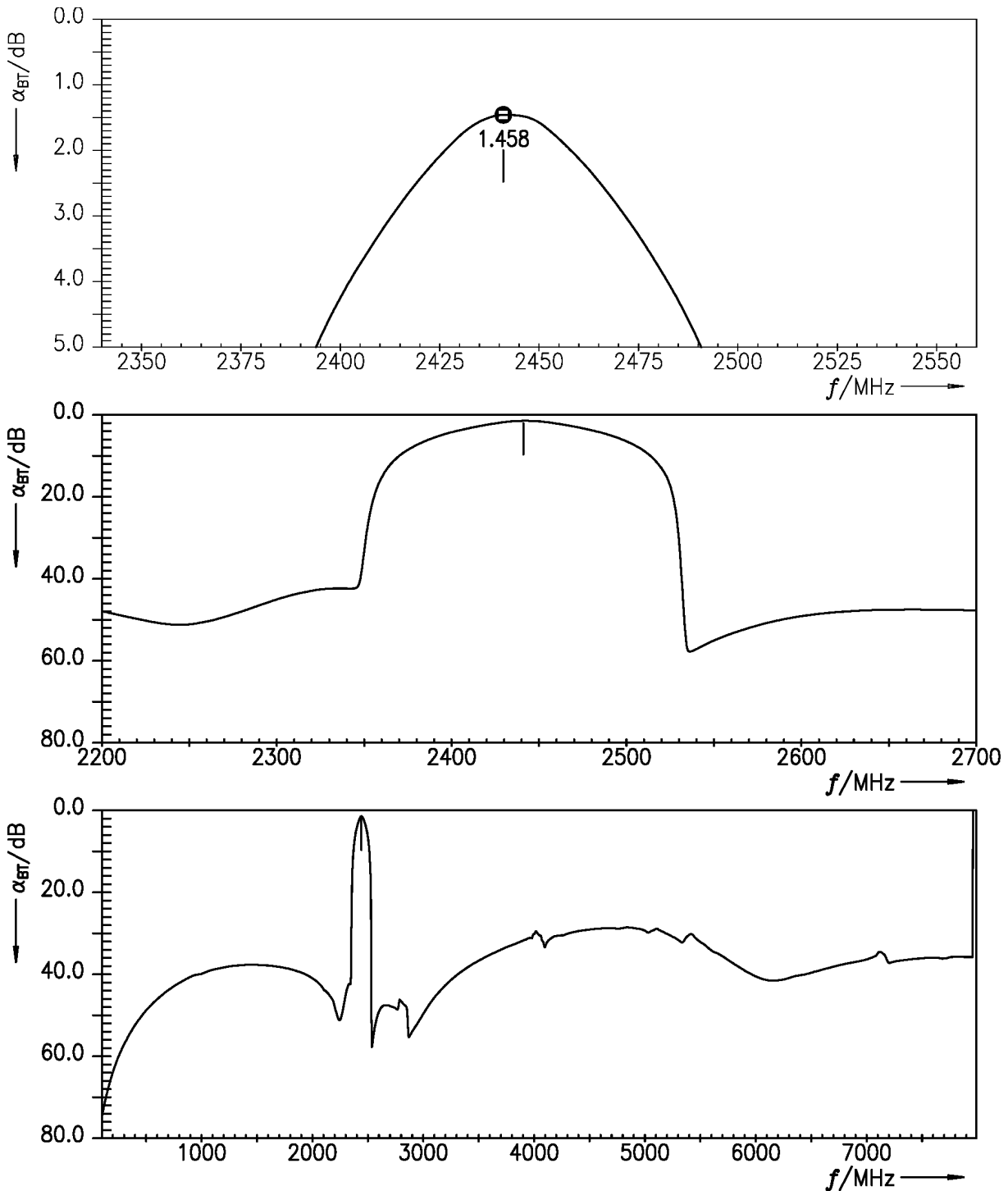

Figure 6: Attenuation (BT) (integration window = 79 MHz).

11 Transmission coefficient (integrated)

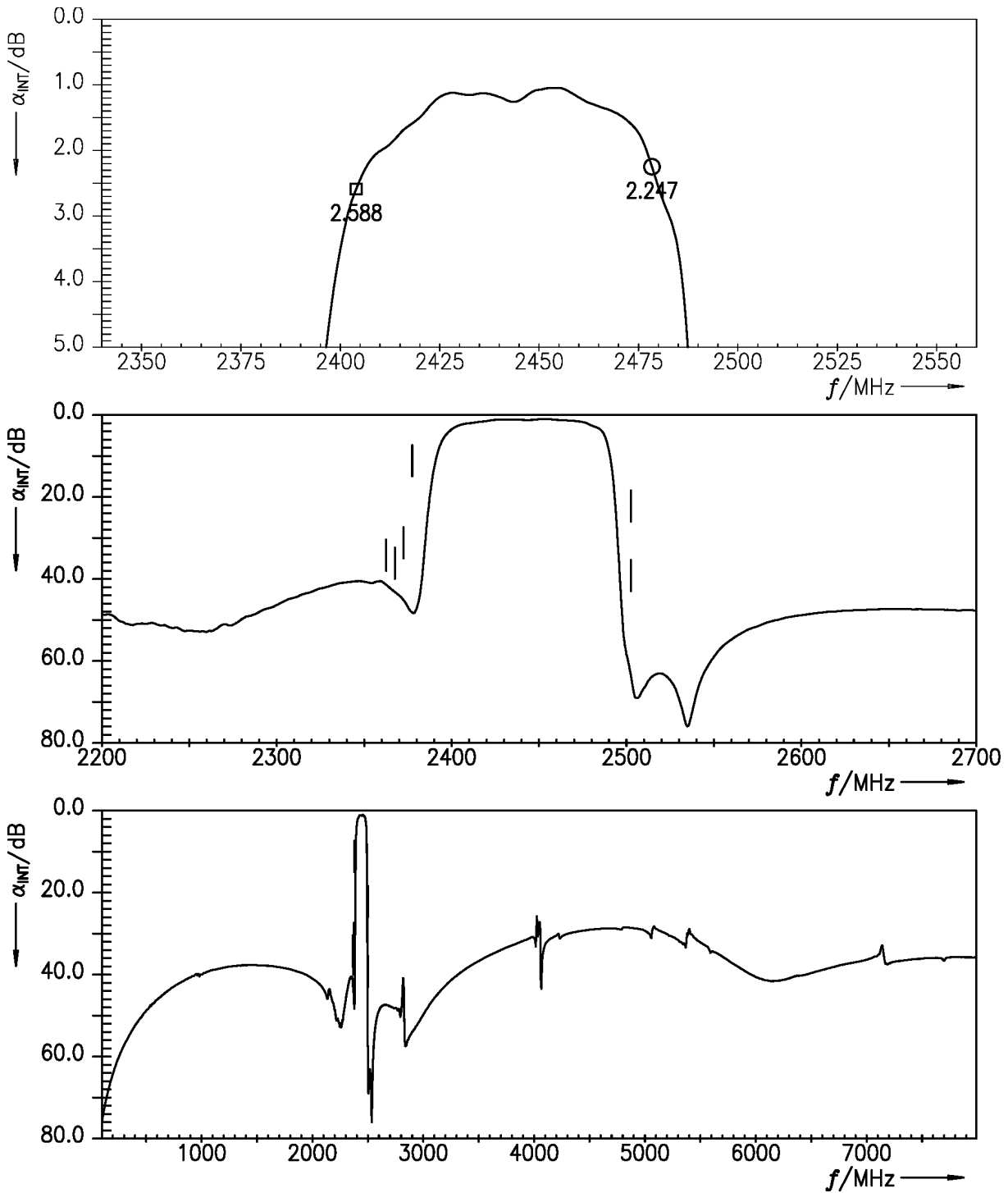

Figure 7: Integrated attenuation (integration window = 5 MHz).

12 Reflection coefficients

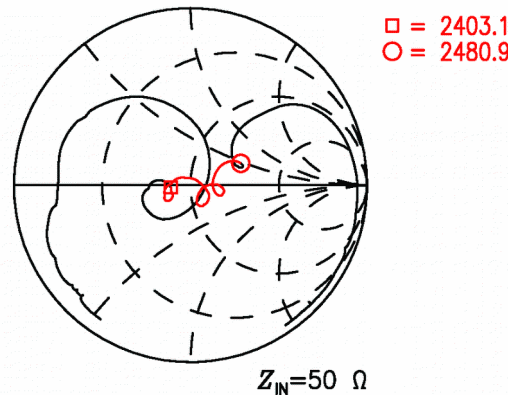
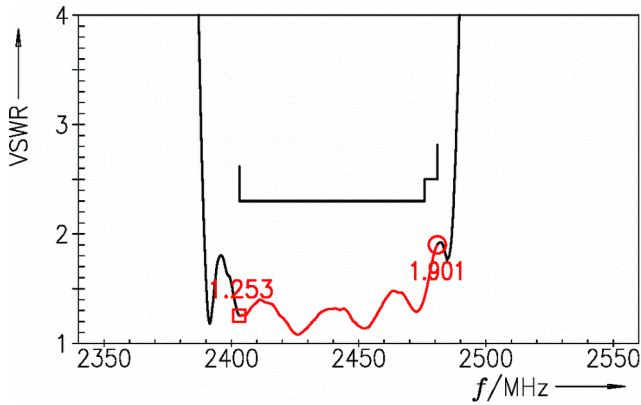

Figure 8: Reflection coefficient at input port.

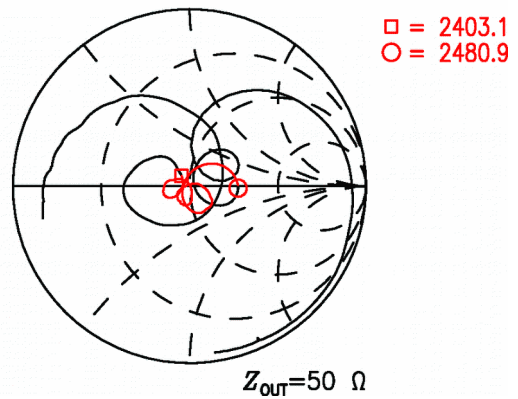
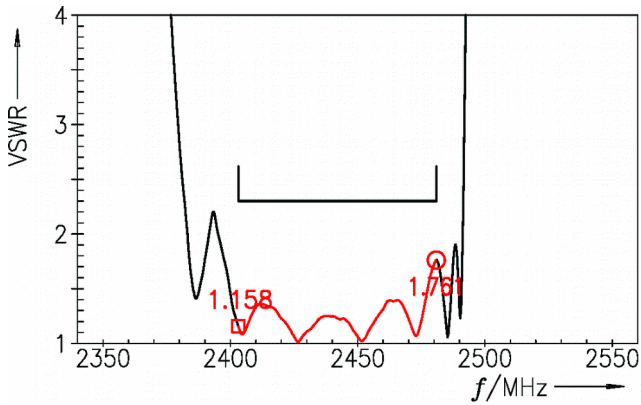

Figure 9: Reflection coefficient at output port.

13 Packing material

13.1 Tape

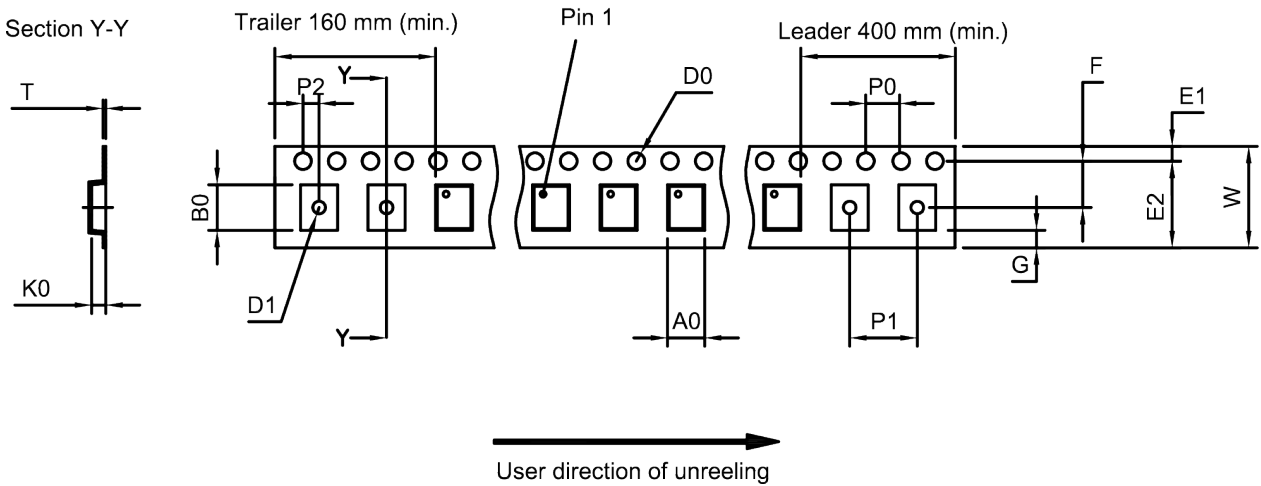

Figure 10: Drawing of tape (first-angle projection) for illustration only and not to scale. The valid tape dimensions are listed in Table 1.

A ₀	1.27±0.05 mm	E ₂	6.25 mm (min.)	P ₁	4.0±0.1 mm
B ₀	1.57±0.05 mm	F	3.5±0.05 mm	P ₂	2.0±0.05 mm
D ₀	1.5+0.1/-0 mm	G	0.75 mm (min.)	T	0.25±0.03 mm
D ₁	0.5±0.1 mm	K ₀	0.62±0.05 mm	W	8.0+0.3/-0.1 mm
E ₁	1.75±0.1 mm	P ₀	4.0±0.1 mm		

Table 1: Tape dimensions.

13.2 Reel with diameter of 180 mm

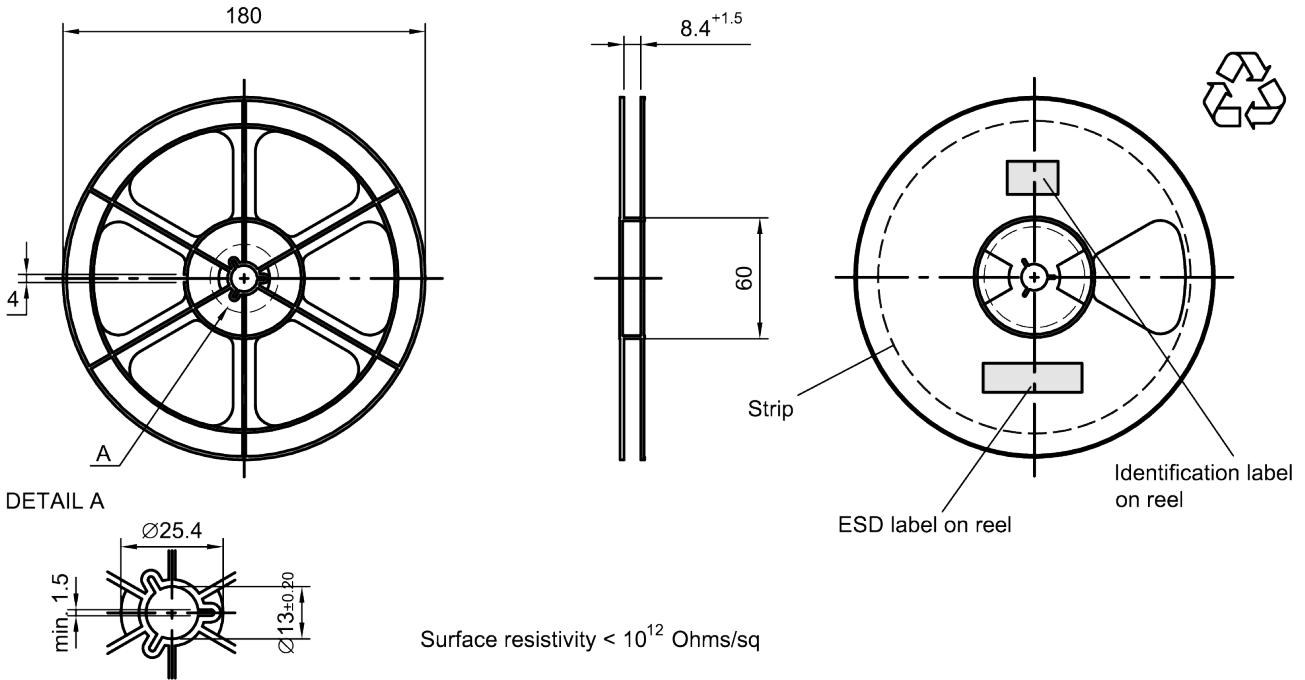

Figure 11: Drawing of reel (first-angle projection) with diameter of 180 mm.

Dimensions [mm]

X = 220+5

Y = 235+5

Sealing area 10±3

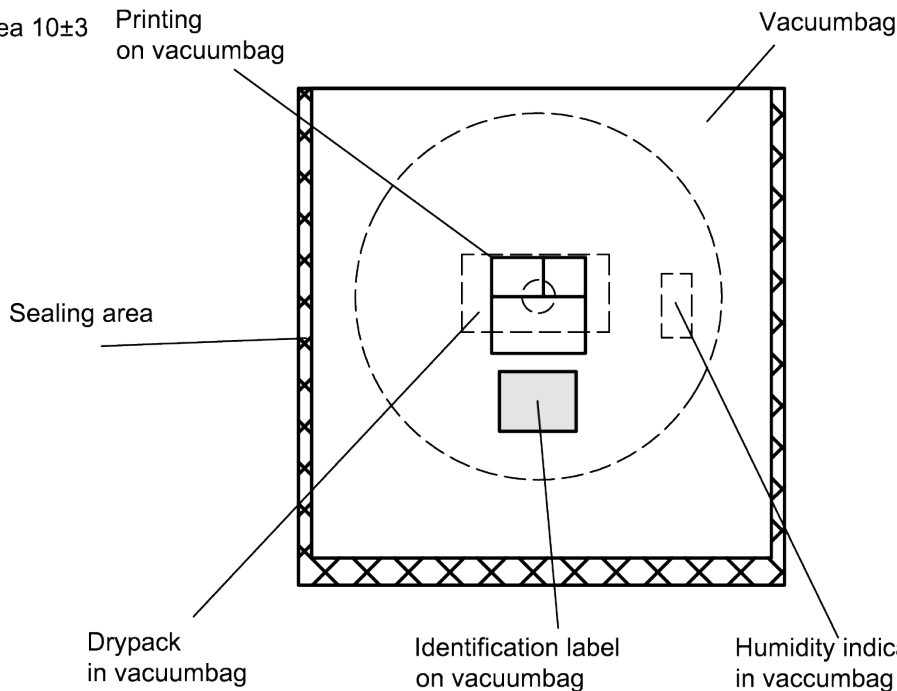

Figure 12: Drawing of moisture barrier bag (MBB) for reel with diameter of 180 mm.

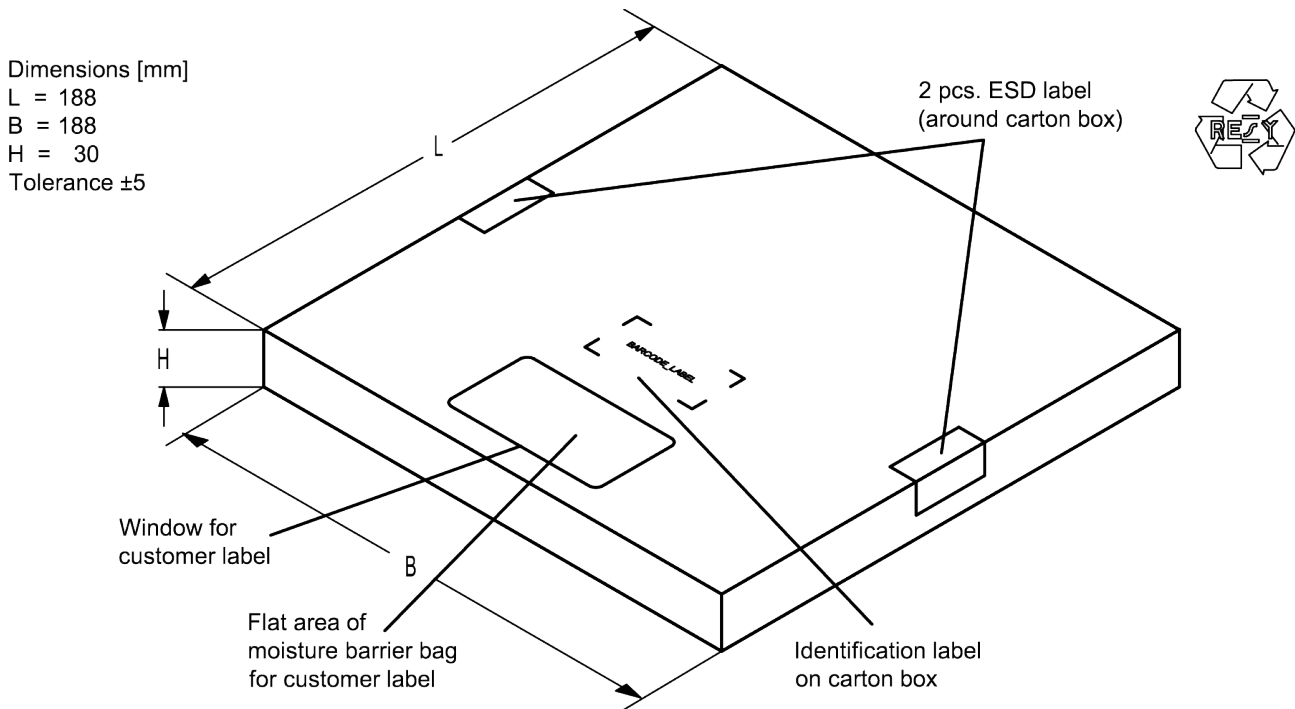

Figure 13: Drawing of folding box for reel with diameter of 180 mm.

14 Marking

Products are marked with product type number and lot number encoded according to Table 2:

■ Type number:

The 4 digit type number of the ordering code, e.g., B3xxxxB**1234**xxxx,
is encoded by a special BASE32 code into a 3 digit marking.

Example of decoding type number marking on device in decimal code.
16J => **1234**
 $1 \times 32^2 + 6 \times 32^1 + 18 (=J) \times 32^0 =$ **1234**
 The BASE32 code for product type B4346 is 47T.

■ Lot number:

The last 5 digits of the lot number, e.g., **12345**,
are encoded based on a special BASE47 code into a 3 digit marking.

Example of decoding lot number marking on device in decimal code.
5UY => **12345**
 $5 \times 47^2 + 27 (=U) \times 47^1 + 31 (=Y) \times 47^0 =$ **12345**

Adopted BASE32 code for type number			
Decimal value	Base32 code	Decimal value	Base32 code
0	0	16	G
1	1	17	H
2	2	18	J
3	3	19	K
4	4	20	M
5	5	21	N
6	6	22	P
7	7	23	Q
8	8	24	R
9	9	25	S
10	A	26	T
11	B	27	V
12	C	28	W
13	D	29	X
14	E	30	Y
15	F	31	Z

Adopted BASE47 code for lot number			
Decimal value	Base47 code	Decimal value	Base47 code
0	0	24	R
1	1	25	S
2	2	26	T
3	3	27	U
4	4	28	V
5	5	29	W
6	6	30	X
7	7	31	Y
8	8	32	Z
9	9	33	b
10	A	34	d
11	B	35	f
12	C	36	h
13	D	37	n
14	E	38	r
15	F	39	t
16	G	40	v
17	H	41	\
18	J	42	?
19	K	43	{
20	L	44	}
21	M	45	<
22	N	46	>
23	P		

Table 2: Lists for encoding and decoding of marking.

15 Soldering profile

The recommended soldering process is in accordance with IEC 60068-2-58 – 3rd edit and IPC/JEDEC J-STD-020B.

ramp rate	≤ 3 K/s
preheat	125 °C to 220 °C, 150 s to 210 s, 0.4 K/s to 1.0 K/s
T > 220 °C	30 s to 70 s
T > 230 °C	min. 10 s
T > 245 °C	max. 20 s
T ≥ 255 °C	–
peak temperature T_{peak}	250 °C +0/-5 °C
wetting temperature T_{min}	230 °C +5/-0 °C for 10 s ± 1 s
cooling rate	≤ 3 K/s
soldering temperature T	measured at solder pads

Table 3: Characteristics of recommended soldering profile for lead-free solder (Sn95.5Ag3.8Cu0.7).

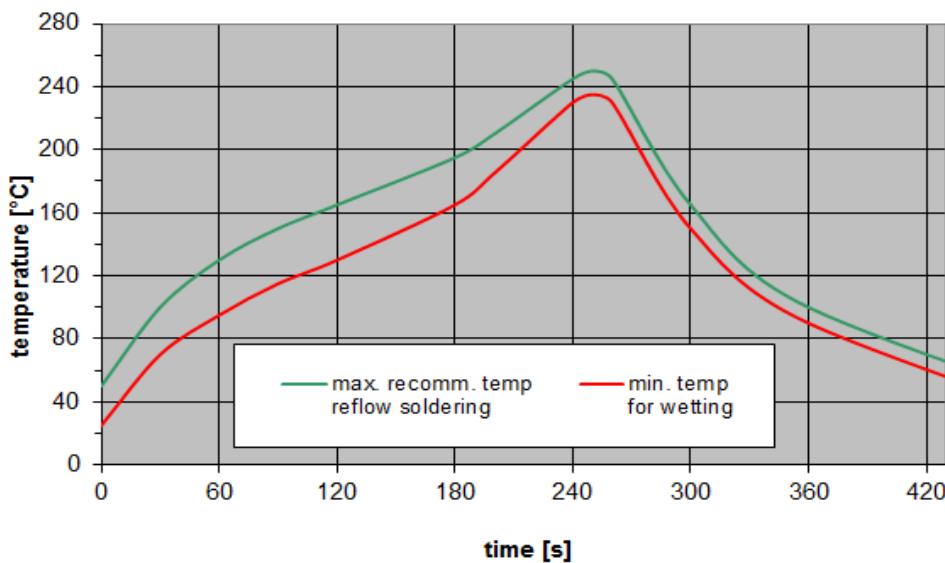

Figure 14: Recommended reflow profile for convection and infrared soldering – lead-free solder.

16 Annotations

16.1 RoHS compatibility

ROHS-compatible means that products are compatible with the requirements according to Art. 4 (substance restrictions) of Directive 2011/65/EU of the European Parliament and of the Council of June 8th, 2011, on the restriction of the use of certain hazardous substances in electrical and electronic equipment ("Directive") with due regard to the application of exemptions as per Annex III of the Directive in certain cases.

16.2 Scattering parameters (S-parameters)

The pin/port assignment is available in the headers of the S-parameter files. Please contact your local RF360 sales office.

17 Cautions and warnings

17.1 Display of ordering codes for RF360 products

The ordering code for one and the same product can be represented differently in data sheets, data books, other publications and the website of RF360, or in order-related documents such as shipping notes, order confirmations and product labels. The varying representations of the ordering codes are due to different processes employed and do not affect the specifications of the respective products. Detailed information can be found on the Internet under <https://rfe.qualcomm.com/>.

17.2 Material information

Due to technical requirements components may contain dangerous substances. For information on the type in question please also contact one of our sales offices.

For information on recycling of tapes and reels please contact one of our sales offices.

17.3 Moldability

Before using in overmolding environment, please contact your local RF360 sales office.

17.4 Package information

Landing area

The printed circuit board (PCB) land pattern (landing area) shown is based on RF360 internal development and empirical data and illustrated for example purposes, only. As customers' SMD assembly processes may have a plenty of variants and influence factors which are not under control or knowledge of RF360, additional careful process development on customer side is necessary and strongly recommended in order to achieve best soldering results tailored to the particular customer needs.

Dimensions

Unless otherwise specified all dimensions are understood using unit millimeter (mm).

Dimensions do not include burrs.

Projection method

Unless otherwise specified first-angle projection is applied.

18 Important notes

The following applies to all products named in this publication:

1. Some parts of this publication contain **statements about the suitability of our products for certain areas of application**. These statements are based on our knowledge of typical requirements that are often placed on our products in the areas of application concerned. We nevertheless expressly point out **that such statements cannot be regarded as binding statements about the suitability of our products for a particular customer application**. As a rule, RF360 Europe GmbH and its affiliates are either unfamiliar with individual customer applications or less familiar with them than the customers themselves. For these reasons, it is always ultimately incumbent on the customer to check and decide whether an RF360 product with the properties described in the product specification is suitable for use in a particular customer application.
2. We also point out that **in individual cases, a malfunction of electronic components or failure before the end of their usual service life cannot be completely ruled out in the current state of the art, even if they are operated as specified**. In customer applications requiring a very high level of operational safety and especially in customer applications in which the malfunction or failure of an electronic component could endanger human life or health (e.g. in accident prevention or life-saving systems), it must therefore be ensured by means of suitable design of the customer application or other action taken by the customer (e.g. installation of protective circuitry or redundancy) that no injury or damage is sustained by third parties in the event of malfunction or failure of an electronic component.
3. **The warnings, cautions and product-specific notes must be observed.**
4. In order to satisfy certain technical requirements, **some of the products described in this publication may contain substances subject to restrictions in certain jurisdictions (e.g. because they are classed as hazardous)**. Useful information on this will be found in our Material Data Sheets on the Internet (<https://rfe.qualcomm.com>). Should you have any more detailed questions, please contact our sales offices.
5. We constantly strive to improve our products. Consequently, **the products described in this publication may change from time to time**. The same is true of the corresponding product specifications. Please check therefore to what extent product descriptions and specifications contained in this publication are still applicable before or when you place an order. We also **reserve the right to discontinue production and delivery of products**. Consequently, we cannot guarantee that all products named in this publication will always be available.
The aforementioned does not apply in the case of individual agreements deviating from the foregoing for customer-specific products.

单击下面可查看定价，库存，交付和生命周期等信息

[>>Qualcomm-RF360](#)